

# OptoFILM™

## Solid State Switches

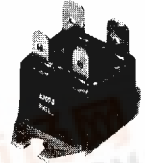
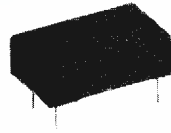

Engineering Specifications	OF(*) 1202	OF(*) 2402	OF(*) 1205D	OF(*) 2405D	OF(*) 1205-(X)	OF(*) 2405-(X)	OF(*) 1210-(X)	OF(*) 2410-(X)
<b>Output Characteristics</b>								
<b>Peak Blocking (V)</b>	400	500	400	500	400	500	400	500
<b>Output Rating (A/V<sub>RMS</sub>)</b>	1.5/120	1.5/240	3/120	3/240	5/120	5/240	10/120	10/240
<b>Max Off-State Leakage Current at Full Rated Load Voltage (mA)</b>	1.0	1.0	1.0	1.0	1.0	1.0	1.0	1.0
<b>Max On-State Voltage Drop (V<sub>RMS</sub>)<sup>1</sup></b>	1.4	1.4	1.7	1.7	1.7	1.7	1.7	1.7
<b>Min Critical Rate of Rise Voltage dv/dt (V/μsec)</b>	200	200	200	200	200	200	200	200
<b>Max Holding Current (mA)</b>	1.0	1.0	1.0	1.0	1.0	1.0	1.0	1.0
<b>Max Turn-on, Turn-Off Time (cycle)</b>	1/2	1/2	1/2	1/2	1/2	1/2	1/2	1/2
<b>Max Zero-Cross Turn-On Voltage (VAC [peak])</b>								
1st 1/2 Cycle	10	10	10	10	10	10	10	10
Sub. 1/2 Cycle	5	5	5	5	5	5	5	5
<b>Operating Frequency (Hz)</b>								
Minimum	20	20	20	20	20	20	20	20
Maximum	500	500	500	500	500	500	500	500
<b>Min Load Power Factor for Guaranteed Turn-On<sup>2</sup></b>	0.75	0.75	0.75	0.75	0.75	0.75	0.75	0.75
<b>Input Characteristics</b>								
<b>Control Voltage (DC)</b>								
Minimum (OFA)	4	4	4	4	4	4	4	4
(OFB)	9	9	9	9	9	9	9	9
(OFC)	20	20	20	20	20	20	20	20
Typical (OFA)	5	5	5	5	5	5	5	5
(OFB)	12	12	12	12	12	12	12	12
(OFC)	24	24	24	24	24	24	24	24
Maximum (OFA)	8	8	8	8	8	8	8	8
(OFB)	16	16	16	16	16	16	16	16
(OFC)	26	26	26	26	26	26	26	26
<b>Max Control Current to Operate (mA)</b>	16	16	16	16	16	16	16	16
<b>Min Dropout Voltage (VDC)</b>	2	2	2	2	2	2	2	2

<sup>1</sup>VRMS '02 Series at 1.5A rms, T<sub>J</sub> = 115°C; VRMS '05 Series at 5A rms, T<sub>J</sub> = 115°C; VRMS '10 Series at 10A rms, T<sub>J</sub> = 115°C.

<sup>2</sup>Operation at lower power factors can be achieved with 100 ohm/.01 ufd snubber across relay output terminals.

- (\*) "A" designates 4-8VDC Control
- "B" designates 9-16VDC Control
- "C" designates 20-26VDC Control

- (X) "1" specifies 0.3" pins
- "2" specifies Quick Connect
- "3" specifies 0.175" pins

High voltage option available (H Suffix)

**Features:**

- Ratings to 600V, 10A
- UL recognized
- Zero-crossing detection
- DC control, AC output
- Optically isolated
- TTL and CMOS compatible
- Low EMI and RFI generation
- CSA, VDE compatible

**Absolute Maximum Ratings**

Parameter	Min	Max	Units
Isolation Voltage:			
Input-to-Output	4000	—	V <sub>RMS</sub>
Terminals-to-Tab/Case	4000	—	V <sub>RMS</sub>
Thermal Resistance:			
Junction-to-Ambient	—	41.0	°C/Watt <sup>1</sup>
Junction-to-Tab	—	5.9	°C/Watt <sup>2</sup>
Input to Output Capacitance	—	4	pF
Continuous Control Current	—	100	mA
Peak Control Current (100 μsec)	—	1	A
Peak Output Current (one cycle)	—	25	A
Reverse Control Voltage	—	5	VDC
Operating Temperature	-25	85	°C
Storage Temperature	-25	150	°C
Soldering Temperature (10 seconds on leads)	—	260	°C

<sup>1</sup>'02 Series T<sub>A</sub> = 40°C

<sup>2</sup>'05, '10 Series T<sub>TAB</sub> = 65°C

All characteristics at 25°C



# OptoFILM™

## Operating Specifications

### Mechanical Dimensions

All dimensions are measured in millimeters (inches).

#### 1.5A Series

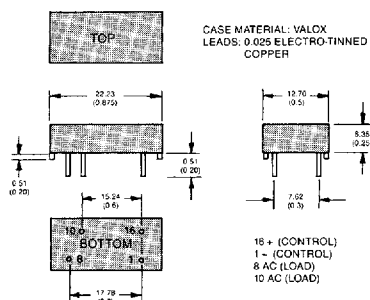

#### 3A Series

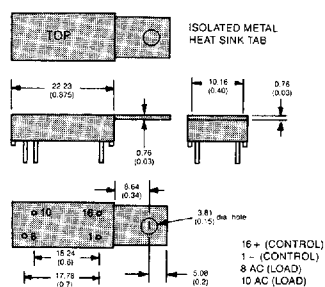

#### 5 & 10A Series, Quick Connect

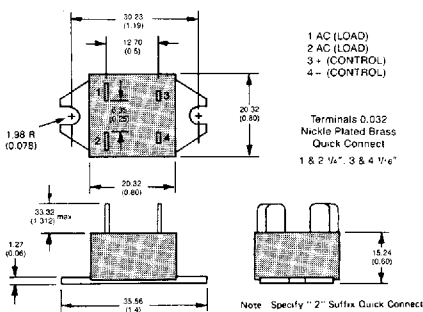

#### 5 & 10A Series, Pins

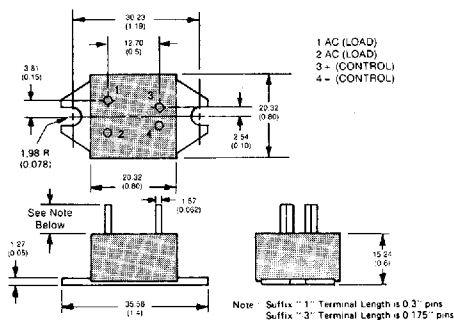

### Equivalent Circuit

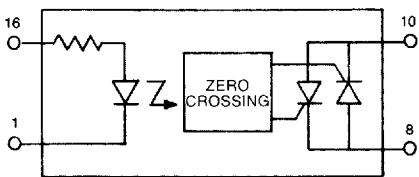

### Load Current vs. Temperature

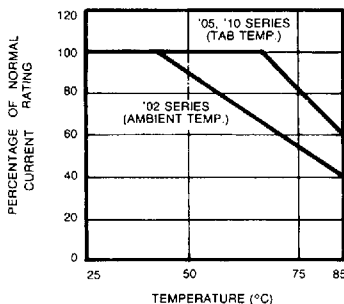

### Forward Voltage vs. Load

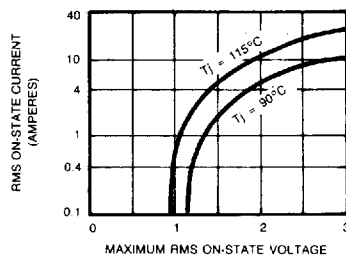

### Typical Application

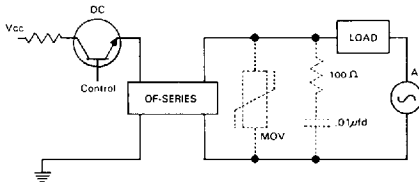

Under certain low power factor load conditions, it may be advisable to connect an RC snubber network across the SSR output. With low power factor loads, phase shifts occur which alter the circuit synchronization and prevent SSR turn-on. A snubber capacitor as small as .01  $\mu$ F compensates for the phase shift and returns the SSR to proper input signal response.

A snubber is also useful in the event of severe high voltage line spikes. While these do not generally cause damage to the SSR, they may induce false 1/2 cycle turn-on.

### Load Current with Heat Sinks

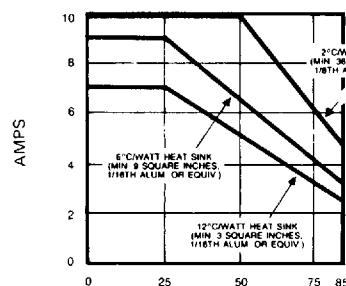
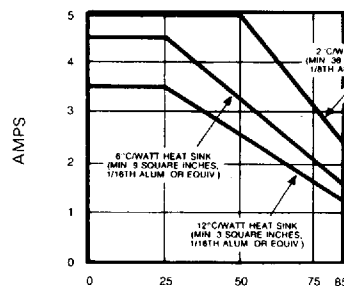

**6 Pin Through Hole (Standard)**

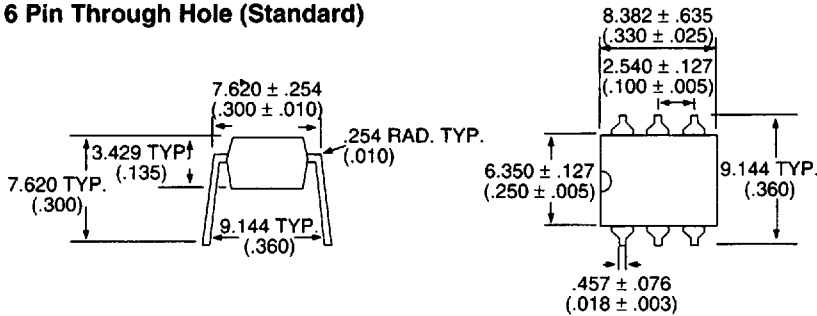

**6 Pin PC Board Pattern (Bottom View)**

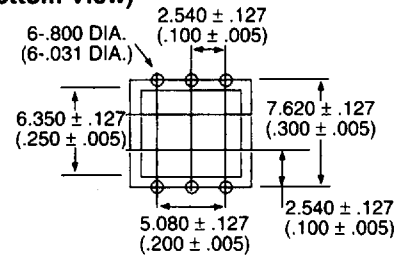

**6 Pin Surface Mount ("S" Suffix)**

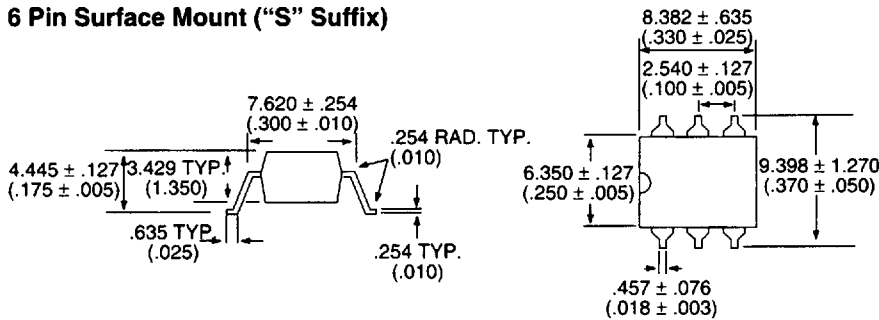

**6 Pin Mounting Pad (Top View)**

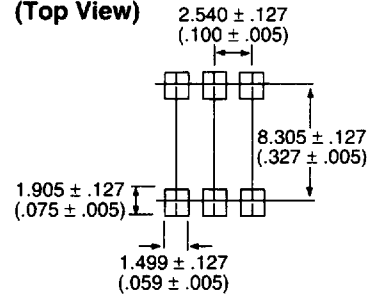

**8 Pin Through Hole (Standard)**

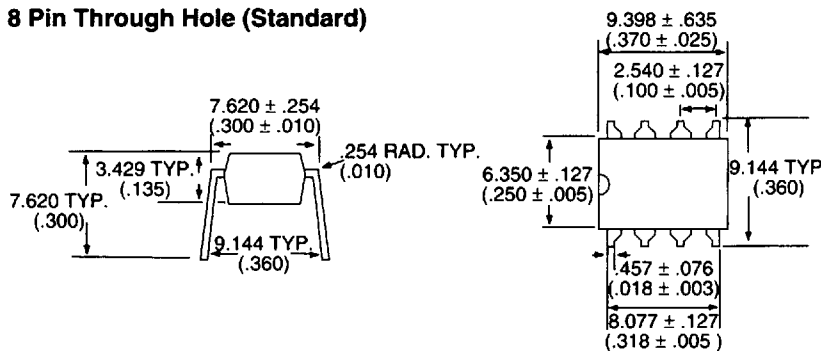

**8 Pin PC Board Pattern (Bottom View)**

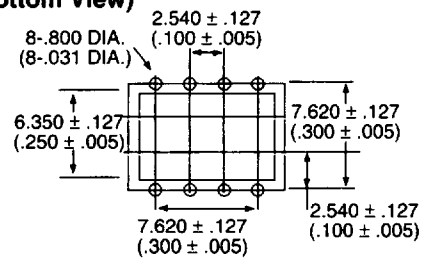

**8 Pin Surface Mount ("S" Suffix)**

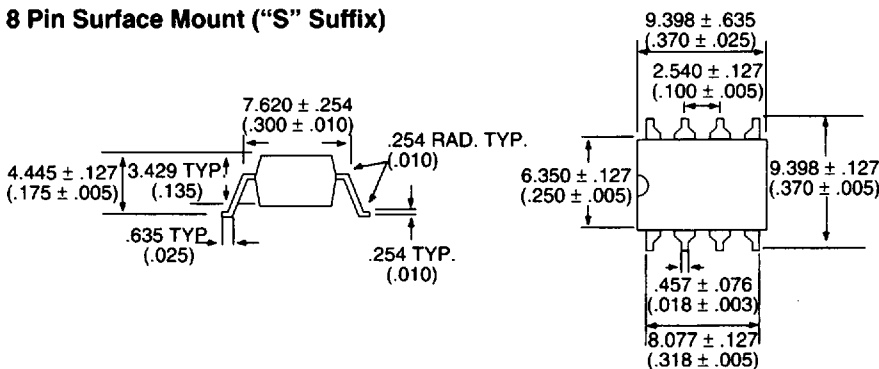

**8 Pin Mounting Pad (Top View)**

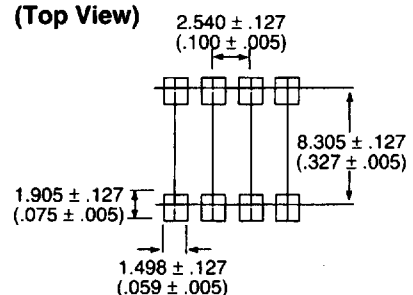

**DIMENSIONS**  
mm  
(Inches)

**8 Pin Flatpack ("P" Suffix)**

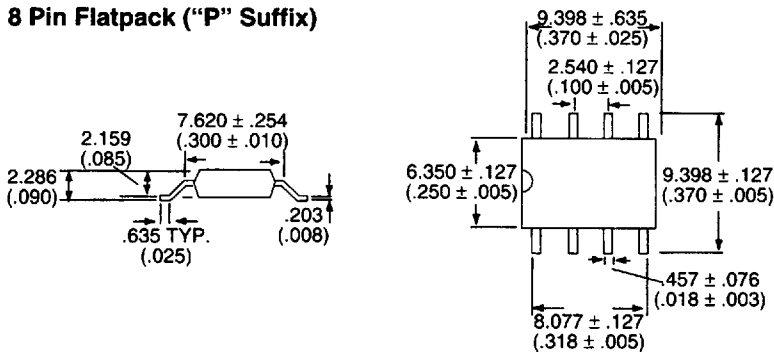

**8 Pin Flatpack Mounting Pad (Top View)**

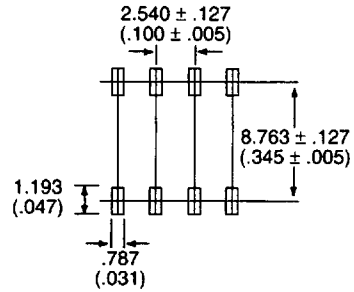

**16 Pin SOIC ("P" Suffix)**

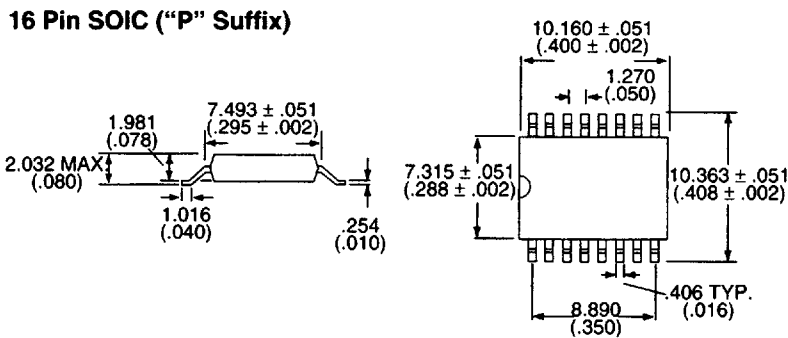

**16 Pin SOIC Mounting Pad (Top View)**

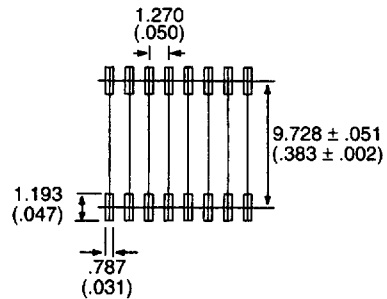

**16 Pin Through Hole (Standard)**

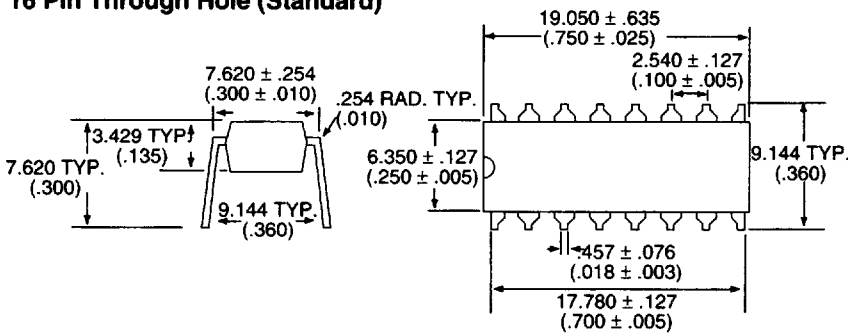

**16 Pin PC Board Pattern (Bottom View)**

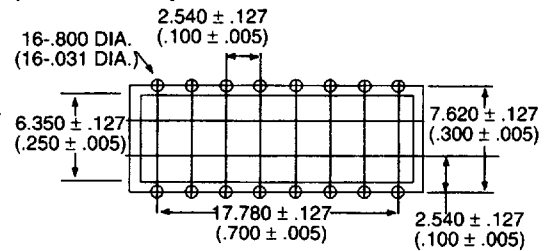

**8 Pin SIP**

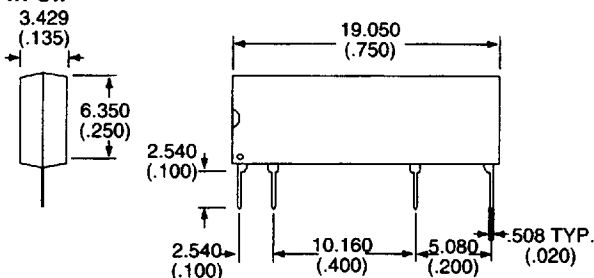

**DIMENSIONS**  
mm  
(Inches)

**16 Pin DIP**

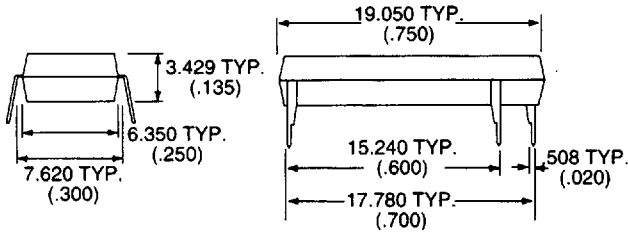

**Thermal Clip**

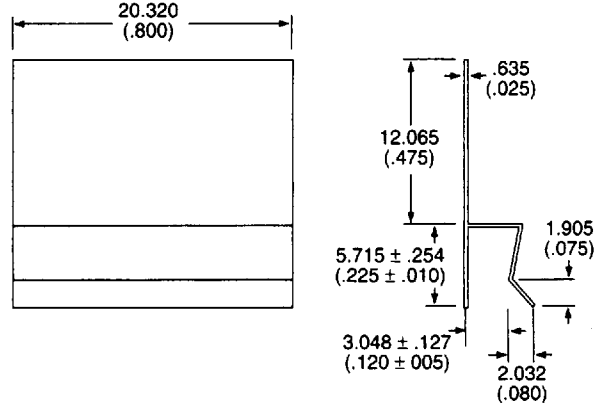

**OptoFILM® 10A Series, Pins**

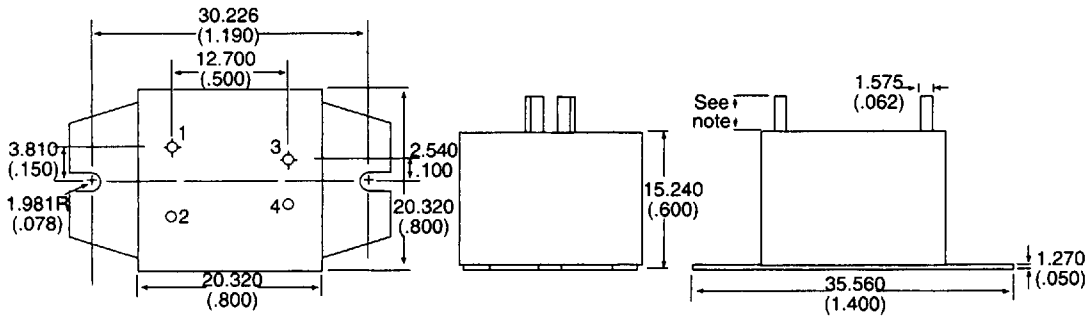

Note: Specify "-1" (0.300" pins)  
 Specify "-3" (0.175" pins)

**OptoFILM® 10A Series, Quick Connect**

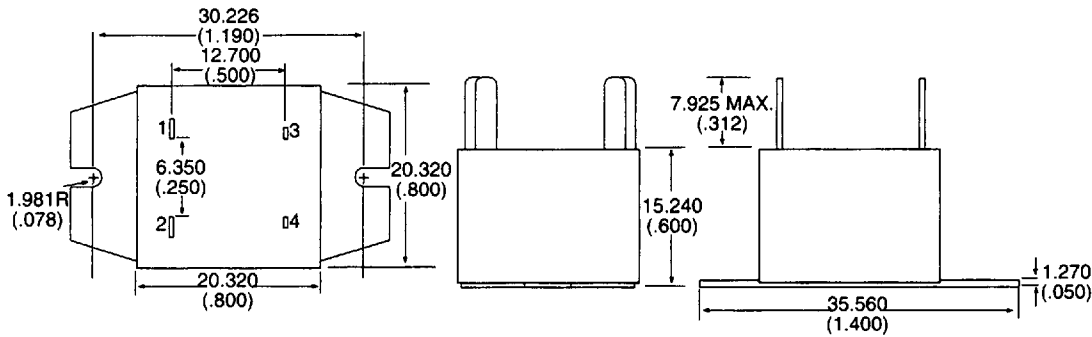

**Tape and Reel Packaging for 6 Pin Surface Mount Package**

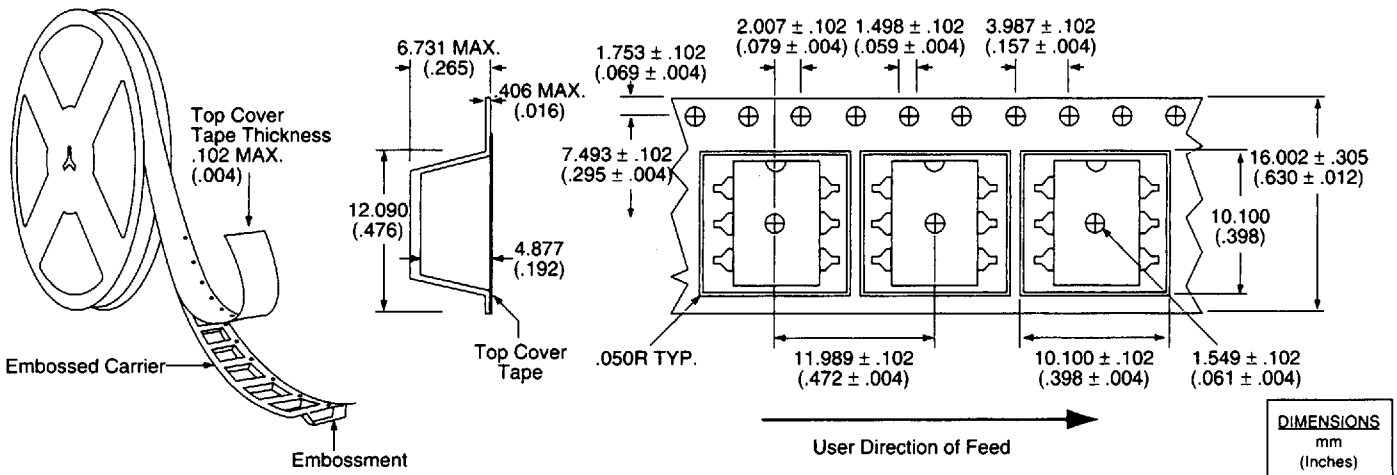

**Tape and Reel Packaging for 8 Pin Surface Mount Package**

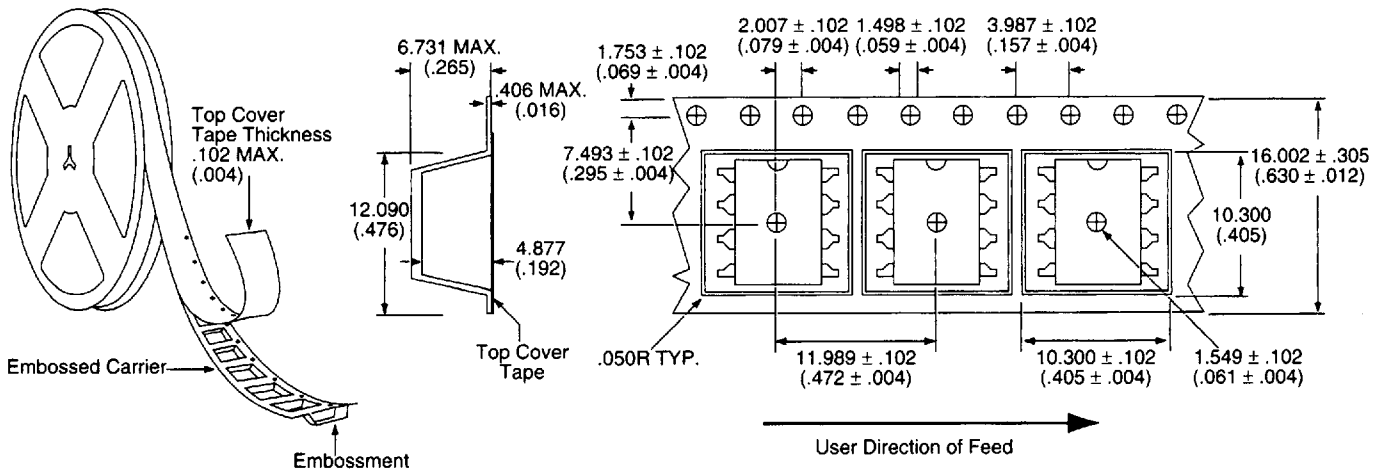

**Tape and Reel Packaging for 8 Pin Flatpack Package**

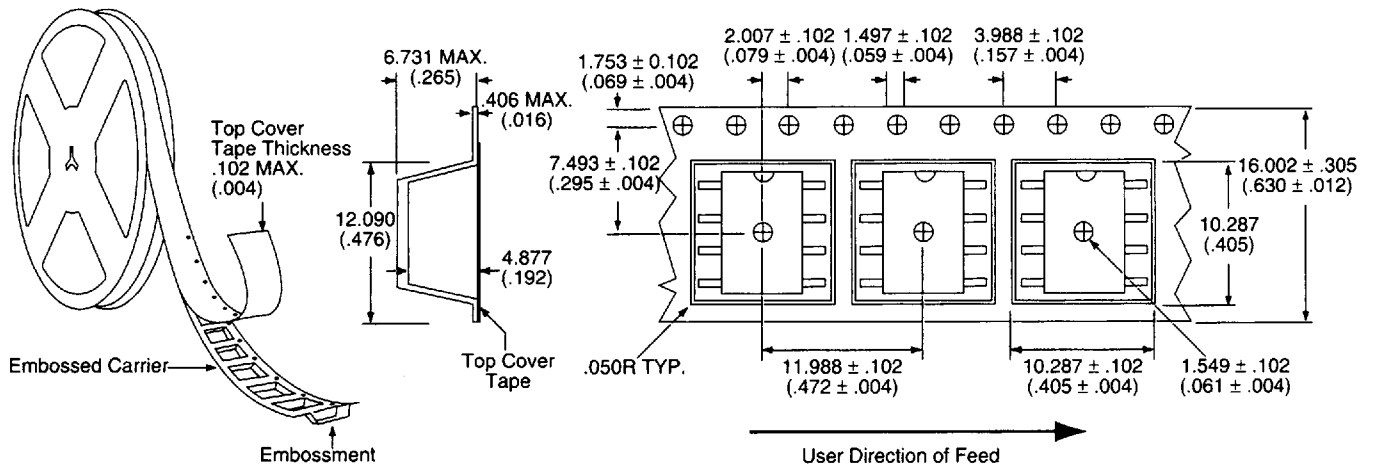

**Tape and Reel Packaging for 16 Pin SOIC Package**

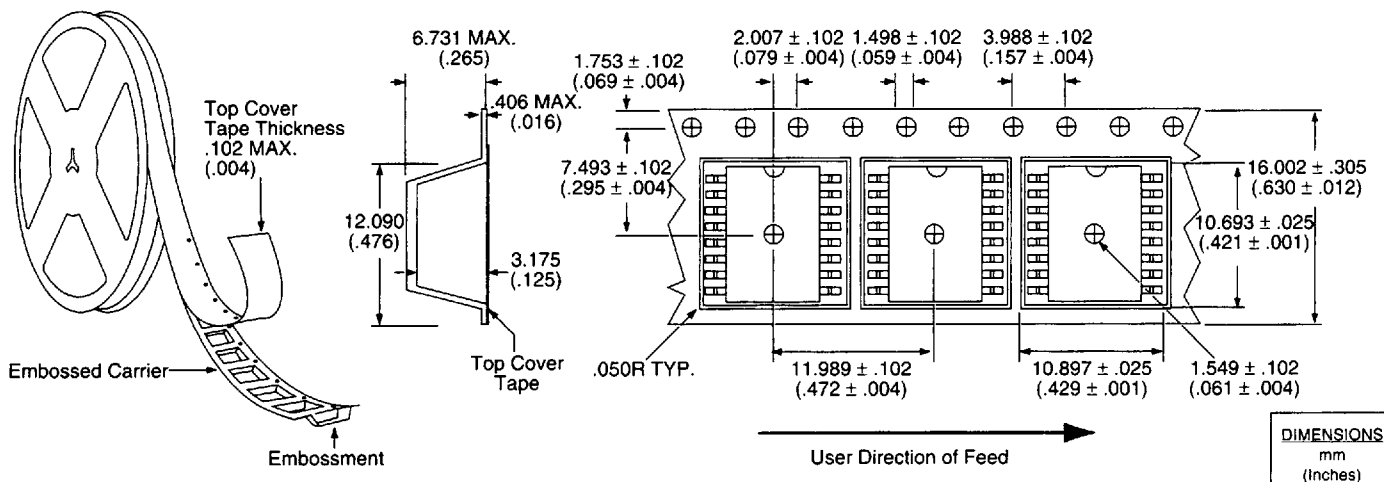

**DIMENSIONS**  
mm  
(Inches)