



Low Voltage Micropower Quad Operational Amplifier

OP490

FEATURES

Single/Dual Supply Operation
 +1.6 V to +36 V
 ±0.8 V to ±18 V

True Single-Supply Operation; Input and Output Voltage Ranges Include Ground

Low Supply Current: 80 μ A max
 High Output Drive: 5 mA min
 Low Offset Voltage: 0.5 mV max
 High Open-Loop Gain: 700 V/mV min
 Outstanding PSRR: 5.6 μ V/V min
 Industry Standard Quad Pinouts
 Available in Die Form

GENERAL DESCRIPTION

The OP490 is a high-performance micropower quad op amp that operates from a single supply of +1.6 V to +36 V or from dual supplies of ±0.8 V to ±18 V. Input voltage range includes the negative rail allowing the OP490 to accommodate input signals down to ground in single-supply operation. The OP490's output swing also includes ground when operating from a single supply, enabling "zero-in, zero-out" operation.

The quad OP490 draws less than 20 μ A of quiescent supply current per amplifier, but each amplifier is able to deliver over 5 mA of output current to a load. Input offset voltage is under 0.5 mV with offset drift below 5 μ V/°C over the military temperature range. Gain exceeds over 700,000 and CMR is better than 100 dB. A PSRR of under 5.6 μ V/V minimizes offset voltage changes experienced in battery powered systems.

The quad OP490 combines high performance with the space and cost savings of quad amplifiers. The minimal voltage and current requirements of the OP490 makes it ideal for battery and solar powered applications, such as portable instruments and remote sensors.

PIN CONNECTION

14-Pin Hermetic DIP (Y-Suffix)
 14-Pin Plastic DIP (P-Suffix)

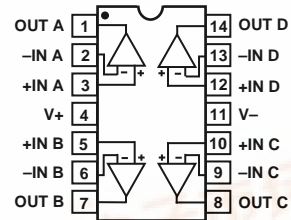

16-Pin SOL (S-Suffix)

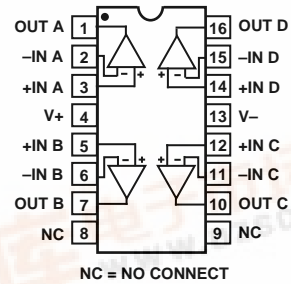

28-Pin LCC (TC-Suffix)

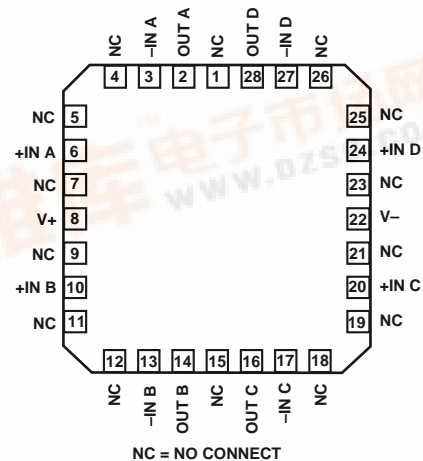

REV. B

Information furnished by Analog Devices is believed to be accurate and reliable. However, no responsibility is assumed by Analog Devices for its use, nor for any infringements of patents or other rights of third parties which may result from its use. No license is granted by implication or otherwise under any patent or patent rights of Analog Devices.

OP490–SPECIFICATIONS

ELECTRICAL CHARACTERISTICS (@ $V_S = \pm 1.5\text{ V}$ to $\pm 15\text{ V}$, $T_A = +25^\circ\text{C}$, unless otherwise noted)

Parameter	Symbol	Conditions	OP490A/E			OP490F			OP490G			Units
			Min	Typ	Max	Min	Typ	Max	Min	Typ	Max	
INPUT OFFSET VOLTAGE	V_{OS}		0.2	0.5		0.4	0.75		0.6	1.0	mV	
INPUT OFFSET CURRENT	I_{OS}	$V_{CM} = 0\text{ V}$	0.4	3		0.4	5		0.4	5	nA	
INPUT BIAS CURRENT	I_B	$V_{CM} = 0\text{ V}$	4.2	15		4.2	20		4.2	25	nA	
LARGE SIGNAL VOLTAGE GAIN	A_{VO}	$V_S = \pm 15\text{ V}$, $V_O = \pm 10\text{ V}$ $R_L = 100\text{ k}\Omega$ $R_L = 10\text{ k}\Omega$ $R_L = 2\text{ k}\Omega$ $V_+ = 5\text{ V}$, $V_- = 0\text{ V}$, $1\text{ V} < V_O < 4\text{ V}$ $R_L = 100\text{ k}\Omega$ $R_L = 10\text{ k}\Omega$	700 350 125	1200 600 250		500 250 100	1000 500 200		400 200 100	800 400 200	V/mV	
INPUT VOLTAGE RANGE	IVR	$V_+ = 5\text{ V}$, $V_- = 0\text{ V}$ $V_S = \pm 15\text{ V}^1$	0/4 -15/13.5			0/4 -15/13.5			0/4 -15/13.5		V	
OUTPUT VOLTAGE SWING	V_O V_{OH} V_{OL}	$V_S = \pm 15\text{ V}$ $R_L = 10\text{ k}\Omega$ $R_L = 2\text{ k}\Omega$ $V_+ = 5\text{ V}$, $V_- = 0\text{ V}$ $R_L = 2\text{ k}\Omega$ $V_+ = 5\text{ V}$, $V_- = 0\text{ V}$ $R_L = 10\text{ k}\Omega$	± 13.5 ± 10.5	± 14.2 ± 11.5		± 13.5 ± 10.5	± 14.2 ± 11.5		± 13.5 ± 10.5	± 14.2 ± 11.5	V V μV	
COMMON-MODE REJECTION	CMR	$V_+ = 5\text{ V}$, $V_- = 0\text{ V}$, $0\text{ V} < V_{CM} < 4\text{ V}$ $V_S = \pm 15\text{ V}$, $-15\text{ V} < V_{CM} < 13.5\text{ V}$	90 100	110 130		80 90	100 120		80 90	100 120	dB	
POWER SUPPLY REJECTION RATIO	PSRR			1.0 5.6			3.2 10			3.2 10	$\mu\text{V/V}$	
SLEW RATE	SR	$V_S = \pm 15\text{ V}$	5	12		5	12		5	12	V/ms	
SUPPLY CURRENT (ALL AMPLIFIERS)	I_{SY}	$V_S = \pm 1.5\text{ V}$, No Load $V_S = \pm 15\text{ V}$, No Load	40 60	60 80		40 60	60 80		40 60	60 80	μA	
CAPACITIVE LOAD STABILITY		$A_V = +1$		650			650			650	pF	
INPUT NOISE VOLTAGE	e_n p-p	$f_O = 0.1\text{ Hz}$ to 10 Hz $V_S = \pm 15\text{ V}$		3			3			3	$\mu\text{V p-p}$	
INPUT RESISTANCE DIFFERENTIAL MODE	R_{IN}	$V_S = \pm 15\text{ V}$		30			30			30	M Ω	
INPUT RESISTANCE COMMON MODE	R_{INCM}	$V_S = \pm 15\text{ V}$		20			20			20	G Ω	
GAIN BANDWIDTH PRODUCT	GBWP	$A_V = +1$		20			20			20	kHz	
CHANNEL SEPARATION	CS	$f_O = 10\text{ Hz}$ $V_O = 20\text{ V p-p}$ $V_S = \pm 15\text{ V}^2$	120	150		120	150		120	150	dB	

NOTES

¹Guaranteed by CMR test.

²Guaranteed but not 100% tested.

Specifications subject to change without notice.

ELECTRICAL CHARACTERISTICS (@ $V_S = \pm 1.5 \text{ V}$ to $\pm 15 \text{ V}$, $-55^\circ\text{C} \leq T_A \leq +125^\circ\text{C}$, unless otherwise noted)

Parameter	Symbol	Conditions	OP490A			Units
			Min	Typ	Max	
INPUT OFFSET VOLTAGE	V_{OS}			0.4	1.0	mV
AVERAGE INPUT OFFSET VOLTAGE DRIFT	TCV_{OS}	$V_S = \pm 15 \text{ V}$		2	5	$\mu\text{V}/^\circ\text{C}$
INPUT OFFSET CURRENT	I_{OS}	$V_{CM} = 0 \text{ V}$		1.5	5	nA
INPUT BIAS CURRENT	I_B	$V_{CM} = 0 \text{ V}$		4.4	20	nA
LARGE-SIGNAL VOLTAGE GAIN	A_{VO}	$V_S = \pm 15 \text{ V}$, $V_O = \pm 10 \text{ V}$ $R_L = 100 \text{ k}\Omega$ $R_L = 10 \text{ k}\Omega$ $R_L = 2 \text{ k}\Omega$ $V_+ = 5 \text{ V}$, $V_- = 0 \text{ V}$, $1 \text{ V} < V_O < 4 \text{ V}$ $R_L = 100 \text{ k}\Omega$ $R_L = 10 \text{ k}\Omega$	225	400		V/mV
			125	240		
			50	110		
			100	200		
			50	110		
INPUT VOLTAGE RANGE	IVR	$V_+ = 5 \text{ V}$, $V_- = 0 \text{ V}$ $V_S = \pm 15 \text{ V}^1$	0/3.5 -15/13.5			V
OUTPUT VOLTAGE SWING	V_O	$V_S = \pm 15 \text{ V}$ $R_L = 10 \text{ k}\Omega$ $R_L = 2 \text{ k}\Omega$	± 13 ± 10	± 13.7 ± 11		V
	V_{OH}	$V_+ = 5 \text{ V}$, $V_- = 0 \text{ V}$ $R_L = 2 \text{ k}\Omega$	3.9	4.1		V
	V_{OL}	$V_+ = 5 \text{ V}$, $V_- = 0 \text{ V}$ $R_L = 10 \text{ k}\Omega$		100	500	μV
COMMON-MODE REJECTION	CMR	$V_+ = 5 \text{ V}$, $V_- = 0 \text{ V}$, $0 \text{ V} < V_{CM} < 3.5 \text{ V}$ $V_S = \pm 15 \text{ V}$, $-15 \text{ V} < V_{CM} < 13.5 \text{ V}$	85 95	105 115		dB
POWER SUPPLY REJECTION RATIO	PSRR			3.2	10	$\mu\text{V}/\text{V}$
SUPPLY CURRENT (ALL AMPLIFIERS)	I_{SY}	$V_S = \pm 1.5 \text{ V}$, No Load $V_S = \pm 15 \text{ V}$, No Load		70 90	100 120	μA

NOTES

¹Guaranteed by CMR test.

Specifications subject to change without notice.

OP490-SPECIFICATIONS

ELECTRICAL CHARACTERISTICS (@ $V_S = \pm 1.5 \text{ V}$ to $\pm 15 \text{ V}$, $-25^\circ\text{C} \leq T_A \leq +85^\circ\text{C}$ for OP490E/F, $-40^\circ\text{C} \leq T_A \leq +85^\circ\text{C}$ for OP490G, unless otherwise noted)

Parameter	Symbol	Conditions	OP490E			OP490F			OP490G			Units
			Min	Typ	Max	Min	Typ	Max	Min	Typ	Max	
INPUT OFFSET VOLTAGE	V_{OS}		0.32	0.8		0.6	1.35		0.8	1.5	mV	
AVERAGE INPUT OFFSET VOLTAGE DRIVE	TCV_{OS}	$V_S = \pm 15 \text{ V}$	2	5		4			4		$\mu\text{V}/^\circ\text{C}$	
INPUT OFFSET CURRENT	I_{OS}	$V_{CM} = 0 \text{ V}$	0.8	3		1.0	5		1.3	7	nA	
INPUT BIAS CURRENT	I_B	$V_{CM} = 0 \text{ V}$	4.4	15		4.4	20		4.4	25	nA	
LARGE SIGNAL VOLTAGE GAIN	A_{VO}	$V_S = \pm 15 \text{ V}$, $V_O = \pm 10 \text{ V}$ $R_L = 100 \text{ k}\Omega$ $R_L = 10 \text{ k}\Omega$ $R_L = 2 \text{ k}\Omega$ $V_+ = 5 \text{ V}$, $V_- = 0 \text{ V}$, $1 \text{ V} < V_O < 4 \text{ V}$ $R_L = 100 \text{ k}\Omega$ $R_L = 10 \text{ k}\Omega$	500	800		350	700		300	600		V/mV
			250	400		175	250		150	250		
			100	200		75	150		75	125		
			150	280		100	220		80	160		
INPUT VOLTAGE RANGE	IVR	$V_+ = 5 \text{ V}$, $V_- = 0 \text{ V}$ $V_S = \pm 15 \text{ V}^1$	0/3.5			0/3.5			0/3.5			V
			-15/13.5			-15/13.5			-15/13.5			
OUTPUT VOLTAGE SWING	V_O V_{OH} V_{OL}	$V_S = \pm 15 \text{ V}$ $R_L = 10 \text{ k}\Omega$ $R_L = 2 \text{ k}\Omega$ $V_+ = 5 \text{ V}$, $V_- = 0 \text{ V}$ $R_L = 2 \text{ k}\Omega$ $V_+ = 5 \text{ V}$, $V_- = 0 \text{ V}$ $R_L = 10 \text{ k}\Omega$	± 13	± 14		± 13	± 14		± 13	± 14		V
			± 10	± 11		± 10	± 11		± 10	± 11		
			3.9	4.1		3.9	4.1		3.9	4.1		
COMMON-MODE REJECTION	CMR	$V_+ = 5 \text{ V}$, $V_- = 0 \text{ V}$, $0 \text{ V} < V_{CM} < 3.5 \text{ V}$ $V_S = \pm 15 \text{ V}$, $-15 \text{ V} < V_{CM} < 13.5 \text{ V}$	90	110		80	100		80	100		dB
			100	120		90	110		90	110		
POWER SUPPLY REJECTION RATIO	PSRR		1.0	5.6		3.2	10		5.6	17.8	$\mu\text{V}/\text{V}$	
SUPPLY CURRENT (ALL AMPLIFIERS)	I_{SY}	$V_S = \pm 1.5 \text{ V}$, No Load	65	100		65	100		60	100	μA	
		$V_S = \pm 15 \text{ V}$, No Load	80	120		80	120		75	120		

NOTES

¹Guaranteed by CMR test.

Specifications subject to change without notice.

SIMPLIFIED SCHEMATIC

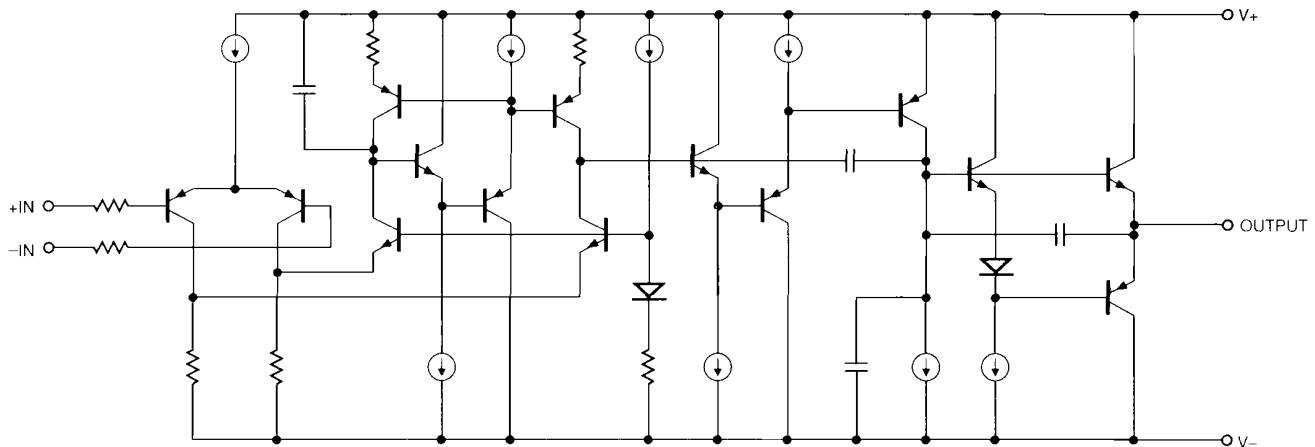

Wafer Test Limits (@ $V_S = \pm 1.5\text{ V}$ to $\pm 15\text{ V}$, $T_A = +25^\circ\text{C}$, unless otherwise noted)

Parameter	Symbol	Conditions	Limits	Units
Input Offset Voltage	V_{OS}		0.75	mV max
Input Offset Current	I_{OS}	$V_{CM} = 0\text{ V}$	5	nA max
Input Bias Current	I_B	$V_{CM} = 0\text{ V}$	20	nA max
Large Signal Voltage Gain	A_{VO}	$V_S = \pm 15\text{ V}$, $V_O = \pm 10\text{ V}$		
		$R_L = 100\text{ k}\Omega$	500	V/mV min
		$R_L = 10\text{ k}\Omega$	250	
Input Voltage Range	IVR	$V_+ = 5\text{ V}$, $V_- = 0\text{ V}$	125	V/mV min
		$1\text{ V} < V_O < 4\text{ V}$, $R_L = 100\text{ k}\Omega$		
		$V_+ = 5\text{ V}$, $V_- = 0\text{ V}$	0/4	V min
Output Voltage Swing	V_O	$V_S = \pm 15\text{ V}$		
		$R_L = 10\text{ k}\Omega$	± 13.5	V min
		$R_L = 2\text{ k}\Omega$	± 10.5	
		$V_+ = 5\text{ V}$, $V_- = 0\text{ V}$		
		$R_L = 2\text{ k}\Omega$	4.0	V min
Common-Mode Rejection	CMR	$V_+ = 5\text{ V}$, $V_- = 0\text{ V}$, $0\text{ V} < V_{CM} < 4\text{ V}$	500	μV max
		$V_S = \pm 15\text{ V}$, $-15\text{ V} < V_{CM} < 13.5\text{ V}$	80	dB min
			90	
Power Supply Rejection Ratio	PSRR		10	$\mu\text{V}/\text{V}$ max
Supply Current (All Amplifiers)	I_{SY}	$V_S = \pm 15\text{ V}$, No Load	80	μA max

NOTES

¹Guaranteed by CMR test.

Electrical tests are performed at wafer probe to the limits shown. Due to variations in assembly methods and normal yield loss, yield after packaging is not guaranteed for standard product dice. Consult factory to negotiate specifications based on dice lot qualifications through sample lot assembly and testing.

ABSOLUTE MAXIMUM RATINGS¹

Supply Voltage	$\pm 18\text{ V}$
Differential Input Voltage	$[(V_-) - 20\text{ V}]$ to $[(V_+) + 20\text{ V}]$
Common-Mode Input Voltage	$[(V_-) - 20\text{ V}]$ to $[(V_+) + 20\text{ V}]$
Output Short-Circuit Duration	Continuous
Storage Temperature Range	
TC, Y, P Package	-65°C to $+150^\circ\text{C}$
Operating Temperature Range	
OP490A	-55°C to $+125^\circ\text{C}$
OP490E, OP490F	-25°C to $+85^\circ\text{C}$
OP490G	-40°C to $+85^\circ\text{C}$
Junction Temperature (T_j)	-65°C to $+150^\circ\text{C}$
Lead Temperature Range (Soldering, 60 sec)	$+300^\circ\text{C}$

Package Type	θ_{JA} ²	θ_{JC}	Units
14-Pin Hermetic DIP (Y)	99	12	$^\circ\text{C}/\text{W}$
14-Pin Plastic DIP (P)	76	33	$^\circ\text{C}/\text{W}$
28-Contact LCC (TC)	78	30	$^\circ\text{C}/\text{W}$
16-Pin SOL (S)	92	27	$^\circ\text{C}/\text{W}$

NOTES

¹Absolute maximum ratings apply to both DICE and packaged parts, unless otherwise noted.

² θ_{JA} is specified for worst case mounting conditions, i.e., θ_{JA} is specified for device in socket for Cerdip, P-DIP, and LCC packages; θ_{JA} is specified for device soldered to printed circuit board for SOL package.

ORDERING GUIDE¹

Model	$T_A = +25^\circ\text{C}$ V_{OS} max (mV)	Operating Temperature Range	Package Description
OP490AY ²	0.5	MIL	14-Pin Cerdip
OP490ATC/883	0.5	MIL	28-Contact LCC
OP490EY	0.5	IND	14-Pin Cerdip
OP490FY	0.75	IND	14-Pin Cerdip
OP490GP	1.0	XIND	14-Pin Plastic DIP
OP490GS ³	1.0	XIND	16-Pin SOL

NOTES

¹Burn-in is available on commercial and industrial temperature range parts in cerdip, plastic DIP and TO-can packages.

²For devices processed in total compliance to MIL-STD-883, add /883 after part number. Consult factory for 883 data sheet.

³For availability and burn-in information on SO and PLCC packages, contact your local sales office.

DICE CHARACTERISTICS

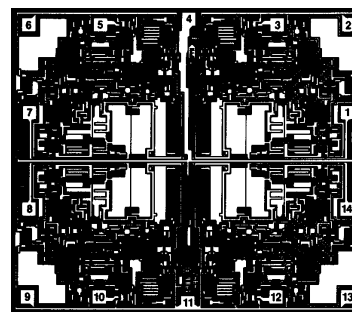

Die Size 0.139 × 0.121 inch, 16,819 sq. mils
(3.53 × 3.07 mm, 10.84 sq. mm)

OP490—Typical Performance Characteristics

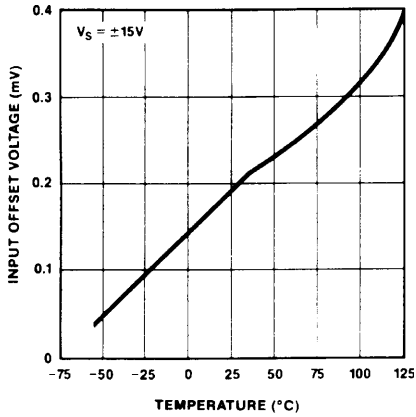

Input Offset Voltage vs. Temperature

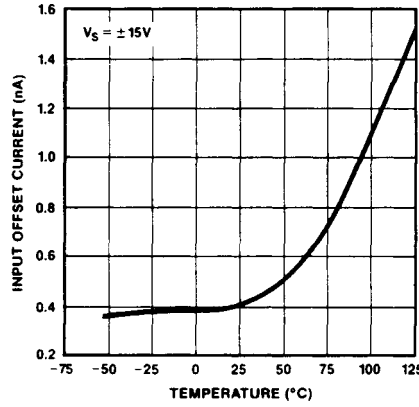

Input Offset Current vs. Temperature

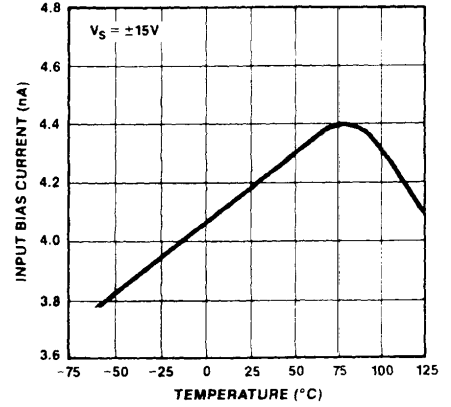

Input Bias Current vs. Temperature

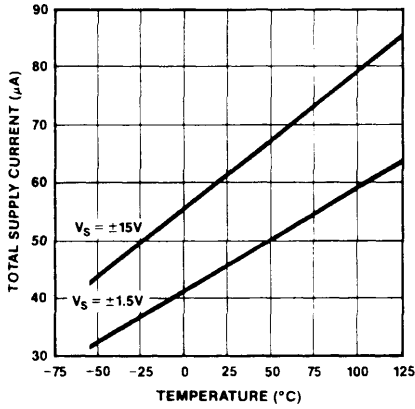

Total Supply Current vs. Temperature

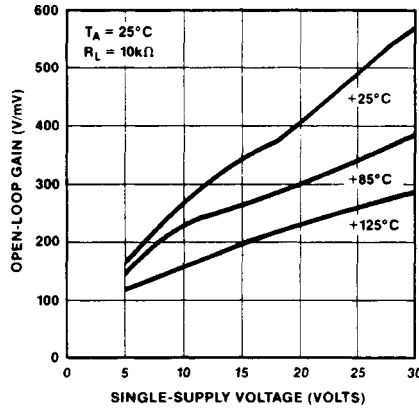

Open-Loop Gain vs. Single-Supply Voltage

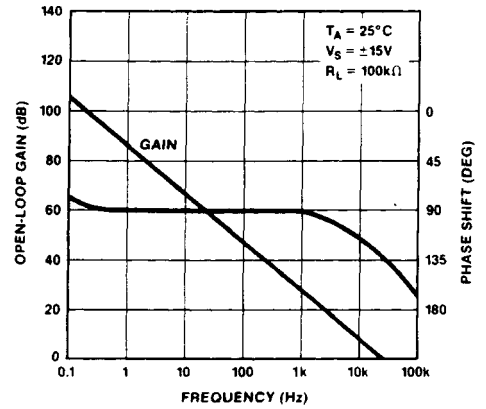

Open-Loop Gain and Phase Shift vs. Frequency

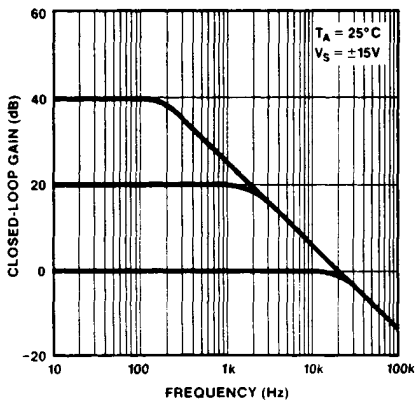

Closed-Loop Gain vs. Frequency

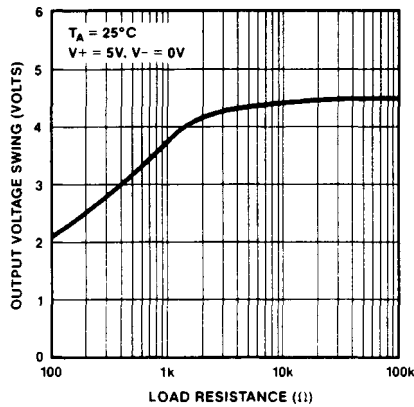

Output Voltage Swing vs. Load Resistance

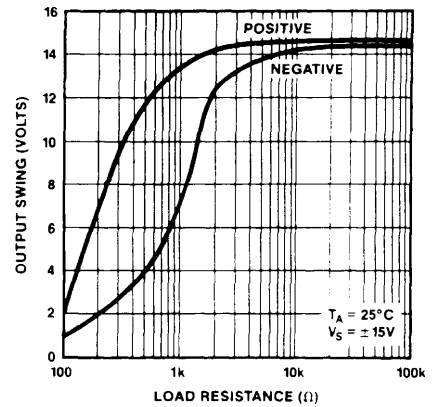

Output Voltage Swing vs. Load Resistance

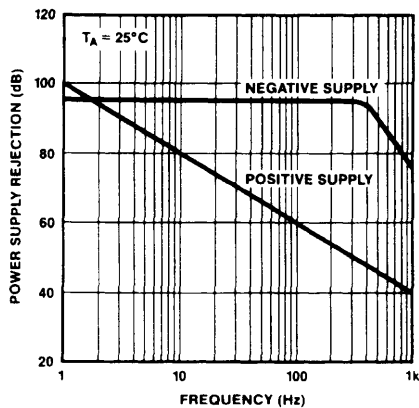

Power Supply Rejection vs. Frequency

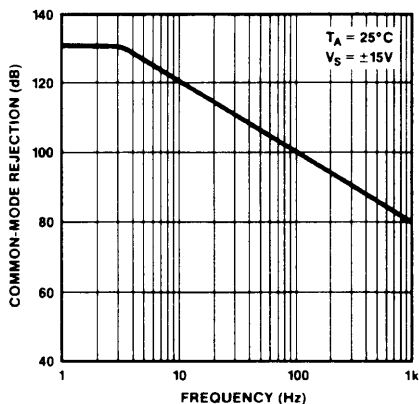

Common-Mode Rejection vs. Frequency

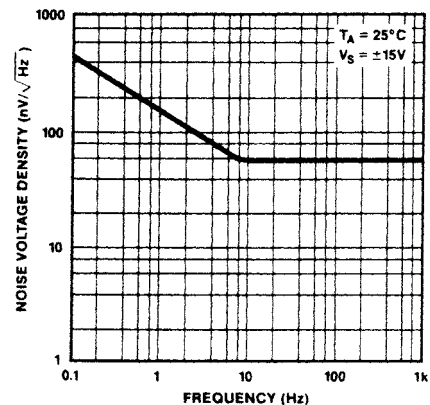

Noise Voltage Density vs. Frequency

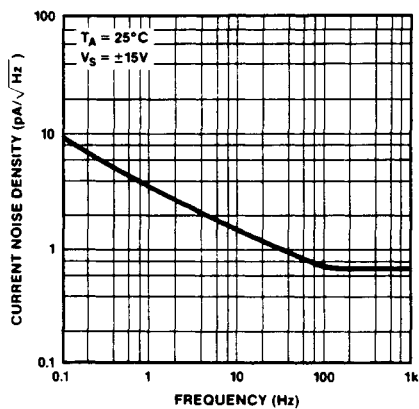

Current Noise Density vs. Frequency

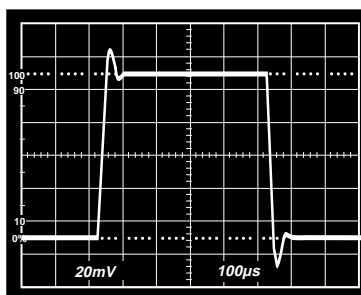

$T_A = 25^\circ\text{C}$
 $V_S = \pm 15\text{V}$
 $A_V = +1$
 $R_L = 10\text{k}\Omega$
 $C_L = 500\text{pF}$

Small-Signal Transient Response

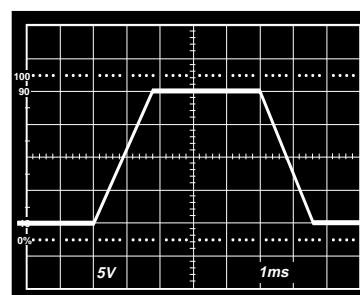

$T_A = 25^\circ\text{C}$
 $V_S = \pm 15\text{V}$
 $A_V = +1$
 $R_L = 10\text{k}\Omega$
 $C_L = 500\text{pF}$

Large-Signal Transient Response

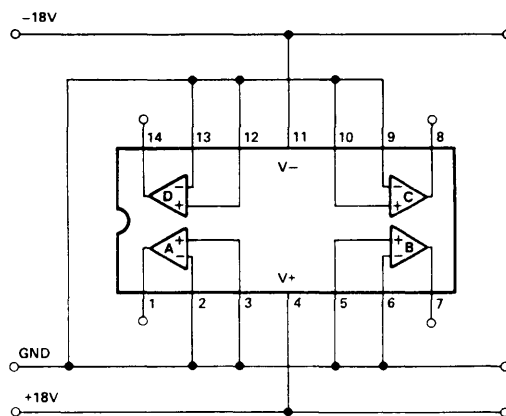

Burn-In Circuit

OP490

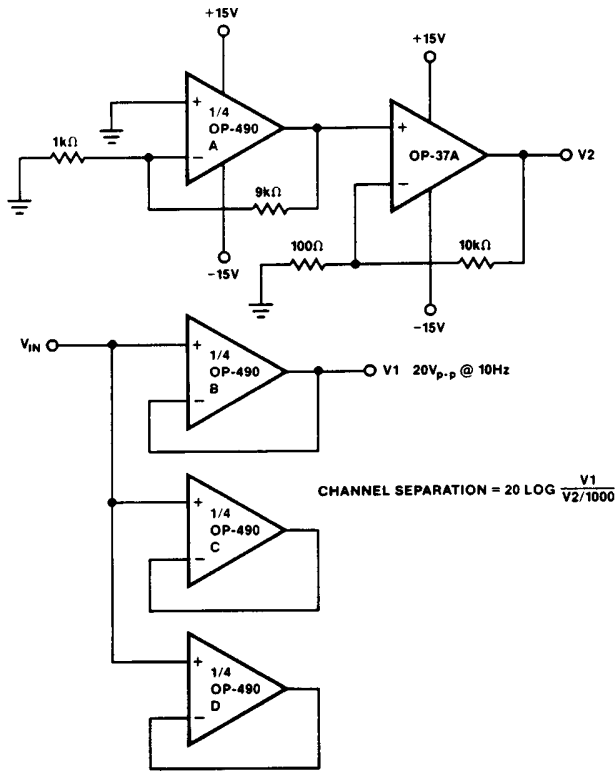

Channel Separation Test Circuit

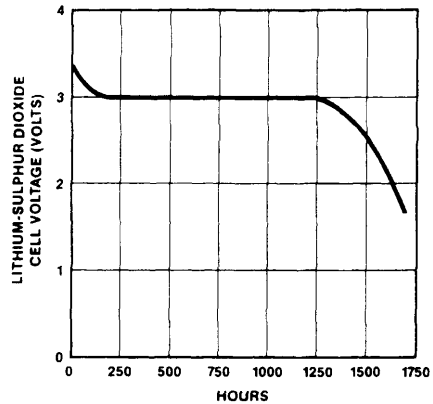

Figure 1. Lithium-Sulphur Dioxide Cell Discharge Characteristic with OP490 and 100 kΩ Loads

requirement of the OP490, combined with the flat discharge characteristic of the lithium cell, indicates that the OP490 can be operated over the entire useful life of the cell. Figure 1 shows the typical discharge characteristic of a 1 Ah lithium cell powering an OP490 with each amplifier, in turn, driving full output swing into a 100 kΩ load.

SINGLE-SUPPLY OUTPUT VOLTAGE RANGE

In single-supply operation the OP490's input and output ranges include ground. This allows true "zero-in, zero-out" operation. The output stage provides an active pull-down to around 0.8 V above ground. Below this level, a load resistance of up to 1 MΩ to ground is required to pull the output down to zero.

In the region from ground to 0.8 V the OP490 has voltage gain equal to the data sheet specification. Output current source capability is maintained over the entire voltage range including ground.

INPUT VOLTAGE PROTECTION

The OP490 uses a PNP input stage with protection resistors in series with the inverting and noninverting inputs. The high breakdown of the PNP transistors coupled with the protection resistors provides a large amount of input protection, allowing the inputs to be taken 20 V beyond either supply without damaging the amplifier.

APPLICATIONS INFORMATION

BATTERY-POWERED APPLICATIONS

The OP490 can be operated on a minimum supply voltage of +1.6 V, or with dual supplies of ±0.8 V, and draws only 60 μA of supply current. In many battery-powered circuits, the OP490 can be continuously operated for hundreds of hours before requiring battery replacement, reducing equipment downtime and operating costs.

High performance portable equipment and instruments frequently use lithium cells because of their long shelf-life, light weight, and high energy density relative to older primary cells. Most lithium cells have a nominal output voltage of 3 V and are noted for a flat discharge characteristic. The low supply current

MICROPOWER VOLTAGE-CONTROLLED OSCILLATOR

An OP490 in combination with an inexpensive quad CMOS switch comprise the precision V_{CO} of Figure 2. This circuit provides triangle and square wave outputs and draws only 75 μ A from a 5 V supply. A acts as an integrator; S1 switches the charging current symmetrically to yield positive and negative ramps. The integrator is bounded by B which acts as a Schmitt trigger with a precise hysteresis of 1.67 volts, set by resistors R5,

R6, and R7, and associated CMOS switches. The resulting output of A is a triangle wave with upper and lower levels of 3.33 and 1.67 volts. The output of B is a square wave with almost rail-to-rail swing. With the components shown, frequency of operation is given by the equation:

$$f_{OUT} = V_{CONTROL} (Volts) \times 10 \text{ Hz/V}$$

but this is easily changed by varying C1. The circuit operates well up to a few hundred hertz.

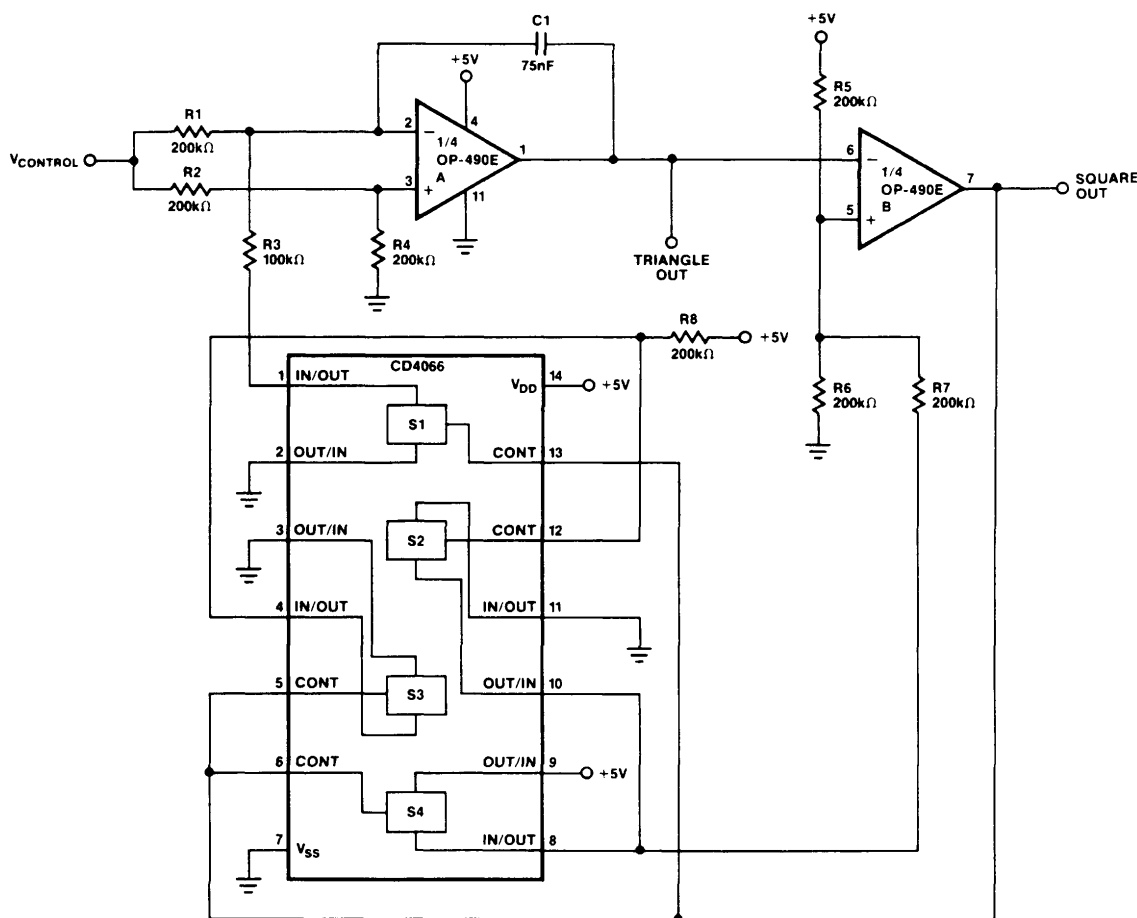

Figure 2. Micropower Voltage Controlled Oscillator

OP490

MICROPOWER SINGLE-SUPPLY QUAD VOLTAGE-OUTPUT 8-BIT DAC

The circuit of Figure 3 uses the DAC8408 CMOS quad 8-bit DAC, and the OP490 to form a single-supply quad voltage-output DAC with a supply drain of only 140 μA . The DAC8408 is

used in voltage switching mode and each DAC has an output resistance ($\approx 10\text{ k}\Omega$) independent of the digital input code. The output amplifiers act as buffers to avoid loading the DACs. The 100 $\text{k}\Omega$ resistors ensure that the OP490 outputs will swing below 0.8 V when required.

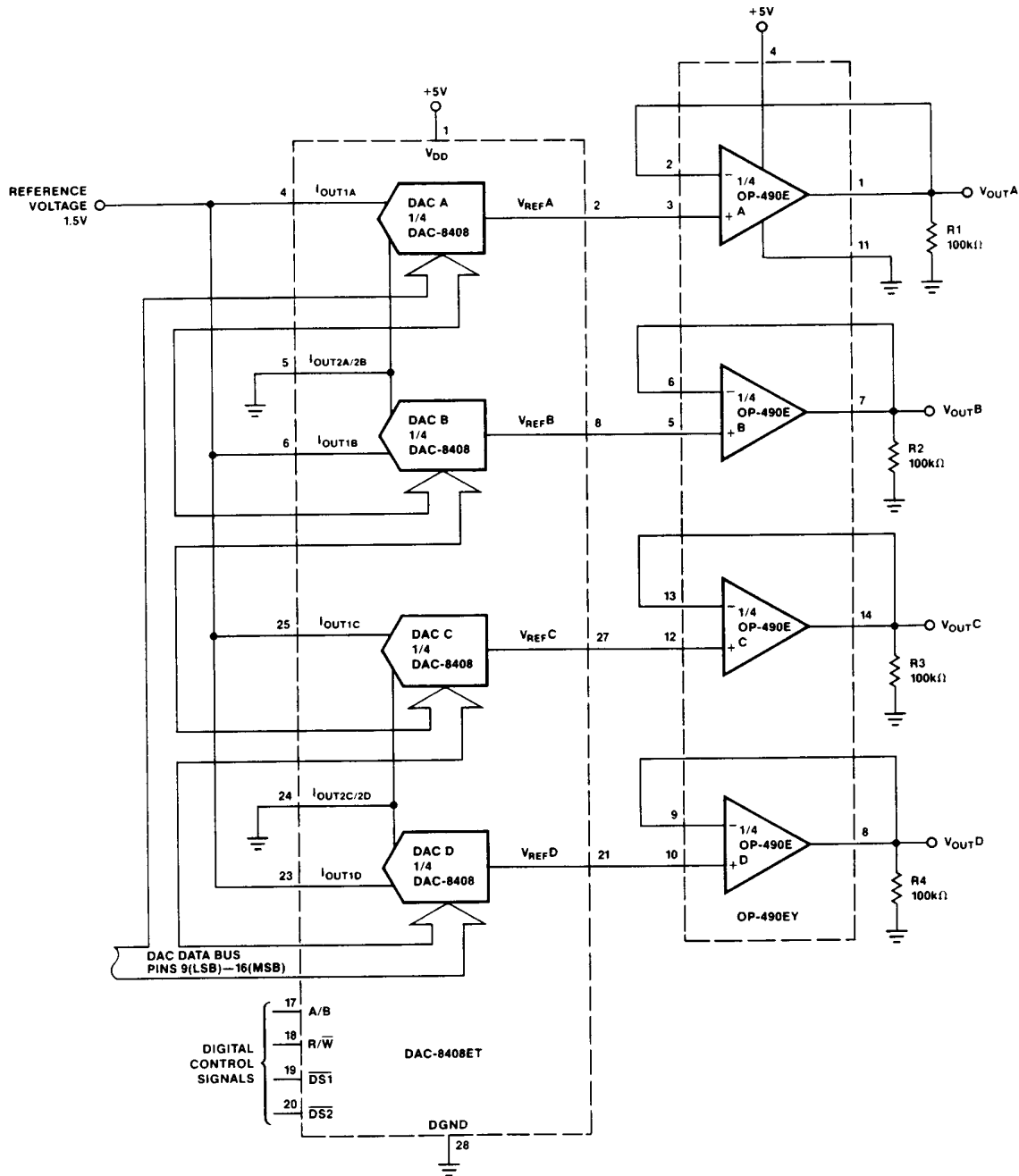

Figure 3. Micropower Single-Supply Quad Voltage Output 8-Bit DAC

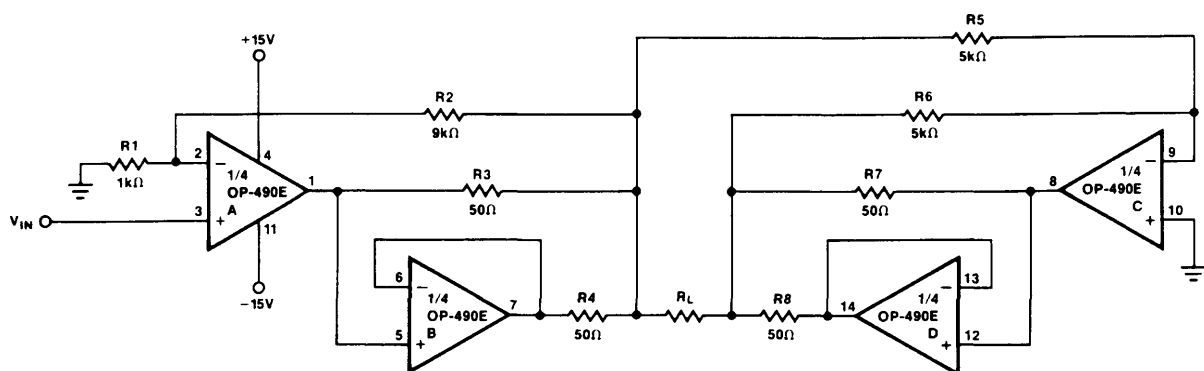

Figure 4. High Output Amplifier

HIGH OUTPUT AMPLIFIER

The amplifier shown in Figure 4 is capable of driving 25 V p-p into a 1 kΩ load. Design of the amplifier is based on a bridge configuration. A amplifies the input signal and drives the load with the help of B. Amplifier C is a unity-gain inverter which drives the load with help from D. Gain of the high output amplifier with the component values shown is 10, but can easily be changed by varying R1 or R2.

SINGLE-SUPPLY MICROPOWER QUAD PROGRAMMABLE GAIN AMPLIFIER

The combination of quad OP490 and the DAC8408 quad 8-bit CMOS DAC, creates a quad programmable-gain amplifier with a quiescent supply drain of only 140 μA. The digital code

present at the DAC, which is easily set by a microprocessor, determines the ratio between the fixed DAC feedback resistor and the resistance of the DAC ladder presents to the op amp feedback loop. Gain of each amplifier is:

$$\frac{V_{OUT}}{V_{IN}} = -\frac{256}{n}$$

where n equals the decimal equivalent of the 8-bit digital code present at the DAC. If the digital code present at the DAC consists of all zeros, the feedback loop will be open causing the op amp output to saturate. The 10 MΩ resistors placed in parallel with the DAC feedback loop eliminates this problem with a very small reduction in gain accuracy. The 2.5 V reference biases the amplifiers to the center of the linear region providing maximum output swing.

OP490

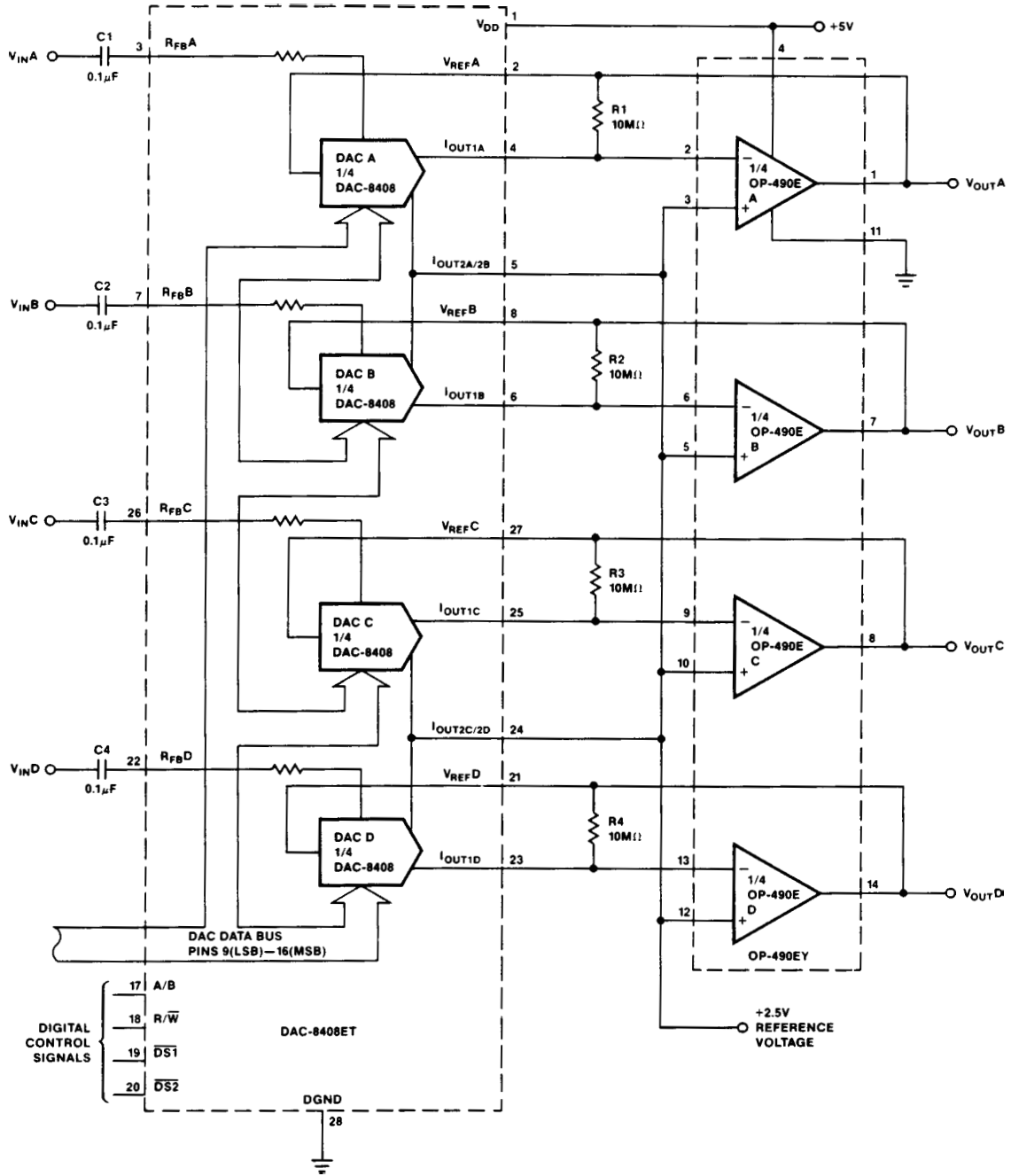

Figure 5. Single Supply Micropower Quad Programmable Gain Amplifier