

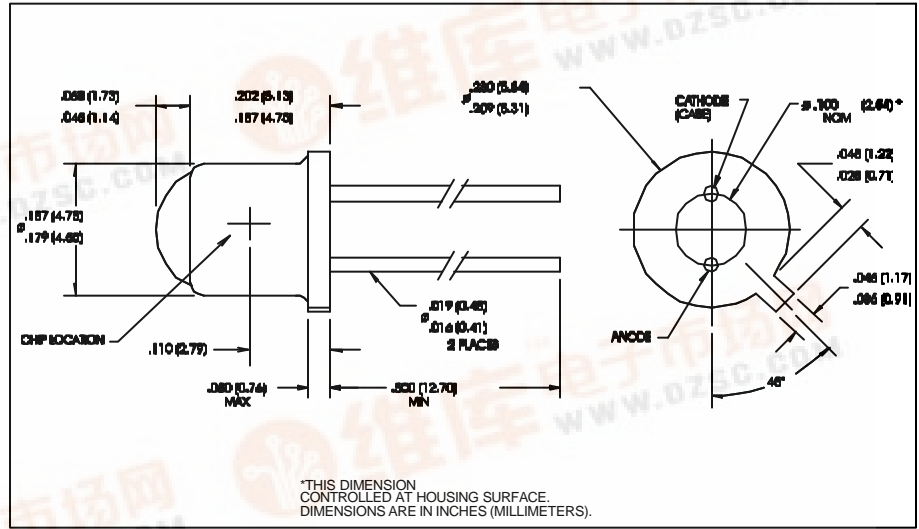

Product Bulletin OP910
December 1998

PIN Silicon Photodiode Type OP910



Features

- Narrow receiving angle
- Fast switching time
- Linear response vs. irradiance
- Enhanced temperature range

Description

The OP910 consists of a PIN silicon photodiode mounted in a two-leaded hermetic TO-46 package. The narrow receiving angle has an acceptance half angle of $\pm 12^\circ$.

Absolute Maximum Ratings ($T_A = 25^\circ\text{C}$ unless otherwise noted)

Reverse Voltage	60 V
Storage Temperature Range	-65°C to $+150^\circ\text{C}$
Operating Temperature Range	-65°C to $+125^\circ\text{C}$
Lead Soldering Temperature [1/16 inch (1.6 mm) from case for 5 sec. with soldering iron]	$260^\circ\text{C}^{(1)}$
Power Dissipation	250 mW

NOTES:

- (1) RMA Flux is recommended. Duration can be extended to 10 sec. max. when flow soldering.
- (2) Light source is an unfiltered GaAlAs LED with a peak wavelength of 885 nm and a radiometric intensity level which varies less than 10% over the entire lens surface of the photodiode being tested.
- (3) Junction temperature maintained at 25°C .
- (4) To calculate typical dark current in nA, use the formula $I_D = 10^{(0.042 T_A - 1.5)}$ where T_A is ambient temperature in $^\circ\text{C}$.
- (5) Derate linearly $2.5\text{ mW}/^\circ\text{C}$ above 25°C .

Typical Performance Curves

Typical Spectral Response

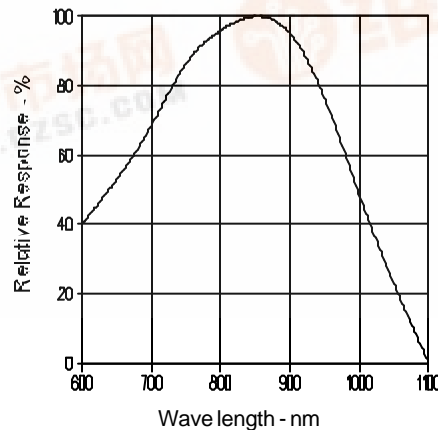

Type OP910

Electrical Characteristics ($T_A = 25^\circ\text{C}$ unless otherwise noted)

SYMBOL	PARAMETER	MIN	TYP	MAX	UNITS	TEST CONDITIONS
I_L	Light Current	10	13		μA	$V_R = 20\text{ V}$, $E_e = .50\text{ mW/cm}^2$ note 2,3
I_D	Dark Current		1	10	nA	$V_R = 20\text{ V}$, $E_e = 0.0$
$V_{(BR)R}$	Reverse Voltage Breakdown	100			V	$I_R = 100\ \mu\text{A}$
t_r	Rise Time		10		nS	$V_R = 20\text{ V}$, $R_L = 50\text{ OHMS}$
t_f	Fall Time		10		nS	$V_R = 20\text{ V}$, $R_L = 50\text{ OHMS}$
\emptyset	Half Angle		+/- 12		degr.	$I_F = \text{Constant}$
C_P	Capacitance		13		pF	$V_R = 0\text{ V}$, $F = 1\text{ MHz}$, $E_e = 0$

PHOTOSENSORS

Typical Performance Curves

Normalized Light Current vs Reverse Voltage

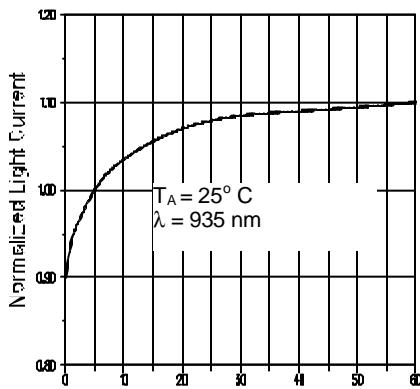

V_R - Reverse Voltage - V

Total Capacitance vs Reverse Voltage

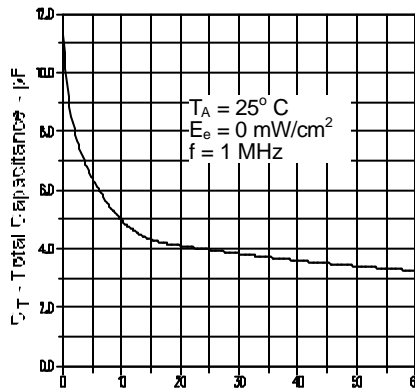

V_R - Reverse Voltage - V

Normalized Light and Dark Current vs Ambient Temperature

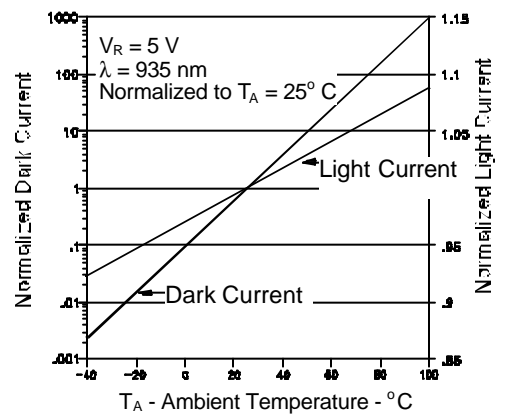

Light Current vs Irradiance

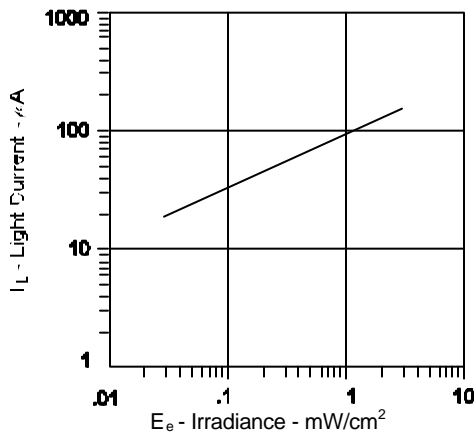

Switching Time Test Circuit

