



OPA121

## Low Cost Precision *Difet*<sup>®</sup> OPERATIONAL AMPLIFIER

### FEATURES

- LOW NOISE:  $6\text{nV}/\sqrt{\text{Hz}}$  typ at 10kHz
- LOW BIAS CURRENT: 5pA max
- LOW OFFSET: 2mV max
- LOW DRIFT:  $3\mu\text{V}/^\circ\text{C}$  typ
- HIGH OPEN-LOOP GAIN: 110dB min
- HIGH COMMON-MODE REJECTION: 86dB min

### APPLICATIONS

- OPTOELECTRONICS
- DATA ACQUISITION
- TEST EQUIPMENT
- MEDICAL EQUIPMENT
- RADIATION HARD EQUIPMENT

### DESCRIPTION

The OPA121 is a precision monolithic dielectrically-isolated FET (*Difet*<sup>®</sup>) operational amplifier. Outstanding performance characteristics are now available for low-cost applications.

Noise, bias current, voltage offset, drift, open-loop gain, common-mode rejection, and power supply rejection are superior to BIFET<sup>®</sup> amplifiers.

Very low bias current is obtained by dielectric isolation with on-chip guarding.

Laser-trimming of thin-film resistors gives very low offset and drift. Extremely low noise is achieved with new circuit design techniques (patented). A new cascode design allows high precision input specifications and reduced susceptibility to flicker noise.

Standard 741 pin configuration allows upgrading of existing designs to higher performance levels.

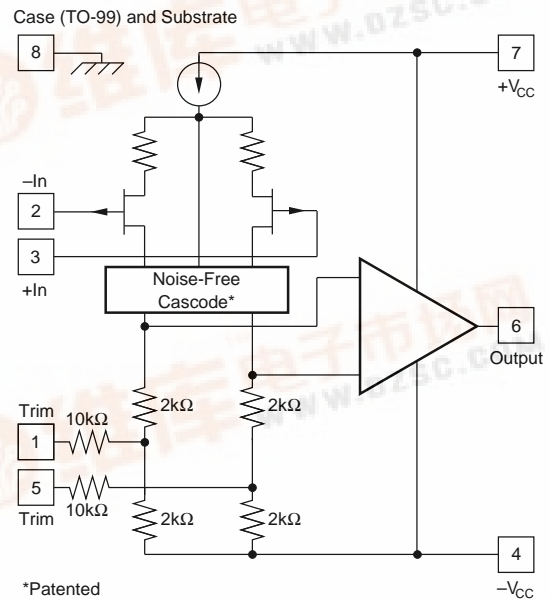

OPA121 Simplified Circuit

*Difet*<sup>®</sup>, Burr-Brown Corp.  
BIFET<sup>®</sup>, National Semiconductor Corp.



# SPECIFICATIONS

## ELECTRICAL

At  $V_{CC} = \pm 15\text{VDC}$  and  $T_A = +25^\circ\text{C}$  unless otherwise noted. Pin 8 connected to ground.

PARAMETER	CONDITIONS	OPA121KM			OPA121KP, KU			UNITS
		MIN	TYP	MAX	MIN	TYP	MAX	
<b>INPUT NOISE</b>								
Voltage, $f_o = 10\text{Hz}$	(1)		40			50		$\text{nV}/\sqrt{\text{Hz}}$
$f_o = 100\text{Hz}$	(1)		15			18		$\text{nV}/\sqrt{\text{Hz}}$
$f_o = 1\text{kHz}$	(1)		8			10		$\text{nV}/\sqrt{\text{Hz}}$
$f_o = 10\text{kHz}$	(1)		6			7		$\text{nV}/\sqrt{\text{Hz}}$
$f_B = 10\text{Hz to } 10\text{kHz}$	(1)		0.7			0.8		$\mu\text{Vrms}$
$f_B = 0.1\text{Hz to } 10\text{Hz}$	(1)		1.6			2		$\mu\text{Vp-p}$
Current, $f_B = 0.1\text{Hz to } 10\text{Hz}$	(1)		15			21		$\text{fA, p-p}$
$f_o = 0.1\text{Hz thru } 20\text{kHz}$	(1)		0.8			1.1		$\text{fA}/\sqrt{\text{Hz}}$
<b>OFFSET VOLTAGE<sup>(2)</sup></b>								
Input Offset Voltage	$V_{CM} = 0\text{VDC}$		$\pm 0.5$	$\pm 2$		$\pm 0.5$	$\pm 3$	mV
Average Drift	$T_A = T_{MIN}$ to $T_{MAX}$		$\pm 3$	$\pm 10$		$\pm 3$	$\pm 10$	$\mu\text{V}/^\circ\text{C}$
Supply Rejection		86	104	$\pm 6$	86	104	$\pm 6$	$\pm 50$
								$\mu\text{V/V}$
<b>BIAS CURRENT<sup>(2)</sup></b>								
Input Bias Current	$V_{CM} = 0\text{VDC}$ Device Operating		$\pm 1$	$\pm 5$		$\pm 1$	$\pm 10$	pA
<b>OFFSET CURRENT<sup>(2)</sup></b>								
Input Offset Current	$V_{CM} = 0\text{VDC}$ Device Operating		$\pm 0.7$	$\pm 4$		$\pm 0.7$	$\pm 8$	pA
<b>IMPEDANCE</b>								
Differential			$10^{13} \parallel 1$			$10^{13} \parallel 1$		$\Omega \parallel \text{pF}$
Common-Mode			$10^{14} \parallel 3$			$10^{14} \parallel 3$		$\Omega \parallel \text{pF}$
<b>VOLTAGE RANGE</b>								
Common-Mode Input Range		$\pm 10$	$\pm 11$		$\pm 10$	$\pm 11$		V
Common-Mode Rejection	$V_{IN} = \pm 10\text{VDC}$	86	104		82	100		dB
<b>OPEN-LOOP GAIN, DC</b>								
Open-Loop Voltage Gain	$R_L \geq 2\text{k}\Omega$	110	120		106	114		dB
<b>FREQUENCY RESPONSE</b>								
Unity Gain, Small Signal			2			2		MHz
Full Power Response	$20\text{Vp-p}, R_L = 2\text{k}\Omega$		32			32		kHz
Slew Rate	$V_O = \pm 10\text{V}, R_L = 2\text{k}\Omega$		2			2		$\text{V}/\mu\text{s}$
Settling Time, 0.1%	Gain = -1, $R_L = 2\text{k}\Omega$		6			6		$\mu\text{s}$
0.01%	10V Step		10			10		$\mu\text{s}$
Overload Recovery, 50% Overdrive <sup>(3)</sup>	Gain = -1		5			5		$\mu\text{s}$
<b>RATED OUTPUT</b>								
Voltage Output	$R_L = 2\text{k}\Omega$	$\pm 11$	$\pm 12$		$\pm 11$	$\pm 12$		V
Current Output	$V_O = \pm 10\text{VDC}$	$\pm 5.5$	$\pm 10$		$\pm 5.5$	$\pm 10$		mA
Output Resistance	DC, Open Loop		100			100		$\Omega$
Load Capacitance Stability	Gain = +1		1000			1000		pF
Short Circuit Current		10	40		10	40		mA
<b>POWER SUPPLY</b>								
Rated Voltage			$\pm 15$			$\pm 15$		VDC
Voltage Range, Derated Performance		$\pm 5$		$\pm 18$	$\pm 5$		$\pm 18$	VDC
Current, Quiescent	$I_O = 0\text{mADC}$		2.5	4		2.5	4.5	mA
<b>TEMPERATURE RANGE</b>								
Specification	Ambient Temperature	0		+70	0		+70	$^\circ\text{C}$
Operating	Ambient Temperature	-40		+85	-25		+85	$^\circ\text{C}$
Storage	Ambient Temperature	-65		+150	-55		+125	$^\circ\text{C}$
$\theta_{\text{Junction-Ambient}}$			200			150 <sup>(4)</sup>		$^\circ\text{C}/\text{W}$

NOTES: (1) Sample tested. (2) Offset voltage, offset current, and bias current are specified with the units fully warmed up. (3) Overload recovery is defined as the time required for the output to return from saturation to linear operation following the removal of a 50% input overdrive. (4)  $100^\circ\text{C}/\text{W}$  for KU grade.

The information provided herein is believed to be reliable; however, BURR-BROWN assumes no responsibility for inaccuracies or omissions. BURR-BROWN assumes no responsibility for the use of this information, and all use of such information shall be entirely at the user's own risk. Prices and specifications are subject to change without notice. No patent rights or licenses to any of the circuits described herein are implied or granted to any third party. BURR-BROWN does not authorize or warrant any BURR-BROWN product for use in life support devices and/or systems.

## ELECTRICAL (FULL TEMPERATURE RANGE SPECIFICATIONS)

At  $V_{CC} = \pm 15\text{VDC}$  and  $T_A = T_{MIN}$  to  $T_{MAX}$  unless otherwise noted.

PARAMETER	CONDITIONS	OPA121KM			OPA121KP, KU			UNITS
		MIN	TYP	MAX	MIN	TYP	MAX	
<b>TEMPERATURE RANGE</b> Specification Range	Ambient Temperature	0		+70	0		+70	°C
<b>INPUT OFFSET VOLTAGE<sup>(1)</sup></b> Input Offset Voltage Average Drift Supply Rejection	$V_{CM} = 0\text{VDC}$		$\pm 1$ $\pm 3$ 94 $\pm 20$	$\pm 3$ $\pm 10$  $\pm 80$		$\pm 1$ $\pm 3$ 94 $\pm 20$	$\pm 5$ $\pm 10$  $\pm 80$	mV $\mu\text{V}/^\circ\text{C}$ dB $\mu\text{V}/\text{V}$
<b>BIAS CURRENT<sup>(1)</sup></b> Input Bias Current	$V_{CM} = 0\text{VDC}$ Device Operating		$\pm 23$	$\pm 115$		$\pm 23$	$\pm 250$	pA
<b>OFFSET CURRENT<sup>(1)</sup></b> Input Offset Current	$V_{CM} = 0\text{VDC}$ Device Operating		$\pm 16$	$\pm 100$		$\pm 16$	$\pm 200$	pA
<b>VOLTAGE RANGE</b> Common-Mode Input Range Common-Mode Rejection	$V_{IN} = \pm 10\text{VDC}$	$\pm 10$ 82	$\pm 11$ 98		$\pm 10$ 80	$\pm 11$ 96		V dB
<b>OPEN-LOOP GAIN, DC</b> Open-Loop Voltage Gain	$R_L \geq 2\text{k}\Omega$	106	116		100	110		dB
<b>RATED OUTPUT</b> Voltage Output Current Output Short Circuit Current	$R_L = 2\text{k}\Omega$ $V_O = \pm 10\text{VDC}$ $V_O = 0\text{VDC}$	$\pm 10.5$ $\pm 5.25$ 10	$\pm 11$ $\pm 10$ 40		$\pm 10.5$ $\pm 5.25$ 10	$\pm 11$ $\pm 10$ 40		V mA mA
<b>POWER SUPPLY</b> Current, Quiescent	$I_O = 0\text{mADC}$		2.5	4.5		2.5	5	mA

NOTE: (1) Offset voltage, offset current, and bias current are measured with the units fully warmed up.

## ABSOLUTE MAXIMUM RATINGS

Supply .....	$\pm 18\text{VDC}$
Internal Power Dissipation <sup>(1)</sup> .....	500mW
Differential Input Voltage .....	$\pm 36\text{VDC}$
Input Voltage Range .....	$\pm 18\text{VDC}$
Storage Temperature Range	
M package .....	$-65^\circ\text{C}$ to $+150^\circ\text{C}$
P, U packages .....	$-55^\circ\text{C}$ to $+125^\circ\text{C}$
Operating Temperature Range	
M package .....	$-40^\circ\text{C}$ to $+85^\circ\text{C}$
P, U packages .....	$-25^\circ\text{C}$ to $+85^\circ\text{C}$
Lead Temperature	
M, P packages (soldering, 10s) .....	$+300^\circ\text{C}$
U package (soldering, 3s) .....	$+260^\circ\text{C}$
Output Short-Circuit Duration <sup>(2)</sup> .....	Continuous
Junction Temperature .....	$+175^\circ\text{C}$

NOTES: (1) Packages must be derated based on  $\theta_{JA} = 150^\circ\text{C}/\text{W}$  (P package);  $\theta_{JA} = 200^\circ\text{C}/\text{W}$  (M package);  $\theta_{JA} = 100^\circ\text{C}/\text{W}$  (U package).  
(2) Short circuit may be to power supply common only. Rating applies to  $+25^\circ\text{C}$  ambient. Observe dissipation limit and  $T_J$ .

## PACKAGE INFORMATION

MODEL	PACKAGE	PACKAGE DRAWING NUMBER <sup>(1)</sup>
OPA121KM	TO-99	001
OPA121KP	8-Pin Plastic DIP	006
OPA121KU	8-Pin SOIC	182

NOTE: (1) For detailed drawing and dimension table, please see end of data sheet, or Appendix D of Burr-Brown IC Data Book.

## ORDERING INFORMATION

MODEL	PACKAGE	TEMPERATURE RANGE
OPA121KM	TO-99	$0^\circ\text{C}$ to $+70^\circ\text{C}$
OPA121KP	8-Pin Plastic DIP	$0^\circ\text{C}$ to $+70^\circ\text{C}$
OPA121KU	8-Pin SOIC	$0^\circ\text{C}$ to $+70^\circ\text{C}$

## CONNECTION DIAGRAMS

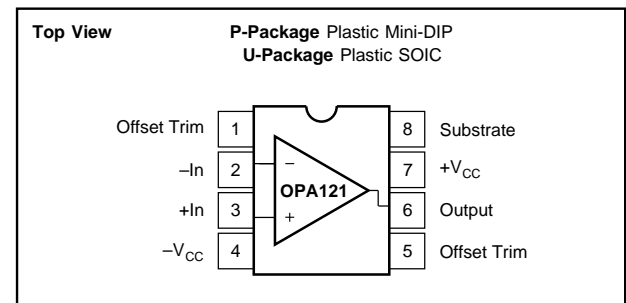
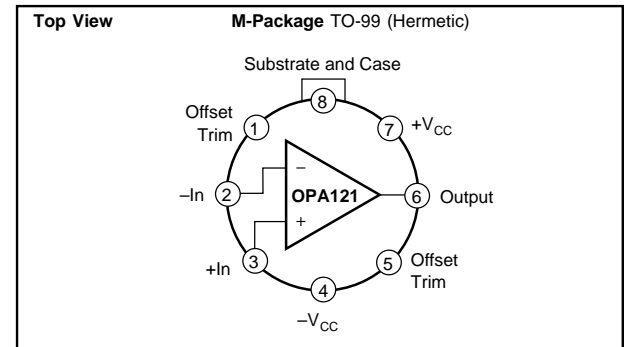

# TYPICAL PERFORMANCE CURVES

$T_A = +25^\circ\text{C}$ ,  $V_{CC} = \pm 15\text{VDC}$  unless otherwise noted.

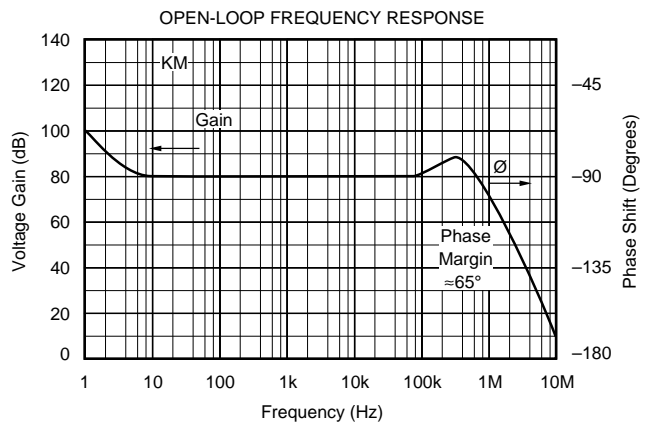
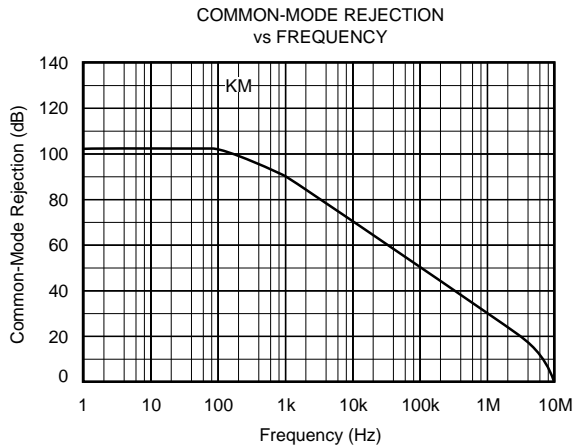
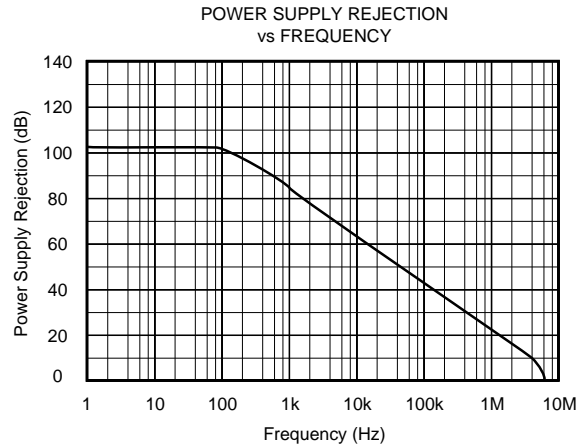
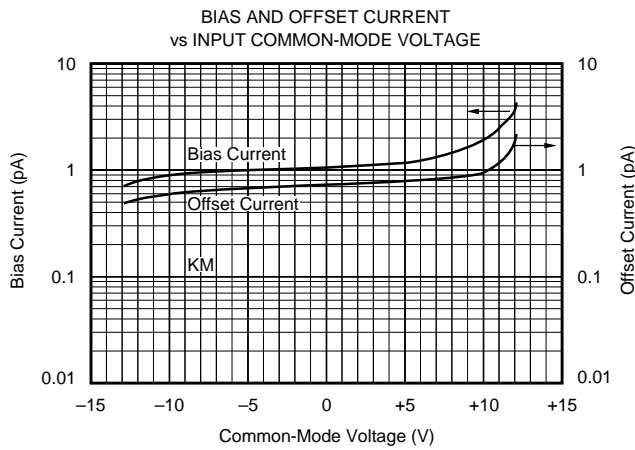
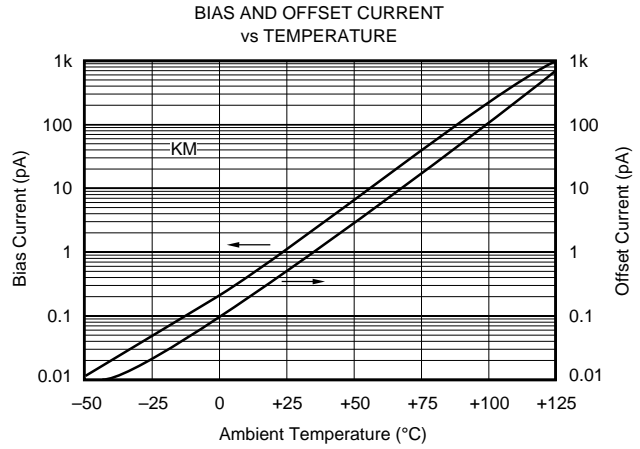
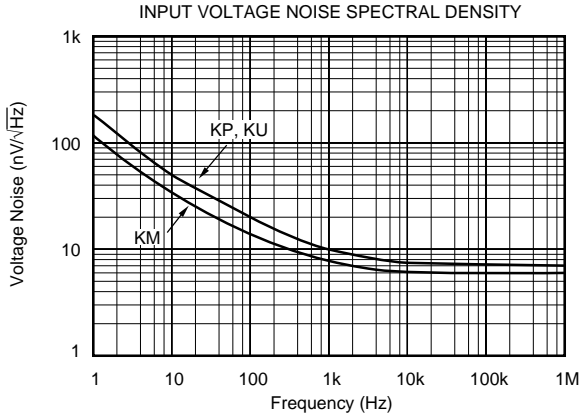

# TYPICAL PERFORMANCE CURVES (CONT)

$T_A = +25^\circ\text{C}$ ,  $V_{CC} = \pm 15\text{VDC}$  unless otherwise noted.

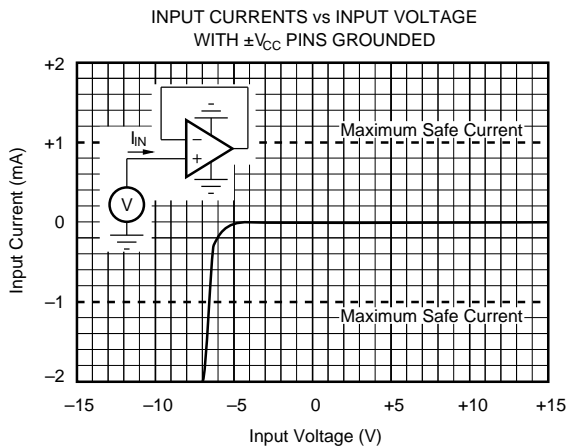
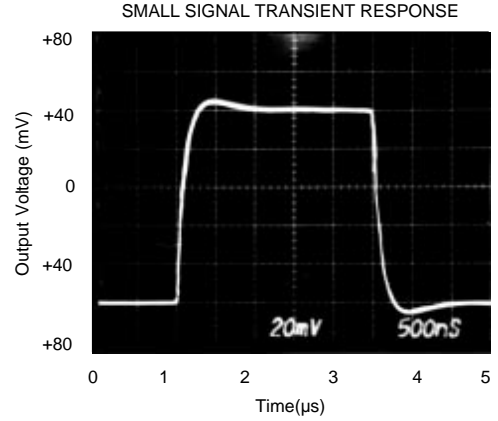
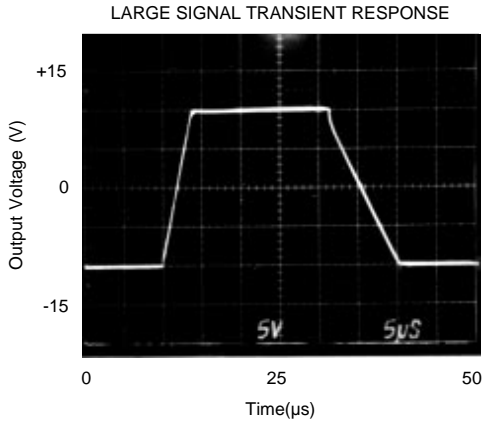

## APPLICATIONS INFORMATION

### OFFSET VOLTAGE ADJUSTMENT

The OPA121 offset voltage is laser-trimmed and will require no further trim for most applications. As with most amplifiers, externally trimming the remaining offset can change drift performance by about  $0.3\mu\text{V}/^\circ\text{C}$  for each  $100\mu\text{V}$  of adjusted offset. Note that the trim (Figure 1) is similar to operational amplifiers such as 741 and AD547. The OPA121 can replace most BIFET amplifiers by leaving the external null circuit unconnected.

### INPUT PROTECTION

Conventional monolithic FET operational amplifiers require external current-limiting resistors to protect their inputs against destructive currents that can flow when input FET gate-to-substrate isolation diodes are forward-biased. Most BIFET amplifiers can be destroyed by the loss of  $-V_{CC}$ .

Unlike BIFET amplifiers, the *Difet* OPA121 requires input current limiting resistors only if its input voltage is greater

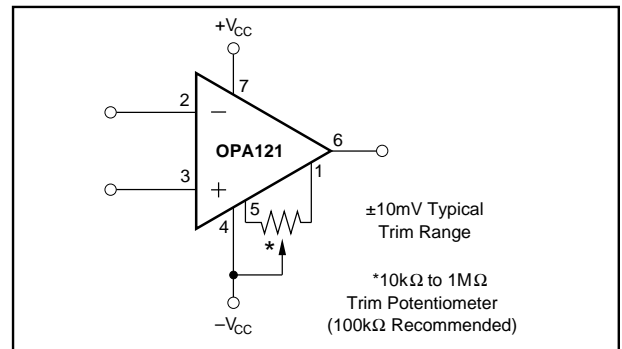

FIGURE 1. Offset Voltage Trim.

than  $6\text{V}$  more negative than  $-V_{CC}$ . A  $10\text{k}\Omega$  series resistor will limit input current to a safe level with up to  $\pm 15\text{V}$  input levels even if both supply voltages are lost.

Static damage can cause subtle changes in amplifier input characteristics without necessarily destroying the device. In precision operational amplifiers (both bipolar and FET types),

this may cause a noticeable degradation of offset voltage and drift.

Static protection is recommended when handling any precision IC operational amplifier.

### GUARDING AND SHIELDING

As in any situation where high impedances are involved, careful shielding is required to reduce “hum” pickup in input leads. If large feedback resistors are used, they should also be shielded along with the external input circuitry.

Leakage currents across printed circuit boards can easily exceed the bias current of the OPA121. To avoid leakage problems, it is recommended that the signal input lead of the OPA121 be wired to a Teflon™ standoff. If the OPA121 is to be soldered directly into a printed circuit board, utmost care must be used in planning the board layout. A “guard” pattern should completely surround the high-impedance input leads and should be connected to a low-impedance point which is at the signal input potential.

The amplifier case should be connected to any input shield or guard via pin 8. This insures that the amplifier itself is fully surrounded by guard potential, minimizing both leakage and noise pickup (see Figure #2).

If guarding is not required, pin 8 (case) should be connected to ground.

### BIAS CURRENT CHANGE VERSUS COMMON-MODE VOLTAGE

The input bias currents of most popular BIFET operational amplifiers are affected by common-mode voltage (Figure 3). Higher input FET gate-to-drain voltage causes leakage and ionization (bias) currents to increase. Due to its cascode input stage, the extremely-low bias current of the OPA121 is not compromised by common-mode voltage.

Teflon™ E.I. du Pont de Nemours & Co.

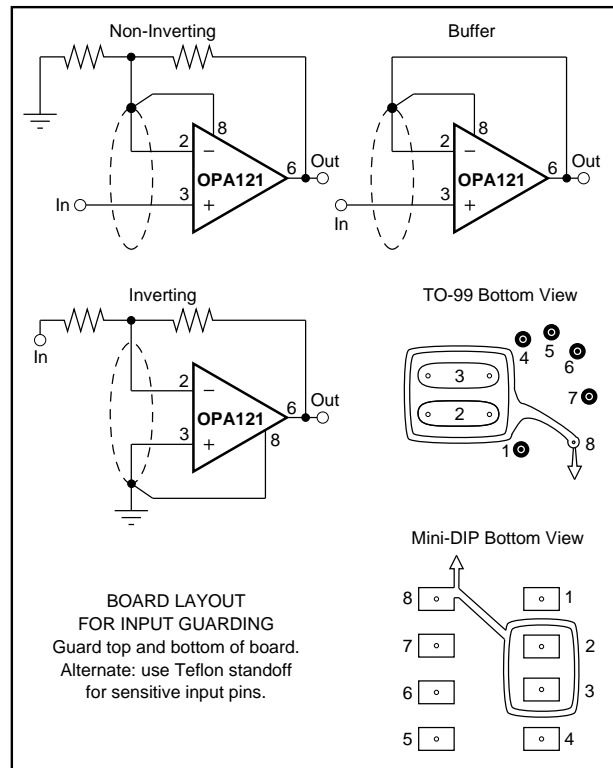

FIGURE 2. Connection of Input Guard.

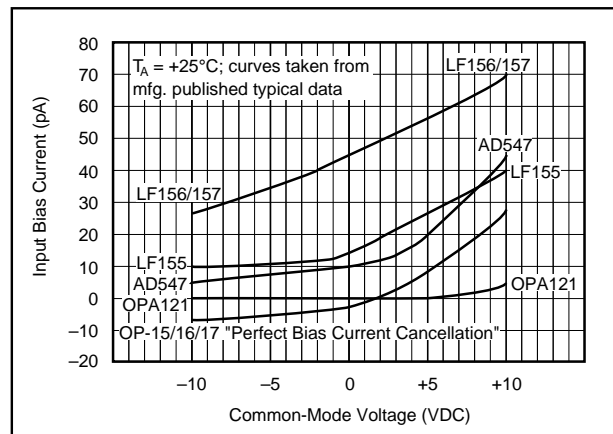

FIGURE 3. Input Bias Current vs Common-Mode Voltage.