



Product Bulletin OPB715  
June 1998

# Photologic<sup>®</sup> Reflective Object Sensor

## Types OPB715, OPB716, OPB717, OPB718



### Features

- Focused for maximum sensitivity
- 0.5" (12.7mm) sensing distance
- Panel mount
- Choice of output configurations
- 18" minimum wire length

### Description

The OPB715 series reflective assembly consists of a GaAlAs LED and a Photologic<sup>®</sup> sensor enclosed in an IR transmissive housing. The sensor is characterized to detect paper at 0.5" (12.7 mm). However, the OPB715 has a wide operating distance range and is capable of detecting reflective objects at longer distances. Even low reflectance materials can be detected at shorter distances.

The sensor's panel-mount plastic housing shields stray light and is terminated with 18" wire leads. The output can be specified as either TTL totem-pole or TLL open-collector in buffer or inverter polarity. The LED is current limited internally for design convenience.

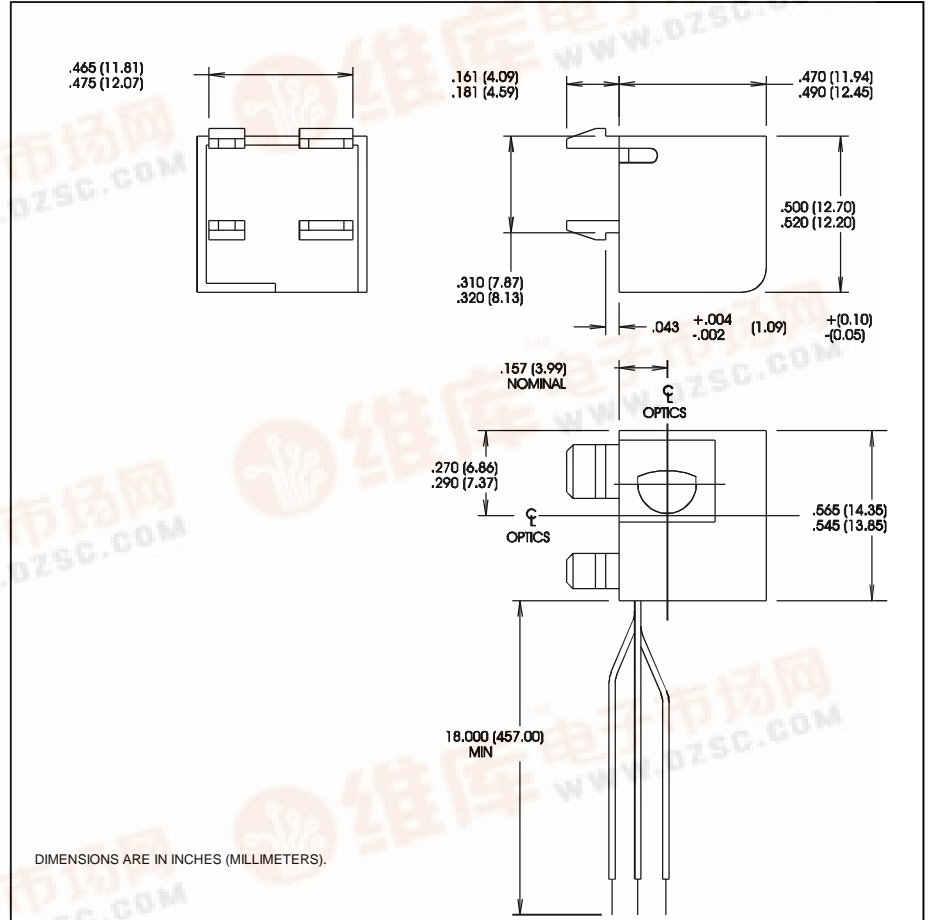

### Absolute Maximum Ratings (T<sub>A</sub> = 25° C unless otherwise noted)

Supply Voltage, V <sub>CC</sub> (not to exceed 2 sec.)	10 V
Storage Temperature Range	-40° C to +85° C
Operating Temperature Range	-40° C to +85° C
Power Dissipation	300 mW <sup>(1)</sup>
Output Voltage (Open-Collector only)	35 V

#### Notes:

- (1) Derate linearly at 5.00 mW/°C above 25° C.
- (2) Terminating wire is 7 strand, 26 AWG, UL 1429.
- (3) Tested at d = 0.5" (12.7 mm) from a 90% diffuse, white test surface.  
Reference: Eastman Kodak Catalog #1257795.
- (4) No reflective surface.



# Types OPB715, OPB716, OPB717, OPB718

Electrical Characteristics ( $T_A = -40^\circ\text{C}$  to  $+85^\circ\text{C}$  unless otherwise specified)

SYMBOL	PARAMETER	MIN	TYP	MAX	UNITS	TEST CONDITIONS
$V_{CC}$	<b>Operating D.C. Supply Voltage</b>	4.75		5.25	V	
$I_{CCL}$	<b>Low Level Supply Current:</b> OPB715: Buffered Totem-Pole Output OPB716: Buffered Open-Collector Output			50	mA	$V_{CC} = 5.25\text{ V}$ , Output Open
	OPB717: Inverted Totem-Pole Output OPB718: Inverted Open-Collector Output			50	mA	$V_{CC} = 5.25\text{ V}$ , Output Open
$I_{CCH}$	<b>High Level Supply Current:</b> OPB715: Buffered Totem-Pole Output OPB716: Buffered Open-Collector Output			50	mA	$V_{CC} = 5.25\text{ V}$ , Output Open
	OPB717: Inverted Totem-Pole Output OPB718: Inverted Open-Collector Output			50	mA	$V_{CC} = 5.25\text{ V}$ , Output Open
$I_{OH}$	<b>High Level Output Current:</b> OPB716: Buffered Open-Collector Output OPB718: Inverted Open-Collector Output			100 100	$\mu\text{A}$ $\mu\text{A}$	$V_{CC} = 5\text{ V}$ , $V_{OH} = 5\text{ V}^{(3)}$ $V_{CC} = 5\text{ V}$ , $V_{OH} = 5\text{ V}^{(4)}$
	<b>Short Circuit Output Current:</b> OPB715: Buffered Totem-Pole Output OPB717: Inverted Totem-Pole Output					
$V_{OL}$	<b>Low Level Output Voltage:</b> OPB715: Buffered Totem-Pole Output OPB716: Buffered Open-Collector Output			0.4	V	$V_{CC} = 5\text{ V}$ , $I_{OL} = 12.8\text{ mA}^{(4)}$
	OPB717: Inverted Totem-Pole Output OPB718: Inverted Open-Collector Output			0.4	V	$V_{CC} = 5\text{ V}$ , $I_{OL} = 12.8\text{ mA}^{(3)}$

OPB715: Totem-Pole Buffer Output

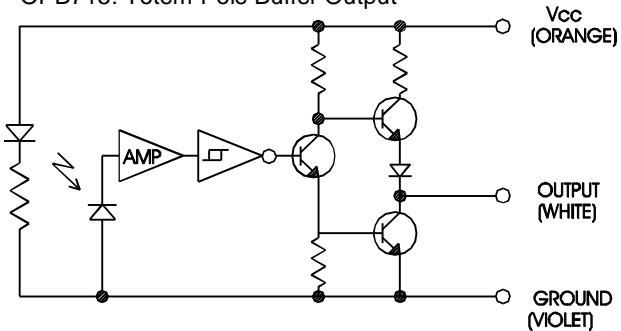

OPB716: Open-Collector Buffer Output

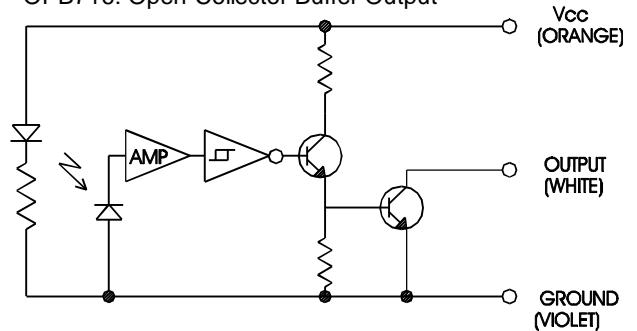

OPB717: Totem-Pole Inverter Output

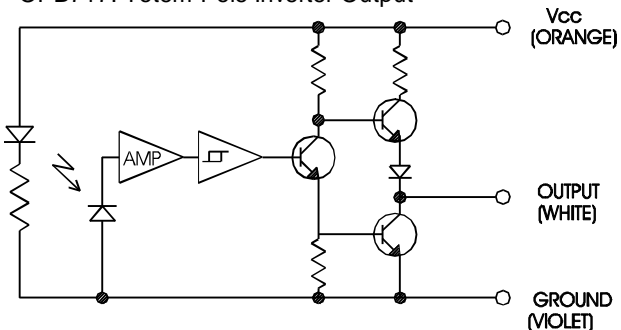

OPB718: Open-Collector Inverter Output

