

Product Bulletin OPB740
June 1996

Reflective Object Sensors

Types OPB740, OPB741, OPB742, OPB743, OPB744

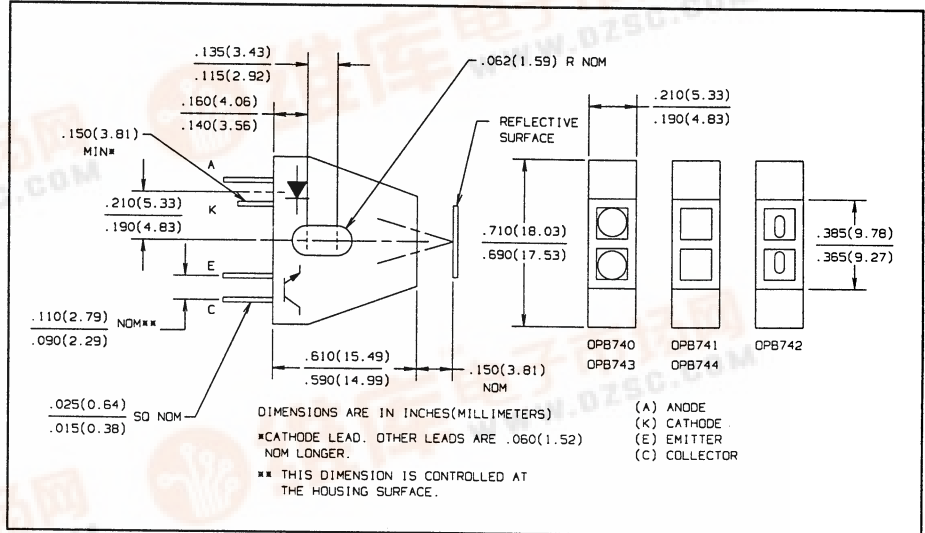
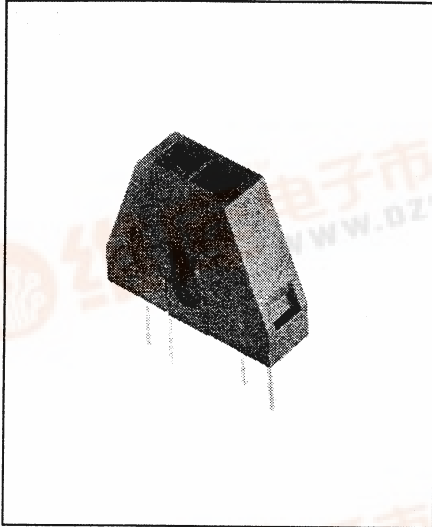

Features

- Focused for maximum sensitivity
- Phototransistor output
- PC board mounting

Description

The OPB740 through OPB744 reflective object sensors each consist of an infrared emitting diode and an NPN silicon phototransistor mounted side by side on converging optical axes in a black plastic housing. Various options include choice of no windows, blue polysulfone windows for dust protection or opaque windows with offset openings for improved resolution. Available with wires as OPB740W/OPB744W series.

The phototransistor responds to radiation from the emitter only when a reflective object passes within its field of view.

Absolute Maximum Ratings (TA = 25° C unless otherwise noted)

Storage and Operating Temperature Range -40° C to +85° C
Lead Soldering Temperature [1/16 inch (1.6 mm) from case for 5 sec. with soldering iron]. 240° C⁽¹⁾

Input Diode

Continuous Forward Current 40 mA
Reverse Voltage 2.0 V
Power Dissipation 100 mW⁽²⁾

Output Phototransistor

Collector-Emitter Voltage 30 V
Emitter-Collector Voltage 5.0 V
Power Dissipation 100 mW⁽²⁾

Notes:

- (1) RMA flux is recommended. Duration can be extended to 10 sec. max. when flow soldering.
- (2) Derate Linearly 1.67 mW/° C above 25° C.
- (3) d is distance from the assembly face to the reflective surface.
- (4) Reflective surface is Eastman Kodak neutral white test card with 90% diffuse reflectance as a reflecting surface. Reference: Eastman Kodak, Catalog #1257795.
- (5) Lower curve is based on calculated worst case condition rather than the conventional -2σ limit.
- (6) Crosstalk is the photocurrent measured with current to the input diode & no reflecting surface.
- (7) All parameters tested using pulse technique.

DESCRIPTION

OPB740	No windows
OPB741	Blue windows
OPB742	Offset windows
OPB743	No windows
OPB744	Blue windows

Types OPB740, OPB741, OPB742, OPB743, OPB744

Electrical Characteristics ($T_A = 25^\circ\text{C}$ unless otherwise noted)

SYMBOL	PARAMETER	MIN	MAX	UNITS	TEST CONDITIONS	
Input Diode						
V_F	Forward Voltage		1.70	V	$I_F = 40\text{ mA}$	
I_R	Reverse Current		100	μA	$V_R = 2.0\text{ V}$	
Output Phototransistor						
$V_{(BR)CEO}$	Collector-Emitter Breakdown Voltage	30		V	$I_C = 100\ \mu\text{A}$	
$V_{(BR)ECO}$	Emitter-Collector Breakdown Voltage	5.0		V	$I_E = 100\ \mu\text{A}$	
I_{CEO}	Collector Dark Current		100	nA	$V_{CE} = 10\text{ V}, I_F = 0, E_e = 0$	
Combined						
$I_{C(ON)}^{(3)(4)}$	On-State Collector Current	OPB740/OPB741	50	μA	$V_{CE} = 5\text{ V}, I_F = 40\text{ mA}, d = 0.15''$	
		OPB742	10	μA	$V_{CE} = 5\text{ V}, I_F = 40\text{ mA}, d = 0.15''$	
		OPB743/OPB744	200	μA	$V_{CE} = 5\text{ V}, I_F = 40\text{ mA}, d = 0.15''$	
$I_{CX}^{(6)}$	Crosstalk	OPB740/OPB741		10	μA	$V_{CE} = 5\text{ V}, I_F = 40\text{ mA}$
		OPB742		100	nA	$V_{CE} = 5\text{ V}, I_F = 40\text{ mA}$
		OPB743/OPB744		20	μA	$V_{CE} = 5\text{ V}, I_F = 40\text{ mA}$

Typical Performance Curves

