

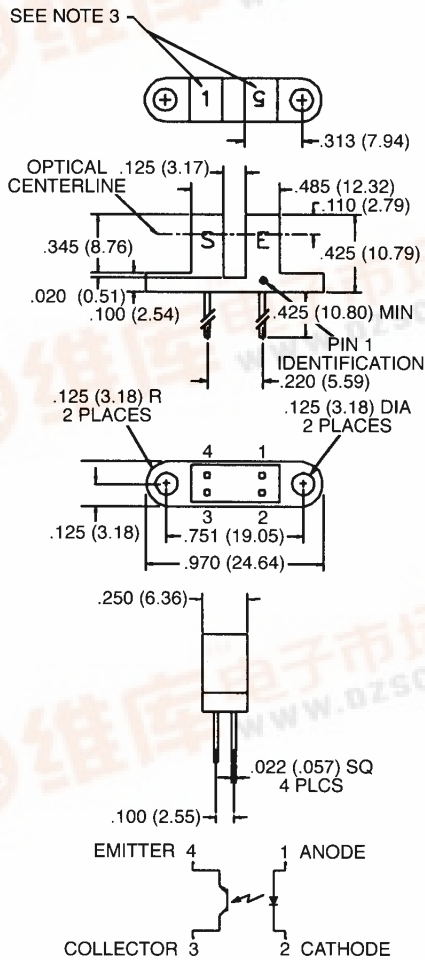

SLOTTED OPTICAL SWITCH

OPB865T11/OPB865T51/OPB865T55

PACKAGE DIMENSIONS



ST2164

NOTES:

1. DIMENSIONS ARE IN INCHES (mm).
2. TOLERANCE IS $\pm .010$ (.25) UNLESS OTHERWISE SPECIFIED.
3. NUMBER INDICATES APERTURE SIZE. (5 = .050", 1 = .010")

APERTURE OPTIONS:

	LED	PHOTOTRANSISTOR
OPB865T11	.010	.010
OPB865T51	.050	.010
OPB865T55	.050	.050

DESCRIPTION

The OPB865T series of switches is designed to allow the user maximum flexibility in applications. Each switch consists of an infrared emitting diode facing an NPN phototransistor across a .125" (3.18 mm) gap. A unique housing design provides a smooth external surface to prevent dust build-up while molded internal apertures give precise positioning and also provide protection from ambient light interference.

FEATURES

- Fully enclosed design allows dust and ambient light protection.
- Lead spacing at .220".
- .050" and .010" aperture options.
- PCB mountable.



SLOTTED OPTICAL SWITCH

ABSOLUTE MAXIMUM RATINGS ($T_A = 25^\circ\text{C}$ Unless Otherwise Specified)	
Storage Temperature	-40°C to $+85^\circ\text{C}$
Operating Temperature	-40°C to $+85^\circ\text{C}$
Soldering:	
Lead Temperature (Iron)	240°C for 5 sec. ^(2,3,4)
Lead Temperature (Flow)	260°C for 10 sec. ^(2,3)
INPUT DIODE	
Continuous Forward Current	50 mA
Reverse Voltage	5.0 Volts
Power Dissipation	100 mW ⁽¹⁾
OUTPUT TRANSISTOR	
Collector-Emitter Voltage	30.0 Volts
Emitter-Collector Voltage	5.0 Volts
Power Dissipation	100 mW ⁽¹⁾

ELECTRICAL CHARACTERISTICS ($T_A = 25^\circ\text{C}$ Unless Otherwise Specified)					
PARAMETER	SYMBOL	MIN.	MAX.	UNITS	TEST CONDITIONS
INPUT DIODE					
Forward Voltage	V_F	—	1.70	V	$I_F = 20\text{ mA}$
Reverse Leakage Current	I_R	—	100	μA	$V_R = 2.0\text{ V}$
OUTPUT TRANSISTOR					
Emitter-Collector Breakdown	BV_{ECO}	5	—	V	$I_E = 100\ \mu\text{A}$, $E_e = 0$
Collector-Emitter Breakdown	BV_{CEO}	30	—	V	$I_C = 1.0\text{ mA}$, $E_e = 0$
Collector-Emitter Leakage	I_{CEO}	—	100	nA	$V_{CE} = 10.0\text{ V}$, $E_e = 0$
COUPLED					
On-State Collector Current					
OPB865T11	$I_{C(ON)}$	500	—	μA	$I_F = 20\text{ mA}$, $V_{CE} = 5\text{ V}$
OPB865T51	$I_{C(ON)}$	500	—	μA	$I_F = 20\text{ mA}$, $V_{CE} = 5\text{ V}$
OPB865T55	$I_{C(ON)}$	500	—	μA	$I_F = 20\text{ mA}$, $V_{CE} = 5\text{ V}$
Saturation Voltage	$V_{CE(SAT)}$	—	0.40	V	$I_F = 20\text{ mA}$, $I_C = 400\ \mu\text{A}$

NOTES
1. Derate power dissipation linearly 1.67 mW/ $^\circ\text{C}$ above 25°C .
2. RMA flux is recommended.
3. Methanol or Isopropyl alcohols are recommended as cleaning agents.
4. Soldering iron tip $\frac{1}{16}$ " (1.6 mm) from housing.