



# Wideband, 40 dB Isolation at 1 GHz, CMOS 1.65 V to 2.75 V, SPST Switches

## ADG901/ADG902

### FEATURES

- Wideband Switch: -3 dB @ 4.5 GHz
- Absorptive/Reflective Switches
- High Off Isolation (40 dB @ 1 GHz)
- Low Insertion Loss (0.8 dB @ 1 GHz)
- Single 1.65 V to 2.75 V Power Supply
- CMOS/LVTTL Control Logic
- 8-Lead MSOP and Tiny 3 mm × 3 mm LFCSP Packages
- Low Power Consumption (<1 μA)

### APPLICATIONS

- Wireless Communications
- General-Purpose RF Switching
- Dual-Band Applications
- High Speed Filter Selection
- Digital Transceiver Front End Switch
- IF Switching
- Tuner Modules
- Antenna Diversity Switching

### GENERAL DESCRIPTION

The ADG901/ADG902 are wideband switches that use a CMOS process to provide high isolation and low insertion loss to 1 GHz. The ADG901 is an absorptive (matched) switch with 50 Ω terminated shunt legs, while the ADG902 is a reflective switch. These devices are designed such that the isolation is high over the dc to 1 GHz frequency range. They have on-board CMOS control logic, thus eliminating the need for external controlling circuitry. The control inputs are both CMOS and

### FUNCTIONAL BLOCK DIAGRAMS

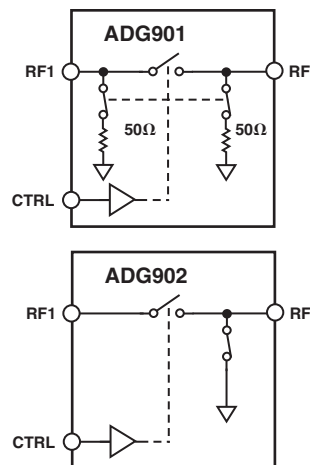

LVTTL compatible. The low power consumption of these CMOS devices makes them ideally suited to wireless applications and general-purpose high frequency switching.

### PRODUCT HIGHLIGHTS

1. -40 dB Off Isolation @ 1 GHz
2. 0.8 dB Insertion Loss @ 1 GHz
3. Tiny 8-Lead MSOP/LFCSP Packages

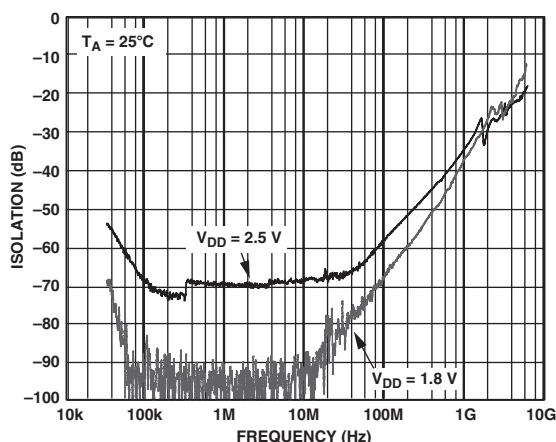

Figure 1. Off Isolation vs. Frequency

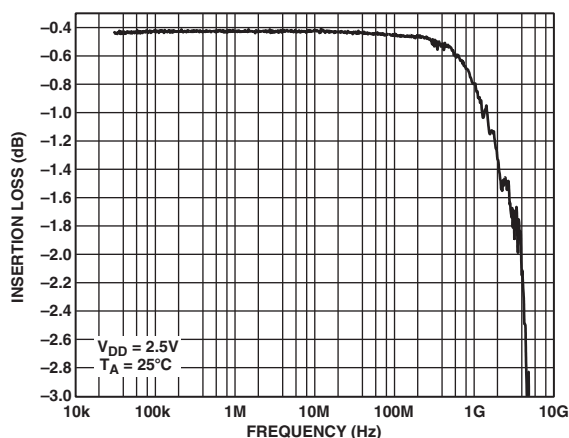

Figure 2. Insertion Loss vs. Frequency

REV. A

Information furnished by Analog Devices is believed to be accurate and reliable. However, no responsibility is assumed by Analog Devices for its use, nor for any infringements of patents or other rights of third parties that may result from its use. No license is granted by implication or otherwise under any patent or patent rights of Analog Devices. Trademarks and registered trademarks are the property of their respective owners.

# ADG901/ADG902—SPECIFICATIONS<sup>1</sup> ( $V_{DD} = 1.65\text{ V}$ to $2.75\text{ V}$ , $GND = 0\text{ V}$ , input power = $0\text{ dBm}$ , all specifications $T_{MIN}$ to $T_{MAX}$ , unless otherwise noted.)

Parameter	Symbol	Conditions	B Version			Unit
			Min	Typ <sup>2</sup>	Max	
<b>AC ELECTRICAL CHARACTERISTICS</b>						
Operating Frequency <sup>3</sup>			DC		2.5	GHz
-3 dB Frequency <sup>4</sup>					4.5	GHz
Input Power <sup>4</sup>		0 V dc Bias			7	dBm
		+0.5 V dc Bias			16	dBm
Insertion Loss	$S_{21}$ , $S_{12}$	DC to 100 MHz; $V_{DD} = 2.5\text{ V} \pm 10\%$		0.4	0.7	dB
		500 MHz; $V_{DD} = 2.5\text{ V} \pm 10\%$		0.5	0.8	dB
		1000 MHz; $V_{DD} = 2.5\text{ V} \pm 10\%$		0.8	1.25	dB
Isolation—RF1 to RF2 (CP Package)	$S_{21}$ , $S_{12}$	100 MHz	60	61		dB
		500 MHz	43	45		dB
		1000 MHz	34	40		dB
Isolation—RF1 to RF2 (RM Package)	$S_{21}$ , $S_{12}$	100 MHz	51	60		dB
		500 MHz	37.5	47		dB
		1000 MHz	31	37		dB
Return Loss (On Channel) <sup>4</sup>	$S_{11}$ , $S_{22}$	DC to 100 MHz	20	28		dB
		500 MHz	23	29		dB
		1000 MHz	25	28		dB
Return Loss (Off Channel) <sup>4</sup>	$S_{11}$ , $S_{22}$	DC to 100 MHz	18	23		dB
		500 MHz	17	21		dB
		1000 MHz	15	19		dB
On Switching Time <sup>4</sup>	$t_{ON}$	50% CTRL to 90% RF		3.6	6	ns
Off Switching Time <sup>4</sup>	$t_{OFF}$	50% CTRL to 10% RF		5.8	9.5	ns
Rise Time <sup>4</sup>	$t_{RISE}$	10% to 90% RF		3.1	5.5	ns
Fall Time <sup>4</sup>	$t_{FALL}$	90% to 10% RF		6.0	8.5	ns
1 dB Compression <sup>4</sup>	$P_{-1\text{ dB}}$	1000 MHz			17	dBm
Third Order Intermodulation Intercept	$IP_3$	900 MHz/901 MHz, 4 dBm	30	36		dBm
Video Feedthrough <sup>5</sup>					2.5	mV p-p
<b>DC ELECTRICAL CHARACTERISTICS</b>						
Input High Voltage	$V_{INH}$	$V_{DD} = 2.25\text{ V}$ to $2.75\text{ V}$	1.7			V
	$V_{INH}$	$V_{DD} = 1.65\text{ V}$ to $1.95\text{ V}$	0.65 $V_{CC}$			V
Input Low Voltage	$V_{INL}$	$V_{DD} = 2.25\text{ V}$ to $2.75\text{ V}$			0.7	V
	$V_{INL}$	$V_{DD} = 1.65\text{ V}$ to $1.95\text{ V}$			0.35 $V_{CC}$	V
Input Leakage Current	$I_I$	$0 \leq V_{IN} \leq 2.75\text{ V}$		$\pm 0.1$	$\pm 1$	$\mu\text{A}$
<b>CAPACITANCE<sup>4</sup></b>						
RF1/RF2, RF Port On Capacitance	$C_{RF\text{ ON}}$	$f = 1\text{ MHz}$		1.2		pF
CTRL Input Capacitance	$C_{CTRL}$	$f = 1\text{ MHz}$		2.1		pF
<b>POWER REQUIREMENTS</b>						
$V_{DD}$			1.65		2.75	V
Quiescent Power Supply Current	$I_{DD}$	Digital inputs = 0 V or $V_{DD}$		0.1	1	$\mu\text{A}$

## NOTES

<sup>1</sup>Temperature range B Version:  $-40^\circ\text{C}$  to  $+85^\circ\text{C}$ .

<sup>2</sup>Typical values are at  $V_{DD} = 2.5\text{ V}$  and  $25^\circ\text{C}$ , unless otherwise stated.

<sup>3</sup>Point at which insertion loss degrades by 1 dB.

<sup>4</sup>Guaranteed by design, not subject to production test.

<sup>5</sup>The dc transience at the output of any port of the switch when the control voltage is switched from high to low or low to high in a  $50\ \Omega$  test setup, measured with 1 ns rise time pulses and 500 MHz bandwidth.

Specifications subject to change without notice.

## ABSOLUTE MAXIMUM RATINGS<sup>1</sup>

(T<sub>A</sub> = 25°C, unless otherwise noted.)

V <sub>DD</sub> to GND	-0.5 V to +4 V
Inputs to GND	-0.5 V to V <sub>DD</sub> + 0.3 V <sup>2</sup>
Continuous Current	30 mA
Input Power	18 dBm
Operating Temperature Range	
Industrial (B Version)	-40°C to +85°C
Storage Temperature Range	-65°C to +150°C
Junction Temperature	150°C
MSOP Package	
θ <sub>JA</sub> Thermal Impedance	206°C/W

## LFCSP Package

θ <sub>JA</sub> Thermal Impedance (2-layer board)	84°C/W
θ <sub>JA</sub> Thermal Impedance (4-layer board)	48°C/W
Lead Temperature, Soldering (10 sec)	300°C
IR Reflow, Peak Temperature (<20 sec)	235°C
ESD	1 kV

### NOTES

<sup>1</sup> Stresses above those listed under Absolute Maximum Ratings may cause permanent damage to the device. This is a stress rating only and functional operation of the device at these or any other conditions above those listed in the operational sections of this specification is not implied. Exposure to absolute maximum rating conditions for extended periods may affect device reliability. Only one absolute maximum rating may be applied at any one time.

<sup>2</sup> RF1/2 Off Port Inputs to Ground ..... -0.5 V to V<sub>DD</sub> - 0.5 V

## ORDERING GUIDE

Model	Temperature Range	Package Description	Package Option	Branding
ADG901BRM	-40°C to +85°C	Mini Small Outline Package (MSOP)	RM-8	W6B
ADG901BRM-500RL7	-40°C to +85°C	Mini Small Outline Package (MSOP)	RM-8	W6B
ADG901BRM-REEL7	-40°C to +85°C	Mini Small Outline Package (MSOP)	RM-8	W6B
ADG901BCP-500RL7	-40°C to +85°C	Lead Frame Chip Scale Package (LFCSP)	CP-8	W6B
ADG901BCP-REEL7	-40°C to +85°C	Lead Frame Chip Scale Package (LFCSP)	CP-8	W6B
ADG902BRM	-40°C to +85°C	Mini Small Outline Package (MSOP)	RM-8	W7B
ADG902BRM-500RL7	-40°C to +85°C	Mini Small Outline Package (MSOP)	RM-8	W7B
ADG902BRM-REEL7	-40°C to +85°C	Lead Frame Chip Scale Package (LFCSP)	RM-8	W7B
ADG902BCP-500RL7	-40°C to +85°C	Lead Frame Chip Scale Package (LFCSP)	CP-8	W7B
ADG902BCP-REEL7	-40°C to +85°C	Lead Frame Chip Scale Package (LFCSP)	CP-8	W7B
EVAL-ADG901EB		Evaluation Board		
EVAL-ADG902EB		Evaluation Board		

## CAUTION

ESD (electrostatic discharge) sensitive device. Electrostatic charges as high as 4000 V readily accumulate on the human body and test equipment and can discharge without detection. Although the ADG901/ADG902 features proprietary ESD protection circuitry, permanent damage may occur on devices subjected to high energy electrostatic discharges. Therefore, proper ESD precautions are recommended to avoid performance degradation or loss of functionality.



### PIN CONFIGURATION

8-Lead MSOP (RM-8)  
8-Lead 3 mm × 3 mm LFCSP (CP-8)

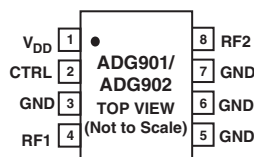

Table I. Truth Table

CTRL	Signal Path
0	RF1 isolated from RF2
1	RF1 to RF2

### PIN FUNCTION DESCRIPTIONS

Pin No.	Mnemonic	Function
1	V <sub>DD</sub>	Power Supply Input. These parts can be operated from 1.65 V to 2.75 V; V <sub>DD</sub> should be decoupled to GND.
2	CTRL	CMOS or TTL Logic Level. 0 → RF1 Isolated from RF2 1 → RF1 to RF2
3, 5, 6, 7	GND	Ground Reference Point for All Circuitry on the Part.
4	RF1	RF1 Port.
8	RF2	RF2 Port.

## TERMINOLOGY

Parameter	Description
V <sub>DD</sub>	Most positive power supply potential.
I <sub>DD</sub>	Positive supply current.
GND	Ground (0 V) reference.
CTRL	Logic control input.
V <sub>INL</sub>	Maximum input voltage for Logic 0.
V <sub>INH</sub>	Minimum input voltage for Logic 1.
I <sub>INL</sub> (I <sub>INH</sub> )	Input current of the digital input.
C <sub>IN</sub>	Digital input capacitance.
t <sub>ON</sub>	Delay between applying the digital control input and the output switching on.
t <sub>OFF</sub>	Delay between applying the digital control input and the output switching off.
t <sub>RISE</sub>	Rise time. Time for the RF signal to rise from 10% to 90% of the ON level.
t <sub>FALL</sub>	Fall time. Time for the RF signal to fall from 90% to 10% of the ON level.
Off Isolation	The attenuation between input and output ports of the switch when the switch control voltage is in the OFF condition.
Insertion Loss	The attenuation between input and output ports of the switch when the switch control voltage is in the ON condition.
P <sub>-1 dB</sub>	1 dB compression point. The RF input power level at which the switch insertion loss increases by 1 dB over its low level value. It is a measure of how much power the ON switch can handle before the insertion loss increases by 1 dB.
IP <sub>3</sub>	Third order intermodulation intercept. This is a measure of the power in false tones that occur when closely spaced tones are passed through a switch, whereby the nonlinearity of the switch causes these false tones to be generated.
Return Loss	The amount of reflected power relative to the incident power at a port. Large return loss indicates good matching. By measuring Return Loss the VSWR can be calculated from conversion charts. VSWR (voltage standing wave ratio) indicates degree of matching present at a switch RF port.
Video Feedthrough	Spurious signals present at the RF ports of the switch when the control voltage is switched from high to low or low to high without an RF signal present.

# Typical Performance Characteristics—ADG901/ADG902

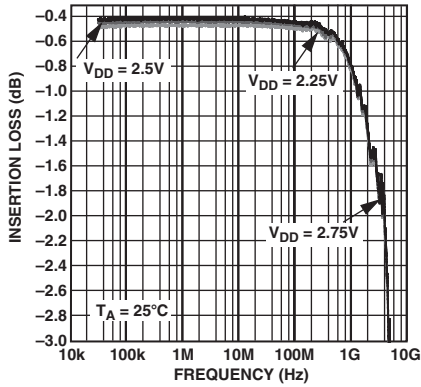

TPC 1. Insertion Loss vs. Frequency over Supplies (S12 and S21)

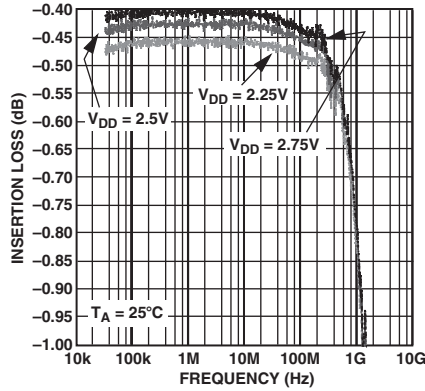

TPC 2. Insertion Loss vs. Frequency over Supplies (S12 and S21) (Zoomed TPC 1 Plot)

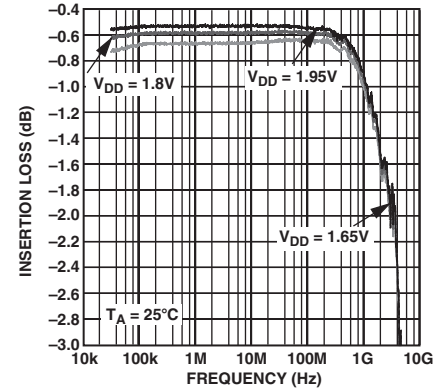

TPC 3. Insertion Loss vs. Frequency over Supplies (S12 and S21)

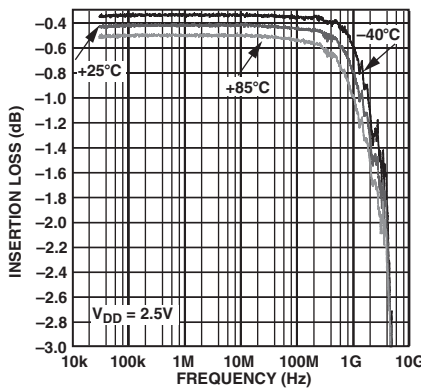

TPC 4. Insertion Loss vs. Frequency over Temperature (S12 and S21)

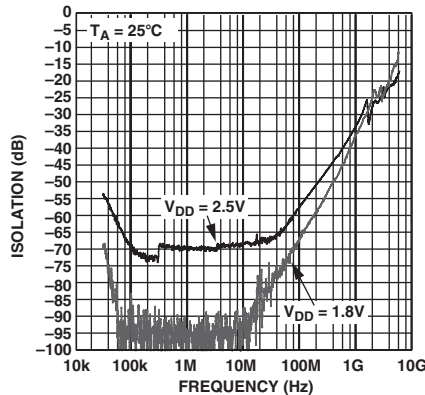

TPC 5. OFF Isolation vs. Frequency over Supplies (S12 and S21)

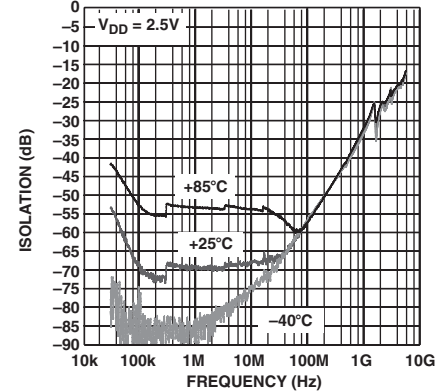

TPC 6. OFF Isolation vs. Frequency over Temperature (S12 and S21)

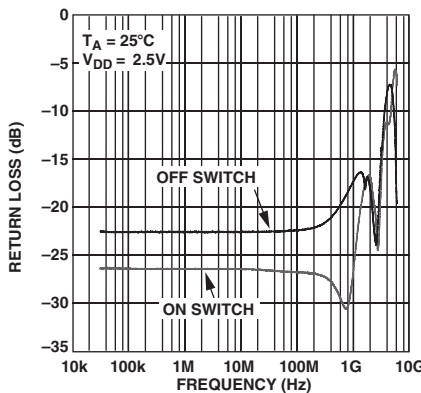

TPC 7. Return Loss vs. Frequency (S11)

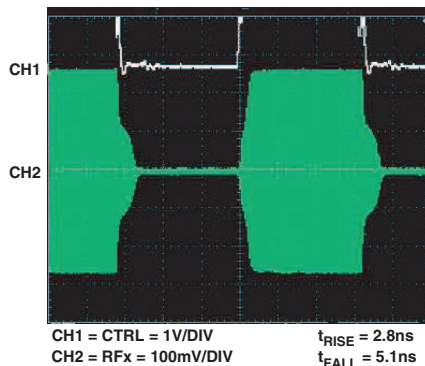

TPC 8. Switch Timing

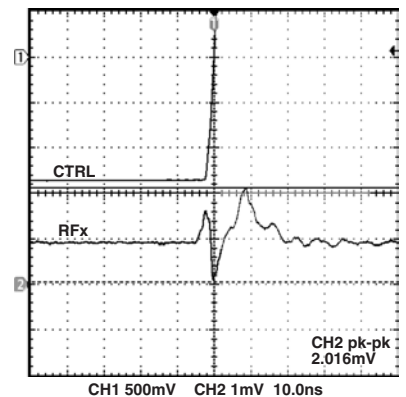

TPC 9. Video Feedthrough

# ADG901/ADG902

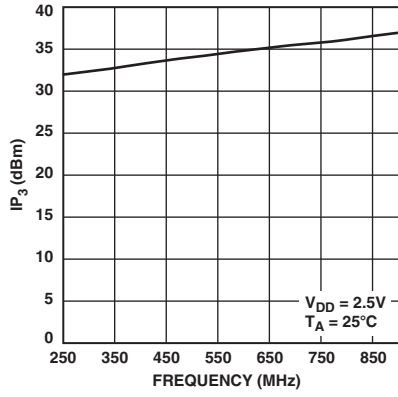

TPC 10.  $IP_3$  vs. Frequency

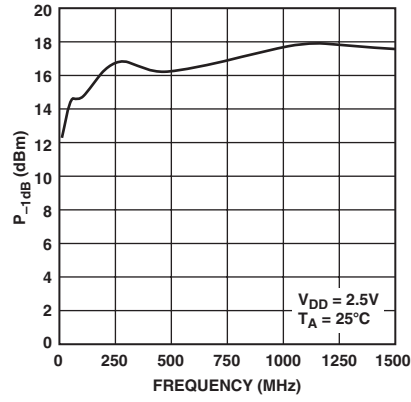

TPC 11.  $P_{-1dB}$  vs. Frequency

## Test Circuits\*

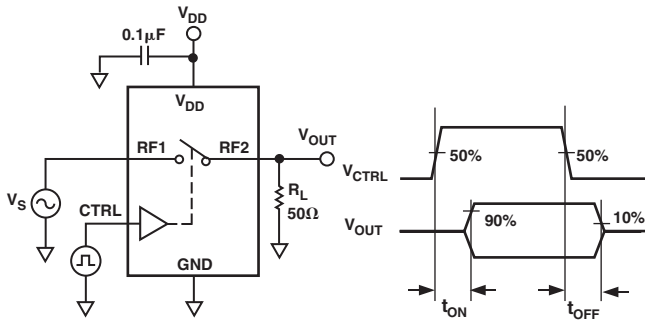

Test Circuit 1. Switching Timing:  $t_{ON}$ ,  $t_{OFF}$

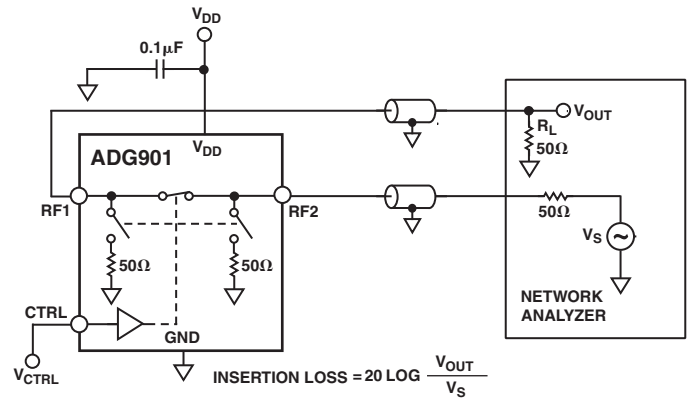

Test Circuit 4. Insertion Loss

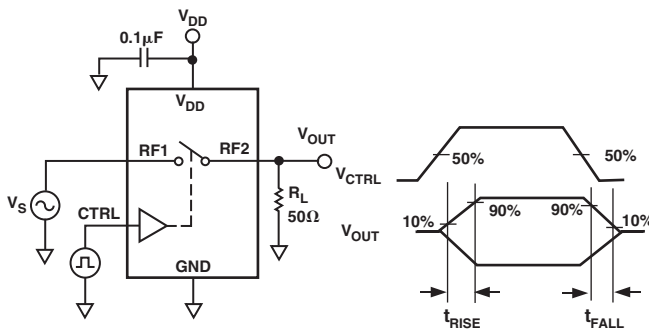

Test Circuit 2. Switch Timing:  $t_{RISE}$ ,  $t_{FALL}$

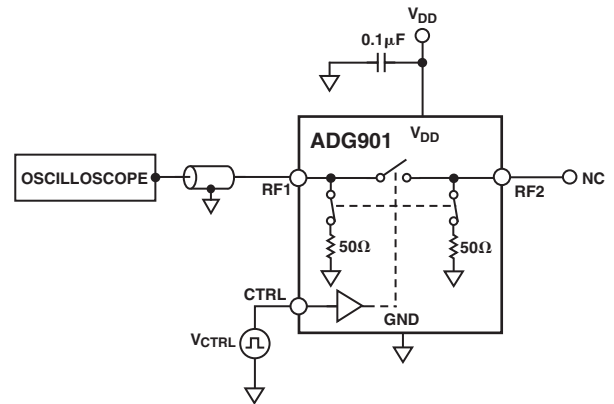

Test Circuit 5. Video Feedthrough

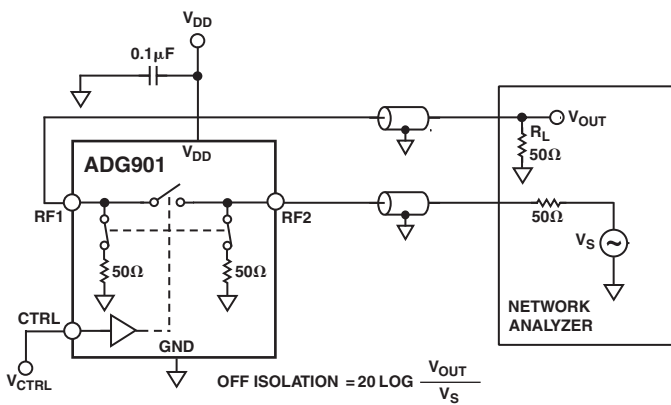

Test Circuit 3. Off Isolation

\*Similar setups for ADG902.

# ADG901/ADG902

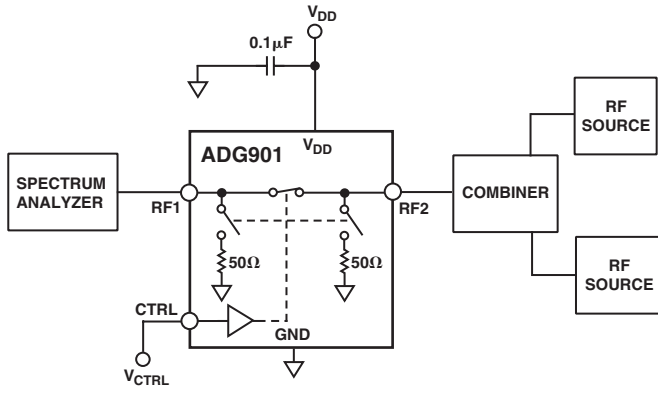

Test Circuit 6.  $IP_3$

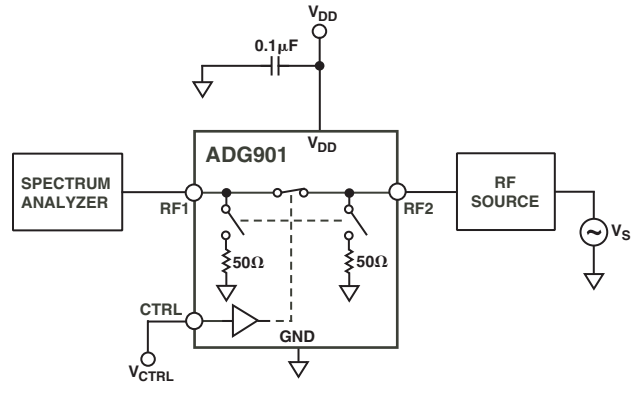

Test Circuit 7.  $P_{-1dB}$



## APPLICATIONS

The ADG901/ADG902 are ideal solutions for low power, high frequency applications. The low insertion loss, high isolation between ports, low distortion, and low current consumption of these parts make them excellent solutions for many high frequency switching applications.

Applications include switching between high frequency filters, ASK generator, and FSK generator.

### Absorptive vs. Reflective Switches

The ADG901 is an absorptive (matched) switch with 50  $\Omega$  terminated shunt legs, and the ADG902 is a reflective switch with 0  $\Omega$  terminated shunts to ground. The ADG901 absorptive switch has a good VSWR on each port, regardless of the switch mode. An absorptive switch should be used when there is a need for a good VSWR that is looking into the port but not passing the through signal to the common port. The ADG901 is therefore ideal for applications that require minimum reflections back to the RF source. It also ensures that the maximum power is transferred to the load.

The ADG902 reflective switch is suitable for applications where high off port VSWR does not matter and the switch has some other desired performance feature. It can be used in many applications, including high speed filter selection. In most cases, an absorptive switch can be used instead of a reflective switch, but not vice versa.

## ADG9xx EVALUATION BOARD

The ADG9xx evaluation board allows designers to evaluate the high performance wideband switches with a minimum of effort.

To prove that these devices meet user requirements, the user requires only a power supply and a network analyzer along with the evaluation board. An application note is available with the evaluation board and provides complete information on operating the evaluation board.

The RF1 port (see Figure 3) is connected through a 50  $\Omega$  transmission line to the top left SMA connector J1. RF2 is connected through a 50  $\Omega$  transmission line to the top SMA connector J2. J3 is connected to GND. A through transmission line connects J4 and J5 and this transmission line is used to estimate the loss of the PCB over the environmental conditions being evaluated.

The board is constructed of a 4-layer, FR4 material with a dielectric constant of 4.3 and an overall thickness of 0.062 inches. Two ground layers with grounded planes provide ground for the RF transmission lines. The transmission lines were designed using a coplanar waveguide with ground plane model using a trace width of 0.052 inches, clearance to ground plane of 0.030 inches, dielectric thickness of 0.029 inches, and a metal thickness of 0.014 inches.

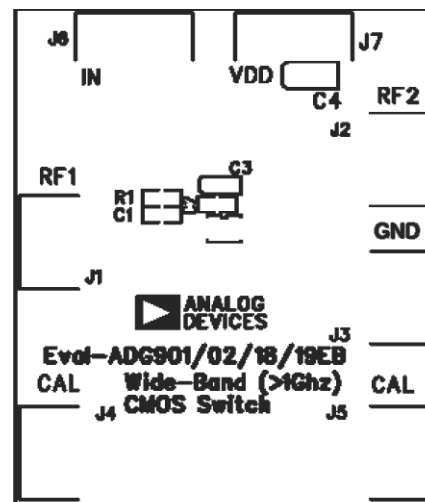
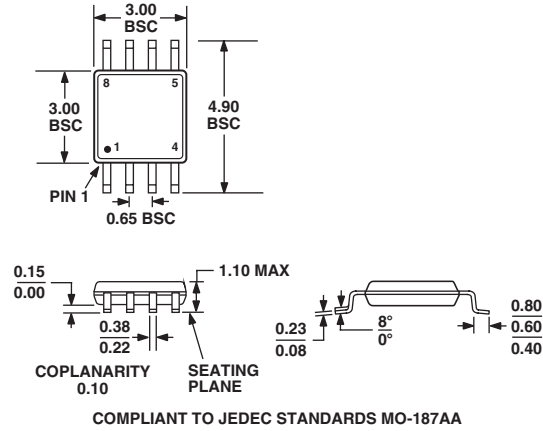

Figure 3. ADG9xx Evaluation Board Top View

OUTLINE DIMENSIONS

8-Lead Mini Small Outline Package [MSOP]  
(RM-8)

Dimensions shown in millimeters



8-Lead Lead Frame Chip Scale Package [LFCSP]  
3 mm × 3 mm Body  
(CP-8)

Dimensions shown in millimeters

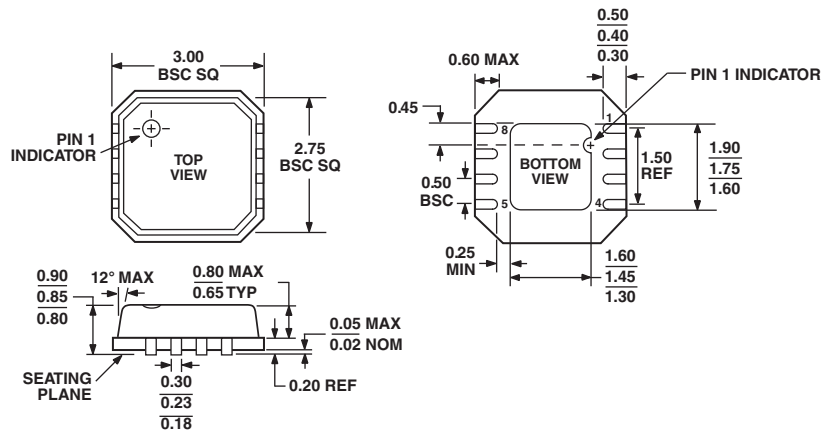

## Revision History

<b>Location</b>	<b>Page</b>
<b>10/04—Data Sheet changed from REV. 0 to REV. A.</b>	
Changes to FEATURES .....	1
Changes to PRODUCT HIGHLIGHTS .....	1
Changes to SPECIFICATIONS .....	2
Changes to ORDERING GUIDE .....	3
Change to ADG9xx EVALUATION BOARD section .....	9
Updated OUTLINE DIMENSIONS .....	10



Copyright © Each Manufacturing Company.

All Datasheets cannot be modified without permission.

This datasheet has been download from :

[www.AllDataSheet.com](http://www.AllDataSheet.com)

100% Free DataSheet Search Site.

Free Download.

No Register.

Fast Search System.

[www.AllDataSheet.com](http://www.AllDataSheet.com)