



## 8XC151SA/SB HIGH-PERFORMANCE CHMOS MICROCONTROLLER

*Commercial/Express*

- MCS<sup>®</sup> 51 Microcontroller Compatible Instruction Set
- Pin Compatible with 44-lead PLCC and 40-lead PDIP MCS 51 Sockets
- Fast Instruction Pipeline
- 16-bit Internal Code Fetch
- 8-bit, Min 2-clock External Code Fetch in Page Mode
- User-selectable Configurations:
  - External Wait States (0-3 wait states)
  - Page Mode
- 64K External Code Memory Space
- 64K External Data Memory Space
- ROM/OTPROM Options:
  - 8 Kbytes (SA), 16 Kbytes (SB)
  - or without ROM/OTPROM
- 256 Bytes On-Chip RAM
- Power Management
  - Idle Mode
  - Powerdown Mode
- 32 Programmable I/O Lines
- Seven Maskable Interrupt Sources with Four Programmable Priority Levels
- Three Flexible 16-bit Timer/counters
- Hardware Watchdog Timer
- Programmable Counter Array
  - High-speed Output
  - Compare/Capture Operation
  - Pulse Width Modulator
  - Watchdog Timer
- Programmable Serial I/O Port
  - Framing Error Detection
  - Automatic Address Recognition
- High-performance CHMOS Technology
- Static Standby to 16-MHz Operation
- Package Options (PDIP, PLCC)

---

The 8XC151SA/SB has an MCS 51 microcontroller compatible instruction set. It is available in 40-pin PDIP and 44-lead PLCC compatible with the MCS 51 microcontroller. The 8XC151SA/SB has 256 bytes of on-chip RAM and is available in 8/16 Kbytes of on-chip ROM/OTPROM or without ROM/OTPROM. A variety of new features such as programmable wait states, page mode and extended ALE can be selected using the new user-programmable configuration.

\*Other brands and names are the property of their respective owners. Information in this document is provided in connection with Intel products. Intel assumes no liability whatsoever, including infringement of any patent or copyright, for sale and use of Intel products except as provided in Intel's Terms and Conditions of Sale for such products. Intel retains the right to make changes to these specifications at any time, without notice. Microcomputer Products may have minor variations to this specification known as errata.

COPYRIGHT © INTEL CORPORATION, 1995

March 1995

Order Number: 272814-001

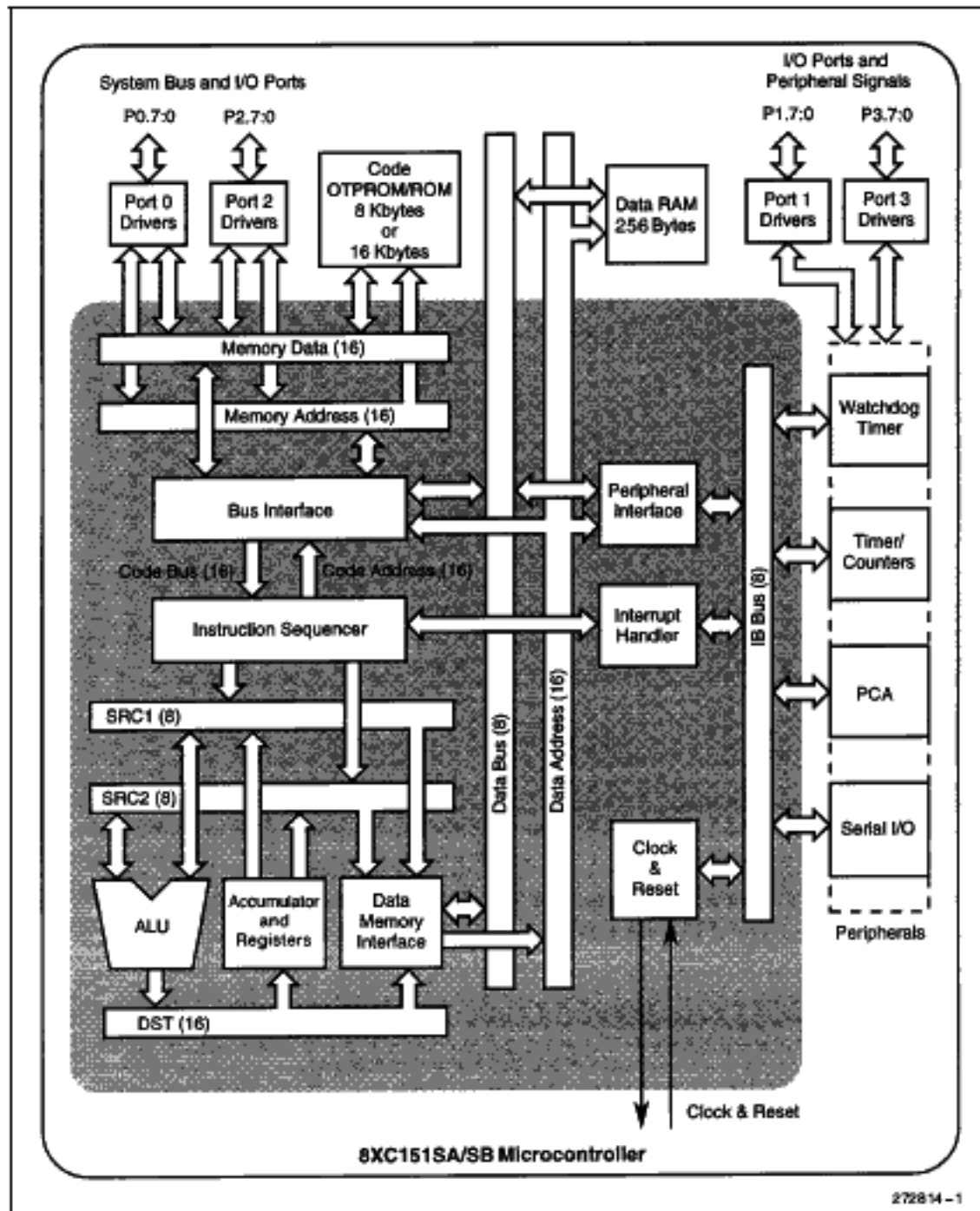

Figure 1. 8XC151SA/SB Block Diagram



## 8XC151SA/SB HIGH-PERFORMANCE CHMOS MICROCONTROLLER

### TEMPERATURE RANGE

With the commercial (standard) temperature option, the device operates over the temperature range 0°C to +70°C. The express temperature option provides -40°C to +85°C device operation.

### PROLIFERATION OPTIONS

Table 1 lists the proliferation options. See Figure 2 for the 8XC151SA/SB family nomenclature.

**Table 1. Proliferation Options**

8XC151SA/SB (0 MHz–16 MHz; 5V ± 10%)	
80C151SB	CPU-only
83C151SA	8K ROM
83C151SB	16K ROM
87C151SA	8K OTPROM
87C151SB	16K OTPROM

### PROCESS INFORMATION

This device is manufactured on a complimentary high-performance metal-oxide semiconductor (CHMOS) process. Additional process and reliability information is available in Intel's *Components Quality and Reliability Handbook* (order number 210997).

All thermal impedance data is approximate for static air conditions at 1 watt of power dissipation. Values change depending on operating conditions and application requirements. The Intel *Packaging Handbook* (order number 240800) describes Intel's thermal impedance test methodology.

**Table 2. Thermal Characteristics**

Package Type	$\theta_{JA}$	$\theta_{JC}$
44-Lead PLCC	46°C/W	16°C/W
40-Pin PDIP	45°C/W	16°C/W

### PACKAGE OPTIONS

Table 3 lists the 8XC151SA/SB packages.

**Table 3. Package Information**

Pkg.	Definition	Temperature
N	44-Lead PLCC	0°C to +70°C
P	40-Pin Plastic DIP	0°C to +70°C
TN	44-Lead PLCC	-40°C to +85°C
TP	40-Pin Plastic DIP	-40°C to +85°C

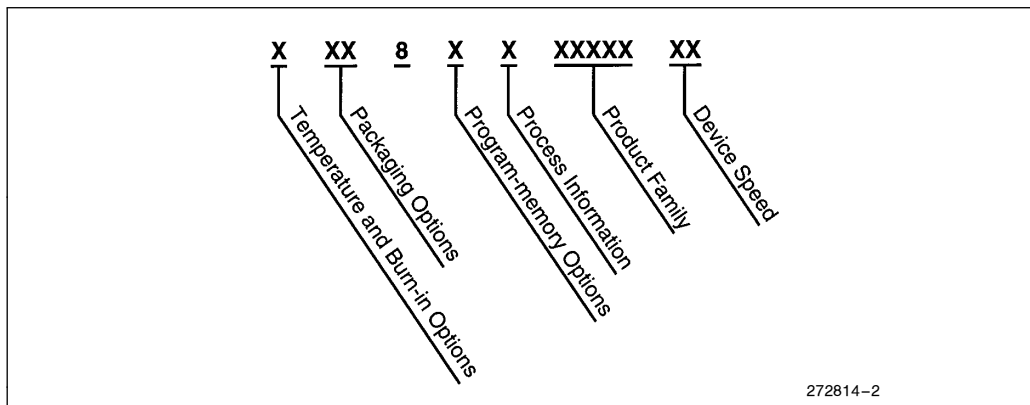

Figure 2. The 8XC151SA/SB Family Nomenclature

Table 4. Description of Product Nomenclature

Parameter	Options	Description
Temperature and Burn-in Options	no mark	Commercial operating temperature range (0°C to 70°C) with Intel standard burn-in.
	T	Express operating temperature range (– 40°C to 85°C) with Intel standard burn-in.
Packaging Options	N	44-lead Plastic Leaded Chip Carrier (PLCC)
	P	40-pin Plastic Dual In-line Package (PDIP)
Program Memory Options	0	Without ROM/OTPROM
	3	ROM
	7	User programmable OTPROM
Process Information	C	CHMOS
Product Family	151	8-bit controller architecture
Device Memory Options	SA/SB	256 bytes RAM/8/16 Kbyte ROM/OTPROM or without ROM/OTPROM
Device Speed	16	External clock frequency



### 8XC151SA/SB HIGH-PERFORMANCE CHMOS MICROCONTROLLER

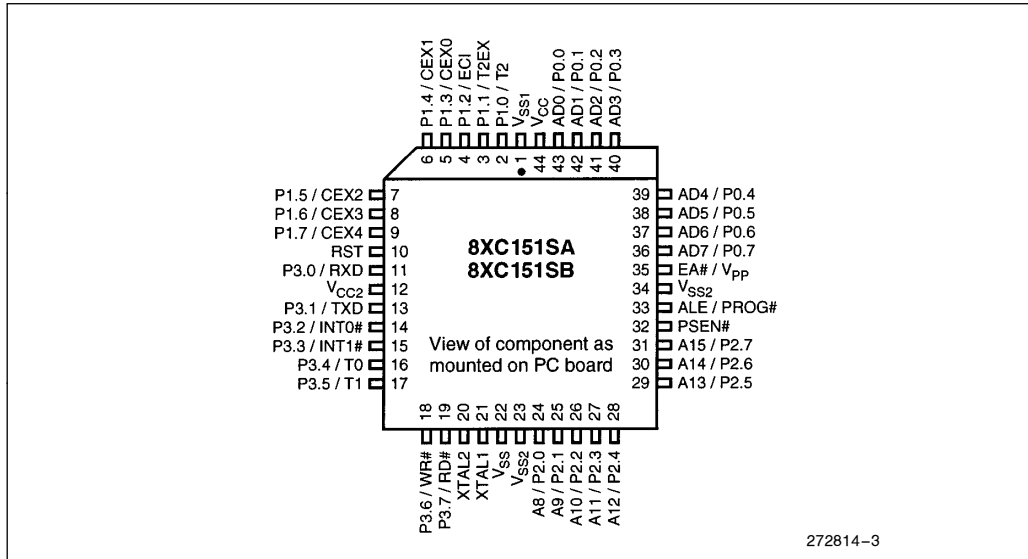

Figure 3. 8XC151SA/SB 44-Lead PLCC Package

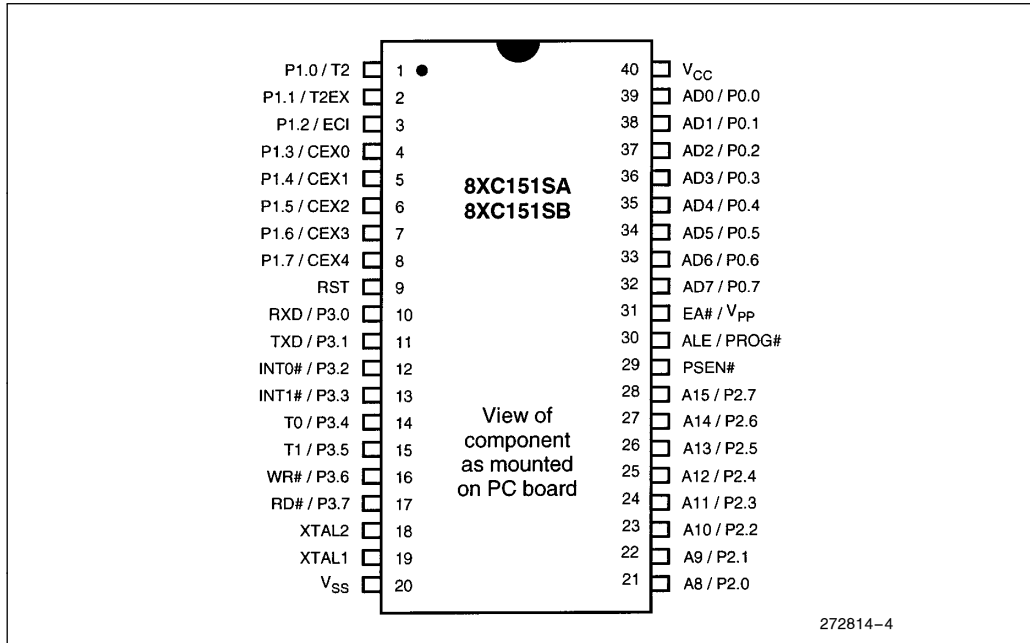

Figure 4. 8XC151SA/SB 40-Pin PDIP and Ceramic DIP Packages



8XC151SA/SB HIGH-PERFORMANCE CHMOS MICROCONTROLLER

Table 5. PLCC/DIP Signal Assignment Arranged by Functional Categories

Address & Data		
Name	PLCC	DIP
AD0/P0.0	43	39
AD1/P0.1	42	38
AD2/P0.2	41	37
AD3/P0.3	40	36
AD4/P0.4	39	35
AD5/P0.5	38	34
AD6/P0.6	37	33
AD7/P0.7	36	32
A8/P2.0	24	21
A9/P2.1	25	22
A10/P2.2	26	23
A11/P2.3	27	24
A12/P2.4	28	25
A13/P2.5	29	26
A14/P2.6	30	27
A15/P2.7	31	28

Processor Control		
Name	PLCC	DIP
P3.2/INT0 #	14	12
P3.3/INT1 #	15	13
EA # /V <sub>PP</sub>	35	31
RST	10	9
XTAL1	21	18
XTAL2	20	19

Input/Output		
Name	PLCC	DIP
P1.0/T2	2	1
P1.1/T2EX	3	2
P1.2/ECI	4	3
P1.3/CEX0	5	4
P1.4/CEX1	6	5
P1.5/CEX2	7	6
P1.6/CEX3	8	7
P1.7/CEX4	9	8
P3.0/RXD	11	10
P3.1/TXD	13	11
P3.4/T0	16	14
P3.5/T1	17	15

Power & Ground		
Name	PLCC	DIP
V <sub>CC</sub>	44	40
V <sub>CC2</sub>	12	—
V <sub>SS</sub>	22	20
V <sub>SS1</sub>	1	—
V <sub>SS2</sub>	23, 34	—
EA # /V <sub>PP</sub>	35	31

Bus Control & Status		
Name	PLCC	DIP
P3.6/WR #	18	16
P3.7/RD #	19	17
ALE/PROG #	33	30
PSEN #	32	29



Table 6. Signal Assignments Arranged by Package Number

PLCC	DIP	Name	PLCC	DIP	Name
1	—	V <sub>SS1</sub>	23	—	V <sub>SS2</sub>
2	1	P1.0/T2	24	21	A8/P2.0
3	2	P1.1/T2EX	25	22	A9/P2.1
4	3	P1.2/ECI	26	23	A10/P2.2
5	4	P1.3/CEX0	27	24	A11/P2.3
6	5	P1.4/CEX1	28	25	A12/P2.4
7	6	P1.5/CEX2	29	26	A13/P2.5
8	7	P1.6/CEX3	30	27	A14/P2.6
9	8	P1.7/CEX4	31	28	A15/P2.7
10	9	RST	32	29	PSEN#
11	10	P3.0/RXD	33	30	ALE/PROG#
12	—	V <sub>CC2</sub>	34	—	V <sub>SS2</sub>
13	11	P3.1/TXD	35	31	EA# /V <sub>pp</sub>
14	12	P3.2/INT0#	36	32	AD7/P0.7
15	13	P3.3/INT1#	37	33	AD6/P0.6
16	14	P3.4/T0	38	34	AD5/P0.5
17	15	P3.5/T1	39	35	AD4/P0.4
18	16	P3.6/WR#	40	36	AD3/P0.3
19	17	P3.7/RD#	41	37	AD2/P0.2
20	18	XTAL2	42	38	AD1/P0.1
21	19	XTAL1	43	39	AD0/P0.0
22	20	V <sub>SS</sub>	44	40	V <sub>CC</sub>



SIGNAL DESCRIPTIONS

Table 7. Signal Descriptions

Signal Name	Type	Description	Multiplexed With
A15:8†	O	<b>Address Lines.</b> Upper address lines for the external bus.	P2.7:0
AD7:0†	I/O	<b>Address/Data Lines.</b> Multiplexed lower address lines and data lines for external memory.	P0.7:0
ALE	O	<b>Address Latch Enable.</b> ALE signals the start of an external bus cycle and indicates that valid address information is available on lines A15:8 and AD7:0. An external latch can use ALE to demultiplex the address from the address/data bus.	PROG #
CEX4:0	I/O	<b>Programmable Counter Array (PCA) Input/Output Pins.</b> These are input signals for the PCA capture mode and output signals for the PCA compare mode and PCA PWM mode.	P1.6:3 P1.7
EA #	I	<b>External Access.</b> Directs program memory accesses to on-chip or off-chip code memory. For EA # = 0, all program memory accesses are off-chip. For EA # = 1, an access is to on-chip ROM/OTPROM if the address is within the range of the on-chip ROM/OTPROM; otherwise the access is off-chip. The value of EA # is latched at reset. For devices without on-chip ROM/OTPROM, EA # must be strapped to ground.	V <sub>PP</sub>
ECI	I	<b>PCA External Clock Input.</b> External clock input to the 16-bit PCA timer.	P1.2
INT1:0 #	I	<b>External Interrupts 0 and 1.</b> These inputs set bits IE1:0 in the TCON register. If bits IT1:0 in the TCON register are set, bits IE1:0 are set by a falling edge on INT1 # /INT0 #. If bits INT1:0 are clear, bits IE1:0 are set by a low level on INT1:0 #.	P3.3:2
PROG #	I	<b>Programming Pulse.</b> The programming pulse is applied to this pin for programming the on-chip OTPROM.	ALE
P0.7:0	I/O	<b>Port 0.</b> This is an 8-bit, open-drain, bidirectional I/O port.	AD7:0
P1.0 P1.1 P1.2 P1.7:3	I/O	<b>Port 1.</b> This is an 8-bit, bidirectional I/O port with internal pullups.	T2 T2EX ECI CEX3:0 CEX4
P2.7:0	I/O	<b>Port 2.</b> This is an 8-bit, bidirectional I/O port with internal pullups.	A15:8

† The descriptions of A15:8/P2.7:0 and AD7:0/P0.7:0 are for the nonpage-mode chip configuration (compatible with 44-lead PLCC and 40-pin DIP MCS 51 microcontrollers). If the chip is configured for page-mode operation, port 0 carries the lower address bits (A7:0), and port 2 carries the upper address bits (A15:8) and the data (D7:0).

Table 7. Signal Descriptions (Continued)

Signal Name	Type	Description	Multiplexed With
P3.0 P3.1 P3.3:2 P3.5:4 P3.6 P3.7	I/O	<b>Port 3.</b> This is an 8-bit, bidirectional I/O port with internal pullups.	RXD TXD INT1:0# T1:0 WR# RD#
PSEN#	O	<b>Program Store Enable.</b> Read signal output. This output is asserted for a memory address range that depends on bits RD0 and RD1 in configuration byte UCONFIG0.	—
RD#	O	<b>Read.</b> Read signal output to external data memory.	P3.7
RST	I	<b>Reset.</b> Reset input to the chip. Holding this pin high for 64 oscillator periods while the oscillator is running resets the device. The port pins are driven to their reset conditions when a voltage greater than $V_{IH1}$ is applied, whether or not the oscillator is running. This pin has an internal pulldown resistor, which allows the device to be reset by connecting a capacitor between this pin and $V_{CC}$ .  Asserting RST when the chip is in idle mode or powerdown mode returns the chip to normal operation.	—
RXD	I/O	<b>Receive Serial Data.</b> RXD sends and receives data in serial I/O mode 0 and receives data in serial I/O modes 1, 2, and 3.	P3.0
T1:0	I	<b>Timer 1:0 External Clock Inputs.</b> When timer 1:0 operates as a counter, a falling edge on the T1:0 pin increments the count.	P3.5:4
T2	I/O	<b>Timer 2 Clock Input/Output.</b> For the timer 2 capture mode, this signal is the external clock input. For the clock-out mode, it is the timer 2 clock output.	P1.0
T2EX	I	<b>Timer 2 External Input.</b> In timer 2 capture mode, a falling edge initiates a capture of the timer 2 registers. In auto-reload mode, a falling edge causes the timer 2 registers to be reloaded. In the up-down counter mode, this signal determines the count direction: 1 = up, 0 = down.	P1.1
TXD	O	<b>Transmit Serial Data.</b> TXD outputs the shift clock in serial I/O mode 0 and transmits serial data in serial I/O modes 1, 2, and 3.	P3.1
$V_{CC}$	PWR	<b>Supply Voltage.</b> Connect this pin to the +5V supply voltage.	—
$V_{CC2}$	PWR	<b>Secondary Supply Voltage 2.</b> This supply voltage connection is provided to reduce power supply noise. Connection of this pin to the +5V supply voltage is recommended. However, when using the 8XC151SA/SB as a pin-for-pin replacement for the 8XC51FX, $V_{SS2}$ can be unconnected without loss of compatibility. (Not available on DIP)	—
$V_{PP}$	I	<b>Programming Supply Voltage.</b> The programming supply voltage is applied to this pin for programming the on-chip OTPROM.	EA#

† The descriptions of A15:8/P2.7:0 and AD7:0/P0.7:0 are for the nonpage-mode chip configuration (compatible with 44-lead PLCC and 40-pin DIP MCS 51 microcontrollers). If the chip is configured for page-mode operation, port 0 carries the lower address bits (A7:0), and port 2 carries the upper address bits (A15:8) and the data (D7:0).



8XC151SA/SB HIGH-PERFORMANCE CHMOS MICROCONTROLLER

Table 7. Signal Descriptions (Continued)

Signal Name	Type	Description	Multiplexed With
V <sub>SS</sub>	GND	<b>Circuit Ground.</b> Connect this pin to ground.	—
V <sub>SS1</sub>	GND	<b>Secondary Ground.</b> This ground is provided to reduce ground bounce and improve power supply bypassing. Connection of this pin to ground is recommended. However, when using the 8XC151SA/SB as a pin-for-pin replacement for the 8XC51BH, V <sub>SS1</sub> can be unconnected without loss of compatibility. (Not available on DIP)	
V <sub>SS2</sub>	GND	<b>Secondary Ground 2.</b> This ground is provided to reduce ground bounce and improve power supply bypassing. Connection of this pin to ground is recommended. However, when using the 8XC151SA/SB as a pin-for-pin replacement for the 8XC51FX, V <sub>SS2</sub> can be unconnected without loss of compatibility. (Not available on DIP)	
WR#	O	<b>Write.</b> Write signal output to external memory.	P3.6
XTAL1	I	<b>Input to the On-chip, Inverting, Oscillator Amplifier.</b> To use the internal oscillator, a crystal/resonator circuit is connected to this pin. If an external oscillator is used, its output is connected to this pin. XTAL1 is the clock source for internal timing.	
XTAL2	O	<b>Output of the On-chip, Inverting, Oscillator Amplifier.</b> To use the internal oscillator, a crystal/resonator circuit is connected to this pin. If an external oscillator is used, leave XTAL2 unconnected.	—

† The descriptions of A15:8/P2.7:0 and AD7:0/P0.7:0 are for the nonpage-mode chip configuration (compatible with 44-lead PLCC and 40-pin DIP MCS 51 microcontrollers). If the chip is configured for page-mode operation, port 0 carries the lower address bits (A7:0), and port 2 carries the upper address bits (A15:8) and the data (D7:0).



**ELECTRICAL CHARACTERISTICS**

**ABSOLUTE MAXIMUM RATINGS\***

Ambient Temperature under Bias:

Commercial	.....0°C to +70°C
Express	.....-40°C to +85°C
Storage Temperature	.....-65°C to +150°C
Voltage on EA# /V <sub>PP</sub> Pin to V <sub>SS</sub>	....0V to +13.0V
Voltage on Any other Pin to V <sub>SS</sub>	...-0.5V to +6.5V
I <sub>OL</sub> per I/O Pin	.....15 mA
Power Dissipation	.....1.5W

NOTICE: This document contains information on products in the design phase of development. Do not finalize a design with this information. Revised information will be published when the product is available. Verify with your local Intel Sales office that you have the latest data sheet before finalizing a design.

*\*WARNING: Stressing the device beyond the "Absolute Maximum Ratings" may cause permanent damage. These are stress ratings only. Operation beyond the "Operating Conditions" is not recommended and extended exposure beyond the "Operating Conditions" may affect device reliability.*

**NOTE:**

Maximum power dissipation is based on package heat-transfer limitations, not device power consumption.

**OPERATING CONDITIONS\***

T<sub>A</sub> (Ambient Temperature Under Bias):

Commercial	.....0°C to +70°C
Express	.....-40°C to +85°C
V <sub>CC</sub> (Digital Supply Voltage)	.....4.5V to 5.5V
V <sub>SS</sub>	.....0V





**DC CHARACTERISTICS**

Parameter values apply to all devices unless otherwise indicated.

**Table 8. DC Characteristics at  $V_{CC} = 4.5V - 5.5V$**

Symbol	Parameter	Min	Typical	Max	Units	Test Conditions
$V_{IL}$	Input Low Voltage (except EA#)	-0.5		$0.2V_{CC} - 0.1$	V	
$V_{IL1}$	Input Low Voltage (EA#)	0		$0.2V_{CC} - 0.3$	V	
$V_{IH}$	Input High Voltage (except XTAL1, RST)	$0.2V_{CC} + 0.9$		$V_{CC} + 0.5$	V	
$V_{IH1}$	Input High Voltage (XTAL1, RST)	$0.7V_{CC}$		$V_{CC} + 0.5$	V	
$V_{OL}$	Output Low Voltage (Port 1, 2, 3)			0.3 0.45 1.0	V	$I_{OL} = 100 \mu A$ $I_{OL} = 1.6 \text{ mA}$ $I_{OL} = 3.5 \text{ mA}$ (Note 1, Note 2)
$V_{OL1}$	Output Low Voltage (Port 0, ALE, PSEN#)			0.3 0.45 1.0	V	$I_{OL} = 200 \mu A$ $I_{OL} = 3.2 \text{ mA}$ $I_{OL} = 7.0 \text{ mA}$ (Note 1, Note 2)
$V_{OH}$	Output High Voltage (Port 1, 2, 3, ALE, PSEN#)	$V_{CC} - 0.3$ $V_{CC} - 0.7$ $V_{CC} - 1.5$			V	$I_{OH} = -10 \mu A$ $I_{OH} = -30 \mu A$ $I_{OH} = -60 \mu A$ (Note 3)

**NOTES:**

1. Under steady-state (non-transient) conditions,  $I_{OL}$  must be externally limited as follows:

Maximum  $I_{OL}$  per port pin: 10 mA

Maximum  $I_{OL}$  per 8-bit port:

port 0 26 mA

ports 1-3 15 mA

Maximum Total  $I_{OL}$  for

all output pins 71 mA

If  $I_{OL}$  exceeds the test conditions,  $V_{OL}$  may exceed the related specification. Pins are not guaranteed to sink current greater than the listed test conditions.

2. Capacitive loading on ports 0 and 2 may cause spurious noise pulses above 0.4V on the low-level outputs of ALE and ports 1, 2, and 3. The noise is due to external bus capacitance discharging into the port 0 and port 2 pins when these pins change from high to low. In applications where capacitive loading exceeds 100 pF, the noise pulses on these signals may exceed 0.8V. It may be desirable to qualify ALE or other signals with a Schmitt trigger or CMOS-level input logic.

3. Capacitive loading on ports 0 and 2 causes the  $V_{OH}$  on ALE and PSEN# to drop below the specification when the address lines are stabilizing.

4. Typical values are obtained using  $V_{CC} = 5.0$ ,  $T_A = 25^\circ C$  and are not guaranteed.

Table 8. DC Characteristics at  $V_{CC} = 4.5V - 5.5V$  (Continued)

Symbol	Parameter	Min	Typical	Max	Units	Test Conditions
$V_{OH1}$	Output High Voltage (Port 0 in External Address)	$V_{CC} - 0.3$ $V_{CC} - 0.7$ $V_{CC} - 1.5$			V	$I_{OH} = -200 \mu A$ $I_{OH} = -3.2 mA$ $I_{OH} = -7.0 mA$
$V_{OH2}$	Output High Voltage (Port 2 in External Address during Page Mode)	$V_{CC} - 0.3$ $V_{CC} - 0.7$ $V_{CC} - 1.5$			V	$I_{OH} = -200 \mu A$ $I_{OH} = -3.2 mA$ $I_{OH} = -7.0 mA$
$I_{IL}$	Logical 0 Input Current (Port 1, 2, 3)			-50	$\mu A$	$V_{IN} = 0.45V$
$I_{LI}$	Input Leakage Current (Port 0)			$\pm 10$	$\mu A$	$0.45 < V_{IN} < V_{CC}$
$I_{TL}$	Logical 1-to-0 Transition Current (Port 1, 2, 3)			-650	$\mu A$	$V_{IN} = 2.0V$
$R_{RST}$	RST Pulldown Resistor	40		225	$k\Omega$	
$C_{IO}$	Pin Capacitance		10 (Note 4)		pF	$F_{OSC} = 16 MHz$ $T_A = 25^\circ C$
$I_{PD}$	Powerdown Current		10 (Note 4)	< 20	$\mu A$	
$I_{DL}$	Idle Mode Current		13 (Note 4)	20	mA	$F_{OSC} = 16 MHz$
$I_{CC}$	Operating Current		71 (Note 4)	85	mA	$F_{OSC} = 16 MHz$

**NOTES:**

- Under steady-state (non-transient) conditions,  $I_{OL}$  must be externally limited as follows:

Maximum  $I_{OL}$  per port pin: 10 mA

Maximum  $I_{OL}$  per 8-bit port:

port 0 26 mA

ports 1-3 15 mA

Maximum Total  $I_{OL}$  for

all output pins 71 mA

If  $I_{OL}$  exceeds the test conditions,  $V_{OL}$  may exceed the related specification. Pins are not guaranteed to sink current greater than the listed test conditions.

- Capacitive loading on ports 0 and 2 may cause spurious noise pulses above 0.4V on the low-level outputs of ALE and ports 1, 2, and 3. The noise is due to external bus capacitance discharging into the port 0 and port 2 pins when these pins change from high to low. In applications where capacitive loading exceeds 100 pF, the noise pulses on these signals may exceed 0.8V. It may be desirable to qualify ALE or other signals with a Schmitt trigger or CMOS-level input logic.
- Capacitive loading on ports 0 and 2 causes the  $V_{OH}$  on ALE and PSEN# to drop below the specification when the address lines are stabilizing.
- Typical values are obtained using  $V_{CC} = 5.0$ ,  $T_A = 25^\circ C$  and are not guaranteed.



8XC151SA/SB HIGH-PERFORMANCE CMOS MICROCONTROLLER

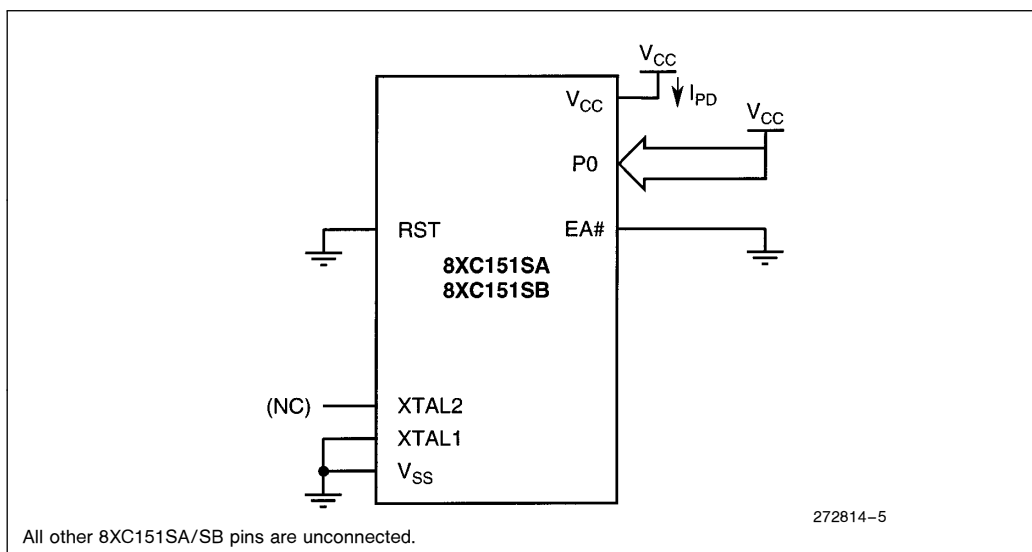

Figure 5.  $I_{PD}$  Test Condition, Powerdown Mode,  $V_{CC} = 2.0V - 5.5V$



### AC Characteristics

Table 8 lists AC timing parameters for the 8XC151SA/SB with no wait states. External wait states can be added by extending PSEN#/RD#/WR# and/or by extending ALE. In the table, Notes 3 and 5 mark parameters affected by an ALE wait

state, and Notes 4 and 5 mark parameters affected by a PSEN#/RD#/WR# wait state.

Figures 5–11 show the bus cycles with the timing parameters.

**Table 9. AC Characteristics (Capacitive Loading = 50 pF)**

Symbol	Parameter	@ Max Fosc (1)		Fosc Variable		Units
		Min	Max	Min	Max	
F <sub>OSC</sub>	XTAL1 Frequency	N/A	N/A	0	16	MHz
T <sub>OSC</sub>	1/F <sub>OSC</sub> @ 12 MHz @ 16 MHz	N/A	N/A	83.3 62.5		ns
T <sub>LHLL</sub>	ALE Pulse Width @ 12 MHz @ 16 MHz	68.3 47.5		(1 + 2M) T <sub>OSC</sub> - 15		ns (3)
T <sub>AVLL</sub>	Address Valid to ALE Low @ 12 MHz @ 16 MHz	58.3 37.5		(1 + 2M) T <sub>OSC</sub> - 25		ns (3)
T <sub>LLAX</sub>	Address Hold after ALE Low @ 12 MHz @ 16 MHz	10 10		10		ns
T <sub>RLRH</sub> (2)	RD# or PSEN# Pulse Width @ 12 MHz @ 16 MHz	151.6 110		2(1 + N) T <sub>OSC</sub> - 15		ns (4)
T <sub>WLWH</sub>	WR# Pulse Width @ 12 MHz @ 16 MHz	151.6 110		2(1 + N) T <sub>OSC</sub> - 15		ns (4)
T <sub>LLRL</sub> (2)	ALE Low to RD# or PSEN# Low @ 12 MHz @ 16 MHz	58.3 37.5		T <sub>osc</sub> - 25		ns
T <sub>LHAX</sub>	ALE High to Address Hold @ 12 MHz @ 16 MHz	83.3 62.5		(1 + 2M) T <sub>OSC</sub>		ns (3)

#### NOTES:

1. 16 MHz.
2. Specifications for PSEN# are identical to those for RD#.
3. In the formula, M=Number of wait states (0 or 1) for ALE.
4. In the formula, N=Number of wait states (0, 1, 2, or 3) for RD#/PSEN#/WR#.
5. "Typical" specifications are untested and not guaranteed.



8XC151SA/SB HIGH-PERFORMANCE CHMOS MICROCONTROLLER

Table 9. AC Characteristics (Capacitive Loading = 50 pF) (Continued)

Symbol	Parameter	@ Max Fosc (1)		Fosc Variable		Units
		Min	Max	Min	Max	
T <sub>RLDV</sub> (2)	RD# / PSEN# Low to valid Data/Instruction In @ 12 MHz @ 16 MHz		111.6 70		2(1+N) T <sub>OSC</sub> - 55	ns (4)
T <sub>RHDx</sub> (2)	RD# / PSEN# Data/Instruction Hold after RD# and PSEN# High	0		0		ns
T <sub>RLAZ</sub> (2)	RD# / PSEN# Low to Address Float	Typ. = 0 (5)	2	Typ. = 0 (5)	2	ns
T <sub>RHDZ1</sub>	Instruction Float after RD# / PSEN# High @ 12 MHz @ 16 MHz		0 0		0	ns
T <sub>RHDZ2</sub>	Data Float after RD# / PSEN# High @ 12 MHz @ 16 MHz		151.6 110		2T <sub>OSC</sub> - 15	ns
T <sub>RHLH1</sub>	RD# / PSEN# High to ALE High (Instruction) @ 12 MHz @ 16 MHz	0 0		0		ns
T <sub>RHLH2</sub>	RD# / PSEN# High to ALE High (Data) @ 12 MHz @ 16 MHz	156.6 115		2T <sub>OSC</sub> - 10		ns
T <sub>WHLH</sub>	WR# High to ALE High @ 12 MHz @ 16 MHz	166.6 125		2T <sub>OSC</sub>		ns
T <sub>AVDV1</sub>	Address (P0) Valid to Valid Data/Instruction In @ 12 MHz @ 16 MHz		253.2 170		4(1+M/2) T <sub>OSC</sub> - 80	ns (3)
T <sub>AVDV2</sub>	Address (P2) Valid to Valid Data/Instruction In @ 12 MHz @ 16 MHz		268.2 185		4(1+M/2) T <sub>OSC</sub> - 65	ns (3)
T <sub>AVDV3</sub>	Address (P0) Valid to Valid Instruction In @ 12 MHz @ 16 MHz		116.6 75		2T <sub>OSC</sub> - 50	ns

NOTES:

1. 16 MHz.
2. Specifications for PSEN# are identical to those for RD#.
3. In the formula, M = Number of wait states (0 or 1) for ALE.
4. In the formula, N = Number of wait states (0, 1, 2, or 3) for RD# / PSEN# / WR#.
5. "Typical" specifications are untested and not guaranteed.



Table 9. AC Characteristics (Capacitive Loading = 50 pF) (Continued)

Symbol	Parameter	@ Max F <sub>osc</sub> (1)		F <sub>osc</sub> Variable		Units
		Min	Max	Min	Max	
T <sub>AVRL</sub> (2)	Address Valid to RD#/PSEN# Low @ 12 MHz @ 16 MHz	126.6 85		2(1 + M) T <sub>OSC</sub> - 40		ns (3)
T <sub>AVWL1</sub>	Address (P0) Valid to WR# Low @ 12 MHz @ 16 MHz	126.6 85		2(1 + M) T <sub>OSC</sub> - 40		ns (3)
T <sub>AVWL2</sub>	Address (P2) Valid to WR# Low @ 12 MHz @ 16 MHz	141.6 100		2(1 + M) T <sub>OSC</sub> - 25		ns (3)
T <sub>WHQX</sub>	Data Hold after WR# High @ 12 MHz @ 16 MHz	58.3 37.5		T <sub>OSC</sub> - 25		ns
T <sub>QVWH</sub>	Data Valid to WR# High @ 12 MHz @ 16 MHz	146.6 105		2(1 + N) T <sub>OSC</sub> - 20		ns (4)
T <sub>WHAX</sub>	WR# High to Address Hold @ 12 MHz @ 16 MHz	146.6 105		2T <sub>OSC</sub> - 20		ns

**NOTES:**

- 16 MHz.
- Specifications for PSEN# are identical to those for RD#.
- In the formula, M = Number of wait states (0 or 1) for ALE.
- In the formula, N = Number of wait states (0, 1, 2, or 3) for RD#/PSEN#/WR#.
- "Typical" specifications are untested and not guaranteed.



SYSTEM BUS TIMINGS

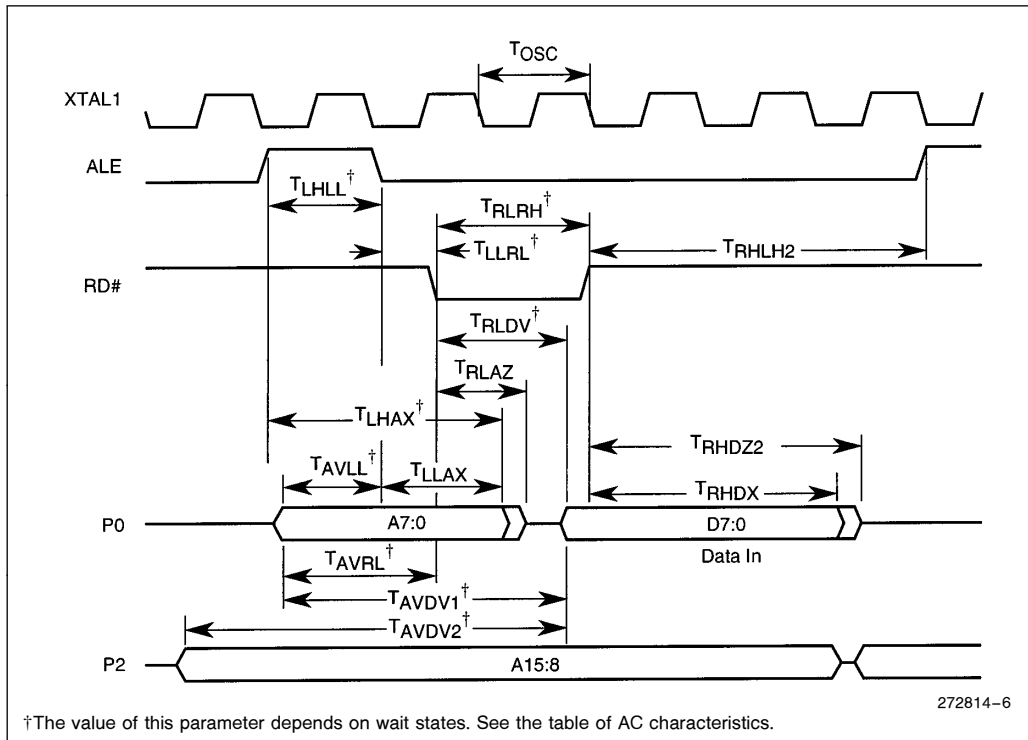

Figure 6. External Read Data Bus Cycle in Nonpage Mode

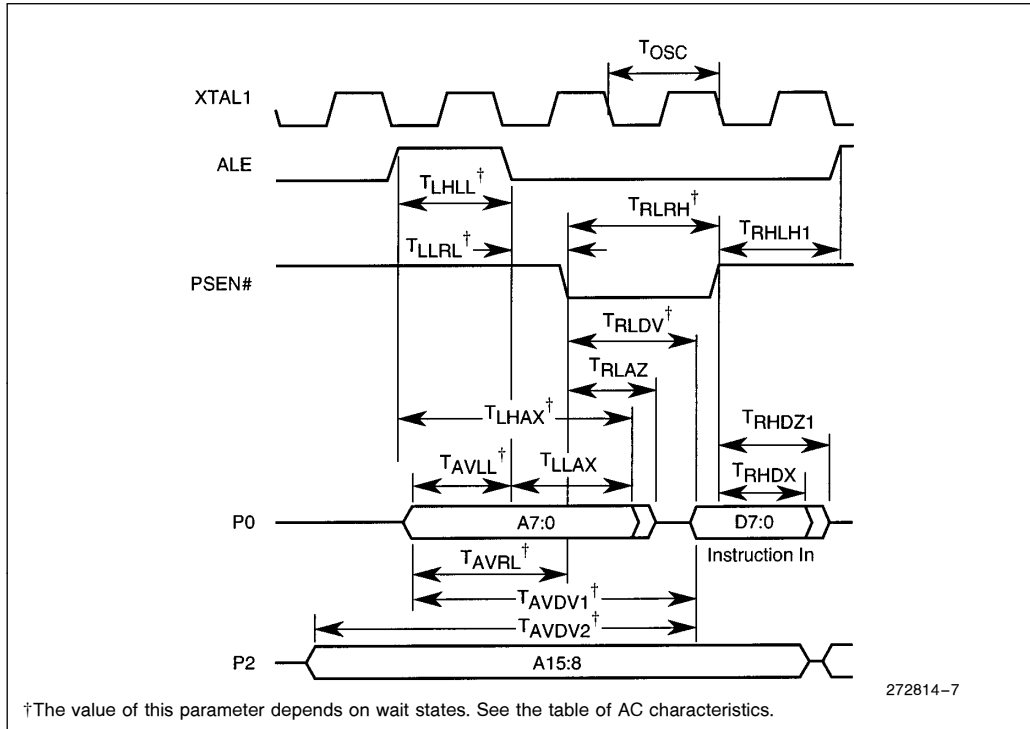

Figure 7. External Instruction Bus Cycle in Nonpage Mode

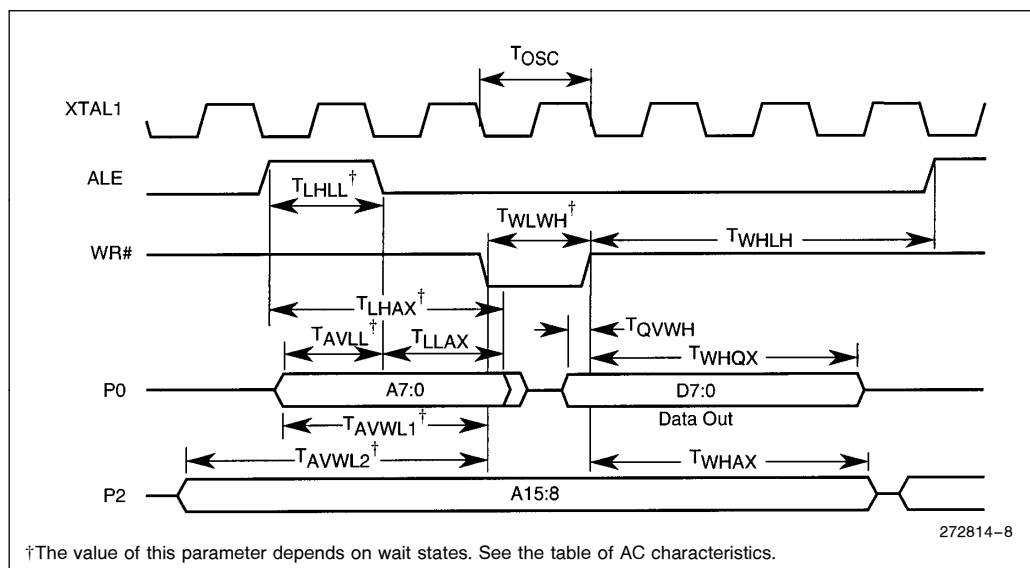

Figure 8. External Write Data Bus Cycle in Nonpage Mode

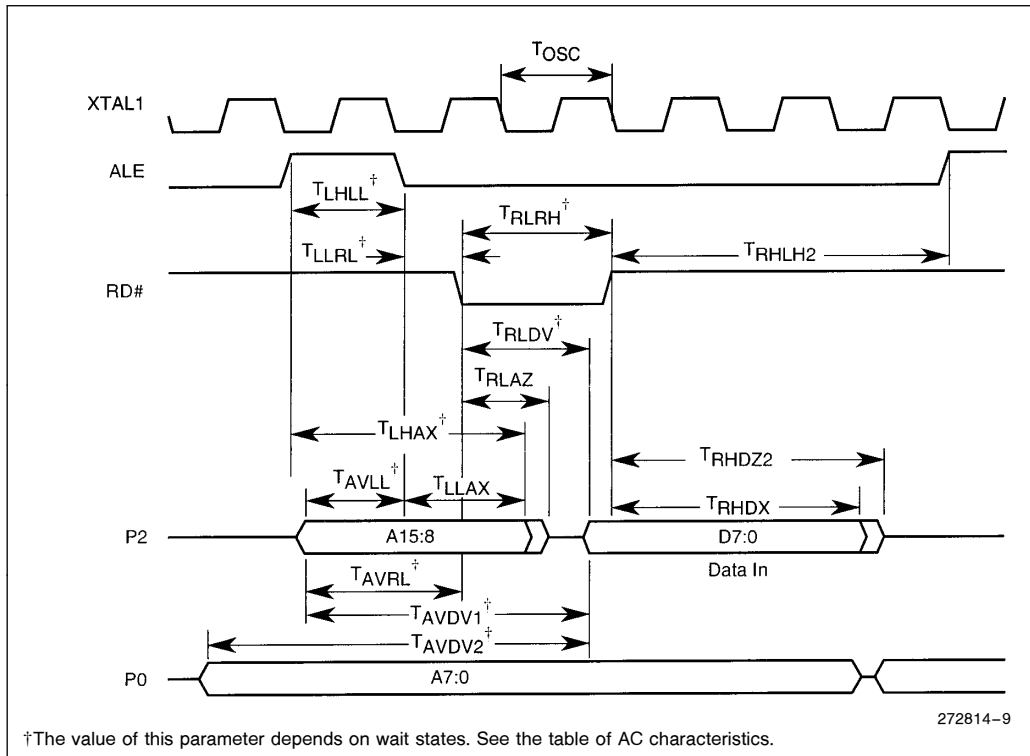

Figure 9. External Read Data Bus Cycle in Page Mode

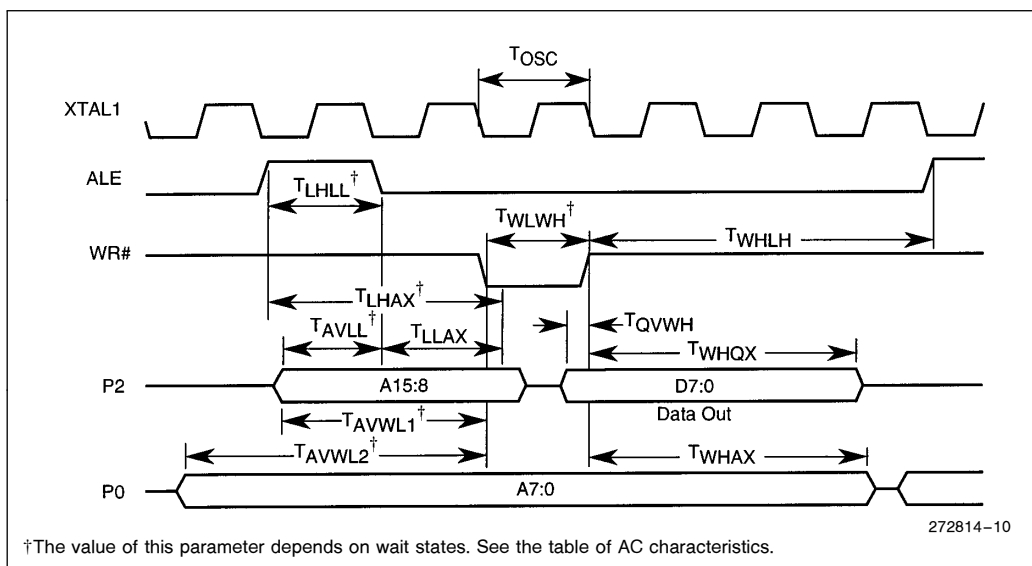

Figure 10. External Write Data Bus Cycle in Page Mode

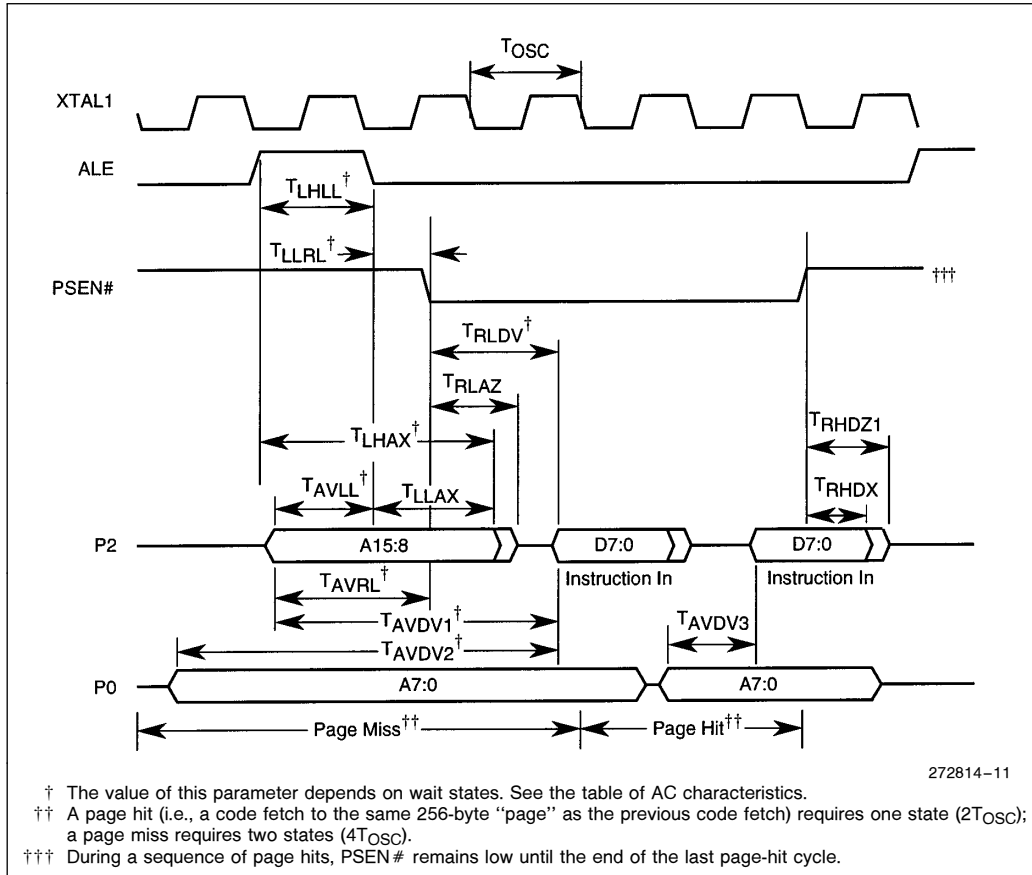

Figure 11. External Instruction Bus Cycle in Page Mode



AC Characteristics—Serial Port, Shift Register Mode

Table 10. Serial Port Timing Shift Register Mode

Symbol	Parameter	Min	Max	Units
$T_{XLXL}$	Serial Port Clock Cycle Time	$12T_{OSC}$		ns
$T_{QVSH}$	Output Data Setup to Clock Rising Edge	$10T_{OSC} - 133$		ns
$T_{XHGX}$	Output Data Hold after Clock Rising Edge	$2T_{OSC} - 117$		ns
$T_{XHDX}$	Input Data Hold after Clock Rising Edge	0		ns
$T_{XHDX}$	Clock Rising Edge to Input Data Valid		$10T_{OSC} - 133$	ns

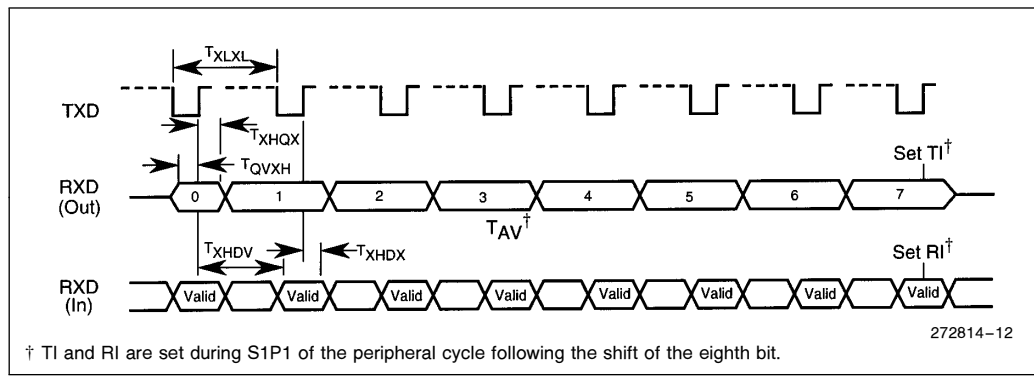

Figure 12. Serial Port Waveform —Shift Register Mode

External Clock Drive

Table 11. External Clock Drive

Symbol	Parameter	Min	Max	Units
$1/T_{CLCL}$	Oscillator Frequency ( $F_{OSC}$ )		16	MHz
$T_{CHCX}$	High Time	20		ns
$T_{CLCX}$	Low Time	20		ns
$T_{CLCH}$	Rise Time		10	ns
$T_{CHCL}$	Fall Time		10	ns

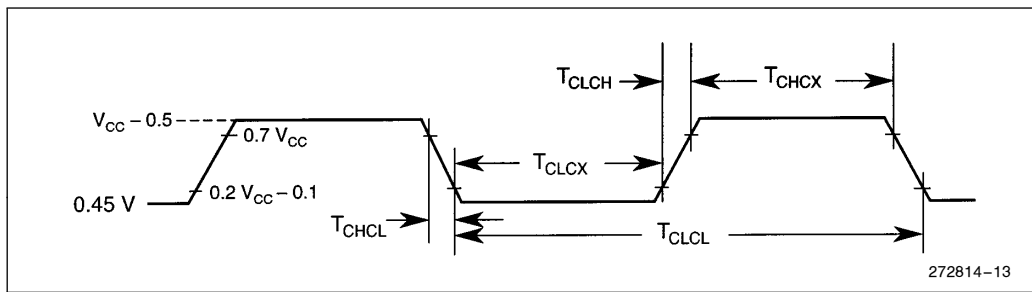

Figure 13. External Clock Drive Waveforms

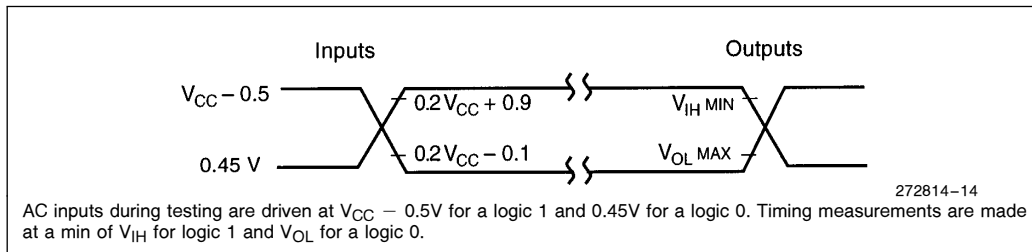
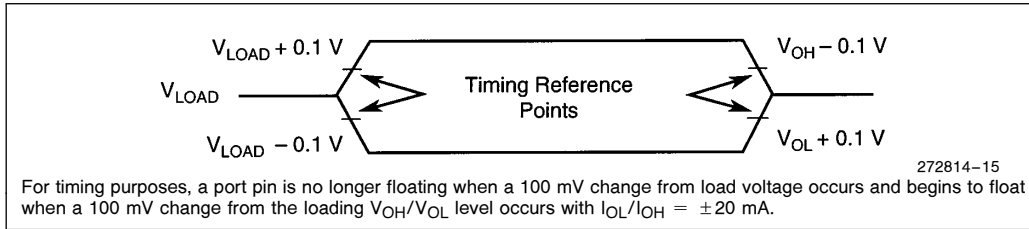

Figure 14. AC Testing Input, Output Waveforms



**8XC151SA/SB HIGH-PERFORMANCE CHMOS MICROCONTROLLER**



**Figure 15. Float Waveforms**

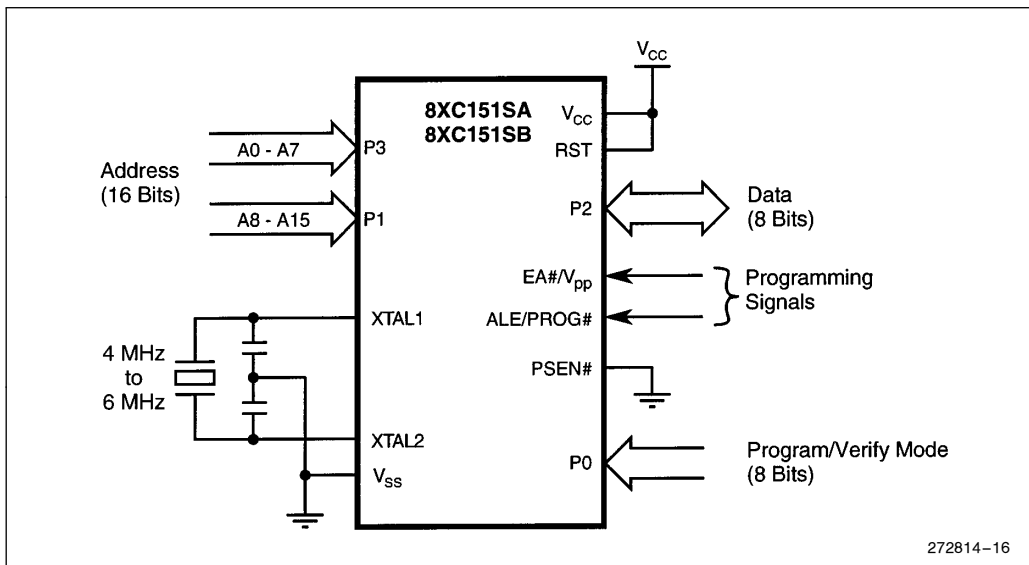

**Figure 16. Setup for Programming and Verifying Nonvolatile Memory**



## PROGRAMMING AND VERIFYING NONVOLATILE MEMORY

The 87C151SA/SB has several areas of nonvolatile memory that can be programmed and/or verified: on-chip code memory (8/16 Kbytes), lock bits (3 bits), encryption array (128 bytes), and signature bytes (3 bytes).

Figure 16 shows the setup for programming and/or verifying the nonvolatile memory. Table 11 lists the programming and verification operations and indicates which operations apply to the different versions of the 87C151SA/SB. It also specifies the signals on the programming input (PROG#) and the ports. The ROM/OTPROM mode (port 0) specifies the operation (program or verify) and the base address of the memory area. The addresses (ports 1 and 3) are relative to the base address. (On-chip memory for a 16-Kbyte ROM/OTPROM device is located at address range 0000H–3FFFH. The other areas of the ROM/OTPROM are outside the memory address space and are accessible only during programming and verification.)

Information in Figures 17 and 18 define the configuration bits. Figure 19 shows the waveforms for the programming and verification cycles, and Table 12 lists the timing specifications. The signature bytes of the 83C151SA/SB ROM versions and the 87C151SA/SB OTPROM versions are factory programmed. Table 13 lists the addresses and the contents of the signature bytes.

Factory-programmed ROM and OTPROM versions of 8XC151SA/SB use configuration byte information supplied in a separate hexadecimal disk file. 8XC151SA/SB devices without internal ROM/OTPROM arrays fetch configuration byte information from external application memory based on an internal address range of FFF9:8H.

### NOTE:

The  $V_{PP}$  source in Figure 16 must be well regulated and free of glitches. The voltage on the  $V_{PP}$  pin must not exceed the specified maximum, even under transient conditions.



## 8XC151SA/SB HIGH-PERFORMANCE CHMOS MICROCONTROLLER

**Table 12. Programming and Verification Modes Mode**

Mode	8XC151SA/SB		PROG#	P0	P2	Addresses P1 (high), P3 (low)	Notes
	X = 7	X = 3					
Program On-Chip Code Memory	Y		5 Pulses	68H	Data	0000H–3FFFH (16K) 0000H–1FFFH (8K)	1
Verify On-Chip Code Memory	Y	Y	High	28H	Data	0000H–3FFFH (16K) 0000H–1FFFH (8K)	
Program Configuration Bytes							2
Verify Configuration Bytes							2
Program Lock Bits	Y		25 Pulses	6BH	XX	0001H–0003H	1, 3
Verify Lock Bits	Y	Y	High	2BH	Data	0000H	4
Program Encryption Array	Y		25 Pulses	6CH	Data	0000H–007FH	1
Verify Signature Bytes	Y	Y	High	29H	Data	0030H, 0031H, 0060H	

**NOTES:**

1. The PROG# pulse waveform is shown in Figure 19.
2. Factory-programmed ROM and OTPROM versions of 8XC151SA/SB use configuration byte information supplied in a separate hexadecimal disk file. 8XC151SA/SB devices without internal ROM/OTPROM arrays fetch configuration byte information from external application memory based on an internal address range of FFF9:8H.
3. When programming the lock bits, the data bits on port 2 are don't care. Identify the lock bits with the address as follows: LB3 - 0003H, LB2 - 0002H, LB1 - 0001H.
4. The three lock bits are verified in a single operation. The states of the lock bits appear simultaneously at port 2 as follows: LB3 - P2.3, LB2 - P2.2. LB1 - P2.1. High = programmed.

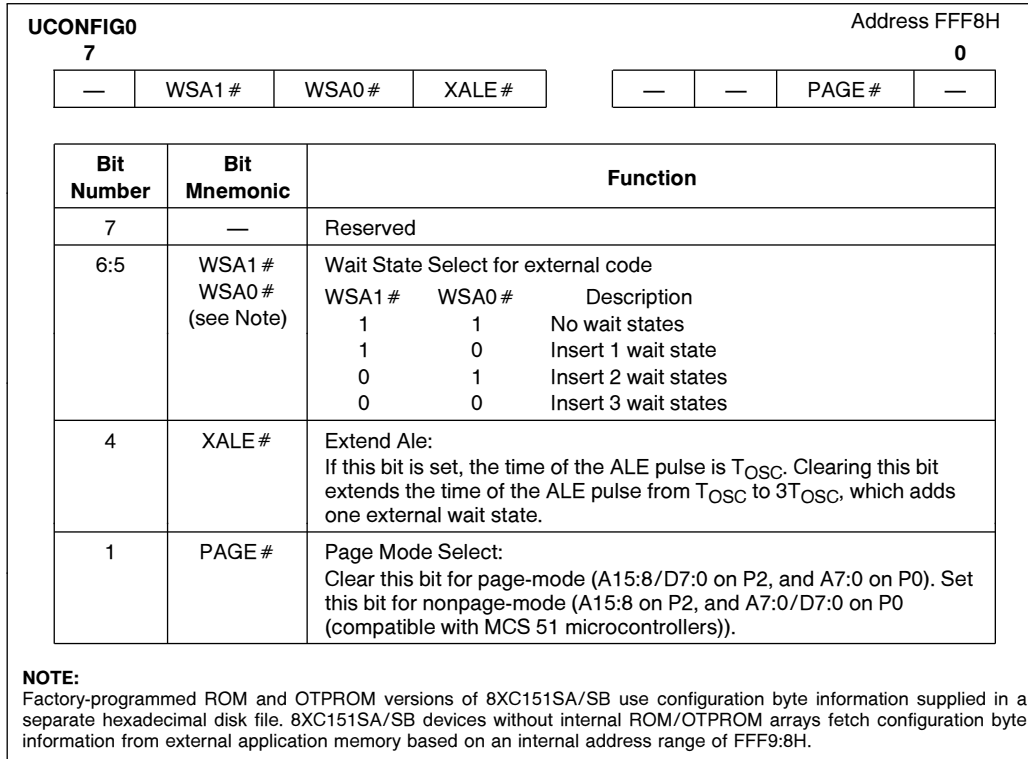

Figure 17. Configuration Byte 0



8XC151SA/SB HIGH-PERFORMANCE CHMOS MICROCONTROLLER

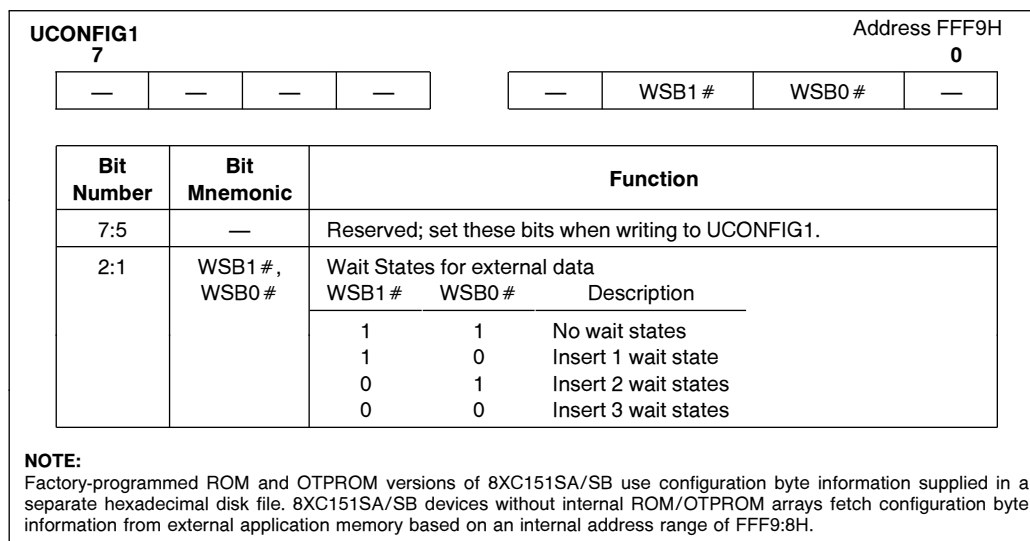

Figure 18. Configuration Byte 1

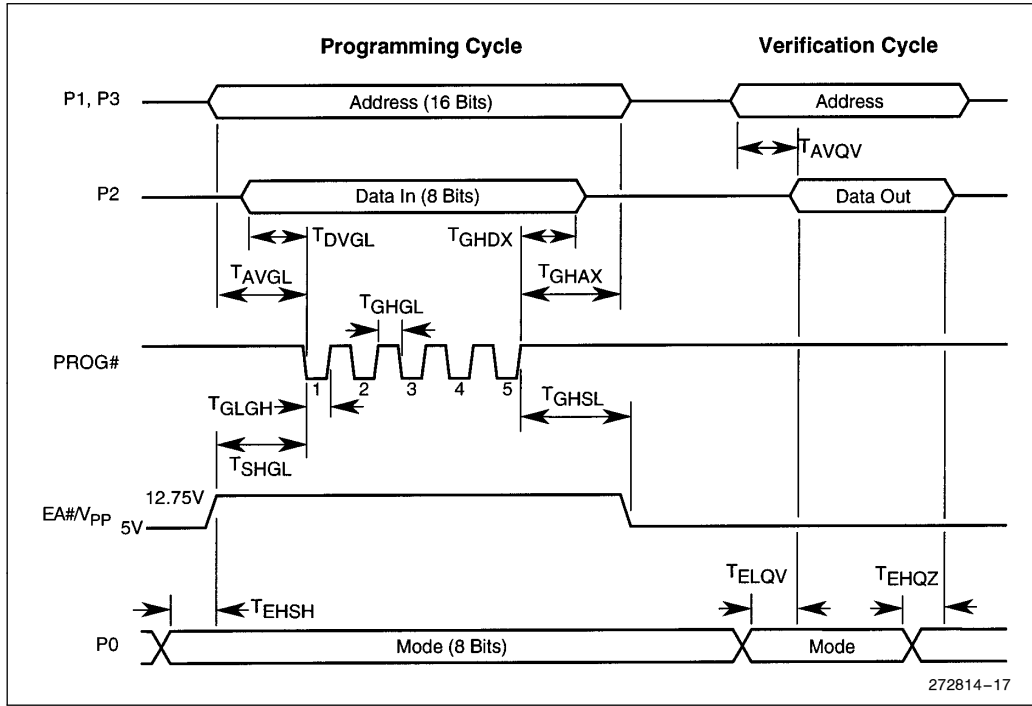

Figure 19. Timing for Programming and Verification of Nonvolatile Memory



## 8XC151SA/SB HIGH-PERFORMANCE CMOS MICROCONTROLLER

**Table 13. Nonvolatile Memory Programming and Verification Characteristics at  
T<sub>A</sub> = 21 – 27°C, V<sub>CC</sub> = 5V, and V<sub>SS</sub> = 0V**

Symbol	Definition	Min	Max	Units
V <sub>PP</sub>	Programming Supply Voltage	12.5	13.5	D.C. Volts
I <sub>PP</sub>	Programming Supply Current		75	mA
F <sub>OSC</sub>	Oscillator Frequency	4.0	6.0	MHz
T <sub>AVGL</sub>	Address Setup to PROG # Low	48T <sub>OSC</sub>		
T <sub>GHAX</sub>	Address Hold after PROG #	48T <sub>OSC</sub>		
T <sub>DVGL</sub>	Data Setup to PROG # Low	48T <sub>OSC</sub>		
T <sub>GHDX</sub>	Data Hold after PROG #	48T <sub>OSC</sub>		
T <sub>EHS</sub>	ENABLE High to V <sub>PP</sub>	48T <sub>OSC</sub>		
T <sub>SHGL</sub>	V <sub>PP</sub> Setup to PROG # Low	10		μs
T <sub>GHSL</sub>	V <sub>PP</sub> Hold after PROG #	10		μs
T <sub>GLGH</sub>	PROG # Width	90	110	μs
T <sub>AVQV</sub>	Address to Data Valid		48T <sub>OSC</sub>	
T <sub>ELQV</sub>	ENABLE Low to Data Valid		48T <sub>OSC</sub>	
T <sub>EHQZ</sub>	Data Float after ENABLE	0	48T <sub>OSC</sub>	
T <sub>GHGL</sub>	PROG # High to PROG # Low	10		μs

**NOTE:**

Notation for timing parameters:

A = Address    D = Data    E = Enable    G = PROG #    H = High    L = Low  
 Q = Data out    S = Supply (V<sub>PP</sub>)    V = Valid    X = No Longer Valid    Z = Floating

**Table 14. Contents of the Signature Bytes**

ADDRESS	CONTENTS	DEVICE TYPE
30H	89H	Indicates Intel Devices
31H	48H	Indicates MCS 151 core product
60H	7BH	Indicates 83C151SB device
60H	FBH	Indicates 87C151SB device
60H	7AH	Indicates 83C151SA device
60H	FAH	Indicates 87C151SA device

Copyright © Each Manufacturing Company.

All Datasheets cannot be modified without permission.

This datasheet has been download from :

[www.AllDataSheet.com](http://www.AllDataSheet.com)

100% Free DataSheet Search Site.

Free Download.

No Register.

Fast Search System.

[www.AllDataSheet.com](http://www.AllDataSheet.com)