



PC Audio Resistor Network

Features

- Signal conditioning and gain setting resistors for all standard audio functions
- Low noise thin film resistors $\pm 1\%$ match
- Better than 1% matching between channels
- Gain modification by changing resistors externally
- Better than -90dB inter-channel and channel-to-channel crosstalk
- Single 28-pin QSOP package
- Saves board space and reduces assembly cost

Applications

- Analog audio system for Pentium II Class personal computers, used in conjunction with Audio Codec, CS4297 or AD1819A.

Product Description

High quality audio systems have become standard for most personal computers. Furthermore, the audio functions have been migrating to the motherboard, putting pressure on available board space. The PACAC97 provides the components necessary for signal conditioning of analog audio inputs for an AC97 compliant Codec as well as gain setting resistors for headphone and microphone amplifiers. Since analog signal levels can be as high as $2V_{rms}$, the PACAC97 provides 6dB of attenuation (to $1V_{rms}$) for LINE-IN, AUX, and CD inputs. The CD line level inputs of the PACAC97 have an additional ground signal, CD_GND, that supports the pseudo differential amplifier present in AC97 Codecs. This feature facilitates attenuation of common mode ground noise typically present at the output of CD ROM

drives. Connecting the CD pins as indicated in the application circuit provides attenuation of common mode noise from the CD inputs, thereby producing a higher quality CD signal. Finally, the device provides gain-setting resistors for the headphone and microphone amplifiers. The PACAC97 provides exceptional inter-channel and channel-to-channel crosstalk attenuation necessary for high quality audio.

The PACAC97 provides performance, high reliability, and low cost through manufacturing efficiency, utilizing high volume and low cost IC manufacturing and processes. The process yields low noise and highly stable resistors demanded in audio applications. In addition, the 28-pin QSOP package is an industry standard that is easy to handle in manufacturing and provides package reliability

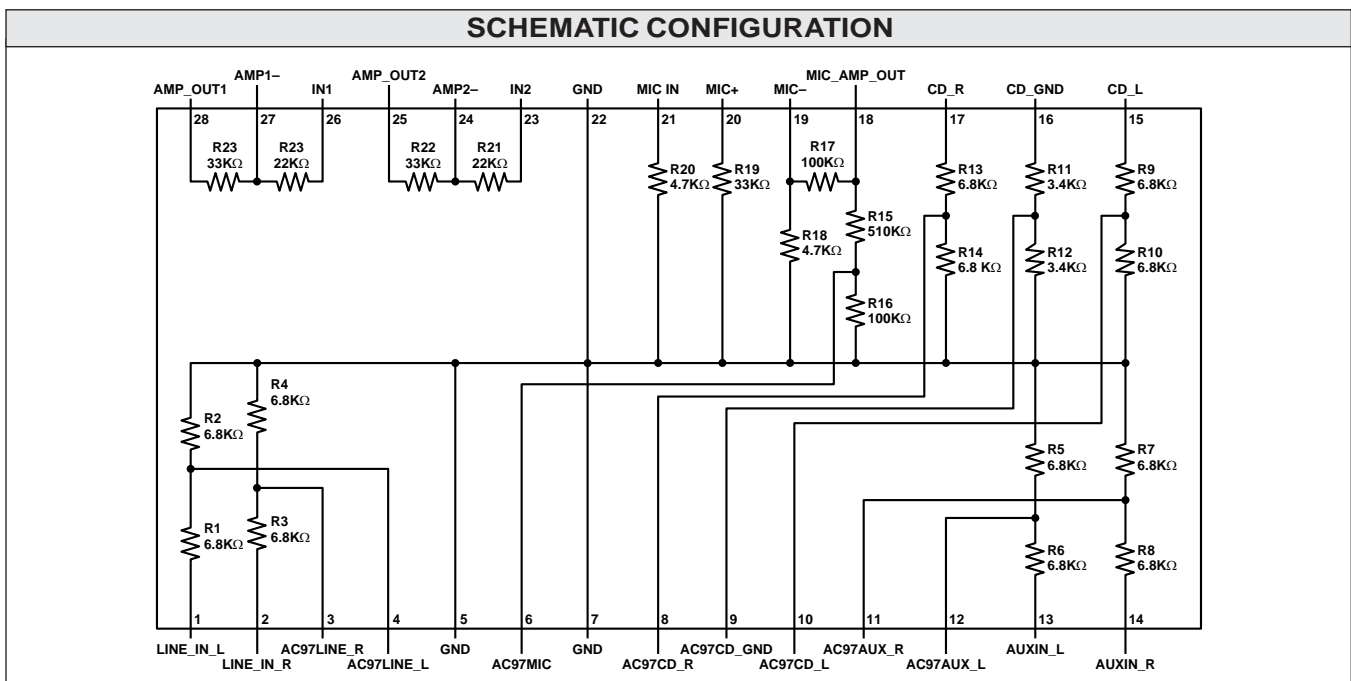

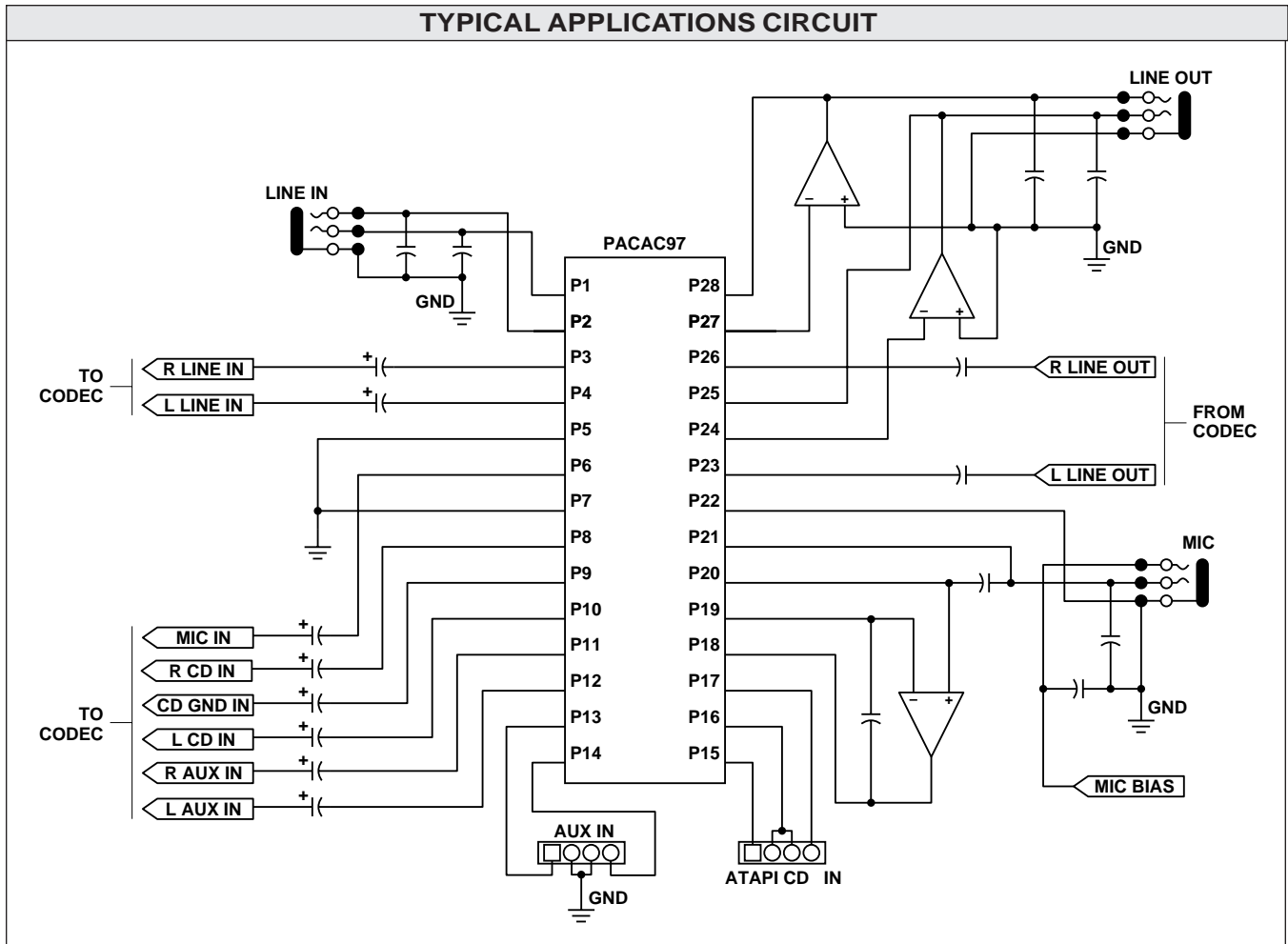

R1, R2 and R3, R4 provide 6dB pads for the LINE-IN stereo signals in order to scale a 2Vrms input to a 1Vrms Codec input. Similarly, R5, R6, R7, R8 and R9, R10, R13, R14 provide the necessary attenuation for the AUX and CD signals going to the Codec. With an external Operational Amplifier, resistors R17 and R18 provide nominally 27dB of gain for the microphone signal (non-inverting amp). R15, R16 divide down the microphone output signal, thereby protecting the Codec from any transient voltages coming from the microphone amplifier. This is particularly important if this amplifier runs of $\pm 12V$ supplies. The R15/R16 divider can be bypassed with an external 0Ω jumper connection, if so desired. Bias voltage needs to be provided for condenser type microphones. Resistors R21, R22, R23 and R24 are the gain setting resistors for the headphone amplifier. The gain is set at 3.5dB with the output amplifiers in an inverting configuration. The output gain can be changed with the addition of external resistors,

allowing for maximum design flexibility. The resistors are referenced as Amp1 and Amp2 rather than Left and Right to provide added flexibility for board layout. LINE-IN, LINE-OUT and MIC jack signals are externally decoupled in order to minimize EMI.

Crosstalk Test Circuit

Cross talk is a critical parameter for high quality audio. Specifically, stereo cross talk (Left to Right) and channel to channel cross talk must be minimized. For this reason much attention has been paid to the circuit layout of the PACAC97 in order to provide the necessary damping for signals in the 20Hz–20KHz audio band. Three examples are provided to illustrate inter-channel and channel-channel cross talk measurements that have been performed on the PACAC97. Similar measurements were performed for all audio functions deemed critical because of layout considerations.



Channel-to-Channel Crosstalk: Microphone CD

Figure 1 shows a cross talk measurement of the microphone to the Right Codec CD signal. The microphone amplifier output pin (pin 18) is driven with a 2Vrms signal. The Right CD Codec signal is terminated by a

10KΩ load resistor while pins 5,7,17 and 22 on the device are grounded. Crosstalk measured over the audio band of 20Hz–20KHz is in excess of –90dB.

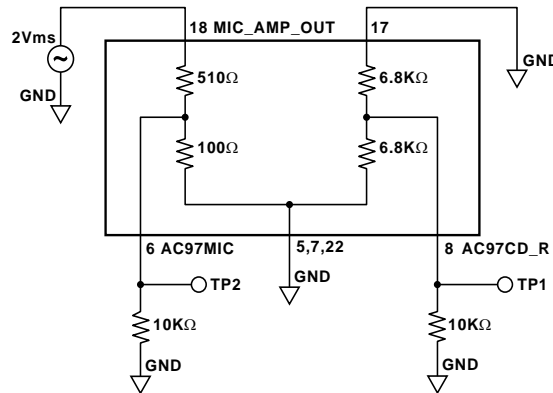

Figure 1*.

Inter-channel Crosstalk: AMP2-AMP1 (LINE_OUT)

Figure 2 shows a crosstalk measurement of Left to Right channel for the gain setting resistors of the headphone amplifier (referred to as AMP1 and AMP2). The IN2 (output from Codec) and the AMP_OUT2 pin (pins 23 and 25) are driven by a 2Vrms source. The AMP_OUT1 is terminated by a 10KΩ resistor while the IN1 pin is

terminated with a 1KΩ resistor which represents the output impedance of the LINE_OUT output of the Codec. Pins 5, 7, 22 and 24, on the device are grounded. Crosstalk measured over the audio band of 20Hz to 20KHz is in excess of –90dB.

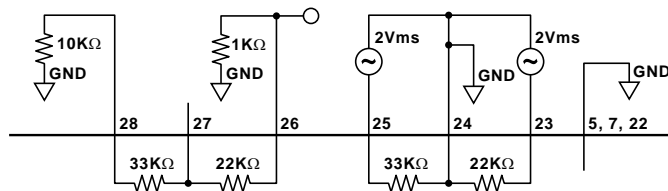

Figure 2*.



Inter-channel Crosstalk: LINE_IN_L – LINE_IN_R

Figure 3 shows a cross talk measurement for Left to Right channel for LINE_IN signals. The LINE_IN_L input is driven by a 2Vrms source. Both AC97 LINE signals are loaded by 10KΩ resistors and pins 5,7 and 22 on the

device are grounded. Crosstalk from AC97LINE_IN_L to AC97LINE_IN_R, measured over the audio band of 20Hz to 20KHz, is in excess of -90 dB.

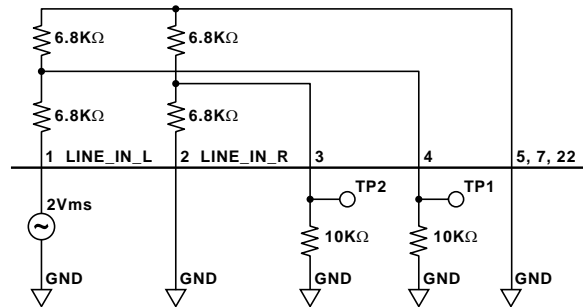

Figure 3*.

STANDARD PART ORDERING INFORMATION				
Package-Narrow		Ordering Part Number		
Pins	Style	Tubes	Tape & Reel	Part Marking
28	QSOP	PACAC97/ T	PACAC97/ R	PACAC97Q

*Measurements made using Tektronix TDS684, 5GHz digitizing oscilloscope with passive probes.