

# integrated circuits

PBD 3534

Data Sheet

## DTMF Generator

PBD 3534 is a monolithic integrated DTMF generator intended for use in a telephone set. Internal voltage reference and DC regulation make a direct connection of the circuit to the subscriber line possible. 8-bit or dual 4-bit interface capability enables PBD 3534 to be used as a computer to a telephone line interface. PBD 3534 fulfils the CEPT specification.

### Key Features

- Operates with a standard crystal at 3.58 MHz
- DC regulation is included in the circuit
- Wide operating line voltage and current range
- Internally determined ratio between the low and high frequency group level
- External control from a microprocessor is possible
- Signal level can be adjusted with one external resistor
- The signal level is stabilized against variations in temperature and line current
- All tones can be generated separately for testing
- The number of external components is minimized

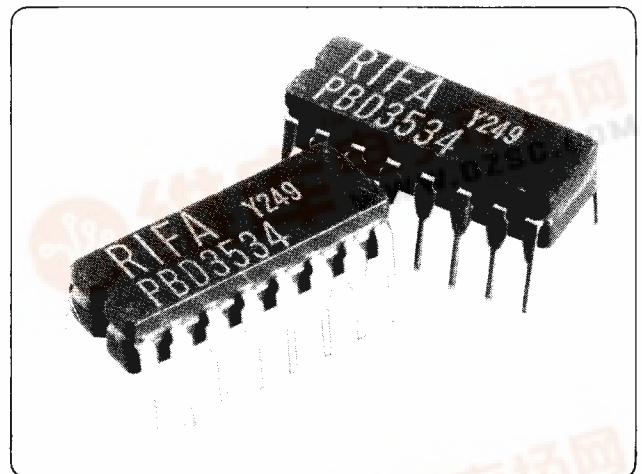

- Easy PC board layout; all keyboard connections on one side of the chip
- Short start-up time
- Inputs are protected against electrostatic discharges
- I<sup>2</sup>L process ensuring good parameter tolerances

### Functional Diagram

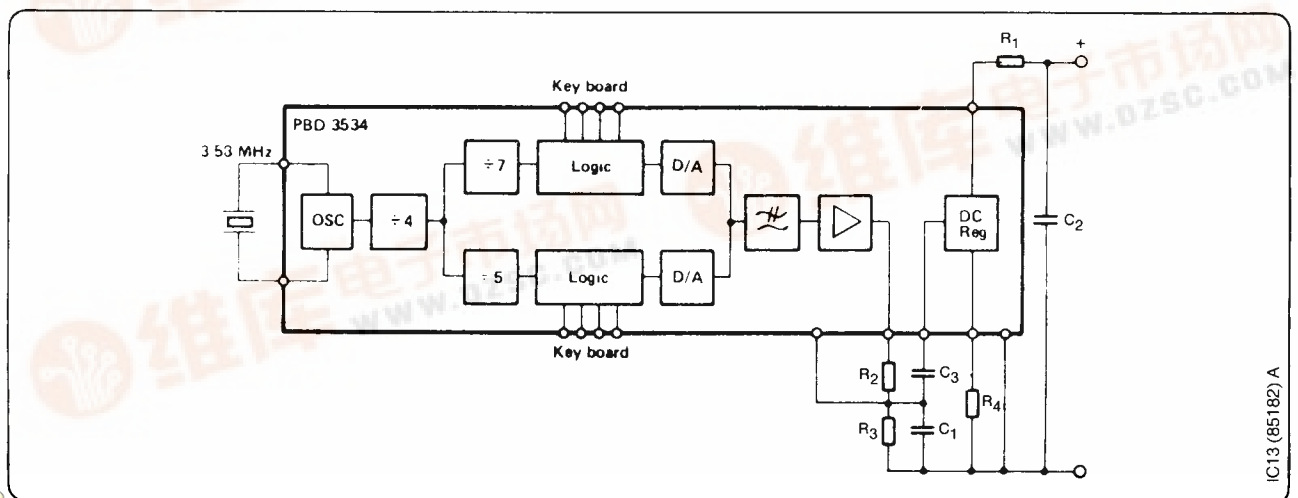

IC13 (85182) A



### Maximum Ratings

Maximum ratings over operating free-air temperature range (unless otherwise stated).

#### Voltages and Currents

Line current ( $R_5 = \infty$ )	$I_{Line}$	-120 to 100 mA
Line current ( $R_5 = 1.6 \text{ Mohm}$ )	$I_{Line}$	-120 to 130 mA
Line voltage (pulse time = 2 s)	$U_{Line}$	20 V
Line voltage (pulse time = 10 ms)	$U_{Line}$	22 V
Power dissipation	P	600 mW

#### Temperature Range

Junction temperature	$T_j$	+150 °C
Operation ambient temperature	$T_a$	-20 °C to +70 °C
Storage temperature	$T_s$	-55 °C to +150 °C

### Recommended Operating Conditions

Symbol	Parameter	Min	Typ	Max	Unit
$I_{Line}$	Line current	10		100	mA
$T_a$	Ambient temperature	-20		+50	°C
$R_5$	Current regulation resistor		$\infty$		ohm

### Electrical Characteristics

Electrical characteristics over recommended operating conditions. Reference figure 2.

Symbol	Parameter	Condition	Min	Typ	Max	Unit
$V_{Line}$	Line voltage	$I_{Line} = 10 \text{ mA}$		4.3	4.5	V
$V_{Line}$		$I_{Line} = 100 \text{ mA}$		9.7	10.6	V
$V_{Line}$		$I_{Line} = 20 \text{ mA } R_5 = 1.6 \text{ Mohm}$		4.3		V
$V_{Line}$		$I_{Line} = 130 \text{ mA } R_5 = 1.6 \text{ Mohm}$		9.7		V
	Return loss	$Z = 600 \text{ ohm}, 300\text{--}3400 \text{ Hz}$	14			dB
	Return loss	$Z = 900 \text{ ohm} // 30 \text{ nF}, 300\text{--}3400 \text{ Hz}$	14			dB
$V_{High}$	Signal level high	$R_2 = 7.87 \text{ kohm}$	-11	-9	-7	dBm
$V_{Low}$	Signal level low	$R_2 = 7.87 \text{ kohm}$	-13	-11	-9	dBm
$V_{High}$	Ratio signal level high freq/low freq	$R_2 = 5.36 \text{ kohm}$	-8	-6	-4	dBm
$V_{Low}$		$R_2 = 5.36 \text{ kohm}$	-10	-8	-6	dBm
$V_{High}$		$R_2 = 4.12 \text{ kohm}$	-6	-4	-2	dBm
$V_{Low}$		$R_2 = 4.12 \text{ kohm}$	-8	-6	-4	dBm
$V_{High}/V_{Low}$			1	2	3	dB
$V_p$	Total signal level	Allowed interposed AC-voltage across the line, peak value				
		$I_{Line} \geq 10 \text{ mA}$			1.45	Vpeak
		$I_{Line} \geq 20 \text{ mA}$			1.85	Vpeak
$R_K$	Key resistance	Key circuit closed			1	kohm
$R_K$	Key resistance	Key circuit open	100			kohm
D	Total harmonic distortion				-31	dBm
H	Harmonics	300-3400 Hz			-33	dBm
		3.4-50 kHz			-33-80*	dBm
		$\geq 50 \text{ kHz}$			-80	dBm

### Functional Description

The circuit generates through digital synthesis the 8-tones which are needed for DTMF-signalling on a telephone line. A 3.5795 MHz TV crystal is used as frequency standard.

The crystal oscillator frequency is divided first by 4 and then by 7 for the low frequency group and by 5 for the high frequency group. The generation of the two tones which signify the specific digit is activated by connecting one input in each group to ground. Each tone is generated digitally with I<sup>2</sup>L logic. Each digital signal is fed into a 4-bit digital/analog converter that generates a sinusshaped signal 15 steps in amplitude and 30 steps in time for each cycle.

The steplength is varied for each step but also for each tone to obtain a sinus signal with as low overtone content as possible and using as simple filter as possible. The result is according to the CEPT specification.

Reference to the signal amplitude is a band gap-reference voltage of 1.22 V. The additive signal from the two D/A converters is filtered in an internal filter and after that in an external filter stage.

The power amplifier consists of circuits for quick start up and defined DC-characteristic for 8–100 mA current. It also has an active output impedance to give correct matching to the line within frequency range of 300–3400 Hz. The circuit is powered by current generators from the +line. The keyboard is sensed by DC-currents which gives good possibilities to

use effective RFI suppression methods.

If two or more keys are pressed, no tones other than the basic eight are generated.

All tones can be generated separately.

There are two possible methods.

When testing a circuit without a keyboard, only the input for the present tone is connected to the ground (pin 3).

When testing a circuit with a keyboard, two buttons in the same row or column are pushed and the tone for that row or column is generated.

The absolute signal level can be adjusted with R<sub>2</sub>, but there is no need for individual adjustment on every circuit.

The relative signal level, high-low, is internally determined to 2 dB ± 1 dB.

The signal level is stabilized against variations in temperature and line current.

Pause time and signal time are determined externally from the keyboard.

Pin 10 is for fast start up.

Component function (figure 8):

- R<sub>1</sub>: Increases the DC-voltage over the circuit (if wanted)
- R<sub>2</sub>: Signal level
- R<sub>3</sub>/C<sub>1</sub>: Low pass filter
- R<sub>4</sub>: DC-characteristic, output impedance
- R<sub>5</sub>: Decreases the DC-voltage over the circuit if wanted (re-

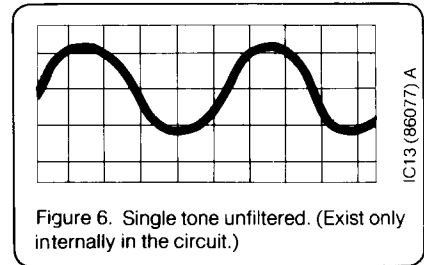

Figure 6. Single tone unfiltered. (Exist only internally in the circuit.)

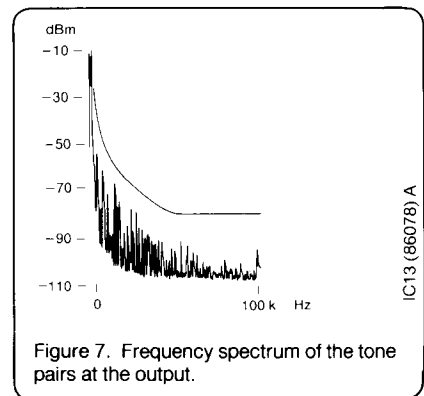
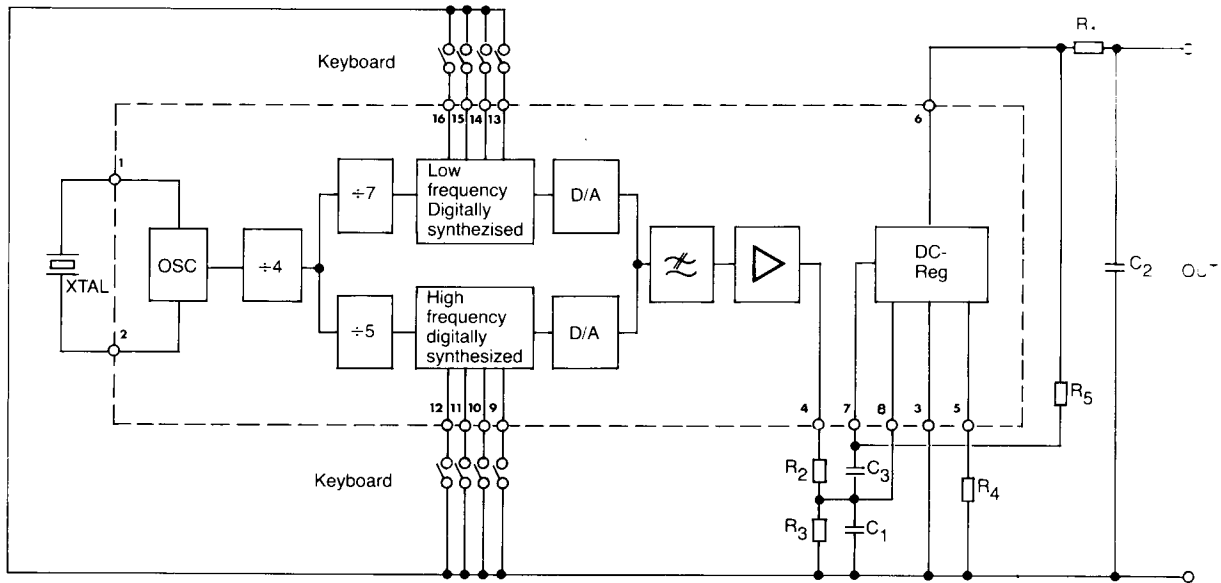

Figure 7. Frequency spectrum of the tone pairs at the output.

duces allowed interposted AC voltage across the line)

- C<sub>2</sub>: Radio frequency suppression and part of impedance to the line. A decrease to 15 nF gives an optimum balance to 600 ohm. An increase to 33 nF gives an optimum balance to 900 ohm/30 nF.
- C<sub>3</sub>: Coupling capacitor and filter for DC stabilization



- $R_1 = 0$
  - $R_2 = 7.87 \text{ Kohm} \pm 2\%$
  - $R_3 = 1 \text{ Kohm} \pm 2\%$
  - $R_4 = 47 \text{ ohm} \pm 2\% \text{ 1 W}$
  - $R_5 = \infty$
  - $C_1 = 68 \text{ nF} \pm 10\%$
  - $C_2 = 22 \text{ nF} \pm 10\%$
  - $C_3 = 0.47 \text{ } \mu\text{F} \pm 10\%$
  - 9 = 1633 Hz
  - 10 = 1477 Hz
  - 11 = 1336 Hz
  - 12 = 1209 Hz
  - 13 = 941 Hz
  - 14 = 852 Hz
  - 15 = 770 Hz
  - 16 = 697 Hz
- XTAL  $R_s \leq 250 \text{ ohm}$   
 $f = 3.5795 \text{ MHz}$

Figure 8. Pin configuration and external components

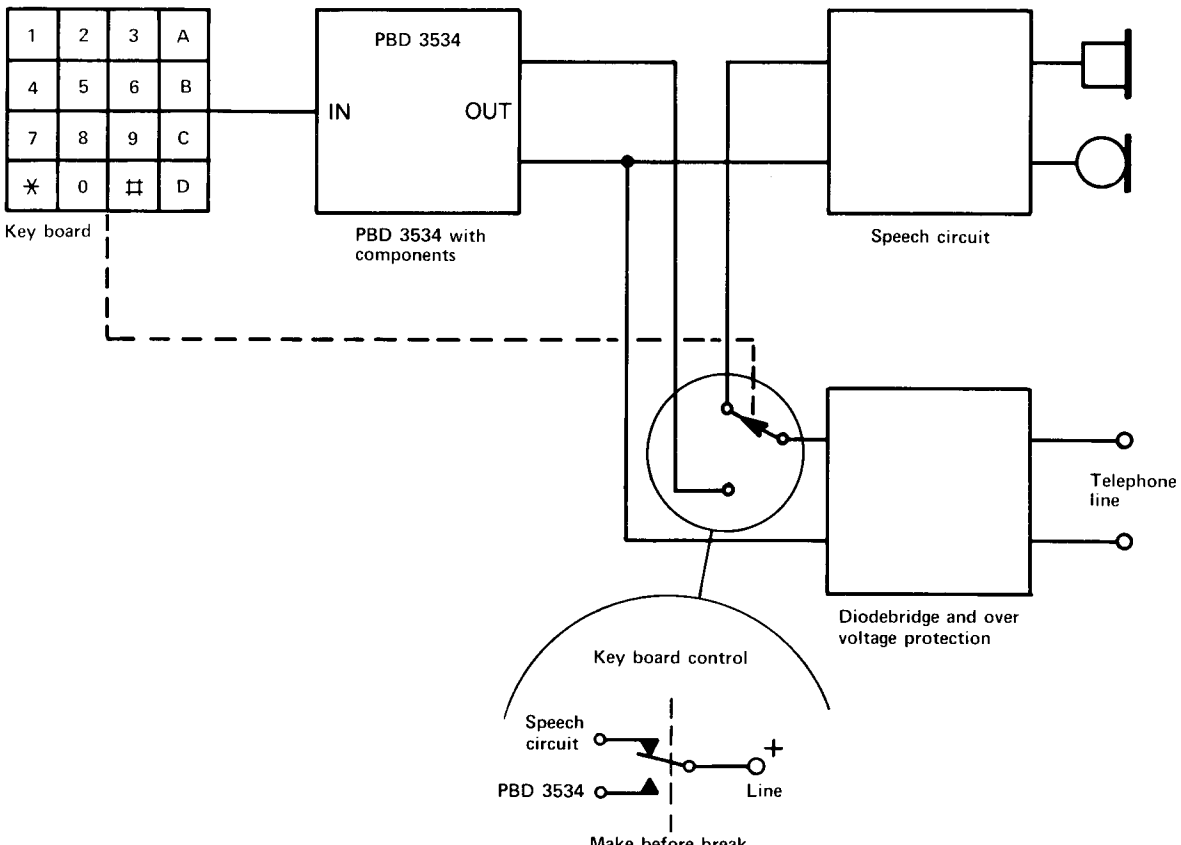

IC13 (85222) A

IC13 (86110) A

Symbol	Parameter	Condition	Min	Typ	Max	Unit
Tf	Frequency Low	$f_{osc} = 3.5795 \text{ MHz}$				
		$f_1 = 697 \text{ Hz}$	-1	-0.32	+1	%
		$f_2 = 770 \text{ Hz}$	-1	+0.02	+1	%
		$f_3 = 852 \text{ Hz}$	-1	+0.03	+1	%
		$f_4 = 941 \text{ Hz}$	-1	-0.11	+1	%
	High	$f_5 = 1209 \text{ Hz}$	-1	-0.03	+1	%
		$f_6 = 1336 \text{ Hz}$	-1	-0.03	+1	%
		$f_7 = 1477 \text{ Hz}$	-1	-0.68	+1	%
		$f_8 = 1633 \text{ Hz}$	-1	-0.36	+1	%

\* Single tone distortion is less than  $(-33 - 40 \log \frac{f}{3400}) \text{ dBm}$

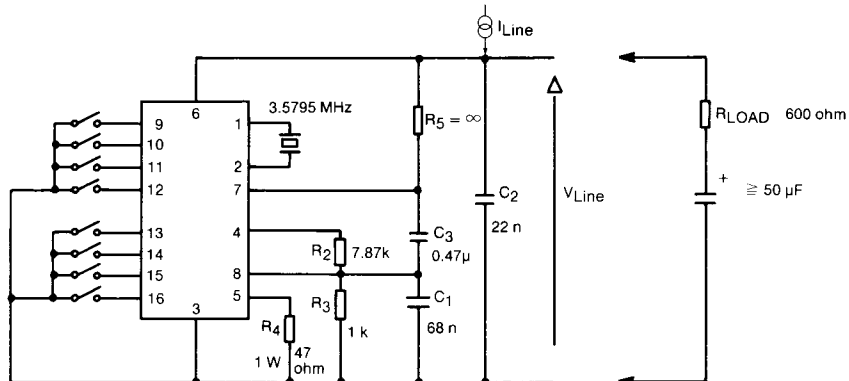

Figure 1. Test circuit

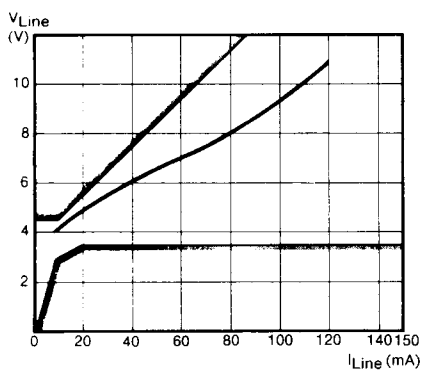

Figure 2. DC characteristics

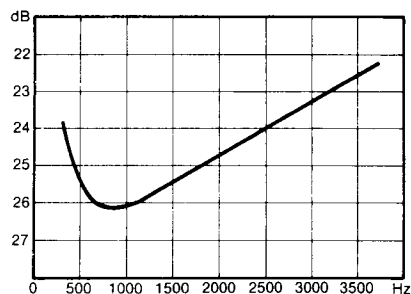
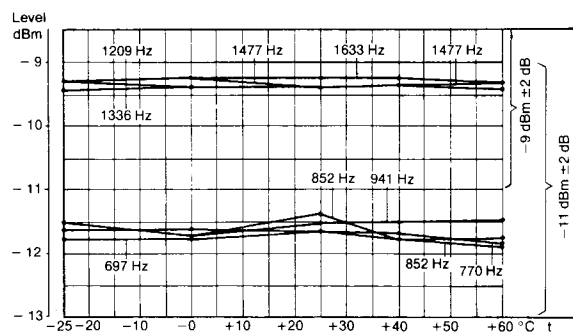
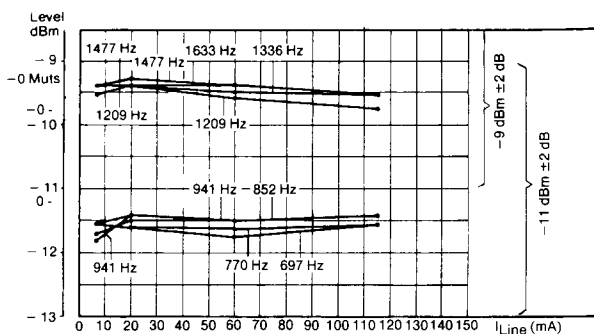

Figure 3. Return loss against 600 ohm



IC13 (85217) A

IC13 (85219) A

IC13 (85218) A

**Mechanical Data**

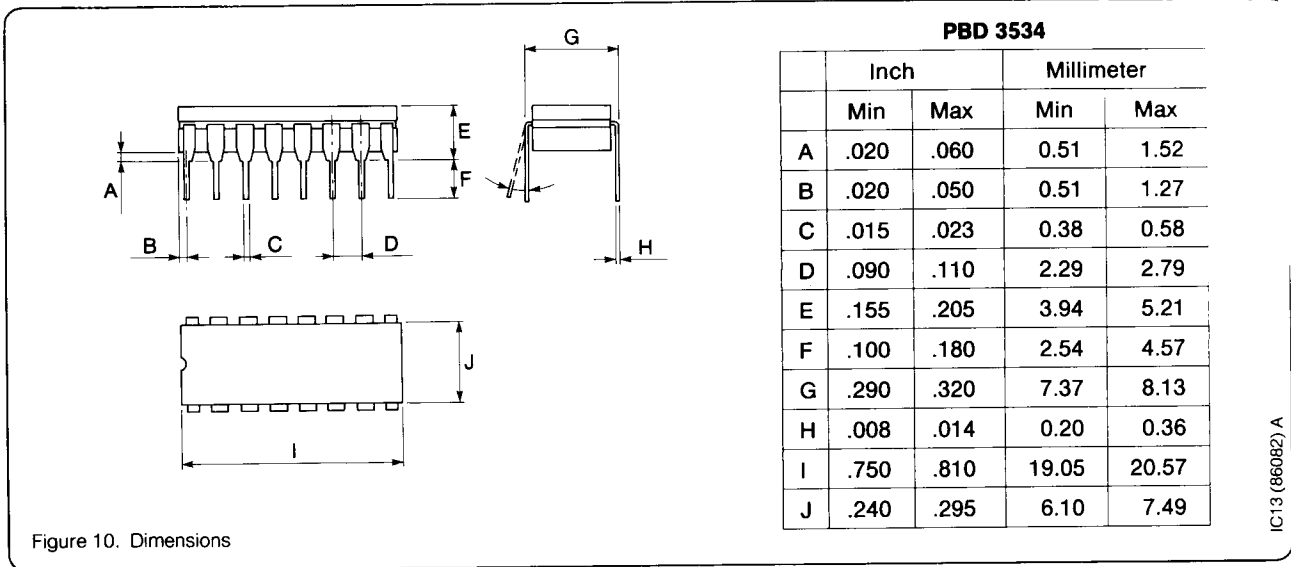

Figure 10. Dimensions

IC13 (86082) A

**Ordering information**

RIFA Order No.	Function	Encapsulation
PBD 3534	DTMF-Generator	16 Pin CERDIP

