

**Rectifier diodes
Schottky barrier**

PBYR745B, PBYR745D series

FEATURES

- Low forward volt drop
- Fast switching
- Reverse surge capability
- High thermal cycling performance
- Low thermal resistance

SYMBOL

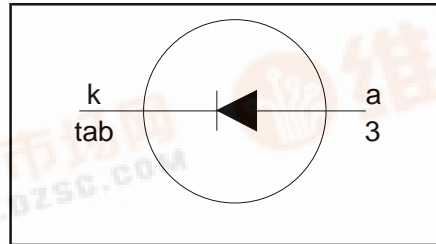

QUICK REFERENCE DATA

| |
|-----------------------------------|
| $V_R = 40\text{ V} / 45\text{ V}$ |
| $I_{F(AV)} = 7.5\text{ A}$ |
| $V_F \leq 0.57\text{ V}$ |

GENERAL DESCRIPTION

Schottky rectifier diodes in a surface mounting plastic envelope. Intended for use as output rectifiers in low voltage, high frequency switched mode power supplies.

The PBYR745B series is supplied in the SOT404 surface mounting package.
The PBYR745D series is supplied in the SOT428 surface mounting package.

PINNING

| PIN | DESCRIPTION |
|-----|----------------------|
| 1 | no connection |
| 2 | cathode ¹ |
| 3 | anode |
| tab | cathode |

SOT404

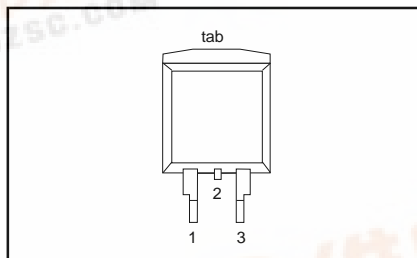

SOT428

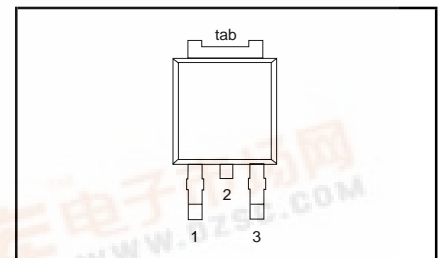

LIMITING VALUES

Limiting values in accordance with the Absolute Maximum System (IEC 134)

| SYMBOL | PARAMETER | CONDITIONS | MIN. | MAX. | | UNIT |
|-------------|---------------------------------------|---|------|------------|------------|------|
| | | | | 40B 40D | 45B 45D | |
| V_{RRM} | Peak repetitive reverse voltage | | - | 40 | 45 | V |
| V_{RWM} | Working peak reverse voltage | | - | 40 | 45 | V |
| V_R | Continuous reverse voltage | $T_{mb} \leq 114\text{ °C}$ | - | 40 | 45 | V |
| $I_{F(AV)}$ | Average rectified forward current | square wave; $\delta = 0.5$; $T_{mb} \leq 136\text{ °C}$ | - | 7.5 | | A |
| I_{FRM} | Repetitive peak forward current | square wave; $\delta = 0.5$; $T_{mb} \leq 136\text{ °C}$ | - | 15 | | A |
| I_{FSM} | Non-repetitive peak forward current | $t = 10\text{ ms}$ PBYR7..B | - | 135 | | A |
| | | $t = 8.3\text{ ms}$ | - | 150 | | A |
| | | $t = 10\text{ ms}$ PBYR7..D | - | 100 | | A |
| | | $t = 8.3\text{ ms}$ | - | 110 | | A |
| I_{RRM} | Peak repetitive reverse surge current | sinusoidal; $T_j = 125\text{ °C}$ prior to surge; with reapplied $V_{RRM(max)}$ pulse width and repetition rate limited by T_{jmax} | - | 1 | | A |
| T_j | Operating junction temperature | | - | 150 | | °C |
| | Storage temperature | | -65 | 175 | | °C |

1. It is not possible to make connection to pin 2 of the SOT404 or SOT428 package.



Rectifier diodes
Schottky barrier

PBYR745B, PBYR745D series

THERMAL RESISTANCES

| SYMBOL | PARAMETER | CONDITIONS | MIN. | TYP. | MAX. | UNIT |
|----------------|--|---|------|------|------|------|
| $R_{th\ j-mb}$ | Thermal resistance junction to mounting base | pcb mounted, minimum footprint, FR4 board | - | - | 3 | K/W |
| $R_{th\ j-a}$ | Thermal resistance junction to ambient | | - | 50 | - | K/W |

ELECTRICAL CHARACTERISTICS

$T_j = 25\text{ °C}$ unless otherwise specified

| SYMBOL | PARAMETER | CONDITIONS | MIN. | TYP. | MAX. | UNIT |
|--------|----------------------|---|------|------|------|------|
| V_F | Forward voltage | $I_F = 7.5\text{ A}; T_j = 125\text{ °C}$ | - | 0.45 | 0.57 | V |
| | | $I_F = 15\text{ A}; T_j = 125\text{ °C}$ | - | 0.65 | 0.72 | V |
| | | $I_F = 15\text{ A}$ | - | 0.64 | 0.84 | V |
| I_R | Reverse current | $V_R = V_{RWM}$ | - | 0.13 | 1 | mA |
| | | $V_R = V_{RWM}; T_j = 100\text{ °C}$ | - | 17 | 22 | mA |
| C_d | Junction capacitance | $V_R = 5\text{ V}; f = 1\text{ MHz}; T_j = 25\text{ °C to }125\text{ °C}$ | - | 270 | - | pF |

Rectifier diodes
Schottky barrier

PBYR745B, PBYR745D series

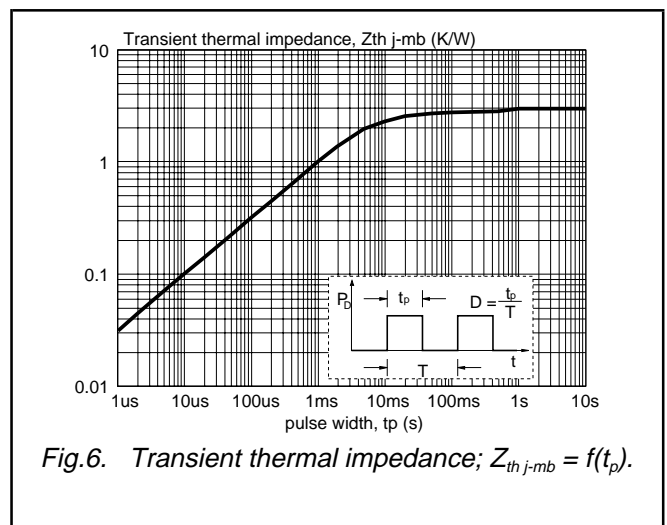
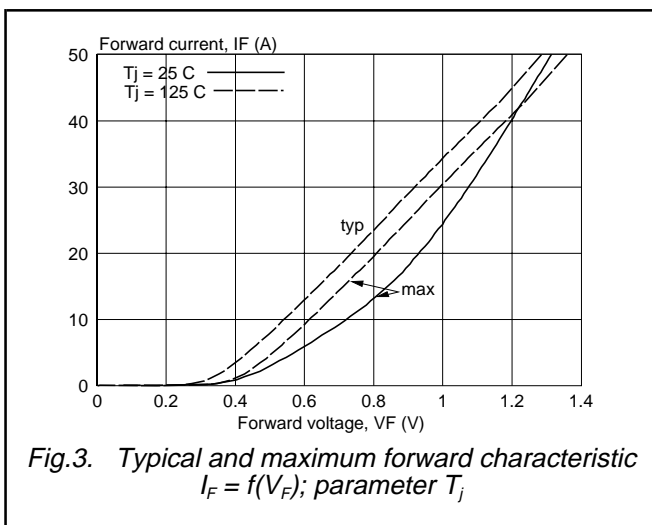
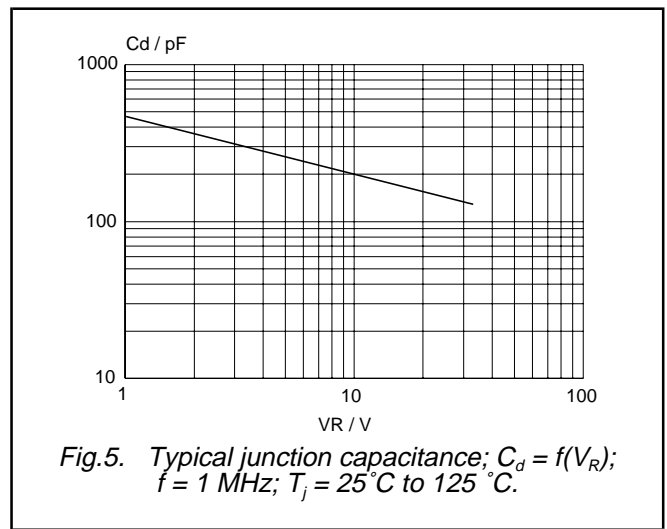
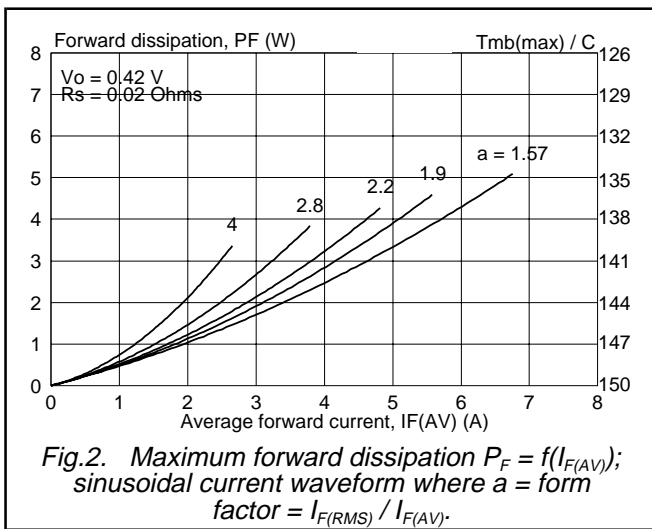
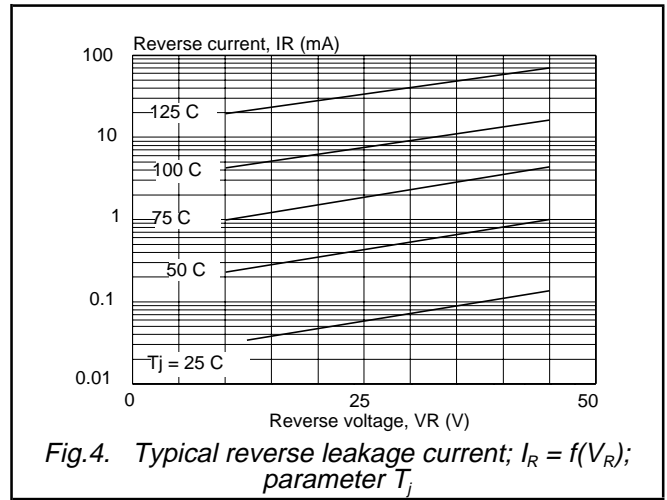
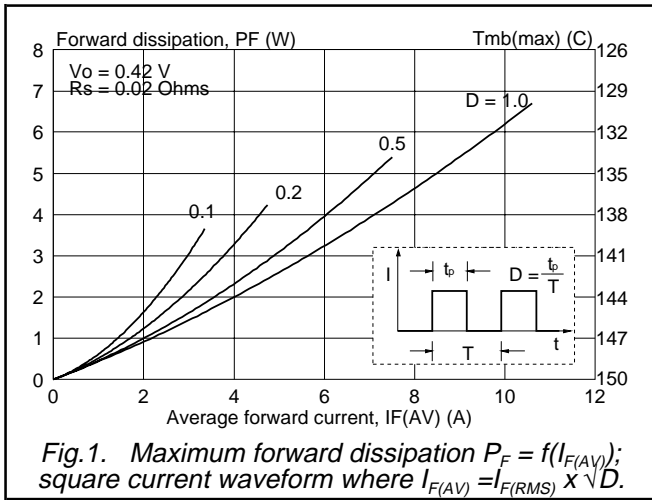

Rectifier diodes
Schottky barrier

PBYR745B, PBYR745D series

MECHANICAL DATA

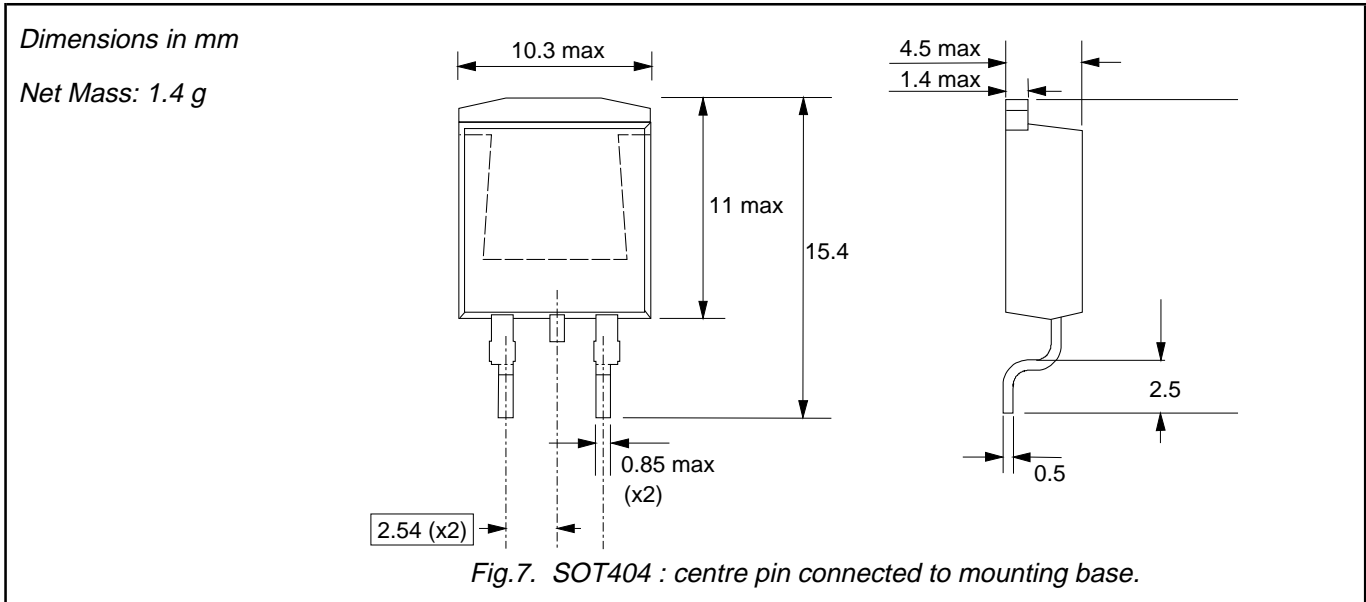

MOUNTING INSTRUCTIONS

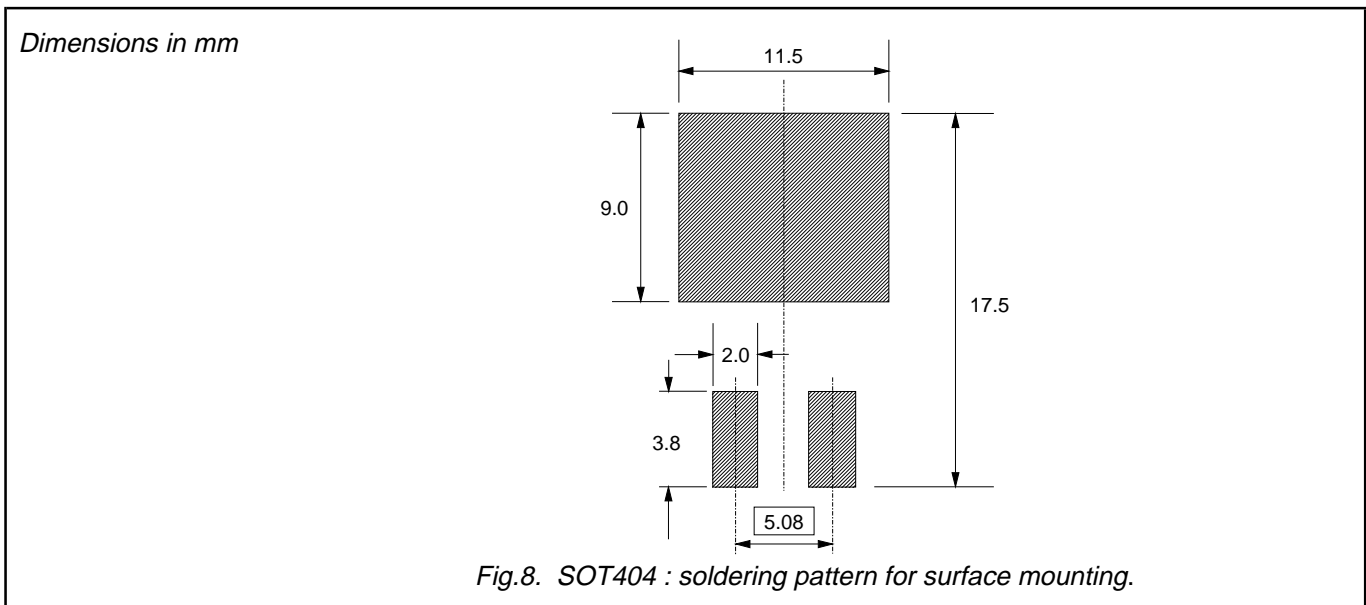

Notes

1. Observe the general handling precautions for electrostatic-discharge sensitive devices (ESDs) to prevent damage to MOS gate oxide.
2. Epoxy meets UL94 V0 at 1/8".

Rectifier diodes
Schottky barrier

PBYR745B, PBYR745D series

MECHANICAL DATA

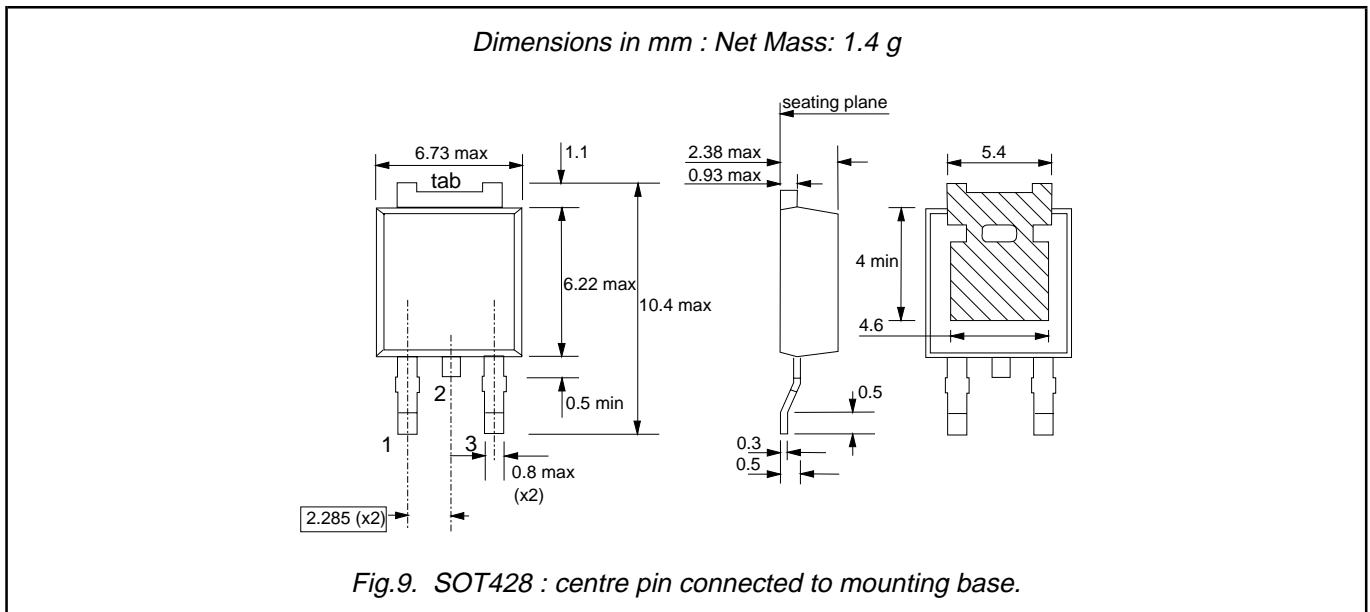

MOUNTING INSTRUCTIONS

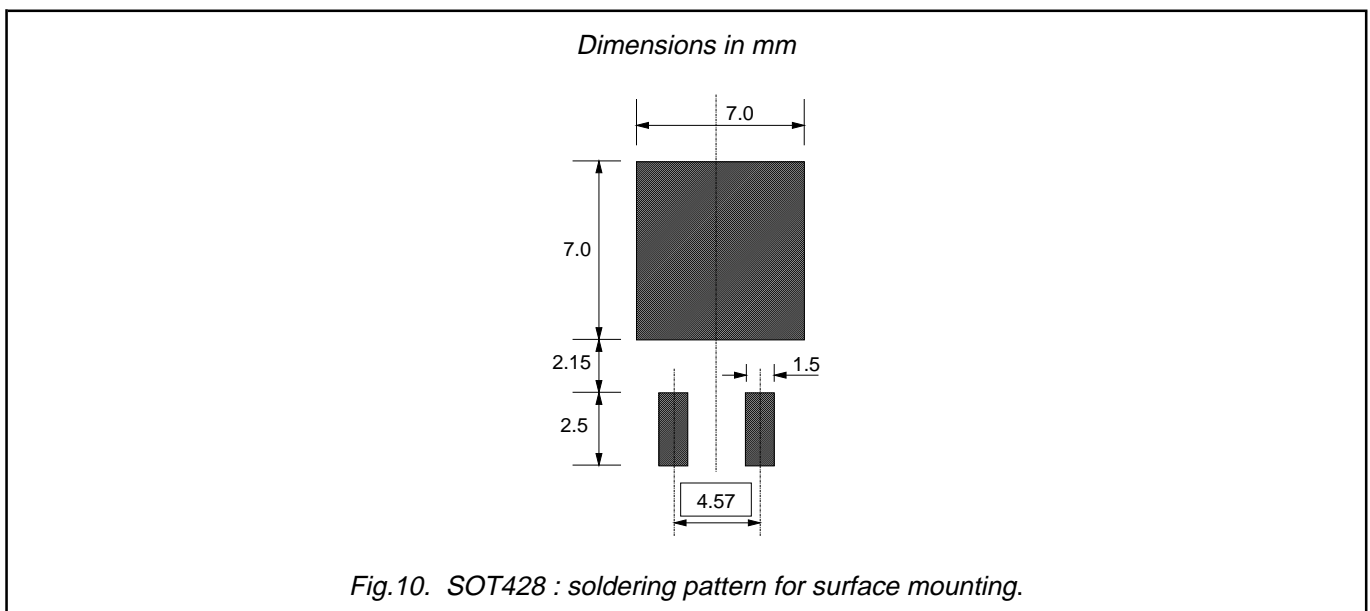

Notes

1. Observe the general handling precautions for electrostatic-discharge sensitive devices (ESDs) to prevent damage to MOS gate oxide.
2. Epoxy meets UL94 V0 at 1/8".

Rectifier diodes
Schottky barrier

PBYR745B, PBYR745D series

DEFINITIONS

| | |
|--|---|
| Data sheet status | |
| Objective specification | This data sheet contains target or goal specifications for product development. |
| Preliminary specification | This data sheet contains preliminary data; supplementary data may be published later. |
| Product specification | This data sheet contains final product specifications. |
| Limiting values | |
| Limiting values are given in accordance with the Absolute Maximum Rating System (IEC 134). Stress above one or more of the limiting values may cause permanent damage to the device. These are stress ratings only and operation of the device at these or at any other conditions above those given in the Characteristics sections of this specification is not implied. Exposure to limiting values for extended periods may affect device reliability. | |
| Application information | |
| Where application information is given, it is advisory and does not form part of the specification. | |
| © Philips Electronics N.V. 1998 | |
| All rights are reserved. Reproduction in whole or in part is prohibited without the prior written consent of the copyright owner. | |
| The information presented in this document does not form part of any quotation or contract, it is believed to be accurate and reliable and may be changed without notice. No liability will be accepted by the publisher for any consequence of its use. Publication thereof does not convey nor imply any license under patent or other industrial or intellectual property rights. | |

LIFE SUPPORT APPLICATIONS

These products are not designed for use in life support appliances, devices or systems where malfunction of these products can be reasonably expected to result in personal injury. Philips customers using or selling these products for use in such applications do so at their own risk and agree to fully indemnify Philips for any damages resulting from such improper use or sale.