

# PC410

## Compact, Surface Mount Ultra-high Speed Response OPIC Photocoupler

### ■ Features

1. Mini-flat package
2. Ultra-high speed response  
( $t_{PLH}$ ,  $t_{PHL}$  : TYP. 50ns at  $R_L = 350\Omega$ )
3. Isolation voltage between input and output  
( $V_{iso}$  : 2 500 V<sub>rms</sub>)
4. Instantaneous common mode rejection  
voltage  $CM_H$  : TYP. 500V/ $\mu$ s
5. Recognized by UL(No.64380)

### ■ Applications

1. Hybrid substrate which requires high density mounting
2. Personal computers, office computers and peripheral equipment
3. Electronic musical instruments
4. Audio equipment

### ■ Package Specifications

Model No.	Package specifications	Diameter of reel	Tape width
PC410	Taping package (Net:3 000pcs.)	370 mm	12 mm
PC410T	Taping package (Net: 750pcs.)	180 mm	12 mm
PC410Z	Sleeve package (Net: 100pcs.)	-	-

### ■ Absolute Maximum Ratings

( $T_a = 25^\circ\text{C}$ )

Parameter		Symbol	Rating	Unit
Input	*1 Forward current	$I_F$	20	mA
	Reverse voltage	$V_R$	5	V
	Power dissipation	P	40	mW
Output	*2 Supply voltage	$V_{CC}$	7	V
	High level output voltage	$V_{OH}$	7	V
	Low level output current	$I_{OL}$	50	mA
	Output collector power dissipation	$P_O$	85	mW
*3 Isolation voltage	$V_{iso}$	2 500	$V_{rms}$	
Operating temperature		$T_{opr}$	0 to + 70	$^\circ\text{C}$
Storage temperature		$T_{stg}$	- 40 to + 125	$^\circ\text{C}$
*4 Soldering temperature	$T_{sol}$	260	$^\circ\text{C}$	

\*1  $T_a = 0$  to + 70 $^\circ\text{C}$

\*2 For 1 minute MAX.

\*3 AC for 1 minute, 40 to 60% RH. Apply the specified voltage between the whole of the electrode pins on the input side and the whole of the electrode pins on the output side.

\*4 For 10 seconds.

### ■ Outline Dimensions

(Unit : mm)

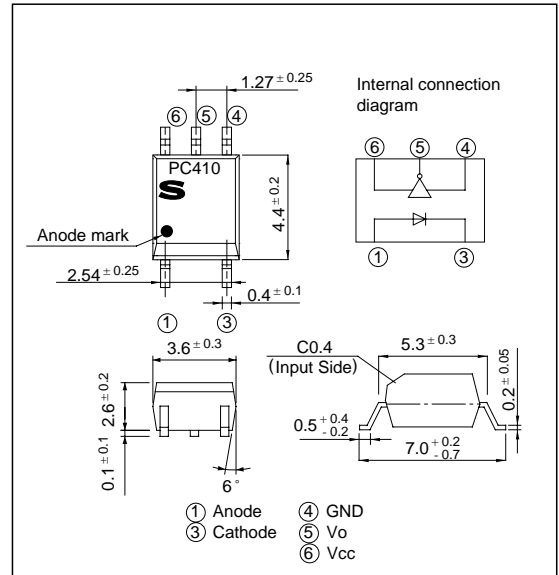

\* "OPIC" (Optical IC) is a trademark of the SHARP Corporation.

An OPIC consists of a light-detecting element and signal-processing circuit integrated onto a single chip.

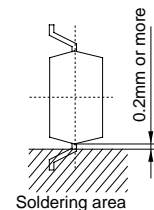

## ■ Electro-optical Characteristics

( $T_a = 0$  to  $+70^\circ\text{C}$  unless otherwise specified)

Parameter		Symbol	Conditions	MIN.	TYP.	MAX.	Unit		
Input	Forward voltage	$V_F$	$T_a = 25^\circ\text{C}, I_F = 10\text{mA}$	-	1.6	1.9	V		
	Reverse current	$I_R$	$T_a = 25^\circ\text{C}, V_R = 5\text{V}$	-	-	10	$\mu\text{A}$		
	Terminal capacitance	$C_t$	$T_a = 25^\circ\text{C}, V = 0, f = 1\text{MHz}$	-	60	150	pF		
Output	Low level output voltage	$V_{OL}$	$I_{OL} = 13\text{mA}, V_{CC} = 5.5\text{V}, I_F = 5\text{mA}$	-	0.4	0.6	V		
	High level output current	$I_{OH}$	$V_{CC} = V_O = 5.5\text{V}, I_F = 250\text{mA}$	-	2	250	$\mu\text{A}$		
	Low level supply current	$I_{CCL}$	$V_{CC} = 5.5\text{V}, I_F = 10\text{mA}$	-	13	18	mA		
	High level supply current	$I_{CCH}$	$V_{CC} = 5.5\text{V}, I_F = 0$	-	7	15	mA		
Transfer characteristics	“H→L” threshold input current		$I_{FHL}$	$V_{CC} = 5\text{V}, V_O = 0.8\text{V}, R_L = 350\Omega$	-	2.5	5	mA	
	Isolation resistance		$R_{ISO}$	$T_a = 25^\circ\text{C}, \text{DC500V}, 40$ to $60\% \text{RH}$	$5 \times 10^{10}$	$10^{11}$	-	$\Omega$	
	Floating capacitance		$C_f$	$T_a = 25^\circ\text{C}, V = 0, f = 1\text{MHz}$	-	0.6	-	pF	
	Response time	“H→L” propagation delay time		$t_{PHL}$	$T_a = 25^\circ\text{C}$ $V_{CC} = 5\text{V}, I_F = 7.5\text{mA}$ $R_L = 350\Omega, C_L = 15\text{pF}$ Fig. 1	-	50	120	ns
		“L→H” propagation delay time		$t_{PLH}$		-	50	120	
		Fall time		$t_f$		-	30	60	
		Rise time		$t_r$		-	30	60	
CMR	Instantaneous common mode rejection voltage “High level output”		$CM_H$	$I_F = 0$ $V_O(\text{MIN.}) = 2\text{V}$	$T_a = 25^\circ\text{C}$ $V_{CC} = 5\text{V}$ $V_{CM} = 10\text{V}(\text{Peak})$	100	500	-	V/ $\mu\text{s}$
	Instantaneous common mode rejection voltage “Low level output”		$CM_L$	$I_F = 5\text{mA}$ $V_O(\text{MAX.}) = 0.8\text{V}$	$R_L = 350\Omega$ Fig. 2	- 100	- 500	-	

Note ) All typical values : at  $T_a = 25^\circ\text{C}, V_{CC} = 5\text{V}$

Each characteristics shall be measured under opaque condition.

## ■ Recommended Operation Conditions

Parameter	Symbol	MIN.	MAX.	Unit
Low level input current	$I_{FL}$	0	250	$\mu\text{A}$
High level input current	$I_{FH}$	7	15	mA
Supply voltage	$V_{CC}$	4.5	5.5	V
Fanout (TTL load)	N	-	8	-
Operating temperature	$T_{opr}$	0	70	$^\circ\text{C}$

Connect a by-pass ceramic capacitor (0.01 to 0.1  $\mu\text{F}$ ) between  $V_{CC}$  and GND at the position within 1cm from lead pin.

Fig. 1 Test Circuit for  $t_{PHL}$ ,  $t_{PLH}$ ,  $t_r$  and  $t_f$

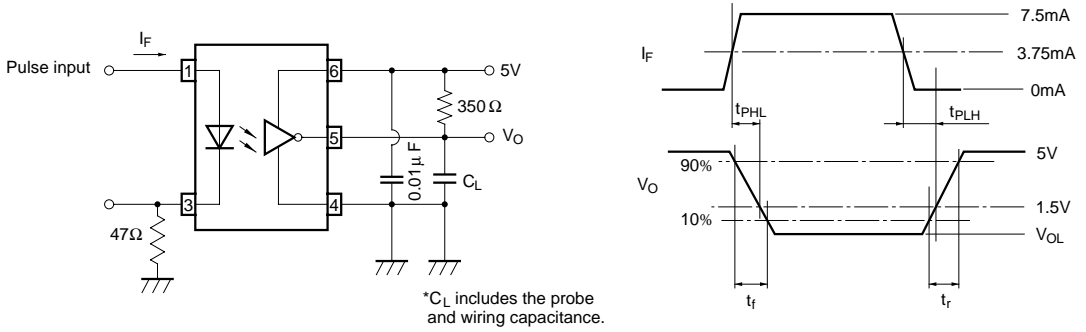

Fig. 2 Test Circuit for Instantaneous Common Mode Rejection Voltage

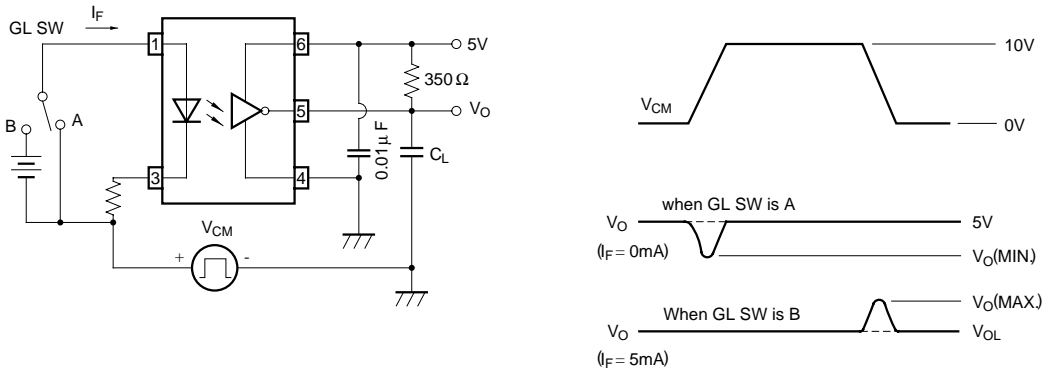

Fig. 3 Collector Power Dissipation vs. Ambient Temperature

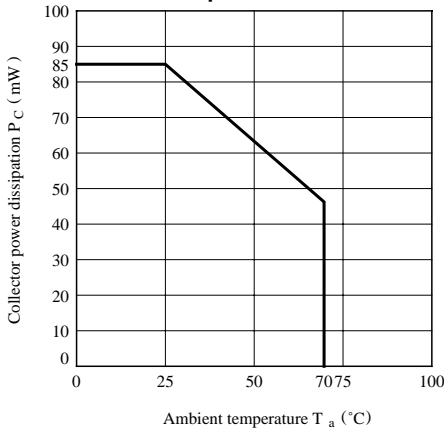
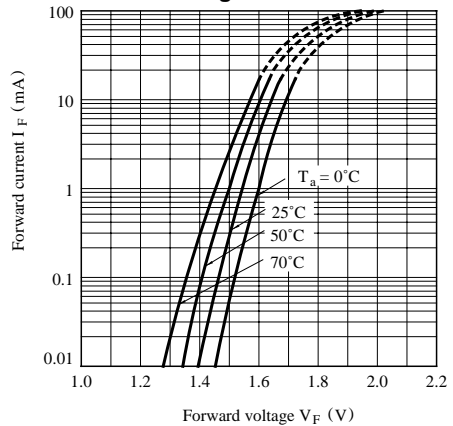
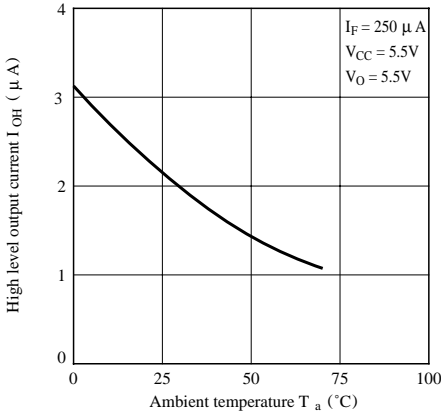

Fig. 4 Forward Current vs. Forward Voltage



**Fig. 5 High Level Output Current vs. Ambient Temperature**



**Fig. 6 Low Level Output Voltage vs. Ambient Temperature**

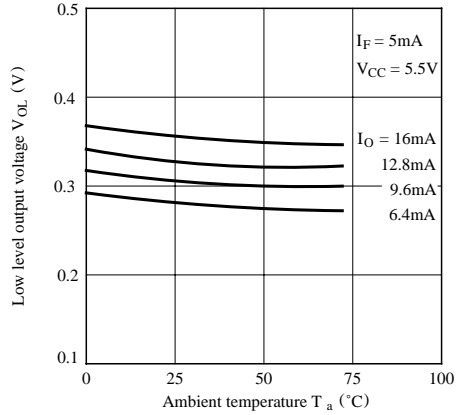

**Fig. 7-a Output Voltage vs. Forward Current**

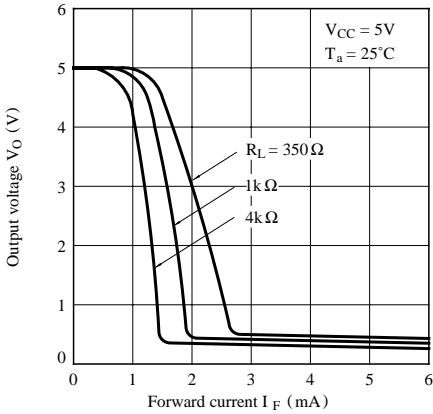

**Fig. 7-b Output Voltage vs. Forward Current (Ambient Temp. Characteristics)**

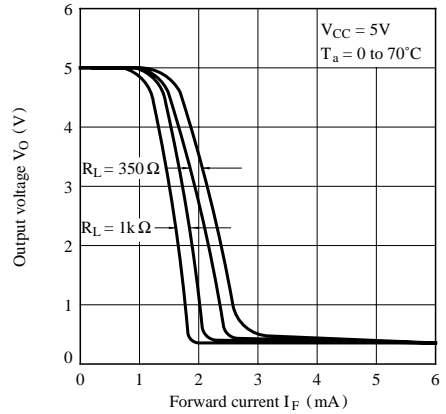

**Fig. 8 Propagation Delay Time vs. Forward Current**

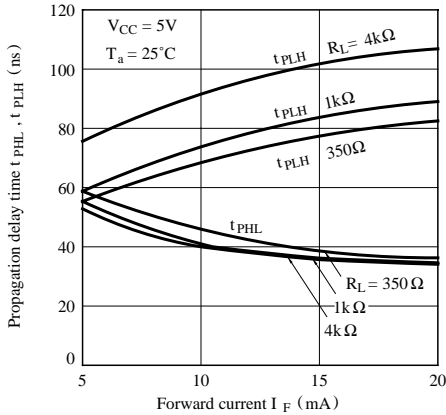

**Fig. 9 Propagation Delay Time vs. Ambient Temperature**

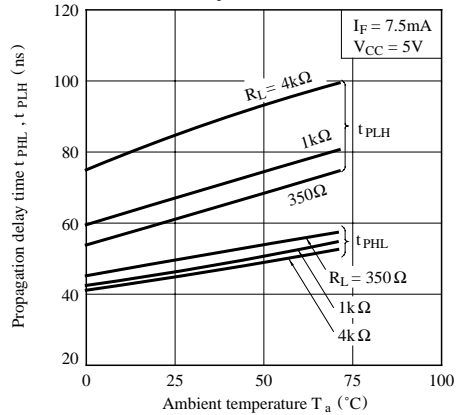

**Fig.10 Rise Time, Fall Time vs. Ambient Temperature**

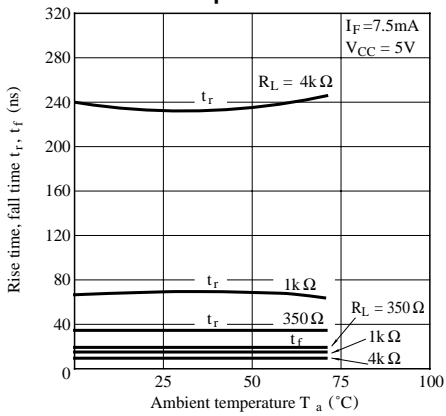

### ■ Precautions for Use

- (1) Handle this product the same as with other integrated circuits against static electricity.
- (2) As for other general cautions, refer to the chapter "Precautions for Use."