

# PC930 Series

## Digital Output, High Sensitivity Type OPIC Photocoupler

### ■ Features

- High sensitivity  
( $I_{FLH}$ ,  $I_{FHL}$  : MAX. 1mA)
- TTL and LSTTL compatible output
- Operating supply voltage range  
( $V_{CC}$  : 4.5 to 15V, **PC930/PC931/PC932/PC933**)
- Various output forms  
(Open collector output, pull-up resistor built-in type, totem pole output)
- Low output current dissipation  
( $I_{CCL}$  : MAX. 3.8mA)
- High isolation voltage between input and output ( $V_{ISO}$  : 5 000V<sub>rms</sub>)
- Recognized by UL, file No. E64380

### ■ Model Line-up

	Open collector output type	Pull-up resistor built-in type	Totem pole output type
Low active	<b>PC930</b>	<b>PC932</b>	<b>PC934</b>
High active	<b>PC931</b>	<b>PC933</b>	<b>PC935</b>

### ■ Applications

- Computer terminals
- High speed line receivers
- Interfaces with various data transmission equipment

### ■ Absolute Maximum Ratings

Parameter		Symbol	Rating	Unit	
Input	Forward current	$I_F$	20	mA	
	*1 Peak forward current	$I_{FM}$	1	A	
	Reverse voltage	$V_R$	6	V	
	Power dissipation	P	70	mW	
Output	Supply voltage	$V_{CC}$	PC930/PC931 PC932/PC933	- 0.5 to 16.0	V
			PC934/PC935	- 0.5 to 7.0	
			High level output voltage	PC930/PC931	
	High level output current	PC934/PC935	$I_{OH}$	- 800	$\mu$ A
	Low level output current	$I_{OL}$	50	mA	
	Power dissipation	$P_O$	150	mW	
Total power dissipation		$P_{tot}$	170	mW	
*2 Isolation voltage		$V_{iso}$	5 000	V <sub>rms</sub>	
Operating temperature		$T_{opr}$	- 25 to + 85	°C	
Storage temperature		$T_{stg}$	- 40 to + 125	°C	
*3 Soldering temperature		$T_{sol}$	260	°C	

### ■ Outline Dimensions

(Unit : mm)

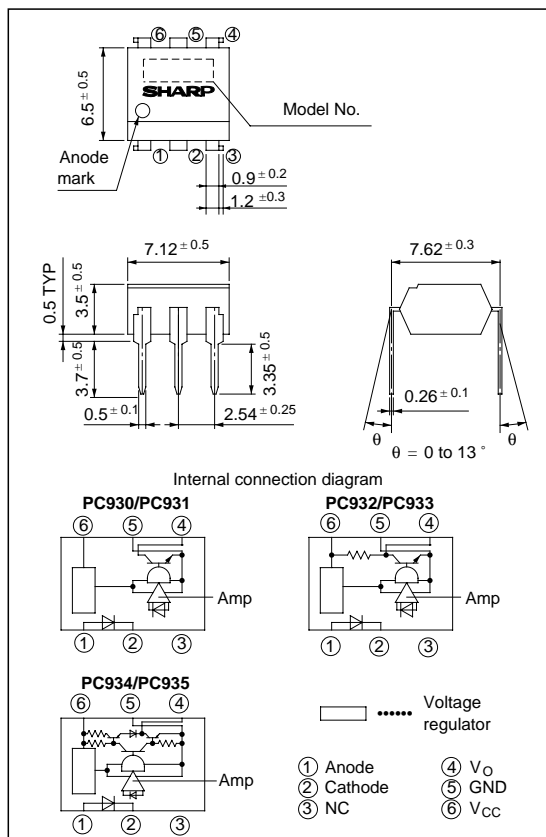

\* "OPIC" (Optical IC) is a trademark of the SHARP Corporation.  
An OPIC consists of a light-detecting element and signal-processing circuit integrated onto a single chip.

\*1 Pulse width  $\leq 100 \mu$ s

Duty ratio : 0.001

\*2 40 to 60% RH,

AC for 1 minute

\*3 For 10 seconds

## ■ Electro-optical Characteristics

(Ta = 0 to + 70°C unless otherwise specified.)

Parameter		Symbol	Conditions	MIN.	TYP.	MAX.	Unit			
Input	Forward voltage	$V_F$	$I_F = 2\text{mA}$	-	1.1	1.4	V			
			$I_F = 0.1\text{mA}$	0.55	0.95	-	V			
	Reverse current	$I_R$	Ta = 25°C, $V_R = 3\text{V}$	-	-	10	μA			
Terminal capacitance		$C_t$	Ta = 25°C, $V = 0$ , $f = 1\text{kHz}$	-	30	250	pF			
Output	Operating supply voltage	$V_{CC}$	-	4.5	-	15	V			
				4.5	-	5.5	V			
	Low level output voltage	$V_{OL}$	$I_{OL} = 16\text{mA}$ , $V_{CC} = 5\text{V}$ , $I_F = 1\text{mA}$ $I_{OL} = 16\text{mA}$ , $V_{CC} = 5\text{V}$ , $I_F = 0$ $I_{OL} = 16\text{mA}$ , $V_{CC} = 4.5\text{V}$ , $I_F = 1\text{mA}$ $I_{OL} = 16\text{mA}$ , $V_{CC} = 4.5\text{V}$ , $I_F = 0$	-	0.15	0.4	V			
								PC930/PC932		
								PC931/PC933		
								PC934		
	High level output voltage	$V_{OH}$	$V_{CC} = 5\text{V}$ , $I_F = 0$ $V_{CC} = 5\text{V}$ , $I_F = 1\text{mA}$ $V_{CC} = 4.5\text{V}$ , $I_F = 0$ , $I_{OH} = -400\text{μA}$ $V_{CC} = 4.5\text{V}$ , $I_F = 1\text{mA}$ , $I_{OH} = -400\text{μA}$	3.5	-	-	V			
								PC932		
				PC933						
				PC934						
	High level output current	$I_{OH}$	$V_{CC} = V_O = 15\text{V}$ , $I_F = 0$ $V_{CC} = V_O = 15\text{V}$ , $I_F = 1\text{mA}$	-	-	100	μA			
				PC930	-	-	100	μA		
Low level supply current	$I_{CCL}$	$V_{CC} = 5\text{V}$ , $I_F = 1\text{mA}$ $V_{CC} = 5\text{V}$ , $I_F = 0$ $V_{CC} = 5\text{V}$ , $I_F = 1\text{mA}$ $V_{CC} = 5\text{V}$ , $I_F = 0$	-	1.3	3.4	mA				
			PC930	-	1.3	3.4	mA			
			PC931	-	1.7	3.8	mA			
			PC932/PC934	-	1.7	3.8	mA			
High level supply current	$I_{CCH}$	$V_{CC} = 5\text{V}$ , $I_F = 0$ $V_{CC} = 5\text{V}$ , $I_F = 1\text{mA}$	-	0.7	2.2	mA				
			PC930/PC932	-	0.7	2.2	mA			
Output short circuit current	$I_{OS}$	$V_{CC} = 5\text{V}$ , $I_F = 0$ , $T = \text{Within } 1\text{ second}$ $V_{CC} = 5\text{V}$ , $I_F = 1\text{mA}$ , $T = \text{Within } 1\text{ second}$	6	17	35	mA				
			PC934	6	17	35	mA			
Transfer characteristics	*4 "High→Low" Threshold input current	$I_{FHL}$	$V_{CC} = 5\text{V}$ , $R_L = 280\text{Ω}$	-	0.5	1.0	mA			
				PC930/PC932	0.1	0.4	-	mA		
				PC934	0.1	0.4	-	mA		
	*5 "Low→High" Threshold input current	$I_{FLH}$	$V_{CC} = 5\text{V}$ , $R_L = 280\text{Ω}$	-	0.5	1.0	mA			
				PC930/PC932	-	0.5	1.0	mA		
				PC934	-	0.5	1.0	mA		
	*6 Hysteresis	$I_{FHL}/I_{FHL}$	$V_{CC} = 5\text{V}$ , $R_L = 280\text{Ω}$	-	0.8	-	-			
				PC930/PC932	-	0.8	-	-		
	Response time	Isolation resistance	$R_{ISO}$	Ta = 25°C, DC500V, 40 to 60% RH	5 x 10 <sup>10</sup>	10 <sup>11</sup>	-	Ω		
					"High→Low" propagation delay time	$t_{PHL}$	-	3	9	μs
							PC930/PC932	-	5	
					"Low→High" propagation delay time	$t_{PLH}$	$T_a = 25^\circ\text{C}$ $V_{CC} = 5\text{V}$ $I_F = 1\text{mA}$ $R_L = 280\text{Ω}$ Fig.1	-	5	
PC934								-	5	
Fall time					$t_f$	-	0.05	0.5		
Rise time	$t_r$	-	0.1	0.5						

\*4  $I_{FHL}$  represents forward current when output goes from high to low.

\*5  $I_{FLH}$  represents forward current when output goes from low to high.

\*6 Hysteresis stands for  $I_{FHL}/I_{FHL}$ .

■ Recommended Operating Conditions

Parameter	Symbol	MIN.	TYP.	MAX.	Unit	
Low level output current	$I_{OL}$	-	1.6	16	mA	
High level output current	<b>PC934/PC935</b> $I_{OH}$	-	-	- 400	$\mu$ A	
Supply voltage	<b>PC930/PC931</b> <b>PC932/PC933</b>	$V_{CC}$	4.5	5.0	15.0	V
	<b>PC934/PC935</b>		4.5	5.0	5.5	V
	Operating temperature	$T_{opr}$	0	25	70	$^{\circ}$ C

Fig. 1 Test Circuit for  $t_{PHL}$ ,  $t_{PLH}$ ,  $t_r$ ,  $t_f$

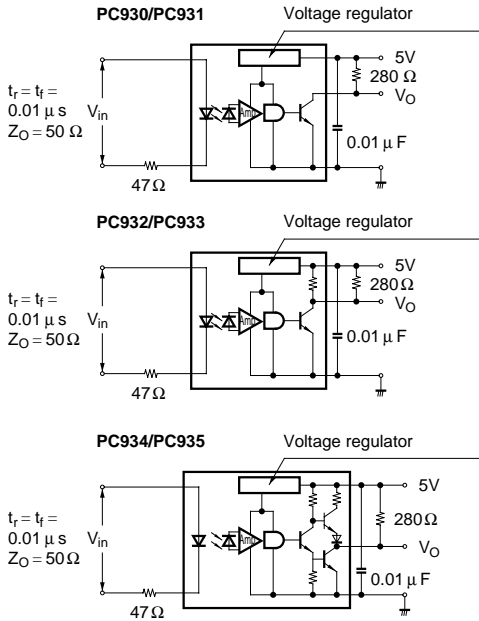

PC930/PC932/PC934

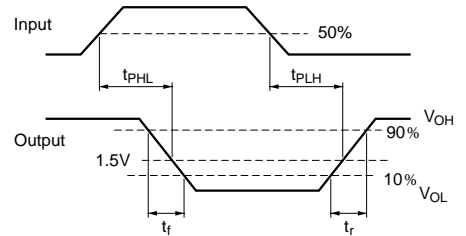

PC931/PC933/PC935

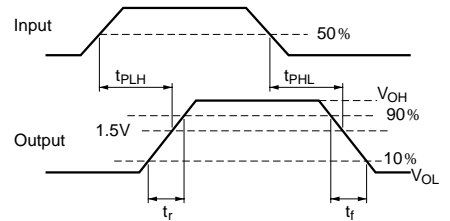

Fig. 2 Forward Current vs. Ambient Temperature

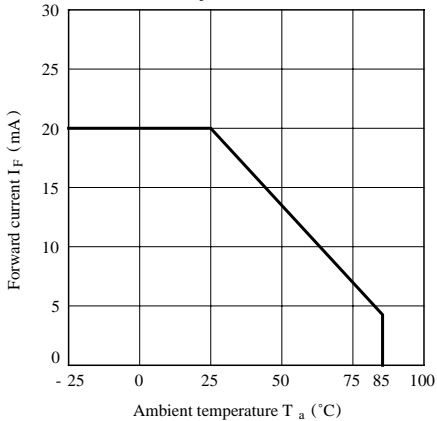

Fig. 3 Power Dissipation vs. Ambient Temperature

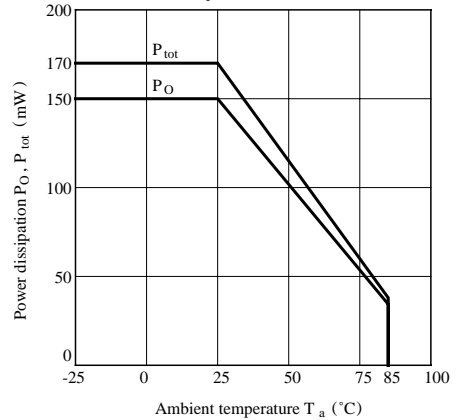

Fig. 4 Forward Current vs. Forward Voltage

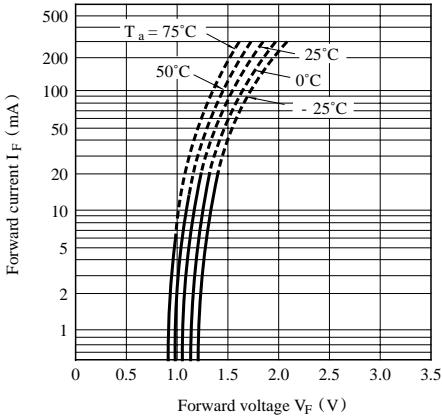

Fig. 5-a Relative Threshold Input Current vs. Supply Voltage

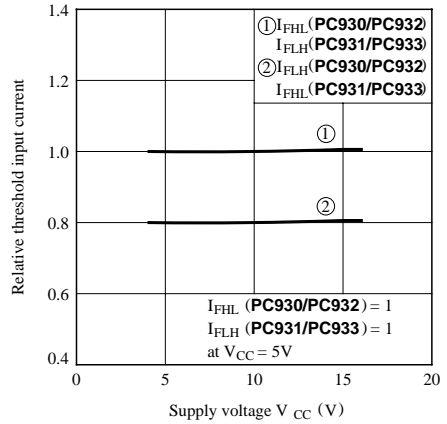

Fig. 5-b Relative Threshold Input Current vs. Supply Voltage

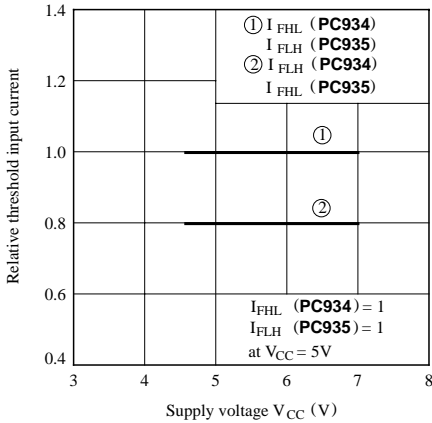

Fig. 6 Relative Threshold Input Current vs. Ambient Temperature

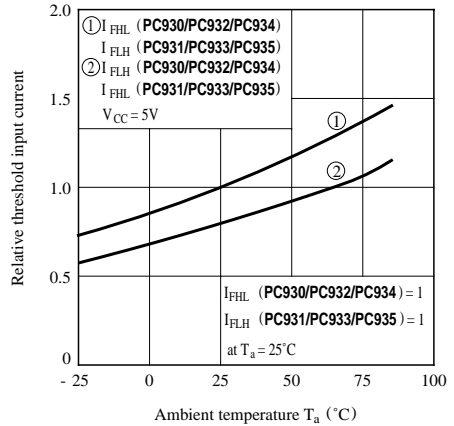

Fig. 7 Low Level Output Voltage vs. Low Level Output Current

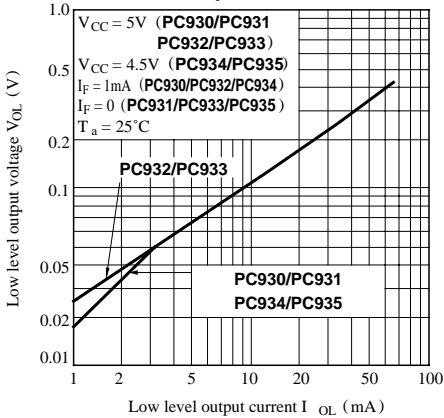
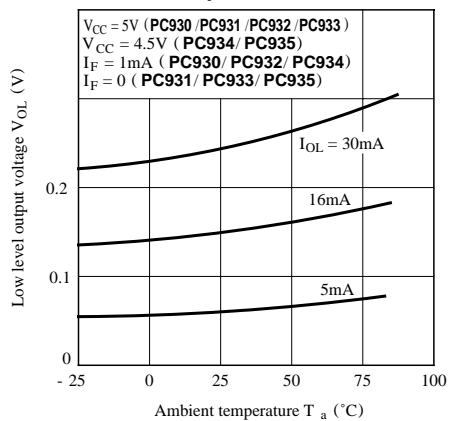
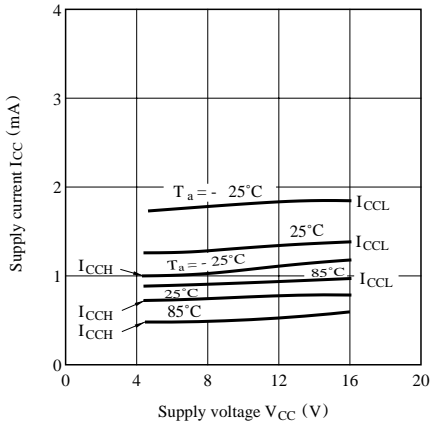

Fig. 8 Low Level Output Voltage vs. Ambient Temperature



**Fig. 9-a Supply Current vs. Supply Voltage (PC930/PC931)**



**Fig. 9-b Supply Current vs. Supply Voltage (PC932/PC933)**

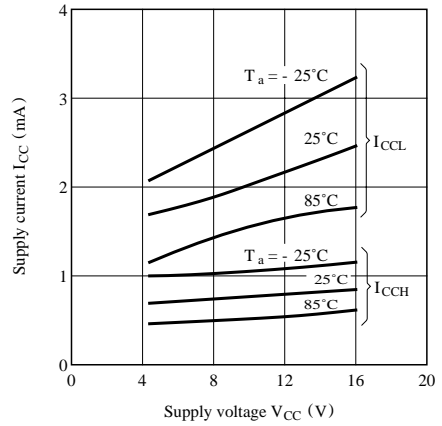

**Fig. 9-c Supply Current vs. Supply Voltage (PC934/PC935)**

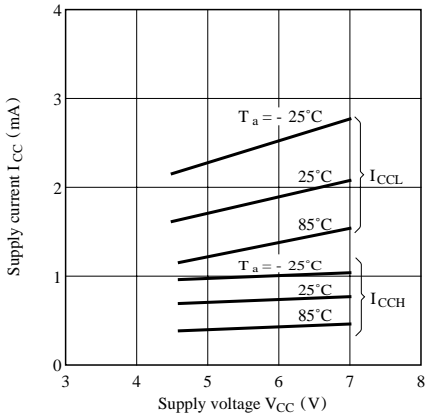

**Fig.10 Propagation Delay Time vs. Forward Current**

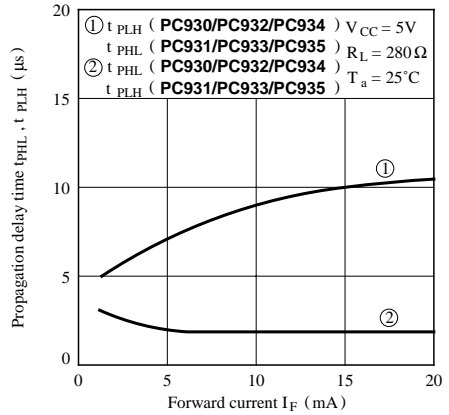

**Fig.11-a Rise Time, Fall Time vs. Load Resistance (PC930/PC931)**

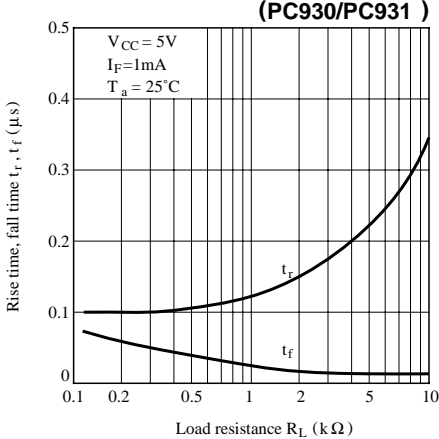

**Fig.11-b Rise Time, Fall Time vs. Load Resistance (PC932/PC933)**

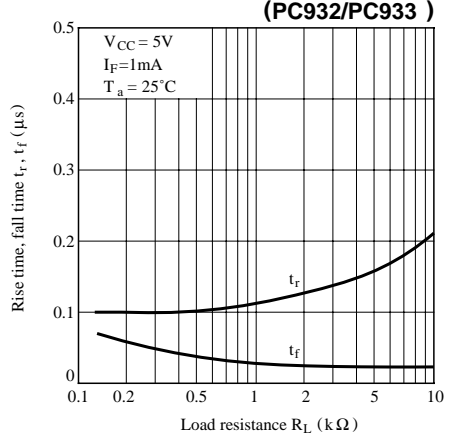
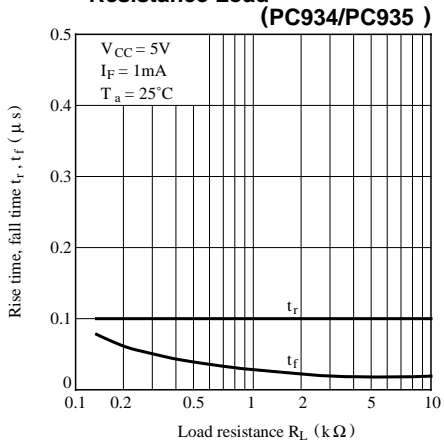

Fig.11-c Rise Time, Fall Time vs.  
Resistance Load



### ■ Precautions for Use

- (1) It is recommended that a by-pass capacitor of more than  $0.01 \mu F$  is added between  $V_{CC}$  and GND near the device in order to stabilize power supply line.
- (2) Handle this product the same as with other integrated circuits against static electricity.
- (3) As for other general cautions, refer to the chapter "Precautions for Use".