

- PCI Bus Power Management Interface Specification 1.0 Compliant
- ACPI 1.0 Compliant
- Fully Compatible With the Intel™ 430TX (Mobile Triton II) Chipset
- Packaged in a 208-Pin Low-Profile QFP (PDV) or GHK High Density Ball Grid Array (BGA)
- PCI Local Bus Specification Revision 2.2 Compliant
- 1997 PC Card™ Standard Compliant
- PC 99 Compliant
- 3.3-V Core Logic With Universal PCI Interfaces Compatible With 3.3-V and 5-V PCI Signaling Environments
- Mix-and-Match 5-V/3.3-V 16-bit PC Cards and 3.3-V CardBus Cards
- Supports Two PC Card or CardBus Slots With Hot Insertion and Removal
- Uses Serial Interface to TI™ TPS2202/2206 Dual-Slot PC Card Power Switch
- Supports Burst Transfers to Maximize Data Throughput on the PCI Bus and CardBus Bus
- Supports Parallel PCI Interrupts, Parallel ISA IRQ and Parallel PCI Interrupts, Serial ISA IRQ With Parallel PCI Interrupts, and Serial ISA IRQ and PCI Interrupts
- Pipelined Architecture Allows Greater Than 130M-Bps Throughput From CardBus-to-PCI and From PCI-to-CardBus
- Supports Up to Five General-Purpose I/Os
- Serial EEPROM Interface for Loading Subsystem ID and Subsystem Vendor ID
- Programmable Output Select for  $\overline{\text{CLKRUN}}$
- Multifunction PCI Device With Separate Configuration Space for Each Socket
- Five PCI Memory Windows and Two I/O Windows Available for Each R2 Socket
- Two I/O Windows and Two Memory Windows Available to Each CardBus Socket
- Exchangeable Card Architecture (ExCA) Compatible Registers Are Mapped in Memory and I/O Space
- Intel 82365SL-DF Register Compatible
- Supports Ring Indicate,  $\overline{\text{SUSPEND}}$ , PCI  $\overline{\text{CLKRUN}}$ , and CardBus  $\overline{\text{CCLKRUN}}$
- LED Activity Pins
- Supports PCI Bus Lock ( $\overline{\text{LOCK}}$ )
- Advanced Submicron, Low-Power CMOS Technology

**Table of Contents**

Description .....	2	CardBus Socket Registers (Functions 0 and 1) .....	103
System Block Diagram .....	3	Absolute Maximum Ratings .....	111
Terminal Assignments .....	4	Recommended Operating Conditions .....	112
Signal Name/Terminal Number Sort Tables .....	6	Electrical Characteristics .....	113
Terminal Functions .....	12	PCI Clock/Reset Timing Requirements .....	114
Power Supply Sequencing .....	22	PCI Timing Requirements .....	114
I/O Characteristics .....	22	Parameter Measurement Information .....	115
Clamping Voltages .....	22	PCI Bus Parameter Measurement Information .....	116
Peripheral Component Interconnect (PCI) Interface .....	23	PC Card Cycle Timing .....	117
PC Card Applications .....	24	Timing Requirements (Memory Cycles) .....	118
Serial Bus Interface .....	29	Timing Requirements (I/O Cycles) .....	118
Programmable Interrupt Subsystem .....	34	Switching Characteristics (Miscellaneous) .....	119
Power Management Overview .....	39	PC Card Parameter Measurement Information .....	120
PC Card Controller Programming Model .....	44	Mechanical Data .....	121
PCI Configuration Registers (Functions 0 and 1) .....	44		
ExCA Compatibility Registers (Functions 0 and 1) .....	80		



Please be aware that an important notice concerning availability, standard warranty, and use in critical applications of Texas Instruments semiconductor products and disclaimers thereto appears at the end of this data sheet.



PC Card is a trademark of Personal Computer Memory Card International Association (PCMCIA).

Intel is a trademark of Intel Corporation.

TI is a trademark of Texas Instruments Incorporated.

ADVANCE INFORMATION concerns new products in the sampling or preproduction phase of development. Characteristic data and other specifications are subject to change without notice.



# PCI1221 GHK/PDV PC CARD CONTROLLERS

SCPS042 – JULY 1998

---

## description

The TI PCI1221 is a high-performance PCI-to-PC Card controller that supports two independent card sockets compliant with the 1997 PC Card Standard. The PCI1221 provides a rich feature set that makes it the best choice for bridging between PCI and PC Cards in both notebook and desktop computers. The 1997 PC Card Standard retains the 16-bit PC Card specification defined in PCMCIA Release 2.2 and defines the new 32-bit PC Card, CardBus, capable of full 32-bit data transfers at 33 MHz. The PCI1221 supports any combination of 16-bit and CardBus PC Cards in the two sockets, powered at 5 V or 3.3 V, as required.

The PCI1221 is compliant with the PCI Local Bus Specification 2.2, and its PCI interface can act as either a PCI master device or a PCI slave device. The PCI bus mastering is initiated during CardBus PC Card bridging transactions. The PCI1221 is also compliant with the latest *PCI Bus Power Management Interface Specification*.

All card signals are internally buffered to allow hot insertion and removal without external buffering. The PCI1221 is register compatible with the Intel 82365SL-DF ExCA controller. The PCI1221 internal data path logic allows the host to access 8-, 16-, and 32-bit cards using full 32-bit PCI cycles for maximum performance. Independent buffering and a pipeline architecture provide an unsurpassed performance level with sustained bursting. The PCI1221 can also be programmed to accept fast posted writes to improve system-bus utilization.

Multiple system-interrupt signaling options are provided, including: parallel PCI, parallel ISA, serialized ISA, and serialized PCI. Furthermore, general-purpose inputs and outputs are provided for the board designer to implement sideband functions. Many other features designed into the PCI1221, such as socket activity light-emitting diode (LED) outputs, are discussed in detail throughout the design specification.

An advanced complementary metal-oxide semiconductor (CMOS) process is used to achieve low system-power consumption while operating at PCI clock rates up to 33 MHz. Several low-power modes enable the host power management system to further reduce power consumption.

Unused PCI1221 inputs must be pulled up using a 43k $\Omega$ -resistor.

## system block diagram

A simplified block diagram of the PCI1221 is provided below. The PCI interface includes all address/data and control signals for PCI protocol. The interrupt interface includes terminals for parallel PCI, parallel ISA, and serialized PCI and ISA signaling. Miscellaneous system interface terminals include multifunction terminals: SUSPEND, RI\_OUT/PME (power management control signal), and SPKROUT.

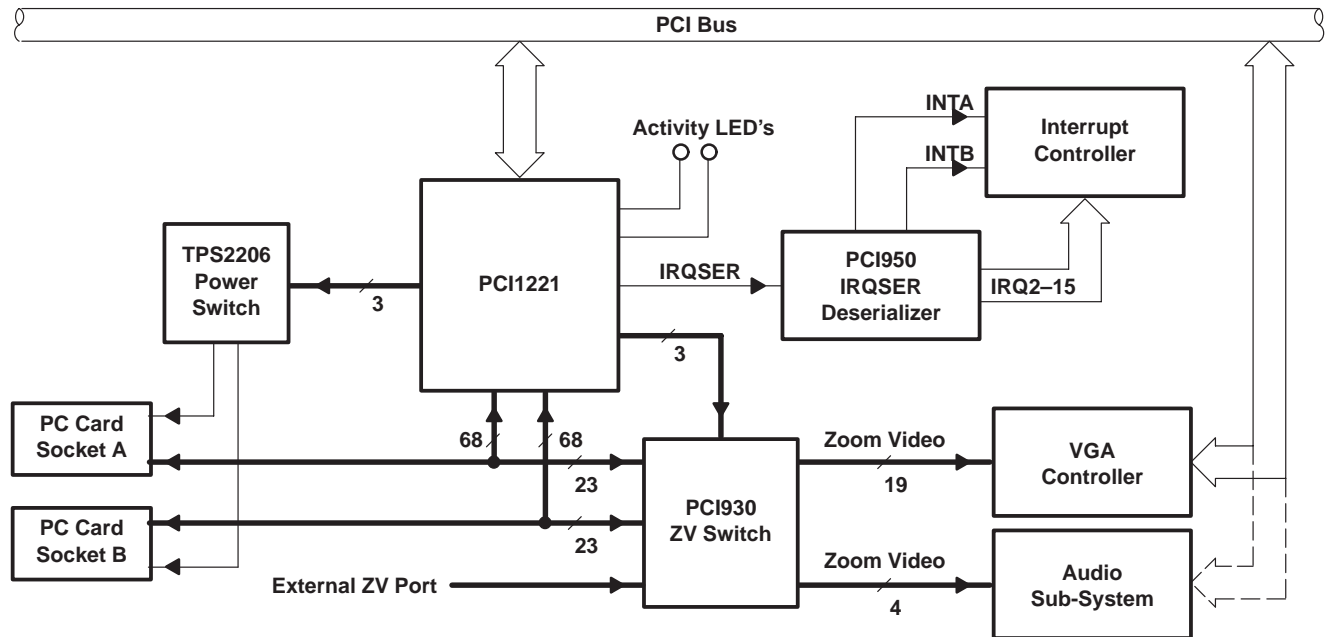

NOTE: The PC Card interface is 68 pins for CardBus and 16-bit PC Cards. In zoomed-video mode 23 pins are used for routing the zoomed video signals to the VGA controller.

# PCI1221 GHK/PDV PC CARD CONTROLLERS

SCPS042 – JULY 1998

## terminal assignments

### PDV LOW-PROFILE QUAD FLAT PACKAGE TOP VIEW

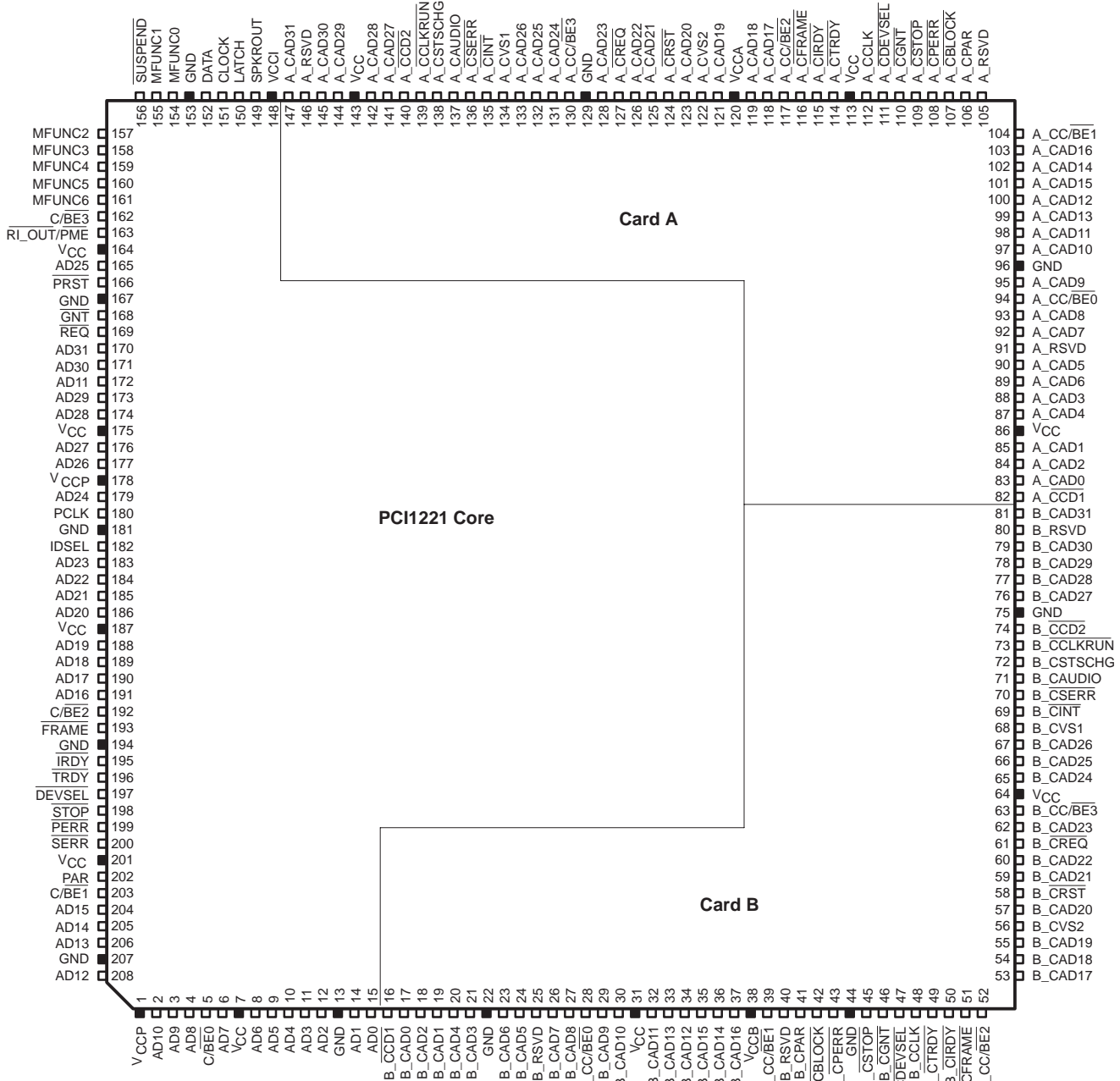

PCI-to-CardBus Pin Diagram

# PCI1221 GHK/PDV PC CARD CONTROLLERS

SCPS042 – JULY 1998

## terminal assignments (continued)

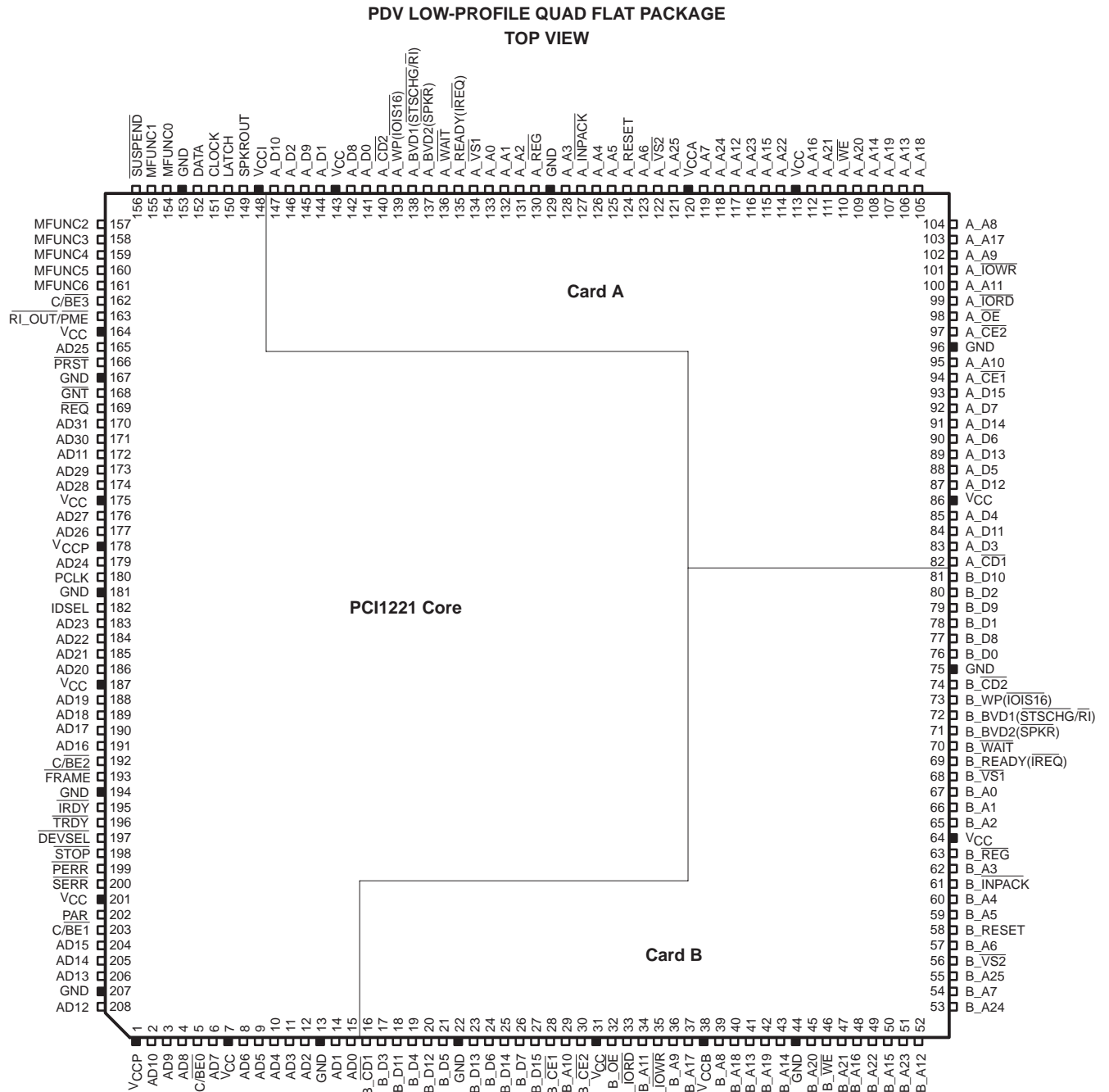

PCI-to-PC Card (16-Bit) Diagram

# PCI1221 GHK/PDV PC CARD CONTROLLERS

SCPS042 – JULY 1998

## terminal assignments (continued)

GHK PLASTIC BALL GRID ARRAY  
BOTTOM VIEW

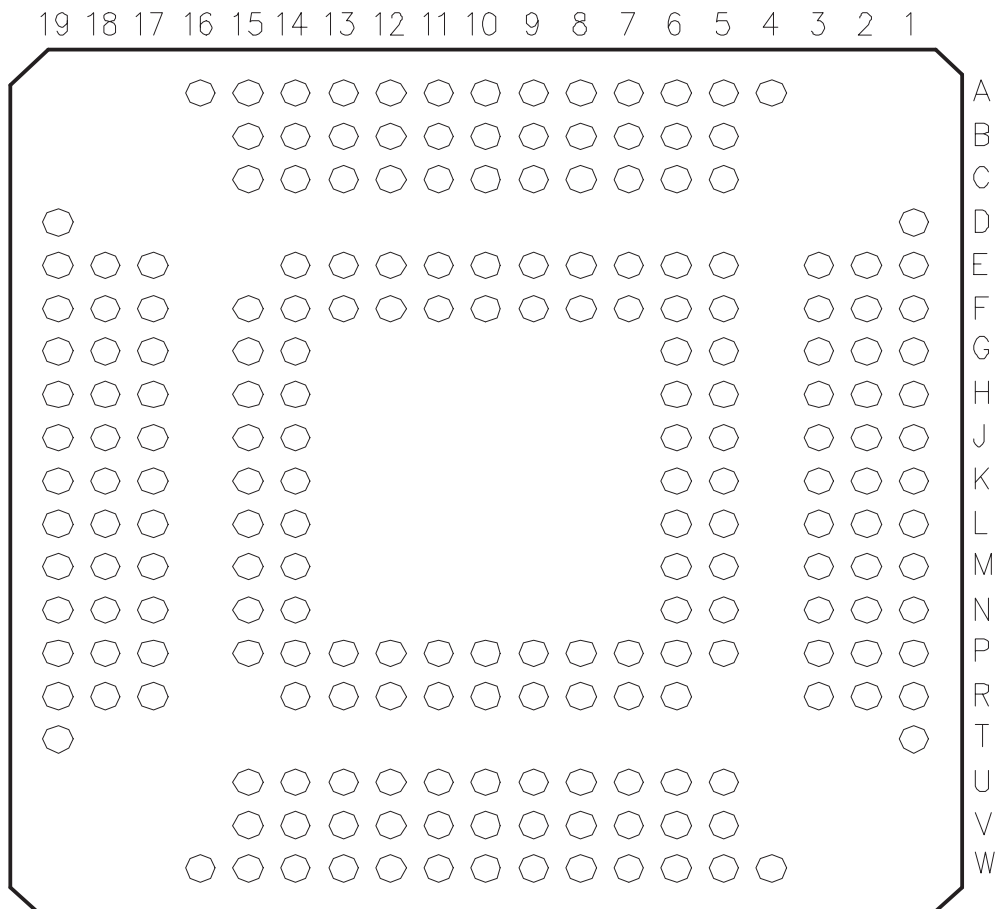

## signal names and terminal assignments

Table 1 and Table 2 show the terminal assignments for the CardBus PC Card; Table 3 and Table 4 show the terminal assignments for the 16-bit PC Card; Table 1 and Table 3 show the CardBus PC Card and the 16-bit PC Card terminals sorted alphanumerically by the associated GHK package terminal number; and Table 2 and Table 4 show the CardBus PC Card and the 16-bit PC Card terminals sorted alphanumerically by the signal name and it's associated terminal numbers.

# PCI1221 GHK/PDV PC CARD CONTROLLERS

SCPS042 – JULY 1998

**Table 1. CardBus PC Card Signal Names by GHK/PDV Pin Number**

PIN NO.			PIN NO.			PIN NO.			PIN NO.		
GHK	PDV	SIGNAL NAME	GHK	PDV	SIGNAL NAME	GHK	PDV	SIGNAL NAME	GHK	PDV	SIGNAL NAME
D1	1	V <sub>CCP</sub>	F3	7	V <sub>CC</sub>	K18	129	GND	R19	110	A <sub>CGNT</sub>
A4	208	AD12	F2	8	AD6	K14	132	A <sub>CAD25</sub>	P5	50	B <sub>CIRDY</sub>
E6	206	AD13	E7	201	V <sub>CC</sub>	K15	131	A <sub>CAD24</sub>	R2	49	B <sub>CTRDY</sub>
C6	202	PAR	C7	197	DEVSEL	K17	130	A <sub>CC/BE3</sub>	V5	57	B <sub>CAD20</sub>
F7	198	STOP	F8	193	FRAME	L2	30	B <sub>CAD10</sub>	V6	60	B <sub>CAD22</sub>
E8	194	GND	E9	189	AD18	L3	31	V <sub>CC</sub>	U7	64	V <sub>CC</sub>
A8	190	AD17	A9	185	AD21	L6	32	B <sub>CAD11</sub>	U8	68	B <sub>CVS1</sub>
B9	186	AD20	B10	181	GND	L1	29	B <sub>CAD9</sub>	V9	72	B <sub>CSTSCHG</sub>
C10	182	IDSEL	C11	177	AD26	L17	125	A <sub>CAD21</sub>	W10	76	B <sub>CAD27</sub>
E11	178	V <sub>CCP</sub>	B12	173	AD29	K19	128	A <sub>CAD23</sub>	P10	80	B <sub>RSVD</sub>
A12	174	AD28	B13	169	REQ	L14	127	A <sub>CREQ</sub>	P11	84	A <sub>CAD2</sub>
A13	170	AD31	E13	165	AD25	L15	126	A <sub>CAD22</sub>	U12	88	A <sub>CAD3</sub>
A14	166	PRST	G15	149	SPKROUT	M1	34	B <sub>CAD12</sub>	V13	92	A <sub>CAD7</sub>
A15	162	C/BE3	F14	152	DATA	M2	35	B <sub>CAD15</sub>	V14	96	GND
E14	159	MFUNC4	E19	151	CLOCK	M3	36	B <sub>CAD14</sub>	P14	100	A <sub>CAD12</sub>
C15	158	MFUNC3	F17	150	LATCH	L5	33	B <sub>CAD13</sub>	R18	109	A <sub>CSTOP</sub>
A16	157	MFUNC2	F1	10	AD4	M18	121	A <sub>CAD19</sub>	N14	108	A <sub>CPERR</sub>
E3	2	AD10	H6	11	AD3	L18	124	A <sub>CRST</sub>	P15	107	A <sub>CBLOCK</sub>
C5	207	GND	G3	12	AD2	L19	123	A <sub>CAD20</sub>	T1	52	B <sub>CC/BE2</sub>
B5	205	AD14	G5	9	AD5	M19	122	A <sub>CVS2</sub>	R3	51	B <sub>CFRAME</sub>
A5	203	C/BE1	G17	145	A <sub>CAD30</sub>	M5	38	V <sub>CCB</sub>	P7	56	B <sub>CVS2</sub>
A6	199	PERR	F18	148	V <sub>CCI</sub>	N1	39	B <sub>CC/BE1</sub>	U6	59	B <sub>CAD21</sub>
A7	195	IRDY	F19	147	A <sub>CAD31</sub>	N2	40	B <sub>RSVD</sub>	P8	63	B <sub>CC/BE3</sub>
B8	191	AD16	G14	146	A <sub>RSVD</sub>	M6	37	B <sub>CAD16</sub>	R8	67	B <sub>CAD26</sub>
C9	187	V <sub>CC</sub>	G1	14	AD1	N18	117	A <sub>CC/BE2</sub>	W9	71	B <sub>CAUDIO</sub>
E10	183	AD23	H5	15	AD0	M17	120	V <sub>CCA</sub>	P9	75	GND
F11	179	AD24	H3	16	B <sub>CCD1</sub>	M15	119	A <sub>CAD18</sub>	R10	79	B <sub>CAD30</sub>
A11	175	V <sub>CC</sub>	G2	13	GND	N19	118	A <sub>CAD17</sub>	U11	83	A <sub>CAD0</sub>
E12	171	AD30	H14	141	A <sub>CAD27</sub>	N6	42	B <sub>CBLOCK</sub>	V12	87	A <sub>CAD4</sub>
F12	167	GND	G18	144	A <sub>CAD29</sub>	P1	43	B <sub>CPERR</sub>	W13	91	A <sub>RSVD</sub>
C14	163	RI <sub>OUT</sub> /PME	G19	143	V <sub>CC</sub>	P2	44	GND	W14	95	A <sub>CAD9</sub>
F13	160	MFUNC5	H15	142	A <sub>CAD28</sub>	N3	41	B <sub>CPAR</sub>	W15	99	A <sub>CAD13</sub>
E17	155	MFUNC1	H1	18	B <sub>CAD2</sub>	N15	113	V <sub>CC</sub>	V15	101	A <sub>CAD15</sub>
D19	156	SUSPEND	J1	19	B <sub>CAD1</sub>	N17	116	A <sub>CFRAME</sub>	U15	103	A <sub>CAD16</sub>
F5	3	AD9	J2	20	B <sub>CAD4</sub>	M14	115	A <sub>CIRDY</sub>	R17	106	A <sub>CPAR</sub>
G6	4	AD8	H2	17	B <sub>CAD0</sub>	P19	114	A <sub>CTRDY</sub>	W4	53	B <sub>CAD17</sub>
E2	5	C/BE0	J15	137	A <sub>CAUDIO</sub>	P3	46	B <sub>CGNT</sub>	U5	54	B <sub>CAD18</sub>
F6	204	AD15	H17	140	A <sub>CCD2</sub>	R1	47	B <sub>CDEVSEL</sub>	R6	55	B <sub>CAD19</sub>
B6	200	SERR	H18	139	A <sub>CCLKRUN</sub>	P6	48	B <sub>CCLK</sub>	W5	58	B <sub>CRST</sub>
B7	196	TRDY	H19	138	A <sub>CSTSCHG</sub>	N5	45	B <sub>CSTOP</sub>	W6	62	B <sub>CAD23</sub>
C8	192	C/BE2	J5	22	GND	R7	61	B <sub>CREQ</sub>	W7	66	B <sub>CAD25</sub>
F9	188	AD19	J6	23	B <sub>CAD6</sub>	V7	65	B <sub>CAD24</sub>	W8	70	B <sub>CSERR</sub>
F10	184	AD22	K1	24	B <sub>CAD5</sub>	V8	69	B <sub>CINT</sub>	R9	74	B <sub>CCD2</sub>
A10	180	PCLK	J3	21	B <sub>CAD3</sub>	U9	73	B <sub>CCLKRUN</sub>	U10	78	B <sub>CAD29</sub>
B11	176	AD27	J19	133	A <sub>CAD26</sub>	V10	77	B <sub>CAD28</sub>	V11	82	A <sub>CCD1</sub>
C12	172	AD11	J14	136	A <sub>CSERR</sub>	W11	81	B <sub>CAD31</sub>	W12	86	V <sub>CC</sub>
C13	168	GNT	J17	135	A <sub>CINT</sub>	R11	85	A <sub>CAD1</sub>	R12	90	A <sub>CAD5</sub>
B14	164	V <sub>CC</sub>	J18	134	A <sub>CVS1</sub>	P12	89	A <sub>CAD6</sub>	P13	94	A <sub>CC/BE0</sub>
B15	161	MFUNC6/CLKRUN	K3	26	B <sub>CAD7</sub>	U13	93	A <sub>CAD8</sub>	U14	98	A <sub>CAD11</sub>
E18	153	GND	K5	27	B <sub>CAD8</sub>	R13	97	A <sub>CAD10</sub>	R14	102	A <sub>CAD14</sub>
F15	154	MFUNC0	K6	28	B <sub>CC/BE0</sub>	P18	112	A <sub>CCLK</sub>	W16	104	A <sub>CC/BE1</sub>
E1	6	AD7	K2	25	B <sub>RSVD</sub>	P17	111	A <sub>CDEVSEL</sub>	T19	105	A <sub>RSVD</sub>

# PCI1221 GHK/PDV PC CARD CONTROLLERS

SCPS042 – JULY 1998

**Table 2. CardBus PC Card Signal Names Sorted Alphabetically**

SIGNAL NAME	PIN NO.		SIGNAL NAME	PIN NO.		SIGNAL NAME	PIN NO.		SIGNAL NAME	PIN NO.	
	GHK	PDV		GHK	PDV		GHK	PDV		GHK	PDV
A_CAD0	U11	83	A_CSTOP	R18	109	B_CAD12	M1	34	CLOCK	E19	151
A_CAD1	R11	85	A_CSTSCHG	H19	138	B_CAD13	L5	33	DATA	F14	152
A_CAD2	P11	84	A_CTRDY	P19	114	B_CAD14	M3	36	DEVSEL	C7	197
A_CAD3	U12	88	A_CVS1	J18	134	B_CAD15	M2	35	FRAME	F8	193
A_CAD4	V12	87	A_CVS2	M19	122	B_CAD16	M6	37	GND	E8	194
A_CAD5	R12	90	A_RSVD	G14	146	B_CAD17	W4	53	GND	C5	207
A_CAD6	P12	89	A_RSVD	W13	91	B_CAD18	U5	54	GND	F12	167
A_CAD7	V13	92	A_RSVD	T19	105	B_CAD19	R6	55	GND	E18	153
A_CAD8	U13	93	AD0	H5	15	B_CAD20	V5	57	GND	B10	181
A_CAD9	W14	95	AD1	G1	14	B_CAD21	U6	59	GND	G2	13
A_CAD10	R13	97	AD2	G3	12	B_CAD22	V6	60	GND	J5	22
A_CAD11	U14	98	AD3	H6	11	B_CAD23	W6	62	GND	K18	129
A_CAD12	P14	100	AD4	F1	10	B_CAD24	V7	65	GND	P2	44
A_CAD13	W15	99	AD5	G5	9	B_CAD25	W7	66	GND	V14	96
A_CAD14	R14	102	AD6	F2	8	B_CAD26	R8	67	GND	P9	75
A_CAD15	V15	101	AD7	E1	6	B_CAD27	W10	76	GNT	C13	168
A_CAD16	U15	103	AD8	G6	4	B_CAD28	V10	77	IDSEL	C10	182
A_CAD17	N19	118	AD9	F5	3	B_CAD29	U10	78	IRDY	A7	195
A_CAD18	M15	119	AD10	E3	2	B_CAD30	R10	79	LATCH	F17	150
A_CAD19	M18	121	AD11	C12	172	B_CAD31	W11	81	MFUNC0	F15	154
A_CAD20	L19	123	AD12	A4	208	B_CAUDIO	W9	71	MFUNC1	E17	155
A_CAD21	L17	125	AD13	E6	206	B_CBLOCK	N6	42	MFUNC2	A16	157
A_CAD22	L15	126	AD14	B5	205	B_CC/BE0	K6	28	MFUNC3	C15	158
A_CAD23	K19	128	AD15	F6	204	B_CC/BE1	N1	39	MFUNC4	E14	159
A_CAD24	K15	131	AD16	B8	191	B_CC/BE2	T1	52	MFUNC5	F13	160
A_CAD25	K14	132	AD17	A8	190	B_CC/BE3	P8	63	MFUNC6/CLKRUN	B15	161
A_CAD26	J19	133	AD18	E9	189	B_CCD1	H3	16	PAR	C6	202
A_CAD27	H14	141	AD19	F9	188	B_CCD2	R9	74	PCLK	A10	180
A_CAD28	H15	142	AD20	B9	186	B_CCLK	P6	48	PERR	A6	199
A_CAD29	G18	144	AD21	A9	185	B_CCLKRUN	U9	73	PRST	A14	166
A_CAD30	G17	145	AD22	F10	184	B_CDEVSEL	R1	47	REQ	B13	169
A_CAD31	F19	147	AD23	E10	183	B_CFRAME	R3	51	RI_OUT/PME	C14	163
A_CAUDIO	J15	137	AD24	F11	179	B_CGNT	P3	46	SERR	B6	200
A_CBLOCK	P15	107	AD25	E13	165	B_CINT	V8	69	SPKROUT	G15	149
A_CC/BE0	P13	94	AD26	C11	177	B_CIRDY	P5	50	STOP	F7	198
A_CC/BE1	W16	104	AD27	B11	176	B_CPAR	N3	41	SUSPEND	D19	156
A_CC/BE2	N18	117	AD28	A12	174	B_CPERR	P1	43	TRDY	B7	196
A_CC/BE3	K17	130	AD29	B12	173	B_CREQ	R7	61	VCC	C9	187
A_CCD1	V11	82	AD30	E12	171	B_CRST	W5	58	VCC	A11	175
A_CCD2	H17	140	AD31	A13	170	B_CSERR	W8	70	VCC	B14	164
A_CCLK	P18	112	B_CAD0	H2	17	B_CSTOP	N5	45	VCC	F3	7
A_CCLKRUN	H18	139	B_CAD1	J1	19	B_CSTSCHG	V9	72	VCC	E7	201
A_CDEVSEL	P17	111	B_CAD2	H1	18	B_CTRDY	R2	49	VCC	G19	143
A_CFRAME	N17	116	B_CAD3	J3	21	B_CVS1	U8	68	VCC	L3	31
A_CGNT	R19	110	B_CAD4	J2	20	B_CVS2	P7	56	VCC	N15	113
A_CINT	J17	135	B_CAD5	K1	24	B_RSVD	K2	25	VCC	U7	64
A_CIRDY	M14	115	B_CAD6	J6	23	B_RSVD	N2	40	VCC	W12	86
A_CPAR	R17	106	B_CAD7	K3	26	B_RSVD	P10	80	VCCA	M17	120
A_CPERR	N14	108	B_CAD8	K5	27	C/BE0	E2	5	VCCB	M5	38
A_CREQ	L14	127	B_CAD9	L1	29	C/BE1	A5	203	VCCI	F18	148
A_CRST	L18	124	B_CAD10	L2	30	C/BE2	C8	192	VCCP	D1	1
A_CSERR	J14	136	B_CAD11	L6	32	C/BE3	A15	162	VCCP	E11	178



# PCI1221 GHK/PDV PC CARD CONTROLLERS

SCPS042 – JULY 1998

**Table 3. 16-Bit PC Card Signal Names by GHK/PDV Pin Number**

PIN NO.			PIN NO.			PIN NO.		
GHK	PDV	SIGNAL NAME	GHK	PDV	SIGNAL NAME	GHK	PDV	SIGNAL NAME
D1	1	V <sub>CCP</sub>	F3	7	V <sub>CC</sub>	K18	129	GND
A4	208	AD12	F2	8	AD6	K14	132	A_A1
E6	206	AD13	E7	201	V <sub>CC</sub>	K15	131	A_A2
C6	202	PAR	C7	197	DEVSEL	K17	130	A_REG
F7	198	STOP	F8	193	FRAME	L2	30	B_CE2
E8	194	GND	E9	189	AD18	L3	31	V <sub>CC</sub>
A8	190	AD17	A9	185	AD21	L6	32	B_OE
B9	186	AD20	B10	181	GND	L1	29	B_A10
C10	182	IDSEL	C11	177	AD26	L17	125	A_A5
E11	178	V <sub>CCP</sub>	B12	173	AD29	K19	128	A_A3
A12	174	AD28	B13	169	REQ	L14	127	A_INPACK
A13	170	AD31	E13	165	AD25	L15	126	A_A4
A14	166	PRST	G15	149	SPKROUT	M1	34	B_A11
A15	162	C/BE3	F14	152	DATA	M2	35	B_IOWR
E14	159	MFUNC4	E19	151	CLOCK	M3	36	B_A9
C15	158	MFUNC3	F17	150	LATCH	L5	33	B_IORD
A16	157	MFUNC2	F1	10	AD4	M18	121	A_A25
E3	2	AD10	H6	11	AD3	L18	124	A_RESET
C5	207	GND	G3	12	AD2	L19	123	A_A6
B5	205	AD14	G5	9	AD5	M19	122	A_VS2
A5	203	C/BE1	G17	145	A_D9	M5	38	V <sub>CCB</sub>
A6	199	PERR	F18	148	V <sub>CCI</sub>	N1	39	B_A8
A7	195	IRDY	F19	147	A_D10	N2	40	B_A18
B8	191	AD16	G14	146	A_D2	M6	37	B_A17
C9	187	V <sub>CC</sub>	G1	14	AD1	N18	117	A_A12
E10	183	AD23	H5	15	AD0	M17	120	V <sub>CCA</sub>
F11	179	AD24	H3	16	B_CD1	M15	119	A_A7
A11	175	V <sub>CC</sub>	G2	13	GND	N19	118	A_A24
E12	171	AD30	H14	141	A_D0	N6	42	B_A19
F12	167	GND	G18	144	A_D1	P1	43	B_A14
C14	163	RI_OUT/PME	G19	143	V <sub>CC</sub>	P2	44	GND
F13	160	MFUNC5	H15	142	A_D8	N3	41	B_A13
E17	155	MFUNC1	H1	18	B_D11	N15	113	V <sub>CC</sub>
D19	156	SUSPEND	J1	19	B_D4	N17	116	A_A23
F5	3	AD9	J2	20	B_D12	M14	115	A_A15
G6	4	AD8	H2	17	B_D3	P19	114	A_A22
E2	5	C/BE0	J15	137	A_BVD2(SPKR)	P3	46	B_WE
F6	204	AD15	H17	140	A_CD2	R1	47	B_A21
B6	200	SERR	H18	139	A_WP(IOIS16)	P6	48	B_A16
B7	196	TRDY	H19	138	A_BVD1(STSCHG/RI)	N5	45	B_A20
C8	192	C/BE2	J5	22	GND	R7	61	B_INPACK
F9	188	AD19	J6	23	B_D13	V7	65	B_A2
F10	184	AD22	K1	24	B_D6	V8	69	B_READY(IREQ)
A10	180	PCLK	J3	21	B_D5	U9	73	B_WP(IOIS16)
B11	176	AD27	J19	133	A_A0	V10	77	B_D8
C12	172	AD11	J14	136	A_WAIT	W11	81	B_D10
C13	168	GNT	J17	135	A_READY(IREQ)	R11	85	A_D4
B14	164	V <sub>CC</sub>	J18	134	A_VST	P12	89	A_D13
B15	161	MFUNC6	K3	26	B_D7	U13	93	A_D15
E18	153	GND	K5	27	B_D15	R13	97	A_CE2
F15	154	MFUNC0	K6	28	B_CE1	P18	112	A_A16
E1	6	AD7	K2	25	B_D14	P17	111	A_A21

# PCI1221 GHK/PDV PC CARD CONTROLLERS

SCPS042 – JULY 1998

**Table 3. 16-Bit PC Card Signal Names by GHK/PDV Pin Number (Continued)**

PIN NO.			PIN NO.			PIN NO.		
GHK	PDV	SIGNAL NAME	GHK	PDV	SIGNAL NAME	GHK	PDV	SIGNAL NAME
R19	110	A_WE	T1	52	B_A12	U5	54	B_A7
P5	50	B_A15	R3	51	B_A23	R6	55	B_A25
R2	49	B_A22	P7	56	B_VS2	W5	58	B_RESET
V5	57	B_A6	U6	59	B_A5	W6	62	B_A3
V6	60	B_A4	P8	63	B_REG	W7	66	B_A1
U7	64	VCC	R8	67	B_A0	W8	70	B_WAIT
U8	68	B_VS1	W9	71	B_BVD2(SPKR)	R9	74	B_CD2
V9	72	B_BVD1(STSCHG/RI)	P9	75	GND	U10	78	B_D1
W10	76	B_D0	R10	79	B_D9	V11	82	A_CD1
P10	80	B_D2	U11	83	A_D3	W12	86	VCC
P11	84	A_D11	V12	87	A_D12	R12	90	A_D6
U12	88	A_D5	W13	91	A_D14	P13	94	A_CE1
V13	92	A_D7	W14	95	A_A10	U14	98	A_OE
V14	96	GND	W15	99	A_IORD	R14	102	A_A9
P14	100	A_A11	V15	101	A_IOWR	W16	104	A_A8
R18	109	A_A20	U15	103	A_A17	T19	105	A_A18
N14	108	A_A14	R17	106	A_A13			
P15	107	A_A19	W4	53	B_A24			

**Table 4. 16-Bit PC Card Signal Names Sorted Alphabetically**

SIGNAL NAME	PIN NO.		SIGNAL NAME	PIN NO.		SIGNAL NAME	PIN NO.	
	GHK	PDV		GHK	PDV		GHK	PDV
A_A0	J19	133	A_A20	R18	109	A_D8	H15	142
A_A1	K14	132	A_A21	P17	111	A_D9	G17	145
A_A2	K15	131	A_A22	P19	114	A_D10	F19	147
A_A3	K19	128	A_A23	N17	116	A_D11	P11	84
A_A4	L15	126	A_A24	N19	118	A_D12	V12	87
A_A5	L17	125	A_A25	M18	121	A_D13	P12	89
A_A6	L19	123	A_BVD1(STSCHG/RI)	H19	138	A_D14	W13	91
A_A7	M15	119	A_BVD2(SPKR)	J15	137	A_D15	U13	93
A_A8	W16	104	A_CD1	V11	82	A_INPACK	L14	127
A_A9	R14	102	A_CD2	H17	140	A_IORD	W15	99
A_A10	W14	95	A_CE1	P13	94	A_IOWR	V15	101
A_A11	P14	100	A_CE2	R13	97	A_OE	U14	98
A_A12	N18	117	A_D0	H14	141	A_READY(IREQ)	J17	135
A_A13	R17	106	A_D1	G18	144	A_REG	K17	130
A_A14	N14	108	A_D2	G14	146	A_RESET	L18	124
A_A15	M14	115	A_D3	U11	83	A_VS1	J18	134
A_A16	P18	112	A_D4	R11	85	A_VS2	M19	122
A_A17	U15	103	A_D5	U12	88	A_WAIT	J14	136
A_A18	T19	105	A_D6	R12	90	A_WE	R19	110
A_A19	P15	107	A_D7	V13	92	A_WP(10IS16)	H18	139

# PCI1221 GHK/PDV PC CARD CONTROLLERS

SCPS042 – JULY 1998

**Table 4. 16-Bit PC Card Signal Names Sorted Alphabetically (Continued)**

SIGNAL NAME	PIN NO.		SIGNAL NAME	PIN NO.		SIGNAL NAME	PIN NO.	
	GHK	PDV		GHK	PDV		GHK	PDV
AD0	H5	15	B_A18	N2	40	GND	E8	194
AD1	G1	14	B_A19	N6	42	GND	C5	207
AD2	G3	12	B_A20	N5	45	GND	F12	167
AD3	H6	11	B_A21	R1	47	GND	E18	153
AD4	F1	10	B_A22	R2	49	GND	B10	181
AD5	G5	9	B_A23	R3	51	GND	G2	13
AD6	F2	8	B_A24	W4	53	GND	J5	22
AD7	E1	6	B_A25	R6	55	GND	K18	129
AD8	G6	4	B_BVD1(STSCHG/RI)	V9	72	GND	P2	44
AD9	F5	3	B_BVD2(SPKR)	W9	71	GND	V14	96
AD10	E3	2	B_CD1	H3	16	GND	P9	75
AD11	C12	172	B_CD2	R9	74	GNT	C13	168
AD12	A4	208	B_CE1	K6	28	IDSEL	C10	182
AD13	E6	206	B_CE2	L2	30	TRDY	A7	195
AD14	B5	205	B_D0	W10	76	LATCH	F17	150
AD15	F6	204	B_D1	U10	78	MFUNC0	F15	154
AD16	B8	191	B_D2	P10	80	MFUNC1	E17	155
AD17	A8	190	B_D3	H2	17	MFUNC2	A16	157
AD18	E9	189	B_D4	J1	19	MFUNC3	C15	158
AD19	F9	188	B_D5	J3	21	MFUNC4	E14	159
AD20	B9	186	B_D6	K1	24	MFUNC5	F13	160
AD21	A9	185	B_D7	K3	26	MFUNC6	B15	161
AD22	F10	184	B_D8	V10	77	PAR	C6	202
AD23	E10	183	B_D9	R10	79	PCLK	A10	180
AD24	F11	179	B_D10	W11	81	PERR	A6	199
AD25	E13	165	B_D11	H1	18	PRST	A14	166
AD26	C11	177	B_D12	J2	20	REQ	B13	169
AD27	B11	176	B_D13	J6	23	RI_OUT/PME	C14	163
AD28	A12	174	B_D14	K2	25	SERR	B6	200
AD29	B12	173	B_D15	K5	27	SPKROUT	G15	149
AD30	E12	171	B_INPACK	R7	61	STOP	F7	198
AD31	A13	170	B_IORD	L5	33	SUSPEND	D19	156
B_A0	R8	67	B_IOWR	M2	35	TRDY	B7	196
B_A1	W7	66	B_OE	L6	32	VCC	A11	175
B_A2	V7	65	B_READY(IREQ)	V8	69	VCC	C9	187
B_A3	W6	62	B_REG	P8	63	VCC	B14	164
B_A4	V6	60	B_RESET	W5	58	VCC	F3	7
B_A5	U6	59	B_VS1	U8	68	VCC	E7	201
B_A6	V5	57	B_VS2	P7	56	VCC	G19	143
B_A7	U5	54	B_WAIT	W8	70	VCC	L3	31
B_A8	N1	39	B_WE	P3	46	VCC	N15	113
B_A9	M3	36	B_WP(IOIS16)	U9	73	VCC	U7	64
B_A10	L1	29	C/BE0	E2	5	VCC	W12	86
B_A11	M1	34	C/BE1	A5	203	VCCA	M17	120
B_A12	T1	52	C/BE2	C8	192	VCCB	M5	38
B_A13	N3	41	C/BE3	A15	162	VCCI	F18	148
B_A14	P1	43	CLOCK	E19	151	VCCP	D1	1
B_A15	P5	50	DATA	F14	152	VCCP	E11	178
B_A16	P6	48	DEVSEL	C7	197			
B_A17	M6	37	FRAME	F8	193			

# PCI1221 GHK/PDV PC CARD CONTROLLERS

SCPS042 – JULY 1998

## Terminal Functions

The terminals are grouped in tables by functionality, such as PCI system function, power-supply function, etc. The terminal numbers are also listed for convenient reference.

### power supply

TERMINAL			FUNCTION
NAME	PDV NUMBER	GHK NUMBER	
GND	13, 22, 44, 75, 96, 129, 153, 167, 181, 194, 207	G2, J5, P2, P9, V14, K18, E18, F12, B10, E8, C5	Device ground terminals
VCC	7, 31, 64, 86, 113, 143, 164, 175, 187, 201	F3, L3, U7, W12, N15, G19, B14, A11, C9, E7	Power supply terminal for core logic (3.3 V)
VCCA	120	M17	Clamp voltage for PC Card A interface. Indicates Card A signaling environment, 5 V or 3.3 V.
VCCB	38	M5	Clamp voltage for PC Card B interface. Indicates Card B signaling environment, 5 V or 3.3 V.
VCCI	148	F18	Clamp voltage for interrupt subsystem interface and miscellaneous I/O. (5 V or 3.3 V)
VCCP	1, 178	D1, E11	Clamp voltage for PCI signaling (5 V or 3.3 V)

### PC Card power switch

TERMINAL			I/O TYPE	FUNCTION
NAME	PDV	GHK		
CLOCK	151	E19	I/O	Three-line power switch clock. Information on the DATA line is sampled at the rising edge of CLOCK. CLOCK defaults to an input, but can be changed to a PCI1221 output by using the P2CCLK bit in the System Control Register. The TPS2206 defines the maximum frequency of this signal to be 2 MHz.  If a system design defines this terminal as an output, then this terminal requires an external pull down resistor. The frequency of the PCI1221 output CLOCK is derived from dividing the PCI CLK by 36.
DATA	152	F14	O	Three-line power switch data. DATA is used to serially communicate socket power control information to the power switch.
LATCH	150	F17	O	Three-line power switch latch. LATCH is asserted by the PCI1221 to indicate to the PC Card power switch that the data on the DATA line is valid. When a pulldown resistor is implemented on this terminal, the MFUNC4 and MFUNC1 terminals provide the serial EEPROM SCL and SDA interface.

### PCI system

TERMINAL			I/O TYPE	FUNCTION
NAME	PDV	GHK		
PCLK	180	A10	I	PCI bus clock. PCLK provides timing for all transactions on the PCI bus. All PCI signals are sampled at the rising edge of PCLK.
$\overline{\text{PRST}}$	166	A14	I	PCI reset. When the PCI bus reset is asserted, $\overline{\text{PRST}}$ causes the PCI1221 to place all output buffers in a high-impedance state and reset all internal registers. When $\overline{\text{PRST}}$ is asserted, the device is completely nonfunctional. After $\overline{\text{PRST}}$ is deasserted, the PCI1221 is in its default state.  When the $\overline{\text{SUSPEND}}$ and $\overline{\text{PRST}}$ are asserted, the device is protected from the $\overline{\text{PRST}}$ clearing the internal registers. All outputs are placed in a high-impedance state, but the contents of the registers are preserved.

Terminal Functions (Continued)

PCI address and data

TERMINAL NAME	PIN NUMBER		I/O TYPE	FUNCTION
	PDV	GHK		
AD31	170	A13	I/O	PCI address/data bus. These signals make up the multiplexed PCI address and data bus on the primary interface. During the address phase of a primary bus PCI cycle, AD31-AD0 contain a 32-bit address or other destination information. During the data phase, AD31-AD0 contain data.
AD30	171	E12		
AD29	173	B12		
AD28	174	A12		
AD27	176	B11		
AD26	177	C11		
AD25	165	E13		
AD24	179	F11		
AD23	183	E10		
AD22	184	F10		
AD21	185	A9		
AD20	186	B9		
AD19	188	F9		
AD18	189	E9		
AD17	190	A8		
AD16	191	B8		
AD15	204	F6		
AD14	205	B5		
AD13	206	E6		
AD12	208	A4		
AD11	172	C12		
AD10	2	E3		
AD9	3	F5		
AD8	4	G6		
AD7	6	E1		
AD6	8	F2		
AD5	9	G5		
AD4	10	F1		
AD3	11	H6		
AD2	12	G3		
AD1	14	G1		
AD0	15	H5		
$\overline{C/BE3}$	162	A15	I/O	PCI bus commands and byte enables. These signals are multiplexed on the same PCI terminals. During the address phase of a primary bus PCI cycle, $\overline{C/BE3}$ - $\overline{C/BE0}$ define the bus command. During the data phase, this 4-bit bus is used as byte enables. The byte enables determine which byte paths of the full 32-bit data bus carry meaningful data. $\overline{C/BE0}$ applies to byte 0 (AD7-AD0), $\overline{C/BE1}$ applies to byte 1 (AD15-AD8), $\overline{C/BE2}$ applies to byte 2 (AD23-AD16), and $\overline{C/BE3}$ applies to byte 3 (AD31-AD24).
$\overline{C/BE2}$	192	C8		
$\overline{C/BE1}$	203	A5		
$\overline{C/BE0}$	5	E2		
PAR	202	C6	I/O	PCI bus parity. In all PCI bus read and write cycles, the PCI1221 calculates even parity across the AD31-AD0 and $\overline{C/BE3}$ - $\overline{C/BE0}$ buses. As an initiator during PCI cycles, the PCI1221 outputs this parity indicator with a one-PCLK delay. As a target during PCI cycles, the calculated parity is compared to the initiator's parity indicator. A compare error results in the assertion of a parity error (PERR).

# PCI1221 GHK/PDV PC CARD CONTROLLERS

SCPS042 – JULY 1998

## Terminal Functions (Continued)

### PCI interface control

TERMINAL NAME	PIN NUMBER		I/O TYPE	FUNCTION
	PDV	GHK		
$\overline{\text{DEVSEL}}$	197	C7	I/O	PCI device select. The PCI1221 asserts $\overline{\text{DEVSEL}}$ to claim a PCI cycle as the target device. As a PCI initiator on the bus, the PCI1221 monitors $\overline{\text{DEVSEL}}$ until a target responds. If no target responds before timeout occurs, the PCI1221 terminates the cycle with an initiator abort.
$\overline{\text{FRAME}}$	193	F8	I/O	PCI cycle frame. $\overline{\text{FRAME}}$ is driven by the initiator of a bus cycle. $\overline{\text{FRAME}}$ is asserted to indicate that a bus transaction is beginning, and data transfers continue while this signal is asserted. When $\overline{\text{FRAME}}$ is deasserted, the PCI bus transaction is in the final data phase.
$\overline{\text{GNT}}$	168	C13	I	PCI bus grant. $\overline{\text{GNT}}$ is driven by the PCI bus arbiter to grant the PCI1221 access to the PCI bus after the current data transaction has completed. $\overline{\text{GNT}}$ may or may not follow a PCI bus request, depending on the PCI bus parking algorithm.
IDSEL	182	C10	I	Initialization device select. IDSEL selects the PCI1221 during configuration space accesses. IDSEL can be connected to one of the upper 24 PCI address lines on the PCI bus.
$\overline{\text{IRDY}}$	195	A7	I/O	PCI initiator ready. $\overline{\text{IRDY}}$ indicates the PCI bus initiator's ability to complete the current data phase of the transaction. A data phase is completed on a rising edge of PCLK where both $\overline{\text{IRDY}}$ and $\overline{\text{TRDY}}$ are asserted. Until $\overline{\text{IRDY}}$ and $\overline{\text{TRDY}}$ are both sampled asserted, wait states are inserted.
$\overline{\text{PERR}}$	199	A6	I/O	PCI parity error indicator. $\overline{\text{PERR}}$ is driven by a PCI device to indicate that calculated parity does not match PAR when PERR is enabled through bit 6 of the command register.
$\overline{\text{REQ}}$	169	B13	O	PCI bus request. $\overline{\text{REQ}}$ is asserted by the PCI1221 to request access to the PCI bus as an initiator.
$\overline{\text{SERR}}$	200	B6	O	PCI system error. $\overline{\text{SERR}}$ is an output that is pulsed from the PCI1221 when enabled through the command register indicating a system error has occurred. The PCI1221 need not be the target of the PCI cycle to assert this signal. When $\overline{\text{SERR}}$ is enabled in the control register, this signal also pulses, indicating that an address parity error has occurred on a CardBus interface.
$\overline{\text{STOP}}$	198	F7	I/O	PCI cycle stop signal. $\overline{\text{STOP}}$ is driven by a PCI target to request the initiator to stop the current PCI bus transaction. $\overline{\text{STOP}}$ is used for target disconnects and is commonly asserted by target devices that do not support burst data transfers.
$\overline{\text{TRDY}}$	196	B7	I/O	PCI target ready. $\overline{\text{TRDY}}$ indicates the primary bus target's ability to complete the current data phase of the transaction. A data phase is completed on a rising edge of PCLK when both $\overline{\text{IRDY}}$ and $\overline{\text{TRDY}}$ are asserted. Until both $\overline{\text{IRDY}}$ and $\overline{\text{TRDY}}$ are asserted, wait states are inserted.

Terminal Functions (Continued)

multifunction and miscellaneous pins

TERMINAL NAME	PIN NUMBER		I/O TYPE	FUNCTION
	PDV	GHK		
MFUNC0	154	F15	I/O	Multifunction terminal 0. MFUNC0 can be configured as parallel PCI interrupt $\overline{\text{INTA}}$ , GPI0, GPO0, socket activity LED output, ZV switching outputs, CardBus audio PWM, $\overline{\text{GPE}}$ , or a parallel IRQ. Refer to the <i>multifunction routing register</i> description on page 62 for configuration details.
MFUNC1	155	E17	I/O	Multifunction terminal 1. MFUNC1 can be configured as parallel PCI interrupt $\overline{\text{INTB}}$ , GPI1, GPO1, socket activity LED output, ZV switching outputs, CardBus audio PWM, $\overline{\text{GPE}}$ , or a parallel IRQ. Refer to the <i>multifunction routing register</i> description on page 62 for configuration details.  Serial data (SDA). When the serial bus mode is implemented by pulling the LATCH terminal low, the MFUNC1 terminal provides the SDA signaling. The two pin serial interface is used to load the subsystem identification and other register defaults from an EEPROM after a PCI reset. Refer to the <i>serial bus interface implementation</i> description on page 29 for details on other serial bus applications.
MFUNC2	157	A16	I/O	Multifunction terminal 2. MFUNC2 can be configured as GPI2, GPO2, socket activity LED output, ZV switching outputs, CardBus audio PWM, $\overline{\text{GPE}}$ , or a parallel IRQ. Refer to the <i>multifunction routing register</i> description on page 62 for configuration details.
MFUNC3	158	C15	I/O	Multifunction terminal 3. MFUNC3 can be configured as a parallel IRQ or the serialized interrupt signal IRQSER. Refer to the <i>multifunction routing register</i> description on page 62 for configuration details.
MFUNC4	159	E14	I/O	Multifunction terminal 4. MFUNC4 can be configured as PCI $\overline{\text{LOCK}}$ , GPI3, GPO3, socket activity LED output, ZV switching outputs, CardBus audio PWM, $\overline{\text{GPE}}$ , or a parallel IRQ. Refer to the <i>multifunction routing register</i> description on page 62 for configuration details.  Serial clock (SCL). When the serial bus mode is implemented by pulling the LATCH terminal low, the MFUNC4 terminal provides the SCL signaling. The two pin serial interface is used to load the subsystem identification and other register defaults from an EEPROM after a PCI reset. Refer to the <i>serial bus interface implementation</i> description on page 29 for details on other serial bus applications.
MFUNC5	160	F13	I/O	Multifunction terminal 5. MFUNC5 can be configured as GPI4, GPO4, socket activity LED output, ZV switching outputs, CardBus audio PWM, $\overline{\text{GPE}}$ , or a parallel IRQ. Refer to the <i>multifunction routing register</i> description on page 62 for configuration details.
MFUNC6	161	B15	I/O	Multifunction terminal 6. MFUNC6 can be configured as a PCI $\overline{\text{CLKRUN}}$ or a parallel IRQ. Refer to the <i>multifunction routing register</i> description on page 62 for configuration details.
$\overline{\text{RI\_OUT/PME}}$	163	C14	O	Ring Indicate Out and Power Management Event Output. Terminal provides an output for ring-indicate or PME signals.
SPKROUT	149	G15	O	Speaker output. SPKROUT is the output to the host system that can carry $\overline{\text{SPKR}}$ or CAUDIO through the PCI1221 from the PC Card interface. SPKROUT is driven as the exclusive-OR combination of card $\overline{\text{SPKR}}$ /CAUDIO inputs.
$\overline{\text{SUSPEND}}$	156	D19	I	Suspend. $\overline{\text{SUSPEND}}$ is used to protect the internal registers from clearing when the $\overline{\text{PRST}}$ signal is asserted. See <i>suspend mode</i> description on page 40 for details.

# PCI1221 GHK/PDV PC CARD CONTROLLERS

SCPS042 – JULY 1998

## Terminal Functions (Continued)

### 16-bit PC Card address and data (slots A and B)

NAME	TERMINAL PIN NUMBER				I/O TYPE	FUNCTION
	SLOT A†		SLOT B‡			
	PDV	GHK	PDV	GHK		
A25	121	M18	55	R6	O	PC Card address. 16-bit PC Card address lines. A25 is the most-significant bit.
A24	118	N19	53	W4		
A23	116	N17	51	R3		
A22	114	P19	49	R2		
A21	111	P17	47	R1		
A20	109	R18	45	N5		
A19	107	P15	42	N6		
A18	105	T19	40	N2		
A17	103	U15	37	M6		
A16	112	P18	48	P6		
A15	115	M14	50	P5		
A14	108	N14	43	P1		
A13	106	R17	41	N3		
A12	117	N18	52	T1		
A11	100	P14	34	M1		
A10	95	W14	29	L1		
A9	102	R14	36	M3		
A8	104	W16	39	N1		
A7	119	M15	54	U5		
A6	123	L19	57	V5		
A5	125	L17	59	U6		
A4	126	L15	60	V6		
A3	128	K19	62	W6		
A2	131	K15	65	V7		
A1	132	K14	66	W7		
A0	133	J19	67	R8		
D15	93	U13	27	K5	I/O	PC Card data. 16-bit PC Card data lines. D15 is the most-significant bit.
D14	91	W13	25	K2		
D13	89	P12	23	J6		
D12	87	V12	20	J2		
D11	84	P11	18	H1		
D10	147	F19	81	W11		
D9	145	G17	79	R10		
D8	142	H15	77	V10		
D7	92	V13	26	K3		
D6	90	R12	24	K1		
D5	88	U12	21	J3		
D4	85	R11	19	J1		
D3	83	U11	17	H2		
D2	146	G14	80	P10		
D1	144	G18	78	U10		
D0	141	H14	76	W10		

† Terminal name for slot A is preceded with A\_. For example, the full name for terminals 121 and M18 are A\_A25.

‡ Terminal name for slot B is preceded with B\_. For example, the full name for terminals 55 and R6 are B\_A25.



Terminal Functions (Continued)

16-bit PC Card interface control (slots A and B)

NAME	TERMINAL PIN NUMBER				I/O TYPE	FUNCTION
	SLOT A†		SLOT B‡			
	PDV	GHK	PDV	GHK		
$\overline{\text{BVD1}}$ ( $\overline{\text{STSCHG}}/\overline{\text{RI}}$ )	138	H19	72	V9	I	Battery voltage detect 1. BVD1 is generated by 16-bit memory PC Cards that include batteries. BVD1 is used with BVD2 as an indication of the condition of the batteries on a memory PC Card. Both BVD1 and BVD2 are kept high when the battery is good. When BVD2 is low and BVD1 is high, the battery is weak and should be replaced. When BVD1 is low, the battery is no longer serviceable and the data in the memory PC Card is lost. See <i>ExCA card status-change interrupt configuration register</i> on page 89 for enable bits. See <i>ExCA card status-change register</i> on page 88 and the <i>ExCA interface status register</i> on page 85 for the status bits for this signal.  Status change. $\overline{\text{STSCHG}}$ is used to alert the system to a change in the READY, write protect, or battery voltage dead condition of a 16-bit I/O PC Card.  Ring indicate. $\overline{\text{RI}}$ is used by 16-bit modem cards to indicate a ring detection.
$\overline{\text{BVD2}}$ ( $\overline{\text{SPKR}}$ )	137	J15	71	W9	I	Battery voltage detect 2. BVD2 is generated by 16-bit memory PC Cards that include batteries. BVD2 is used with BVD1 as an indication of the condition of the batteries on a memory PC Card. Both BVD1 and BVD2 are high when the battery is good. When BVD2 is low and BVD1 is high, the battery is weak and should be replaced. When BVD1 is low, the battery is no longer serviceable and the data in the memory PC Card is lost. See <i>ExCA card status-change interrupt configuration register</i> on page 89 for enable bits. See <i>ExCA card status-change register</i> on page 88 and the <i>ExCA interface status register</i> on page 85 for the status bits for this signal.  Speaker. $\overline{\text{SPKR}}$ is an optional binary audio signal available only when the card and socket have been configured for the 16-bit I/O interface. The audio signals from cards A and B are combined by the PCI1221 and are output on SPKROUT.
$\overline{\text{CD1}}$ $\overline{\text{CD2}}$	82 140	V11 H17	16 74	H3 R9	I	PC Card detect 1 and PC Card detect 2. CD1 and CD2 are internally connected to ground on the PC Card. When a PC Card is inserted into a socket, CD1 and CD2 are pulled low. For signal status, see <i>interface status register</i> on page 88.
$\overline{\text{CE1}}$ $\overline{\text{CE2}}$	94 97	P13 R13	28 30	K6 L2	O	Card enable 1 and card enable 2. CE1 and CE2 enable even- and odd-numbered address bytes. $\overline{\text{CE1}}$ enables even-numbered address bytes, and $\overline{\text{CE2}}$ enables odd-numbered address bytes.
$\overline{\text{INPACK}}$	127	L14	61	R7	I	Input acknowledge. INPACK is asserted by the PC Card when it can respond to an I/O read cycle at the current address.
$\overline{\text{IORD}}$	99	W15	33	L5	O	I/O read. $\overline{\text{IORD}}$ is asserted by the PCI1221 to enable 16-bit I/O PC Card data output during host I/O read cycles.
$\overline{\text{IOWR}}$	101	V15	35	M2	O	I/O write. $\overline{\text{IOWR}}$ is driven low by the PCI1221 to strobe write data into 16-bit I/O PC Cards during host I/O write cycles.
$\overline{\text{OE}}$	98	U14	32	L6	O	Output enable. $\overline{\text{OE}}$ is driven low by the PCI1221 to enable 16-bit memory PC Card data output during host memory read cycles.

† Terminal name for slot A is preceded with A\_. For example, the full name for terminals 127 and L14 are A\_INPACK.

‡ Terminal name for slot B is preceded with B\_. For example, the full name for terminals 61 and R7 are B\_INPACK.

# PCI1221 GHK/PDV PC CARD CONTROLLERS

SCPS042 – JULY 1998

## Terminal Functions (Continued)

### 16-bit PC Card interface control (slots A and B) (continued)

NAME	TERMINAL PIN NUMBER				I/O TYPE	FUNCTION
	SLOT A†		SLOT B‡			
	PDV	GHK	PDV	GHK		
READY (IREQ)	135	J17	69	V8	I	Ready. The ready function is provided by READY when the 16-bit PC Card and the host socket are configured for the memory-only interface. READY is driven low by the 16-bit memory PC Cards to indicate that the memory card circuits are busy processing a previous write command. READY is driven high when the 16-bit memory PC Card is ready to accept a new data transfer command.  Interrupt request. IREQ is asserted by a 16-bit I/O PC Card to indicate to the host that a device on the 16-bit I/O PC Card requires service by the host software. IREQ is high (deasserted) when no interrupt is requested.
REG	130	K17	63	P8	O	Attribute memory select. REG remains high for all common memory accesses. When REG is asserted, access is limited to attribute memory (OE or WE active) and to the I/O space (IORD or IOWR active). Attribute memory is a separately accessed section of card memory and is generally used to record card capacity and other configuration and attribute information.
RESET	124	L18	58	W5	O	PC Card reset. RESET forces a hard reset to a 16-bit PC Card.
WAIT	136	J14	70	W8	I	Bus cycle wait. WAIT is driven by a 16-bit PC Card to delay the completion of (i.e., extend) the memory or I/O cycle in progress.
WE	110	R19	46	P3	O	Write enable. WE is used to strobe memory write data into 16-bit memory PC Cards. WE is also used for memory PC Cards that employ programmable memory technologies.
WP (IOIS16)	139	H18	73	U9	I	Write protect. WP applies to 16-bit memory PC Cards. WP reflects the status of the write-protect switch on 16-bit memory PC Cards. For 16-bit I/O cards, WP is used for the 16-bit port (IOIS16) function.  I/O is 16 bits. IOIS16 applies to 16-bit I/O PC Cards. IOIS16 is asserted by the 16-bit PC Card when the address on the bus corresponds to an address to which the 16-bit PC Card responds, and the I/O port that is addressed is capable of 16-bit accesses.
VS1 VS2	134 122	J18 M19	68 56	U8 P7	I/O	Voltage sense 1 and voltage sense 2. VS1 and VS2, when used in conjunction with each other, determine the operating voltage of the 16-bit PC Card.

† Terminal name for slot A is preceded with A\_. For example, the full name for terminals 110 and R19 are A\_WE.

‡ Terminal name for slot B is preceded with B\_. For example, the full name for terminals 46 and P3 are B\_WE.

Terminal Functions (Continued)

CardBus PC Card interface system (slots A and B)

NAME	TERMINAL PIN NUMBER				I/O TYPE	FUNCTION
	SLOT A†		SLOT B‡			
	PDV	GHK	PDV	GHK		
CCLK	112	P18	48	P6	O	CardBus PC Card clock. CCLK provides synchronous timing for all transactions on the CardBus interface. All signals except $\overline{\text{CRST}}$ , $\overline{\text{CCLKRUN}}$ , $\overline{\text{CINT}}$ , $\overline{\text{CSTSCHG}}$ , $\overline{\text{CAUDIO}}$ , $\overline{\text{CCD2-1}}$ , and $\overline{\text{CVS2-CVS1}}$ are sampled on the rising edge of CCLK, and all timing parameters are defined with the rising edge of this signal. CCLK operates at the PCI bus clock frequency, but it can be stopped in the low state or slowed down for power savings.
$\overline{\text{CCLKRUN}}$	139	H18	73	U9	O	CardBus PC Card clock run. $\overline{\text{CCLKRUN}}$ is used by a CardBus PC Card to request an increase in the CCLK frequency, and by the PCI1221 to indicate that the CCLK frequency is going to be decreased.
$\overline{\text{CRST}}$	124	L18	58	W5	I/O	CardBus PC Card reset. $\overline{\text{CRST}}$ is used to bring CardBus PC Card-specific registers, sequencers, and signals to a known state. When $\overline{\text{CRST}}$ is asserted, all CardBus PC Card signals must be 3-stated, and the PCI1221 drives these signals to a valid logic level. Assertion can be asynchronous to CCLK, but deassertion must be synchronous to CCLK.

† Terminal name for slot A is preceded with A\_. For example, the full name for terminals 112 and P18 are A\_CCLK.

‡ Terminal name for slot B is preceded with B\_. For example, the full name for terminals 48 and P6 are B\_CCLK.

# PCI1221 GHK/PDV PC CARD CONTROLLERS

SCPS042 – JULY 1998

## Terminal Functions (Continued)

### CardBus PC Card address and data (slots A and B)

NAME	TERMINAL PIN NUMBER				I/O TYPE	FUNCTION
	SLOT A <sup>†</sup>		SLOT B <sup>‡</sup>			
	PDV	GHK	PDV	GHK		
CAD31	147	F19	81	W11	I/O	PC Card address and data. These signals make up the multiplexed CardBus address and data bus on the CardBus interface. During the address phase of a CardBus cycle, CAD31–CAD0 contain a 32-bit address. During the data phase of a CardBus cycle, CAD31–CAD0 contain data. CAD31 is the most-significant bit.
CAD30	145	G17	79	R10		
CAD29	144	G18	78	U10		
CAD28	142	H15	77	V10		
CAD27	141	H14	76	W10		
CAD26	133	J19	67	R8		
CAD25	132	K14	66	W7		
CAD24	131	K15	65	V7		
CAD23	128	K19	62	W6		
CAD22	126	L15	60	V6		
CAD21	125	L17	59	U6		
CAD20	123	L19	57	V5		
CAD19	121	M18	55	R6		
CAD18	119	M15	54	U5		
CAD17	118	N19	53	W4		
CAD16	103	U15	37	M6		
CAD15	101	V15	35	M2		
CAD14	102	R14	36	M3		
CAD13	99	W15	33	L5		
CAD12	100	P14	34	M1		
CAD11	98	U14	32	L6		
CAD10	97	R13	30	L2		
CAD9	95	W14	29	L1		
CAD8	93	U13	27	K5		
CAD7	92	V13	26	K3		
CAD6	89	P12	23	J6		
CAD5	90	R12	24	K1		
CAD4	87	V12	20	J2		
CAD3	88	U12	21	J3		
CAD2	84	P11	18	H1		
CAD1	85	R11	19	J1		
CAD0	83	U11	17	H2		
<u>CC/BE3</u>	130	K17	63	P8	I/O	CardBus bus commands and byte enables. <u>CC/BE3–CC/BE0</u> are multiplexed on the same <u>CardBus</u> terminals. During the address phase of a CardBus cycle, <u>CC/BE3–CC/BE0</u> defines the bus command. During the data phase, this 4-bit bus is used as byte enables. The byte enables determine which byte paths of the full 32-bit data bus carry meaningful data. <u>CC/BE0</u> applies to byte 0 (CAD7–CAD0), <u>CC/BE1</u> applies to byte 1 (CAD15–CAD8), <u>CC/BE2</u> applies to byte 2 (CAD23–CAD8), and <u>CC/BE3</u> applies to byte 3 (CAD31–CAD24).
<u>CC/BE2</u>	117	N18	52	T1		
<u>CC/BE1</u>	104	W16	39	N1		
<u>CC/BE0</u>	94	P13	28	K6		
CPAR	106	R17	41	N3	I/O	CardBus parity. In all CardBus read and write cycles, the PCI1221 calculates even parity across the CAD and <u>CC/BE</u> buses. As an initiator during CardBus cycles, the PCI1221 outputs CPAR with a one-CCLK delay. As a target during CardBus cycles, the calculated parity is compared to the initiator's parity indicator; a compare error results in a parity error assertion.

<sup>†</sup> Terminal name for slot A is preceded with A\_. For example, the full name for terminals 106 and R17 are A\_CPAP.

<sup>‡</sup> Terminal name for slot B is preceded with B\_. For example, the full name for terminals 41 and N3 are B\_CPAP.

Terminal Functions (Continued)

CardBus PC Card interface control (slots A and B)

NAME	TERMINAL PIN NUMBER				I/O TYPE	FUNCTION
	SLOT A†		SLOT B‡			
	PDV	GHK	PDV	GHK		
CAUDIO	137	J15	71	W9	I	CardBus audio. CAUDIO is a digital input signal from a PC Card to the system speaker. The PCI1221 supports the binary audio mode and outputs a binary signal from the card to SPKROUT.
$\overline{\text{CBLOCK}}$	107	P15	42	N6	I/O	CardBus lock. $\overline{\text{CBLOCK}}$ is used to gain exclusive access to a target.
$\overline{\text{CCD1}}$ $\overline{\text{CCD2}}$	82 140	V11 H17	16 74	H3 R9	I	CardBus detect 1 and CardBus detect 2. $\overline{\text{CCD1}}$ and $\overline{\text{CCD2}}$ are used in conjunction with CVS1 and CVS2 to identify card insertion and interrogate cards to determine the operating voltage and card type.
$\overline{\text{CDEVSEL}}$	111	P17	47	R1	I/O	CardBus device select. The PCI1221 asserts $\overline{\text{CDEVSEL}}$ to claim a CardBus cycle as the target device. As a CardBus initiator on the bus, the PCI1221 monitors $\overline{\text{CDEVSEL}}$ until a target responds. If no target responds before timeout occurs, the PCI1221 terminates the cycle with an initiator abort.
$\overline{\text{CFRAME}}$	116	N17	51	R3	I/O	CardBus cycle frame. $\overline{\text{CFRAME}}$ is driven by the initiator of a CardBus bus cycle. $\overline{\text{CFRAME}}$ is asserted to indicate that a bus transaction is beginning, and data transfers continue while this signal is asserted. When $\overline{\text{CFRAME}}$ is deasserted, the CardBus bus transaction is in the final data phase.
$\overline{\text{CGNT}}$	110	R19	46	P3	I	CardBus bus grant. $\overline{\text{CGNT}}$ is driven by the PCI1221 to grant a CardBus PC Card access to the CardBus bus after the current data transaction has been completed.
$\overline{\text{CINT}}$	135	J17	69	V8	I	CardBus interrupt. $\overline{\text{CINT}}$ is asserted low by a CardBus PC Card to request interrupt servicing from the host.
$\overline{\text{CIRDY}}$	115	M14	50	P5	I/O	CardBus initiator ready. $\overline{\text{CIRDY}}$ indicates the CardBus initiator's ability to complete the current data phase of the transaction. A data phase is completed on a rising edge of CCLK when both $\overline{\text{CIRDY}}$ and $\overline{\text{CTRDY}}$ are asserted. Until $\overline{\text{CIRDY}}$ and $\overline{\text{CTRDY}}$ are both sampled asserted, wait states are inserted.
$\overline{\text{CPERR}}$	108	N14	43	P1	I/O	CardBus parity error. $\overline{\text{CPERR}}$ is used to report parity errors during CardBus transactions, except during special cycles. It is driven low by a target two clocks following that data when a parity error is detected.
$\overline{\text{CREQ}}$	127	L14	61	R7	I	CardBus request. $\overline{\text{CREQ}}$ indicates to the arbiter that the CardBus PC Card desires use of the CardBus bus as an initiator.
$\overline{\text{CSERR}}$	136	J14	70	W8	I	CardBus system error. $\overline{\text{CSERR}}$ reports address parity errors and other system errors that could lead to catastrophic results. $\overline{\text{CSERR}}$ is driven by the card synchronous to CCLK, but deasserted by a weak pullup, and may take several CCLK periods. The PCI1221 can report $\overline{\text{CSERR}}$ to the system by assertion of $\overline{\text{SERR}}$ on the PCI interface.
$\overline{\text{CSTOP}}$	109	R18	45	N5	I/O	CardBus stop. $\overline{\text{CSTOP}}$ is driven by a CardBus target to request the initiator to stop the current CardBus transaction. $\overline{\text{CSTOP}}$ is used for target disconnects, and is commonly asserted by target devices that do not support burst data transfers.
$\overline{\text{CSTSCHG}}$	138	H19	72	V9	I	CardBus status change. $\overline{\text{CSTSCHG}}$ is used to alert the system to a change in the card's status, and is used as a wake-up mechanism.
$\overline{\text{CTRDY}}$	114	P19	49	R2	I/O	CardBus target ready. $\overline{\text{CTRDY}}$ indicates the CardBus target's ability to complete the current data phase of the transaction. A data phase is completed on a rising edge of CCLK, when both $\overline{\text{CIRDY}}$ and $\overline{\text{CTRDY}}$ are asserted; until this time, wait states are inserted.
CVS1 CVS2	134 122	J18 M19	68 56	U8 P7	I/O	CardBus voltage sense 1 and CardBus voltage sense 2. CVS1 and CVS2 are used in conjunction with $\overline{\text{CCD1}}$ and $\overline{\text{CCD2}}$ to identify card insertion and interrogate cards to determine the operating voltage and card type.

† Terminal name for slot A is preceded with A\_. For example, the full name for terminals 137 and J15 are A\_CAUDIO.

‡ Terminal name for slot B is preceded with B\_. For example, the full name for terminals 71 and W9 are B\_CAUDIO.

# PCI1221 GHK/PDV PC CARD CONTROLLERS

SCPS042 – JULY 1998

## power supply sequencing

The PCI1221 contains 3.3-V I/O buffers with 5-V tolerance requiring a core power supply and clamping voltage. The core power supply is always 3.3 V. The clamp voltage can be either 3.3 V or 5 V, depending on the interface. The following power-up and power-down sequences are recommended.

The power-up sequence is:

1. Apply 3.3-V power to the core.
2. Assert  $\overline{PRST}$  to the device to disable the outputs during power up. Output drivers must be powered up in the high-impedance state to prevent high current levels through the clamp diodes to the 5-V supply.
3. Apply the clamping voltage.

The power-down sequence is:

1. Use  $\overline{PRST}$  to switch outputs to a high-impedance state.
2. Remove the clamping voltage.
3. Remove the 3.3-V power from the core.

## I/O characteristics

Figure 1 shows a 3-state bidirectional buffer. The *recommended operating conditions* table, on page 120, provides the electrical characteristics of the inputs and outputs.

### NOTE:

The PCI1221 meets the ac specifications of the 1997 PC Card Standard and PCI Local Bus Specification Rev. 2.2.

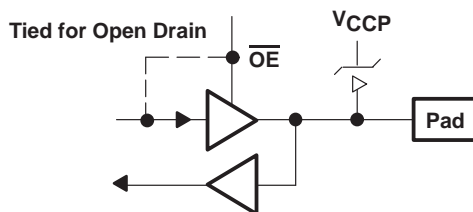

Figure 1. 3-State Bidirectional Buffer

### NOTE:

Unused pins (input or I/O) must be held high or low to prevent them from floating.

## clamping voltages

The clamping voltages are set to match whatever external environment the PCI1221 will be working with: 3.3 V or 5 V. The I/O sites can be pulled through a clamping diode to a voltage that protects the core from external signals. The core power supply is always 3.3 V and is independent of the clamping voltages. For example, PCI signaling can be either 3.3 V or 5 V, and the PCI1221 must reliably accommodate both voltage levels. This is accomplished by using a 3.3-V I/O buffer that is 5-V tolerant, with the applicable clamping voltage applied. If a system designer desires a 5-V PCI bus, VCCP can be connected to a 5-V power supply.

The PCI1221 requires four separate clamping voltages because it supports a wide range of features. The four voltages are listed and defined in the *recommended operating conditions*, on page 112.

---

## peripheral component interconnect (PCI) interface

The PCI1221 is fully compliant with the PCI Local Bus Specification Rev. 2.2. The PCI1221 provides all required signals for PCI master or slave operation, and may operate in either a 5-V or 3.3-V signaling environment by connecting the  $V_{CCP}$  terminals to the desired voltage level. In addition to the mandatory PCI signals, the PCI1221 provides the optional interrupt signals  $\overline{INTA}$  and  $\overline{INTB}$ .

### PCI bus lock (LOCK)

The bus-locking protocol defined in the PCI specification is not highly recommended, but is provided on the PCI1221 as an additional compatibility feature. The PCI  $\overline{LOCK}$  signal can be routed to the MFUNC4 terminal via the multifunction routing register, see the *multifunction routing register* description on page 62 for details. Note that the use of  $\overline{LOCK}$  is only supported by PCI-to-CardBus bridges in the downstream direction (away from the processor).

PCI  $\overline{LOCK}$  indicates an atomic operation that may require multiple transactions to complete. When  $\overline{LOCK}$  is asserted, nonexclusive transactions can proceed to an address that is not currently locked. A grant to start a transaction on the PCI bus does not guarantee control of  $\overline{LOCK}$ ; control of  $\overline{LOCK}$  is obtained under its own protocol. It is possible for different initiators to use the PCI bus while a single master retains ownership of  $\overline{LOCK}$ . Note that the CardBus signal for this protocol is  $\overline{CBLOCK}$  to avoid confusion with the bus clock.

An agent may need to do an exclusive operation because a critical access to memory might be broken into several transactions, but the master wants exclusive rights to a region of memory. The granularity of the lock is defined by PCI to be 16 bytes, aligned. The lock protocol defined by PCI allows a resource lock without interfering with nonexclusive real-time data transfer, such as video.

The PCI bus arbiter may be designed to support only complete bus locks using the  $\overline{LOCK}$  protocol. In this scenario, the arbiter will not grant the bus to any other agent (other than the  $\overline{LOCK}$  master) while  $\overline{LOCK}$  is asserted. A complete bus lock may have a significant impact on the performance of the video. The arbiter that supports complete bus lock must grant the bus to the cache to perform a writeback due to a snoop to a modified line when a locked operation is in progress.

The PCI1221 supports all  $\overline{LOCK}$  protocol associated with PCI-to-PCI bridges, as also defined for PCI-to-CardBus bridges. This includes disabling write posting while a locked operation is in progress, which can solve a potential deadlock when using devices such as PCI-to-PCI bridges. The potential deadlock can occur if a CardBus target supports delayed transactions and blocks access to the target until it completes a delayed read. This target characteristic is prohibited by the 2.2 PCI specification, and the issue is resolved by the PCI master using  $\overline{LOCK}$ .

### loading subsystem identification

The subsystem vendor ID register and subsystem ID register make up a doubleword of PCI configuration space located at offset 40h for functions 0 and 1. This doubleword register is used for system and option card (mobile dock) identification purposes and is required by some operating systems. Implementation of this unique identifier register is a PC 95 requirement.

The PCI1221 offers two mechanisms to load a read-only value into the subsystem registers. The first mechanism relies upon the system BIOS providing the subsystem ID value. The default access mode to the subsystem registers is read only, but can be made read/write by setting the SUBSYSRW bit in the system control register (bit 5, at PCI offset 80h). Once this bit is set, the BIOS can write a subsystem identification value into the registers at offset 40h. The BIOS must clear the SUBSYSRW bit such that the subsystem vendor ID register and subsystem ID register is limited to read-only access. This approach saves the added cost of implementing the serial electrically erasable programmable ROM (EEPROM).

# PCI1221 GHK/PDV PC CARD CONTROLLERS

SCPS042 – JULY 1998

## loading subsystem identification (continued)

In some conditions, such as in a docking environment, the subsystem vendor ID register and subsystem ID register must be loaded with a unique identifier via a serial EEPROM. The PCI1221 loads the data from the serial EEPROM after a reset of the primary bus. Note that the **SUSPEND** input gates the PCI reset from the entire PCI1221 core, including the serial bus state machine (see *suspend mode*, on page 40, for details on using **SUSPEND**).

The PCI1221 provides a two-line serial bus host controller that can be used to interface to a serial EEPROM. Refer to *serial bus interface* on page 29 for details on the two-wire serial bus controller and applications.

## PC Card applications

This section describes the PC Card interfaces of the PCI1221:

- Card insertion/removal and recognition
- P2C power-switch interface
- Zoom video support
- Speaker and audio applications
- LED socket activity indicators
- CardBus socket registers

## PC Card insertion/removal and recognition

The 1997 PC Card Standard addresses the card-detection and recognition process through an interrogation procedure that the socket must initiate on card insertion into a cold, nonpowered socket. Through this interrogation, card voltage requirements and interface (16 bit versus CardBus) are determined.

The scheme uses the  $\overline{CD1}$ ,  $\overline{CD2}$ ,  $\overline{VS1}$ , and  $\overline{VS2}$  signals ( $\overline{CCD1}$ ,  $\overline{CCD2}$ , CVS1, and CVS2 for CardBus). The configuration of these four terminals identifies the card type and voltage requirements of the PC Card interface. The encoding scheme is defined in the 1997 PC Card Standard and in Table 5.

**Table 5. PC Card Card-Detect and Voltage-Sense Connections**

$\overline{CD2}/\overline{CCD2}$	$\overline{CD1}/\overline{CCD1}$	$\overline{VS2}/\text{CVS2}$	$\overline{VS1}/\text{CVS1}$	KEY	INTERFACE	VOLTAGE
Ground	Ground	Open	Open	5 V	16-bit PC Card	5 V
Ground	Ground	Open	Ground	5 V	16-bit PC Card	5 V and 3.3 V
Ground	Ground	Ground	Ground	5 V	16-bit PC Card	5 V, 3.3 V, and X.X V
Ground	Ground	Open	Ground	LV	16-bit PC Card	3.3 V
Ground	Connect to CVS1	Open	Connect to $\overline{CCD1}$	LV	CardBus PC Card	3.3 V
Ground	Ground	Ground	Ground	LV	16-bit PC Card	3.3 V and X.X V
Connect to CVS2	Ground	Connect to $\overline{CCD2}$	Ground	LV	CardBus PC Card	3.3 V and X.X V
Connect to CVS1	Ground	Ground	Connect to $\overline{CCD2}$	LV	CardBus PC Card	3.3 V, X.X V, and Y.Y V
Ground	Ground	Ground	Open	LV	16-bit PC Card	Y.Y V
Connect to CVS2	Ground	Connect to $\overline{CCD2}$	Open	LV	CardBus PC Card	Y.Y V
Ground	Connect to CVS2	Connect to $\overline{CCD1}$	Open	LV	CardBus PC Card	X.X V and Y.Y V
Connect to CVS1	Ground	Open	Connect to $\overline{CCD2}$	LV	CardBus PC Card	Y.Y V
Ground	Connect to CVS1	Ground	Connect to $\overline{CCD1}$		Reserved	
Ground	Connect to CVS2	Connect to $\overline{CCD1}$	Ground		Reserved	



## P<sup>2</sup>C power-switch interface (TPS2202A/2206)

The PCI1221 provides a P<sup>2</sup>C (PCMCIA Peripheral Control) interface for control of the PC Card power switch. The CLOCK, DATA, and LATCH terminals interface with the TI TPS2202A/2206 dual-slot PC Card power interface switches to provide power switch support. Figure 2 shows the terminal assignments of the TPS2206, and Figure 3 illustrates a typical application where the PCI1221 represents the PCMCIA controller.

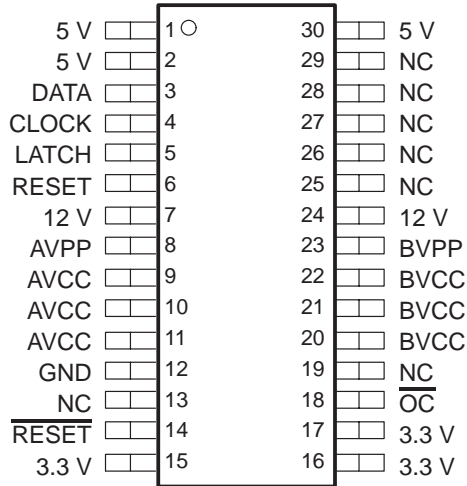

NC – No internal connection

**Figure 2. TPS2206 Terminal Assignments**

The CLOCK terminal on the PCI1221 can be an input or an output. The PCI1221 defaults the CLOCK terminal as an input to control the serial interface and the internal state machine. The P2CCLK bit in the system control register can be set by the platform BIOS to enable the PCI1221 to generate and drive the CLOCK internally from the PCI clock. When the system design implements CLOCK as an output from the PCI1221, an external pull down is required.

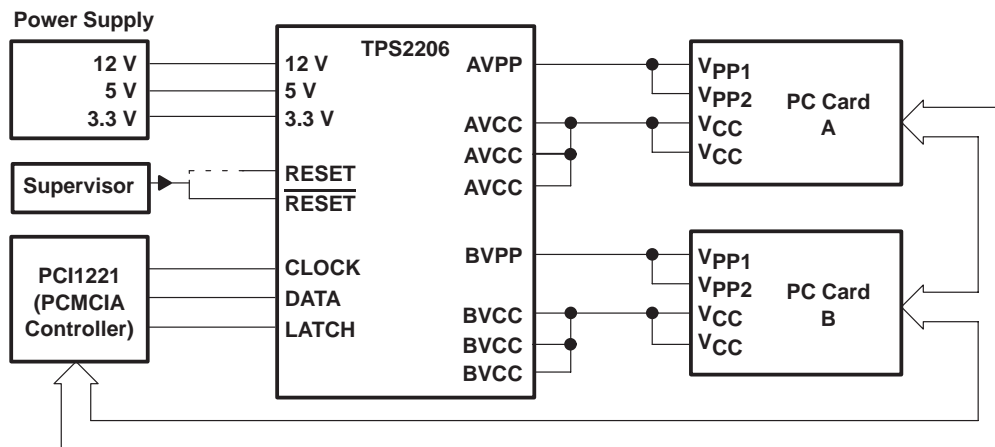

**Figure 3. TPS2206 Typical Application**

# PCI1221 GHK/PDV PC CARD CONTROLLERS

SCPS042 – JULY 1998

## zoom video support

The PCI1221 allows for the implementation of zoom video for PC Cards. Zoom video is supported by setting the ZVENABLE bit in the card control register on a per socket function basis. Setting this bit puts PC Card-16 address lines A25–A4 of the PC Card interface in the high-impedance state. These lines can then be used to transfer video and audio data directly to the appropriate controller. Card address lines A3-A0 can still be used to access PC Card CIS registers for PC Card configuration. Figure 4 illustrates a PCI1221 ZV implementation.

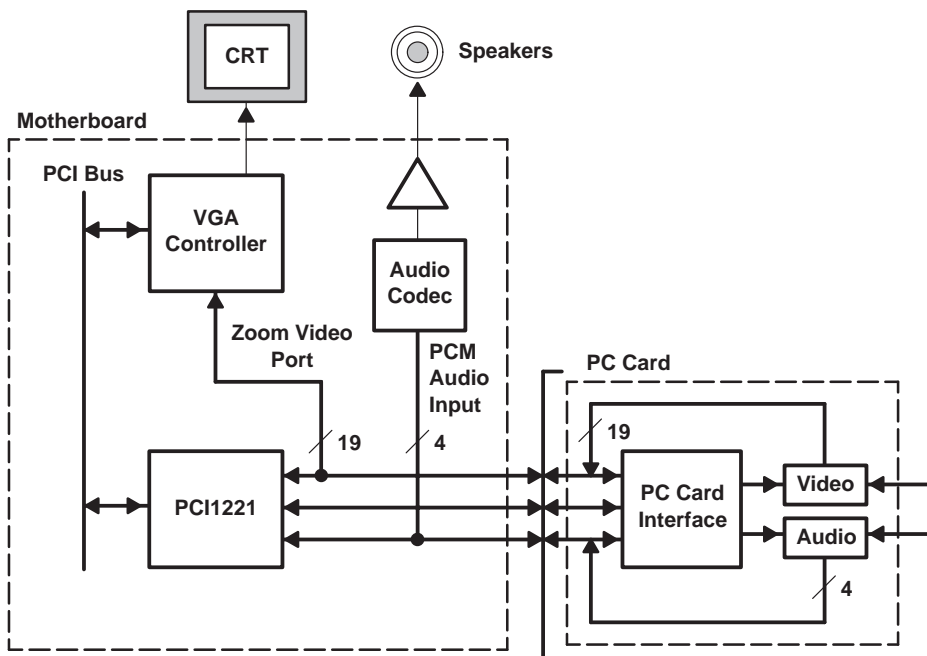

Figure 4. Zoom Video Implementation Using PCI1221

Not shown in Figure 4 is the multiplexing scheme used to route either socket 0 or socket 1 ZV source to the graphics controller. The PCI1221 provides ZVSTAT,  $\overline{\text{ZVSEL0}}$ , and  $\overline{\text{ZVSEL1}}$  signals on the multifunction terminals to switch external bus drivers. Figure 5 shows an implementation for switching between three ZV streams using external logic.

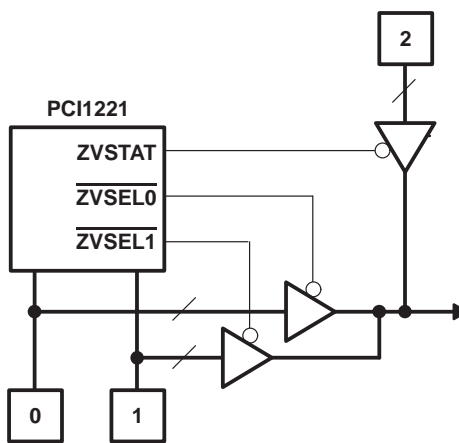

Figure 5. Zoom Video Switching Application

**zoom video support (continued)**

Figure 5 illustrates an implementation using standard three-state bus drivers with active-low output enables.  $\overline{ZVSEL0}$  is an active-low output indicating that the Socket 0 ZV mode is enabled, and  $\overline{ZVSEL1}$  is an active-low output indicating that Socket 1 ZV is enabled. When both sockets have ZV mode enabled, the PCI1221 defaults to indicating socket 0 enabled through  $\overline{ZVSEL0}$ ; however, the PORTSEL bit in the card control register allows software to select the socket ZV source priority. Table 6 illustrates the functionality of the ZV output signals.

**Table 6. PC Card Card-Detect and Voltage-Sense Connections**

INPUTS			OUTPUTS		
PORTSEL	SOCKET 0 ENABLE	SOCKET 1 ENABLE	$\overline{ZVSEL0}$	$\overline{ZVSEL1}$	ZVSTAT
X	0	0	1	1	0
0	1	X	0	1	1
0	0	1	1	0	1
1	X	1	1	0	1
1	1	0	0	1	1

Also shown in Figure 5 is a third ZV source that may be provided from a source such as a high-speed serial bus like IEEE1394. The ZVSTAT signal provides a mechanism to switch the third ZV source. ZVSTAT is an active-high output indicating that one of the PCI1221 sockets is enabled for ZV mode. The implementation shown in Figure 5 can be used if PC Card ZV is prioritized over other sources.

**SPKROUT and CAUDPWM usage**

SPKROUT carries the digital audio signal from the PC Card to the system. When a 16-bit PC Card is configured for I/O mode, the BVD2 pin becomes  $\overline{SPKR}$ . This terminal is also used in CardBus binary audio applications, and is referred to as CAUDIO.  $\overline{SPKR}$  passes a TTL level digital audio signal to the PCI1221. The CardBus CAUDIO signal also can pass a single-amplitude binary waveform. The binary audio signals from the two PC Card Sockets are XOR'ed in the PCI1221 to produce SPKROUT. This output is enabled by the SPKROUTEN bit in the card control register.

Older controllers support CAUDIO in binary or PWM mode but use the same pin (SPKROUT). Some audio chips may not support both modes on one pin and may have a separate pin for binary and PWM. The PCI1221 implementation includes a signal for PWM, CAUDPWM, which can be routed to a MFUNC terminal. The AUD2MUX bit located in the card control register is programmed on a per socket function basis to route a CardBus CAUDIO PWM terminal to CAUDPWM. If both CardBus functions enable CAUDIO PWM routing to CAUDPWM, then socket 0 audio takes precedence. Refer to the *multifunction routing register* description on page 62 for details on configuring the MFUNC terminals.

Figure 6 provides an illustration of a sample application using SPKROUT and CAUDPWM.

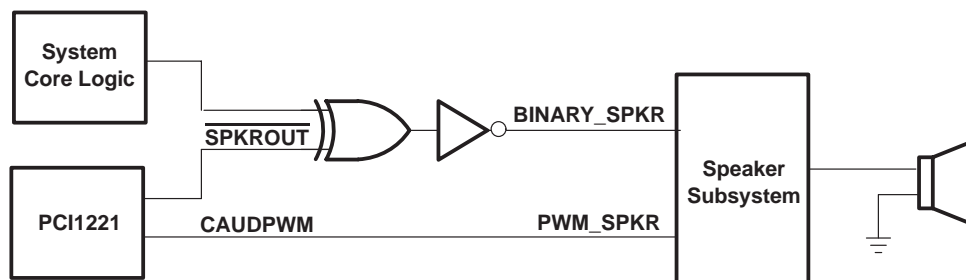

**Figure 6. Sample Application of SPKROUT and CAUDPWM**

# PCI1221 GHK/PDV PC CARD CONTROLLERS

SCPS042 – JULY 1998

## LED socket activity indicators

The socket activity LEDs are provided to indicate when a PC Card is being accessed. The LEDA1 and LEDA2 signals can be routed to the multifunction terminals. When configured for LED outputs, these terminals output an active high signal to indicate socket activity. LEDA1 indicates socket 0 (card A) activity, and LEDA2 indicates socket 1 (card B) activity. The LED\_SKT output indicates socket activity to either socket 0 or socket 1. Refer to the *multifunction routing register* description on page 62 for details on configuring the multifunction terminals.

The LED signal is active high and is driven for 64-ms durations. When the LED is not being driven high, it is driven to a low state. Either of the two circuits shown in Figure 7 can be implemented to provide LED signaling, and it is left for the board designer to implement the circuit that best fits the application.

The LED activity signals are valid when a card is inserted, powered, and not in reset. For PC Card 16, the LED activity signals are pulsed when  $\overline{\text{READY}}/\overline{\text{IREQ}}$  is low. For CardBus cards, the LED activity signals are pulsed if  $\overline{\text{CFRAME}}$ ,  $\overline{\text{IRDY}}$ , or  $\overline{\text{CREQ}}$  are active.

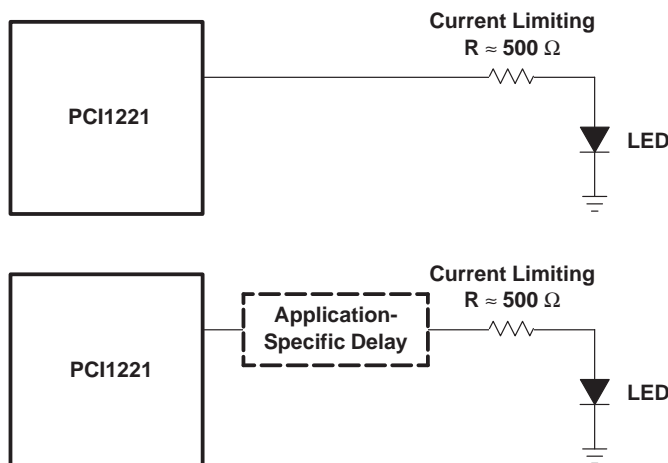

Figure 7. Two Sample LED Circuits

As indicated, the LED signals are driven for a period of 64 ms by a counter circuit. To avoid the possibility of the LEDs appearing to be stuck when the PCI clock is stopped, the LED signaling is cut-off when the  $\overline{\text{SUSPEND}}$  signal is asserted, when the PCI clock is to be stopped during the clock run protocol, or when in the D2 or D1 power state.

If any additional socket activity occurs during this counter cycle, the counter is reset and the LED signal remains driven. If socket activity is frequent (at least once every 64 ms), the LED signals remain driven.

## CardBus socket registers

The PCI1221 contains all registers for compatibility with the latest PCI-to-PCMCIA CardBus bridge specification. These registers exist as the CardBus socket registers, and are listed in Table 7.

**Table 7. CardBus Socket Registers**

REGISTER NAME	OFFSET
Socket event	00h
Socket mask	04h
Socket present state	08h
Socket force event	0Ch
Socket control	10h
Reserved	14h
Reserved	18h
Reserved	1Ch
Socket power management	20h

### serial bus interface

The PCI1221 provides a serial bus interface to load subsystem identification and select register defaults through a serial EEPROM and to provide a PC Card power switch interface alternative to P<sup>2</sup>C. Refer to *P<sup>2</sup>C power-switch interface (TPS2202A/2206)* on page 25 for details. The PCI1221 serial bus interface is compatible with various I<sup>2</sup>C and SMBus components.

### serial bus interface implementation

The PCI1221 defaults to serial bus interface are disabled. To enable the serial interface, a pulldown resistor must be implemented on the LATCH terminal and the appropriate pullup must be implemented on the SDA and SCL signals, i.e. the MFUNC1 and MFUNC4 terminals. When the interface is detected, the SBDETECT bit in the system control register is set. The SBDETECT bit is cleared by a write back of 1.

The PCI1221 implements a two pin serial interface with one clock signal (SCL) and one data signal (SDA). When a pulldown is provided on the LATCH terminal, the SCL signal is mapped to the MFUNC4 terminal and the SDA signal is mapped to the MFUNC1 terminal. The PCI1221 drives SCL at nearly 100 kHz during data transfers, which is the maximum specified frequency for standard mode I<sup>2</sup>C. An example application implementing the two-wire serial bus is illustrated in Figure 8.

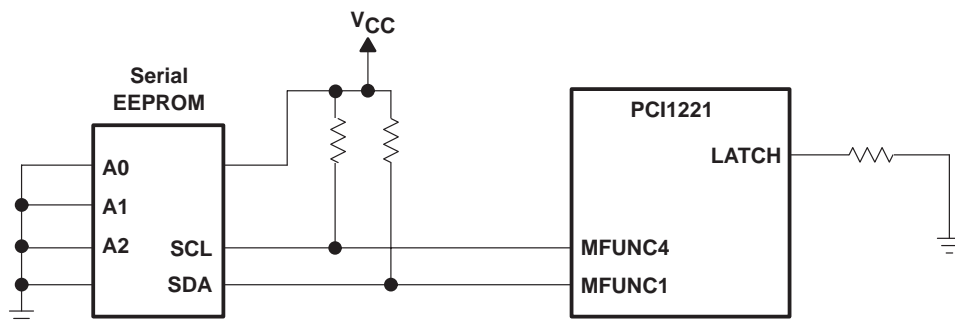

**Figure 8. Serial EEPROM Application**

Some serial device applications may include PC Card power switches, ZV source switches, card ejectors, or other devices that may enhance the user's PC Card experience. The serial EEPROM device and PC Card power switches are discussed in the sections that follow.

### serial bus interface protocol

The SCL and SDA signals are bidirectional, open-drain signals and require pullup resistors as shown in Figure 8. The PCI1221 supports up to 100 Kb/s data transfer rate and is compatible with standard mode I<sup>2</sup>C using seven-bit addressing.

# PCI1221 GHK/PDV PC CARD CONTROLLERS

SCPS042 – JULY 1998

## serial bus interface protocol (continued)

All data transfers are initiated by the serial bus master. The beginning of a data transfer is indicated by a start condition, which is signalled when the SDA line transitions to low state while SCL is in the high state, as illustrated in Figure 9. The end of a requested data transfer is indicated by a stop condition, which is signalled by a low to high transition of SDA while SCL is in the high state, as shown in Figure 9. Data on SDA must remain stable during the high state of the SCL signal, as changes on the SDA signal during the high state of SCL are interpreted as control signals, that is, a start or a stop condition.

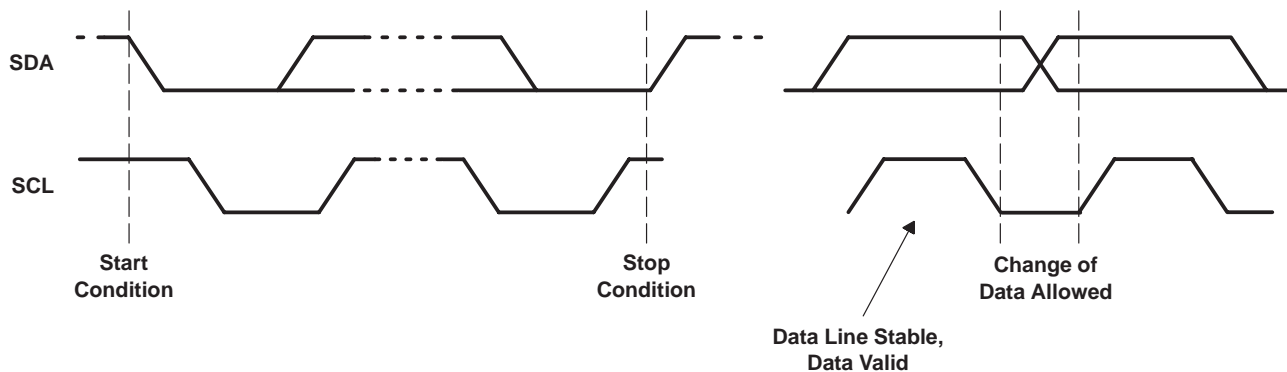

Figure 9. Serial Bus Start/Stop Conditions and Bit Transfers

Data is transferred serially in 8-bit bytes. The number of bytes that may be transmitted during a data transfer is unlimited, however, each byte must be completed with an acknowledge bit. An acknowledge (ACK) is indicated by the receiver pulling the SDA signal low so that it remains low during the high state of the SCL signal. The acknowledge protocol is illustrated in Figure 10.

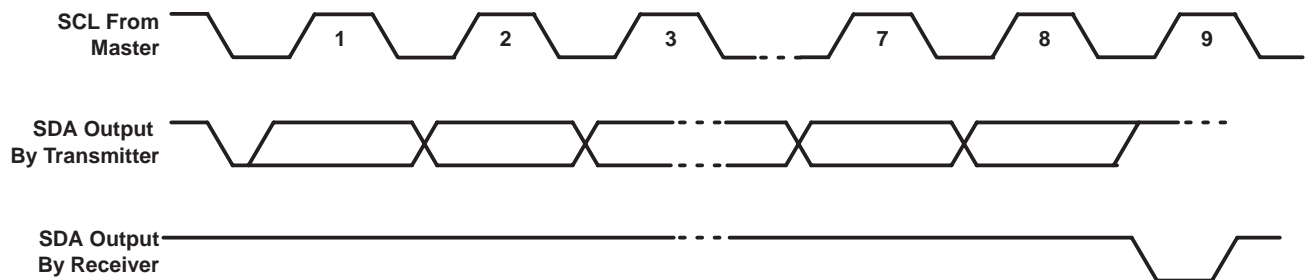

Figure 10. Serial Bus Protocol Acknowledge

The PCI1221 is a serial bus master; all other devices connected to the serial bus external to the PCI1221 are slave devices. As the bus master, the PCI1221 drives the SCL clock at nearly 100 kHz during bus cycles and three-states SCL (zero frequency) during idle states.

Typically, the PCI1221 masters byte reads and byte writes under software control. Doubleword reads are performed by the serial EEPROM initialization circuitry upon a PCI reset and may not be generated under software control. Refer to *serial bus EEPROM application* on page 32 for details on how the PCI1221 automatically loads the subsystem identification and other register defaults through a serial bus EEPROM.

A byte write is illustrated in Figure 11. The PCI1221 issues a start condition and sends the seven bit slave device address and the command bit zero. A zero in the R/W command bit indicates that the data transfer is a write. The slave device acknowledges if it recognizes the address. If there is no acknowledgment received by the PCI1221, then an appropriate status bit is set in the serial bus control and status register. The word address byte is then sent by the PCI1221 and another slave acknowledgment is expected. Then the PCI1221 delivers the data byte MSB first and expects a final acknowledgment before issuing the stop condition.

serial bus interface protocol (continued)

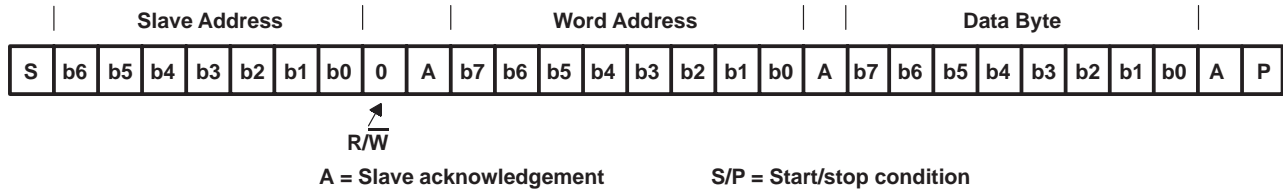

Figure 11. Serial Bus Protocol – Byte Write

A byte read is illustrated in Figure 12. The read protocol is very similar to the write protocol except the  $\overline{R/W}$  command bit must be set to one to indicate a read-data transfer. In addition, the PCI1221 master must acknowledge reception of the read bytes from the slave transmitter. The slave transmitter drives the SDA signal during read data transfers. The SCL signal remains driven by the PCI1221 master.

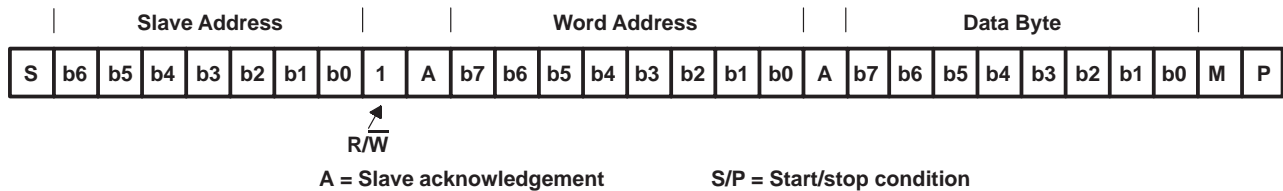

Figure 12. Serial Bus Protocol – Byte Read

Figure 13 illustrates EEPROM interface doubleword data collection protocol.

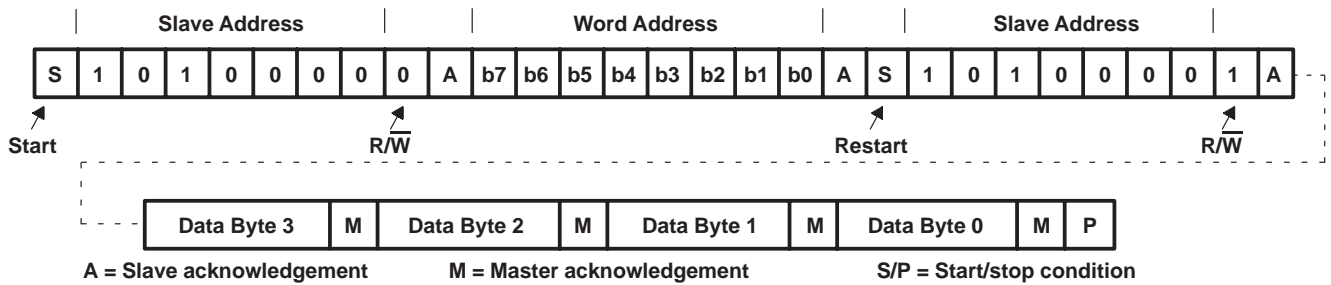

Figure 13. EEPROM Interface doubleword Data Collection

# PCI1221 GHK/PDV PC CARD CONTROLLERS

SCPS042 – JULY 1998

## serial bus EEPROM application

When the PCI bus is reset and the serial bus interface is detected, the PCI1221 attempts to read the subsystem identification and other register defaults from a serial EEPROM. The registers and corresponding bits that may be loaded with defaults through the EEPROM are provided in Table 8.

**Table 8. Registers and Bits Loadable Through Serial EEPROM**

PCI OFFSET	OFFSET REFERENCE	REGISTER	BITS LOADED FROM EEPROM
40h	01h	Subsystem identification	31–0
80h	02h	System control register	31–29, 27, 26, 24, 15, 14, 6–3, 1
8Ch	03h	Multifunction routing register	27–0
90h	04h	Retry status, Card control, device control, diagnostic	31, 28–24, 22, 19–16, 15, 13, 7, 6

The EEPROM data format is detailed in Figure 14. This format must be followed for the PCI1221 to properly load initializations from a serial EEPROM. Any undefined condition results in a terminated load and sets the ROM\_ERR bit in the serial bus control and status register.

Slave Address = 1010 000

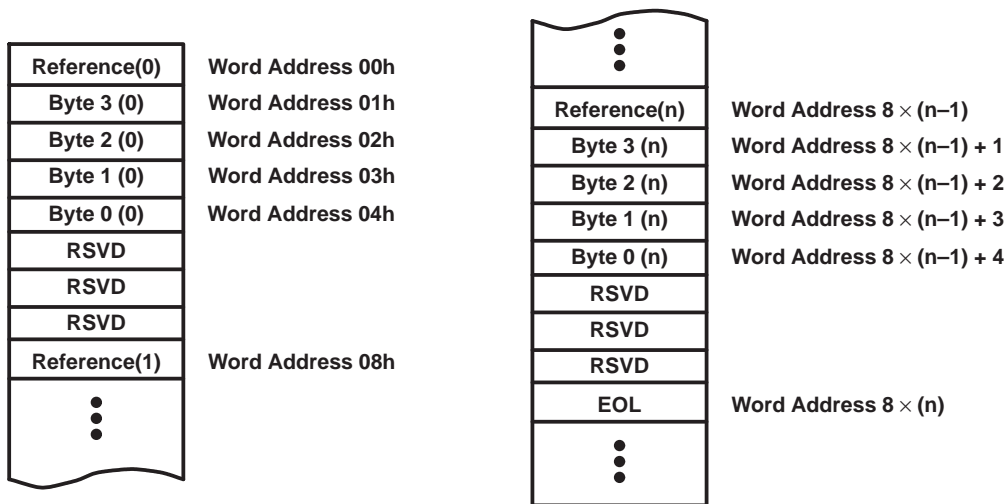

**Figure 14. EEPROM Data Format**

The byte at the EEPROM word address 00h must either contain a valid PCI offset, as listed in Table 8, or an end-of-list (EOL) indicator. The EOL indicator is a byte value of FFh, and indicates the end of the data to load from the EEPROM. Only doubleword registers are loaded from the EEPROM, and all bit fields must be considered when programming the EEPROM.

The serial EEPROM is addressed at slave address 1010000b by the PCI1221. All hardware address bits for the EEPROM should be tied to the appropriate level to achieve this address. The serial EEPROM chip in the sample application circuit (Figure 8) assumes the 1010b high address nibble. The lower three address bits are terminal inputs to the chip, and the sample application shows these terminal inputs tied to GND.

When a valid offset reference is read, four bytes are read from the EEPROM, MSB first, as illustrated in Figure 13. The address autoincrements after every byte transfer according to the doubleword read protocol. Note that the word addresses align with the data format illustrated in Figure 14. The PCI1221 continues to load data from the serial EEPROM until an end-of-list indicator is read. Three reserved bytes are stuffed to maintain eight byte data structures.



**serial bus EEPROM application (continued)**

Note, the eight-byte data structure is important to provide correct addressing per the doubleword read format shown in Figure 13. In addition, the reference offsets must be loaded in the EEPROM in sequential order, that is 01h, 02h, 03h, 04h. If the offsets are not sequential, the registers may be loaded incorrectly.

**serial bus power switch application**

The PCI1221 does not automatically control a serial bus power switch transparently to host software as it does for P<sup>2</sup>C power switches. But, the PCI1221 serial bus interface can be used in conjunction with the power status,  $\overline{GPE}$ , output, and support software to control a serial bus power switch. If a serial bus power switch interface is implemented, a pulldown resistor must be provided on the PCI1221 CLOCK terminal to reduce power consumption.

The PCI1221 supports two common SMBus data write protocols, write byte and send byte formats. The write byte protocol using a word address of 00h is discussed in *serial bus interface protocol* on page 29. The send byte protocol is shown in Figure 15 using a slave address '101001x'. The PROT\_SEL bit in the serial bus control and status register, see Table 37 on page 79, allows the serial bus interface to operate with the send byte protocol. For more information on programming the serial bus interface, refer to *accessing serial bus devices through software*.

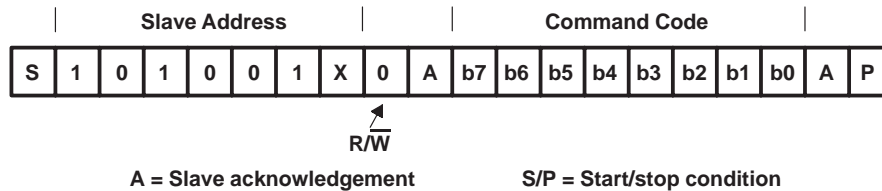

**Figure 15. Send Byte Protocol**

The power switch may support an interrupt mode to indicate over current or other power switch related events. The PCI1221 does not implement logic to respond to these events, but does implement a flexible general purpose interface to control these events through ACPI and other handlers. Refer to *Advanced Configuration and Power Interface Specification* for details on implementing the PCI1221 in an ACPI system.

**accessing serial bus devices through software**

The PCI1221 provides a programming mechanism to control serial bus devices through software. The programming is accomplished through a doubleword of PCI configuration space at offset B0h. Table 9 lists the registers used to program a serial bus device through software.

**Table 9. PCI1221 Registers Used to Program Serial Bus Devices**

PCI OFFSET	REGISTER NAME	DESCRIPTION
B0H	Serial bus data	Contains the data byte to send on write commands or the received data byte on read commands.
B1H	Serial bus index	The content of this register is sent as the word address on byte writes or reads. This register is not used in the quick command protocol.
B2H	Serial bus slave address	Write transactions to this register initiate a serial bus transaction. The slave device address and the R/W command selector are programmed through this register.
B3H	Serial bus control and status	Read data valid, general busy, and general error status are communicated through this register. In addition, the protocol select bit is programmed through this register.

# PCI1221 GHK/PDV PC CARD CONTROLLERS

SCPS042 – JULY 1998

---

## programmable interrupt subsystem

Interrupts provide a way for I/O devices to let the microprocessor know that they require servicing. The dynamic nature of PC Cards, and the abundance of PC Card I/O applications require substantial interrupt support from the PCI1221. The PCI1221 provides several interrupt signaling schemes to accommodate the needs of a variety of platforms. The different mechanisms for dealing with interrupts in this device are based on various specifications and industry standards. The ExCA register set provides interrupt control for some 16-bit PC Card functions, and the CardBus socket register set provides interrupt control for the CardBus PC Card functions. The PCI1221 is, therefore, backward compatible with existing interrupt control register definitions, and new registers have been defined where required.

The PCI1221 detects PC Card interrupts and events at the PC Card interface and notifies the host controller using one of several interrupt signaling protocols. To simplify the discussion of interrupts in the PCI1221, PC Card interrupts are classified as either card status change (CSC) or as functional interrupts.

The method by which any type of PCI1221 interrupt is communicated to the host interrupt controller varies from system to system. The PCI1221 offers system designers the choice of using parallel PCI interrupt signaling, parallel ISA-type IRQ interrupt signaling, or the IRQSER serialized ISA and/or PCI interrupt protocol. It is possible to use the parallel PCI interrupts in combination with either parallel IRQs or serialized IRQs, as detailed in the sections that follow. All interrupt signalling is provided through the seven multifunction terminals, MFUNC0–6.

## PC Card functional and card status change interrupts

PC Card functional interrupts are defined as requests from a PC Card application for interrupt service and are indicated by asserting specially-defined signals on the PC Card interface. Functional interrupts are generated by 16-bit I/O PC Cards and by CardBus PC Cards.

Card status change (CSC)-type interrupts are defined as events at the PC Card interface that are detected by the PCI1221 and may warrant notification of host card and socket services software for service. CSC events include both card insertion and removal from PC Card sockets, as well as transitions of certain PC Card signals.

Table 10 summarizes the sources of PC Card interrupts and the type of card associated with them. CSC and functional interrupt sources are dependent on the type of card inserted in the PC Card socket. The three types of cards that can be inserted into any PC Card socket are:

- 16-bit memory card
- 16-bit I/O card
- CardBus cards

PC Card functional and CSC interrupts (continued)

Table 10. Interrupt Mask and Flag Registers

CARD TYPE	EVENT	MASK	FLAG
16-bit memory	Battery conditions (BVD1, BVD2)	ExCA offset 05h/45h/805h bits 1 and 0	ExCA offset 04h/44h/804h bits 1 and 0
	Wait states (READY)	ExCA offset 05h/45h/805h bit 2	ExCA offset 04h/44h/804h bit 2
16-bit I/O	Change in card status (STSCHG)	ExCA offset 05h/45h/805h bit 0	ExCA offset 04h/44h/804h bit 0
	Interrupt request (IREQ)	Always enabled	PCI configuration offset 91h bit 0
All 16-bit PC Cards	Power cycle complete	ExCA offset 05h/45h/805h bit 3	ExCA offset 04h/44h/804h bit 3
CardBus	Change in card status (CSTSCHG)	Socket mask bit 0	Socket event bit 0
	Interrupt request (CINT)	Always enabled	PCI configuration offset 91h bit 0
	Power cycle complete	Socket mask bit 3	Socket event bit 3
	Card insertion or removal	Socket mask bits 2 and 1	Socket event bits 2 and 1

Functional interrupt events are valid only for 16-bit I/O and CardBus cards; that is, the functional interrupts are not valid for 16-bit memory cards. Furthermore, card insertion and removal-type CSC interrupts are independent of the card type.

Table 11. PC Card Interrupt Events and Description

CARD TYPE	EVENT	TYPE	SIGNAL	DESCRIPTION
16-bit memory	Battery conditions (BVD1, BVD2)	CSC	$\overline{\text{BVD1}}(\overline{\text{STSCHG}})/\overline{\text{CSTSCHG}}$	A transition on BVD1 indicates a change in the PC Card battery conditions.
			$\overline{\text{BVD2}}(\overline{\text{SPKR}})/\overline{\text{CAUDIO}}$	A transition on BVD2 indicates a change in the PC Card battery conditions.
	Wait states (READY)	CSC	$\overline{\text{READY}}(\overline{\text{IREQ}})/\overline{\text{CINT}}$	A transition on READY indicates a change in the ability of the memory PC Card to accept or provide data.
16-bit I/O	Change in card status (STSCHG)	CSC	$\overline{\text{BVD1}}(\overline{\text{STSCHG}})/\overline{\text{CSTSCHG}}$	The assertion of $\overline{\text{STSCHG}}$ indicates a status change on the PC Card.
	Interrupt request (IREQ)	Functional	$\overline{\text{READY}}(\overline{\text{IREQ}})/\overline{\text{CINT}}$	The assertion of $\overline{\text{IREQ}}$ indicates an interrupt request from the PC Card.
CardBus	Change in card status (CSTSCHG)	CSC	$\overline{\text{BVD1}}(\overline{\text{STSCHG}})/\overline{\text{CSTSCHG}}$	The assertion of $\overline{\text{CSTSCHG}}$ indicates a status change on the PC Card.
	Interrupt request (CINT)	Functional	$\overline{\text{READY}}(\overline{\text{IREQ}})/\overline{\text{CINT}}$	The assertion of $\overline{\text{CINT}}$ indicates an interrupt request from the PC Card.
All PC Cards	Card insertion or removal	CSC	$\overline{\text{CD1}}/\overline{\text{CCD1}}, \overline{\text{CD2}}/\overline{\text{CCD2}}$	A transition on either $\overline{\text{CD1}}/\overline{\text{CCD1}}$ or $\overline{\text{CD2}}/\overline{\text{CCD2}}$ indicates an insertion or removal of a 16-bit or CardBus PC Card.
	Power cycle complete	CSC	N/A	An interrupt is generated when a PC Card power-up cycle has completed.

# PCI1221 GHK/PDV PC CARD CONTROLLERS

SCPS042 – JULY 1998

---

## PC Card functional and CSC interrupts (continued)

The naming convention for PC Card signals describes the function for 16-bit memory, I/O cards, and CardBus. For example,  $\overline{\text{READY}}(\overline{\text{IREQ}})/\overline{\text{CINT}}$  includes  $\overline{\text{READY}}$  for 16-bit memory cards,  $\overline{\text{IREQ}}$  for 16-bit I/O cards, and  $\overline{\text{CINT}}$  for CardBus cards. The 16-bit memory card signal name is first, with the I/O card signal name second, enclosed in parentheses. The CardBus signal name follows after a forward double slash (/).

The PC Card standard describes the power-up sequence that must be followed by the PCI1221 when an insertion event occurs and the host requests that the socket  $V_{CC}$  and  $V_{PP}$  be powered. Upon completion of this power-up sequence, the PCI1221 interrupt scheme can be used to notify the host system (see Table 11), denoted by the power cycle complete event. This interrupt source is considered a PCI1221 internal event because it depends on the completion of applying power to the socket rather than on a signal change at the PC Card interface.

## interrupt masks and flags

Host software may individually mask (or disable) most of the potential interrupt sources listed in Table 11 by setting the appropriate bits in the PCI1221. By individually masking the interrupt sources listed, software can control those events that cause a PCI1221 interrupt. Host software has some control over the system interrupt the PCI1221 asserts by programming the appropriate routing registers. The PCI1221 allows host software to route PC Card CSC and PC Card functional interrupts to separate system interrupts. Interrupt routing somewhat specific to the interrupt signaling method used is discussed in more detail in the following sections.

When an interrupt is signaled by the PCI1221, the interrupt service routine must determine which of the events listed in Table 10 caused the interrupt. Internal registers in the PCI1221 provide flags that report the source of an interrupt. By reading these status bits, the interrupt service routine can determine the action to be taken.

Table 10 details the registers and bits associated with masking and reporting potential interrupts. All interrupts can be masked except the functional PC Card interrupts, and an interrupt status flag is available for all types of interrupts.

Notice that there is not a mask bit to stop the PCI1221 from passing PC Card functional interrupts through to the appropriate interrupt scheme. These interrupts are not valid until the card is properly powered, and there should never be a card interrupt that does not require service after proper initialization.

Various methods of clearing the interrupt flag bits are listed in Table 10. The flag bits in the ExCA registers (16-bit PC Card-related interrupt flags) can be cleared using two different methods. One method is an explicit write of 1 to the flag bit to clear, and the other is by reading the flag bit register. The selection of flag bit clearing is made by bit 2 in the global control register (ExCA offset 1Eh/5Eh/81Eh), and defaults to the *flag cleared on read* method.

The CardBus-related interrupt flags can be cleared by an explicit write of 1 to the interrupt flag in the socket event register. Although some of the functionality is shared between the CardBus registers and the ExCA registers, software should not program the chip through both register sets when a CardBus card is functioning.

## using parallel IRQ interrupts

The seven multifunction terminals, MFUNC6:0, implemented in the PCI1221 may be routed to obtain a subset of the ISA IRQs. The IRQ choices provide ultimate flexibility in PC Card host interruptions. To use the parallel ISA type IRQ interrupt signaling, software must program the device control register, located at PCI offset 92h, to select the parallel IRQ signaling scheme. Refer to the *multifunction routing register* description on page 62 for details on configuring the multifunction terminals.

A system using parallel IRQs requires (at a minimum) one PCI terminal,  $\overline{\text{INTA}}$ , to signal CSC events. This requirement is dictated by certain card and socket services software. The  $\overline{\text{INTA}}$  requirement calls for routing the MFUNC0 terminal for  $\overline{\text{INTA}}$  signaling. The INTRTIE bit is used, in this case, to route socket 1 interrupt events to  $\overline{\text{INTA}}$ . This leaves (at a maximum) six different IRQs to support legacy 16-bit PC Card functions.

**using parallel IRQ interrupts (continued)**

As an example, suppose the six IRQs used by legacy PC Card applications are IRQ3, IRQ4, IRQ5, IRQ10, IRQ11, and IRQ15. The multifunction control register must be programmed to a value of 0x0FBA5432. This value routes the MFUNC0 terminal to  $\overline{INTA}$  signaling and routes the remaining terminals as illustrated in Figure 16. Not shown is that  $\overline{INTA}$  must also be routed to the programmable interrupt controller (PIC), or to some circuitry that provides parallel PCI interrupts to the host.

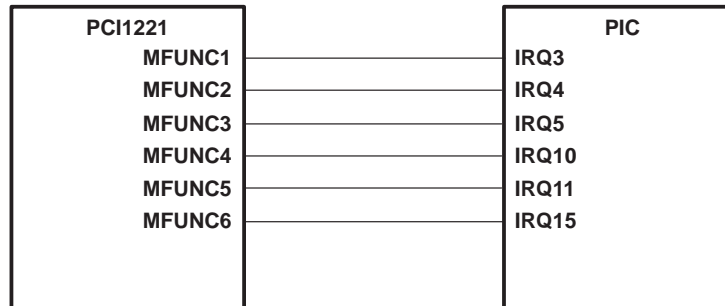

**Figure 16. IRQ Implementation**

Power-on software is responsible for programming the multifunction routing register to reflect the IRQ configuration of a system implementing the PCI1221. The multifunction routing register is shared between the two PCI1221 functions, and only one write to function 0 or 1 is necessary to configure the MFUNC6:0 signals. Writing to only function 0 is recommended. Refer to the *multifunction routing register* description on page 62 for details on configuring the multifunction terminals.

The parallel ISA type IRQ signaling from the MFUNC6:0 terminals is compatible with those input directly into the 8259 PIC. The parallel IRQ option is provided for system designs that require legacy ISA IRQs. Design constraints may demand more MFUNC6:0 IRQ terminals than the PCI1221 makes available. A system designer may choose to implement an IRQSER deserializer companion chip, such as the Texas Instruments PCI950. To use a deserializer, the MFUNC3 terminal must be configured as IRQSER and connected to the deserializer, which outputs all 15 ISA IRQ's and four PCI interrupts as decoded from the IRQSER stream.

**using parallel PCI interrupts**

Parallel PCI interrupts are available when exclusively in parallel PCI interrupt mode parallel ISA IRQ signaling mode, and when only IRQs are serialized with the IRQSER protocol. Both  $\overline{INTA}$  and  $\overline{INTB}$  can be routed to MFUNC terminals (MFUNC0 and MFUNC1). However, both socket functions' interrupts can be routed to  $\overline{INTA}$  (MFUNC0) if the INTRTIE bit is set in the system control register.

The INTRTIE bit effects the read-only value provided through accesses to the interrupt pin register. When INTRTIE bit is set, both functions return a value of 0x01 on reads from the interrupt pin register for both parallel and serial PCI interrupts. The interrupt signalling modes are summarized in Table 12.

# PCI1221 GHK/PDV PC CARD CONTROLLERS

SCPS042 – JULY 1998

## using parallel PCI interrupts (continued)

**Table 12. Interrupt Pin Register Cross Reference**

INTERRUPT SIGNALING MODE	INTRTIE BIT	INTPIN FUNCTION 0	INTPIN FUNCTION 1
Parallel PCI interrupts only	0	0x01 ( $\overline{\text{INTA}}$ )	0x02 ( $\overline{\text{INTB}}$ )
Parallel IRQ and parallel PCI interrupts	0	0x01 ( $\overline{\text{INTA}}$ )	0x02 ( $\overline{\text{INTB}}$ )
IRQ serialized (IRQSER) and parallel PCI interrupts	0	0x01 ( $\overline{\text{INTA}}$ )	0x02 ( $\overline{\text{INTB}}$ )
IRQ and PCI serialized (IRQSER) interrupts (default)	0	0x01 ( $\overline{\text{INTA}}$ )	0x02 ( $\overline{\text{INTB}}$ )
Parallel PCI interrupts only	1	0x01 ( $\overline{\text{INTA}}$ )	0x01 ( $\overline{\text{INTA}}$ )
Parallel IRQ and parallel PCI interrupts	1	0x01 ( $\overline{\text{INTA}}$ )	0x01 ( $\overline{\text{INTA}}$ )
IRQ serialized (IRQSER) and parallel PCI interrupts†	1	0x01 ( $\overline{\text{INTA}}$ )	0x01 ( $\overline{\text{INTA}}$ )
IRQ and PCI serialized (IRQSER) interrupts†	1	0x01 ( $\overline{\text{INTA}}$ )	0x01 ( $\overline{\text{INTA}}$ )

† When configuring the PCI1221 functions to share PCI interrupts, multifunction terminal MFUNC3 must be configured as IRQSER prior to setting the INTRTIE bit.

## using serialized IRQSER interrupts

The serialized interrupt protocol implemented in the PCI1221 uses a single terminal to communicate all interrupt status information to the host controller. The protocol defines a serial packet consisting of a start cycle, multiple interrupt indication cycles, and a stop cycle. All data in the packet is synchronous with the PCI clock. The packet data describes sixteen parallel ISA IRQ signals and the optional four PCI interrupts  $\overline{\text{INTA}}$ ,  $\overline{\text{INTB}}$ ,  $\overline{\text{INTC}}$ , and  $\overline{\text{INTD}}$ . For details on the IRQSER protocol refer to the document *Serialized IRQ Support for PCI Systems*.

## SMI support in the PCI1221

The PCI1221 provides a mechanism for interrupting the system when power changes have been made to the PC Card socket interfaces. The interrupt mechanism is designed to fit into a system maintenance interrupt (SMI) scheme. SMI interrupts are generated by the PCI1221, when enabled, after a write cycle to either the socket control register of the CardBus register set or the power control register of the ExCA register set causes a power cycle change sequence sent on the power switch interface.

The SMI control is programmed through 3 bits in the system control register. These bits are SMIRROUTE, SMISTATUS, and SMIENB. The SMI control bits function as described in Table 13.

**Table 13. SMI Control**

BIT NAME	FUNCTION
SMIRROUTE	This shared bit controls whether the SMI interrupts are sent as a CSC interrupt or as IRQ2.
SMISTAT	This socket dependent bit is set when an SMI interrupt is pending. This status flag is cleared by writing back a 1.
SMIENB	When set, SMI interrupt generation is enabled. This bit is shared by functions 0 and 1.

If CSC SMI interrupts are selected, then the SMI interrupt is sent as the CSC on a per socket basis. The CSC interrupt can be either level or edge mode, depending upon the CSCMODE bit in the ExCA global control register.

If IRQ2 is selected by SMIRROUTE, the IRQSER signaling protocol supports SMI signaling in the IRQ2 IRQ/Data slot. In a parallel ISA IRQ system, the support for an active low IRQ2 is provided only if IRQ2 is routed to either MFUNC3 or MFUNC6 through the multifunction routing register.

---

## power management overview

TI has expended great effort to provide a high-performance device with low power consumption. In addition to the low-power CMOS technology process used for the PCI1221, various features are designed into the device to allow implementation of popular power-saving techniques. These features and techniques are discussed in this section.

### clock run protocol

The PCI  $\overline{\text{CLKRUN}}$  feature is the primary method of power management on the PCI interface of the PCI1221.  $\overline{\text{CLKRUN}}$  signalling is provided through the MFUNC6 terminal. Since some chip sets do not implement  $\overline{\text{CLKRUN}}$ , this is not always available to the system designer, and alternate power savings features are provided. For details on the  $\overline{\text{CLKRUN}}$  protocol refer to the *PCI Mobile Design Guide*.

The PCI1221 does not permit the central resource to stop the PCI clock under any of the following conditions:

- The KEEPCLK bit in the system control register is set.
- The PC Card-16 resource manager is busy.
- The PCI1221 CardBus master state machine is busy. A cycle may be in progress on CardBus.
- The PCI1221 master is busy. There may be posted data from CardBus to PCI in the PCI1221.
- There are pending interrupts.
- The CardBus CCLK for either socket has not been stopped by the PCI1221  $\overline{\text{CLKRUN}}$  manager.

The PCI1221 restarts the PCI clock using the  $\overline{\text{CLKRUN}}$  protocol under any of the following conditions:

- A PC Card-16 IREQ or a CardBus  $\overline{\text{CINT}}$  has been asserted by either card.
- A CardBus wakeup (CSTSCHG) or PC Card-16  $\overline{\text{STSCHG/RI}}$  event occurs in either socket.
- A CardBus attempts to start the CCLK using  $\overline{\text{CCLKRUN}}$ .
- A CardBus card arbitrates for the CardBus bus using  $\overline{\text{CREQ}}$ .

### CardBus PC card power management

The PCI1221 implements its own card power management engine that can be used to turn off the CCLK to a socket when there is no activity to the CardBus PC Card. The PCI clock-run protocol is followed on the CardBus  $\overline{\text{CCLKRUN}}$  interface to control this clock management.

### 16-Bit PC card power mManagement

The COE and PWRDOWN bits in the ExCA registers are provided for 16-bit PC Card power management. The COE bit three states the card interface to save power. The power savings when using this feature are minimal. The COE bit will reset the PC Card when used, and the PWRDOWN bit will not. Furthermore, the PWRDOWN bit is an automatic COE, that is, the PWRDOWN performs the COE function when there is no card activity.

**NOTE:**

The 16-bit PC Card must implement the proper pullup resistors for the COE and PWRDOWN modes.

# PCI1221 GHK/PDV PC CARD CONTROLLERS

SCPS042 – JULY 1998

## suspend mode

The  $\overline{\text{SUSPEND}}$  signal provides backward compatibility and gates the PCI reset ( $\overline{\text{PRST}}$ ) signal from the PCI1221. However, additional functionality has been defined for  $\overline{\text{SUSPEND}}$  to provide additional power-management options.

$\overline{\text{SUSPEND}}$  provides a mechanism to gate the PCLK from the PCI1221, as well as gate  $\overline{\text{PRST}}$ . This can potentially save power while in an idle state; however, it requires substantial design effort to implement. Some issues to consider are:

- What if cards are present in the sockets?
- What if the cards in the sockets are powered?
- How to pass CSC (insertion/removal) events.

Even without the PCI clock to the PCI1221 core, asynchronous-type functions (such as  $\overline{\text{RI\_OUT}}$ ) can pass CSC events, wake-up events, etc., back to the system. If a system designer chooses to not pass card removal events through to the system, then the PCI1221 would not be able to power down the empty socket without the power switch clock (CLOCK) generated externally. Refer to the P2C power switch interface for details. Figure 17 is a functional implementation diagram.

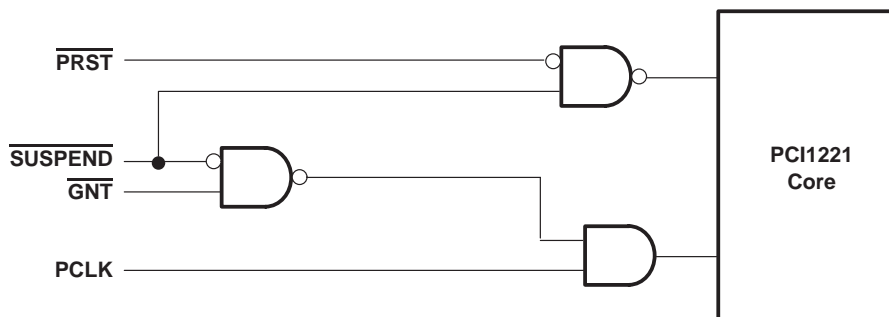

Figure 17.  $\overline{\text{SUSPEND}}$  Functional Implementation

Figure 18 is a signal diagram of the suspend function.



suspend mode (continued)

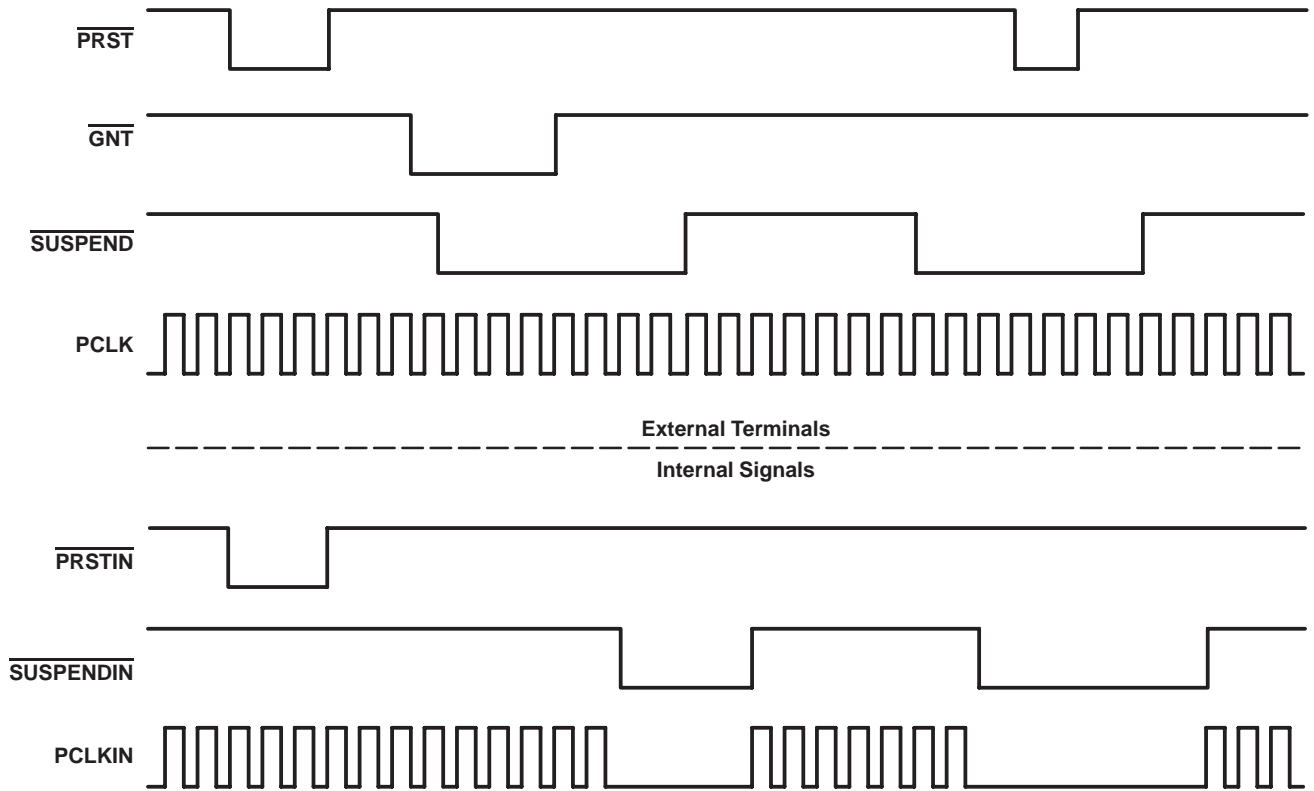

Figure 18. Signal Diagram of Suspend Function

ring indicate

The  $\overline{\text{RI\_OUT}}$  output is an important feature in power management, allowing a system to go into a suspended mode and wake up on modem rings and other card events. TI designed flexibility permits this signal to fit wide platform requirements.  $\overline{\text{RI\_OUT}}$  on the PCI1221 can be asserted under any of the following conditions:

- A 16-bit PC Card modem in a powered socket asserts  $\overline{\text{RI}}$  to indicate to the system the presence of an incoming call.
- A powered down CardBus card asserts  $\text{CSTSCHG}$  (CBWAKE) requesting system and interface wake up.
- A CSC event occurs, such as insertion/removal of cards, battery voltage levels.

$\text{CSTSCHG}$  from a powered CardBus card is indicated as a CSC event, not as a CBWAKE event. These two  $\overline{\text{RI\_OUT}}$  events are enabled separately. Figure 15 shows various enable bits for the PCI1221  $\overline{\text{RI\_OUT}}$  function; however, it does not show the masking of CSC events. See Table 10 for a detailed description of CSC interrupt masks and flags.

# PCI1221 GHK/PDV PC CARD CONTROLLERS

SCPS042 – JULY 1998

ring indicate (continued)

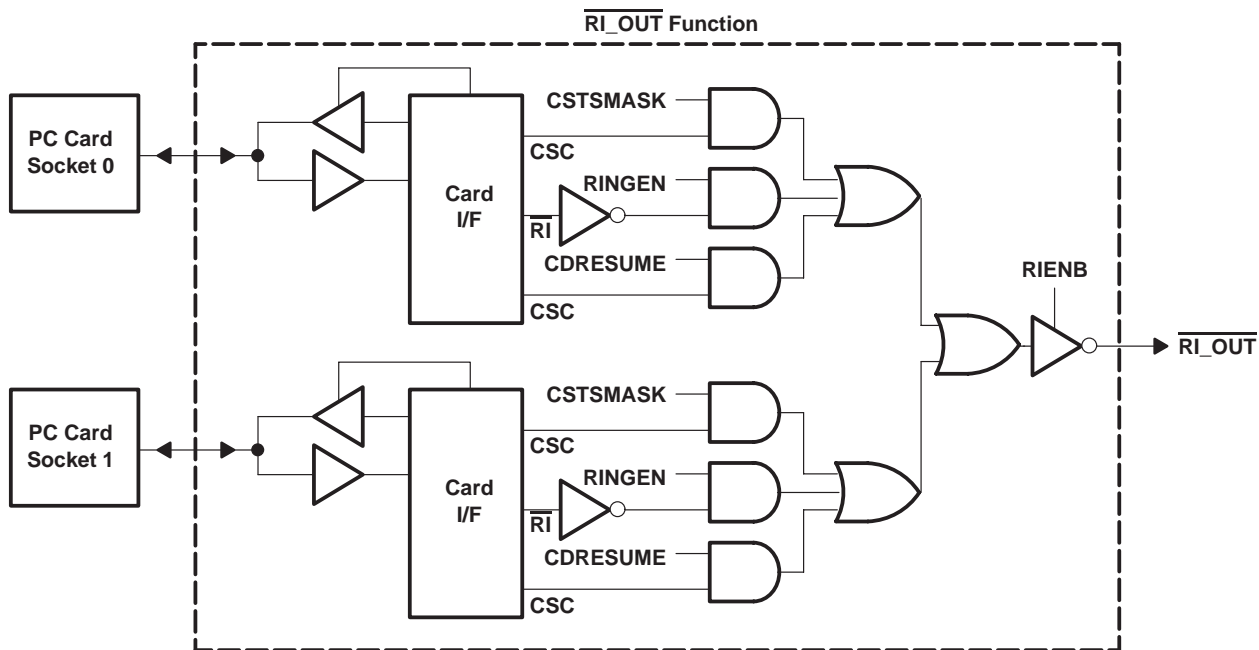

Figure 19.  $\overline{RI\_OUT}$  Functional Diagram

$\overline{RI}$  from the 16-bit PC Card interface is masked by the ExCA control bit RINGEN in the interrupt and general control register. This is programmed on a per-socket basis and is only applicable when a 16-bit card is powered in the socket.

The CBWAKE signaling to  $\overline{RI\_OUT}$  is enabled through the same mask as the CSC event for CSTSCHG. The mask bit, CSTSMASK, is programmed through the socket mask register in the CardBus socket registers.

## PCI power management (PCIPM)

The PCI power-management (PCIPM) specification establishes the infrastructure required to let the operating system control the power of PCI functions. This is done by defining a standard PCI interface and operations to manage the power of PCI functions on the bus. The PCI bus and the PCI functions can be assigned one of four software-visible power-management states that result in varying levels of power savings.

The four power-management states of PCI functions are:

- D0 - Fully-on state
- D1 and D2 - Intermediate states
- D3 - Off state

Similarly, bus power states of the PCI bus are B0-B3. The bus power states B0-B3 are derived from the device power state of the originating bridge device.

For the operating system (OS) to power manage the device power states on the PCI bus, the PCI function should support four power-management operations. These operations are:

- Capabilities reporting
- Power status reporting
- Setting the power state
- System wake up

**PCI power management (PCIPM) (continued)**

The OS identifies the capabilities of the PCI function by traversing the new capabilities list. The presence of new capabilities is indicated by a 1 in the capabilities list (CAPLIST) bit in the status register (bit 4) and providing access to a capabilities list.

The capabilities pointer provides access to the first item in the linked list of capabilities. For the PCI1221, a CardBus bridge with PCI configuration space header type 2, the capabilities pointer is mapped to an offset of 14h. The first byte of each capability register block is required to be a unique ID of that capability. PCI power management has been assigned an ID of 01h. The next byte is a pointer to the next pointer item in the list of capabilities. If there are no more items in the list, the next item pointer should be set to 0. The registers following the next item pointer are specific to the function’s capability. The PCIPM capability implements the register block outlined in Table 14.

**Table 14. Power-Management Registers**

REGISTER NAME			OFFSET
Power-management capabilities		Next item pointer	0
Data	PMCSR bridge support extensions	Power-management control status (CSR)	4

The power management capabilities register is a static read-only register that provides information on the capabilities of the function related to power management. The PMCSR register enables control of power-management states and enables/monitors power-management events. The data register is an optional register that can provide dynamic data.

For more information on PCI power management refer to the *PCI Bus Power Management Interface Specification*.

**ACPI support**

The ACPI specification provides a mechanism that allows unique pieces of hardware to be described to the ACPI driver. The PCI1221 offers a generic interface that is compliant with ACPI design rules.

Two doublewords of general purpose ACPI programming bits reside in PCI1221 PCI configuration space at offset A8h. The programming model is broken into status and control functions. In compliance with ACPI, the top level event status and enable bits reside in GPE\_STS and GPE\_EN registers. The status and enable bits are implemented as defined by ACPI, and illustrated in Figure 20.

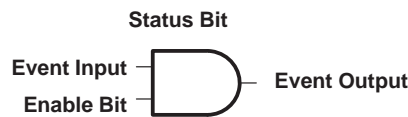

**Figure 20. Block Diagram of a Status/Enable Cell**

The status and enable bits are used to generate an event that allows the ACPI driver to call a control method associated with the pending status bit. The control method can then control the hardware by manipulating the hardware control bits or by investigating child status bits and calling their respective control methods. A hierarchical implementation would be somewhat limiting, however, as upstream devices would have to remain in some level of power state to report events.

For more information of ACPI refer to the *Advanced Configuration and Power Interface Specification*.

# PCI1221 GHK/PDV PC CARD CONTROLLERS

SCPS042 – JULY 1998

## PC Card controller programming model

This section describes the PCI1221 PCI configuration registers that make up the 256-byte PCI configuration header for each PCI1221 function. As noted, some bits are global in nature and should be accessed only through function 0.

## PCI configuration registers (functions 0 and 1)

The PCI1221 is a multifunction PCI device, and the PC Card controller is integrated as PCI functions 0 and 1. The configuration header is compliant with the PCI specification as a CardBus bridge header and is PC 99 compliant as well. Table 15 shows the PCI configuration header, which includes both the predefined portion of the configuration space and the user-definable registers.

**Table 15. PCI Configuration Registers (Functions 0 and 1)**

REGISTER NAME				OFFSET
Device ID		Vendor ID		00h
Status		Command		04h
Class code			Revision ID	08h
BIST	Header type	Latency timer	Cache line size	0Ch
CardBus socket/ExCA base address				10h
Secondary status		Reserved	Capability pointer	14h
CardBus latency timer	Subordinate bus number	CardBus bus number	PCI bus number	18h
CardBus Memory base register 0				1Ch
CardBus Memory limit register 0				20h
CardBus Memory base register 1				24h
CardBus Memory limit register 1				28h
CardBus I/O base register 0				2Ch
CardBus I/O limit register 0				30h
CardBus I/O base register 1				34h
CardBus I/O limit register 1				38h
Bridge control		Interrupt pin	Interrupt line	3Ch
Subsystem ID		Subsystem vendor ID		40h
PC Card 16-bit I/F legacy-mode base address				44h
Reserved				48h–7Ch
System control				80h
Reserved				84h–88h
Multifunction routing				8Ch
Diagnostic	Device control	Card control	Retry status	90h
Reserved				94h–9Fh
Power-management capabilities		Next-item pointer	Capability ID	A0h
PM data	PMCSR bridge support extensions	Power-management control/status		A4h
General-purpose event enable		General-purpose event status		A8h
General-purpose output		General-purpose input		ACh
Serial bus control/status	Serial bus slave address	Serial bus index	Serial bus data	B0h
Reserved				B4h–FCh

# PCI1221 GHK/PDV PC CARD CONTROLLERS

SCPS042 – JULY 1998

## vendor ID register

Bit	15	14	13	12	11	10	9	8	7	6	5	4	3	2	1	0
Name	Vendor ID															
Type	R	R	R	R	R	R	R	R	R	R	R	R	R	R	R	R
Default	0	0	0	1	0	0	0	0	0	1	0	0	1	1	0	0

Register: **Vendor ID**

Type: Read only

Offset: 00h (functions 0, 1)

Default: 104Ch

Description: This 16-bit read-only register contains a value allocated by the PCI SIG (special interest group) and identifies the manufacturer of the PCI device. The vendor ID assigned to TI is 104Ch.

## device ID register

Bit	15	14	13	12	11	10	9	8	7	6	5	4	3	2	1	0
Name	Device ID															
Type	R	R	R	R	R	R	R	R	R	R	R	R	R	R	R	R
Default	1	0	1	0	1	1	0	0	0	0	0	1	1	0	0	1

Register: **Device ID**

Type: Read only

Offset: 02h (functions 0, 1)

Default: AC19h

Description: This 16-bit read-only register contains a value assigned to the PCI1221 by TI. The device identification for the PCI1221 is AC19h.

## command register

Bit	15	14	13	12	11	10	9	8	7	6	5	4	3	2	1	0
Name	Command															
Type	R	R	R	R	R	R	R	R/W	R	R/W	R	R	R	R/W	R/W	R/W
Default	0	0	0	0	0	0	0	0	0	0	0	0	0	0	0	0

Register: **Command**

Type: Read only, read/write (see individual bit descriptions)

Offset: 04h

Default: 0000h

Description: The command register provides control over the PCI1221 interface to the PCI bus. All bit functions adhere to the definitions in PCI Local Bus Specification 2.2. None of the bit functions in this register are shared between the two PCI1221 PCI functions. Two command registers exist in the PCI1221, one for each function. Software must manipulate the two PCI1221 functions as separate entities when enabling functionality through the command register. The SERR\_EN and PERR\_EN enable bits in this register are internally wired-OR between the two functions, and these control bits appear separately according to their software function. See Table 16 for the complete description of the register contents.

# PCI1221 GHK/PDV PC CARD CONTROLLERS

SCPS042 – JULY 1998

**Table 16. Command Register**

BIT	SIGNAL	TYPE	FUNCTION
15–10	RSVD	R	Reserved. Bits 15–10 are read only and return 0s when read. Write transactions have no effect.
9	FBB_EN	R	Fast back-to-back enable. The PCI1221 does not generate fast back-to-back transactions; therefore, bit 9 is read only and returns 0s when read.
8	SERR_EN	R/W	System Error ( $\overline{\text{SERR}}$ ) enable. Bit 8 controls the enable for the $\overline{\text{SERR}}$ driver on the PCI interface. $\overline{\text{SERR}}$ can be asserted after detecting an address parity error on the PCI bus. Both bit 8 and bit 6 must be set for the PCI1221 to report address parity errors. 0 = Disable $\overline{\text{SERR}}$ output driver (default) 1 = Enable $\overline{\text{SERR}}$ output driver
7	STEP_EN	R	Address/data stepping control. The PCI1221 does not support address/data stepping, and bit 7 is hardwired to 0. Write transactions to this bit have no effect.
6	PERR_EN	R/W	Parity error response enable. Bit 6 controls the PCI1221's response to parity errors through $\overline{\text{PERR}}$ . Data parity errors are indicated by asserting $\overline{\text{PERR}}$ , whereas address parity errors are indicated by asserting $\overline{\text{SERR}}$ . 0 = PCI1221 ignores detected parity error (default) 1 = PCI1221 responds to detected parity errors
5	VGA_EN	R	VGA palette snoop. Bit 5 controls how PCI devices handle accesses to video graphics array (VGA) palette registers. The PCI1221 does not support VGA palette snooping; therefore, this bit is hardwired to 0. Bit 5 is read only and returns 0 when read. Write transactions to this bit have no effect.
4	MWI_EN	R	Memory write and invalidate enable. Bit 4 controls whether a PCI initiator device can generate memory write and Invalidate commands. The PCI1221 controller does not support memory write and invalidate commands, it uses memory write commands instead; therefore, this bit is hardwired to 0. Bit 4 is read only and returns 0 when read. Write transactions to this bit have no effect.
3	SPECIAL	R	Special cycles. Bit 3 controls whether or not a PCI device ignores PCI special cycles. The PCI1221 does not respond to special cycle operations; therefore, this bit is hardwired to 0. Bit 3 is read only and returns 0 when read. Write transactions to this bit have no effect.
2	MAST_EN	R/W	Bus master control. Bit 2 controls whether or not the PCI1221 can act as a PCI bus initiator (master). The PCI1221 can take control of the PCI bus only when this bit is set. 0 = Disables the PCI1221's ability to generate PCI bus accesses (default) 1 = Enables the PCI1221's ability to generate PCI bus accesses
1	MEM_EN	R/W	Memory space enable. Bit 1 controls whether or not the PCI1221 can claim cycles in PCI memory space. 0 = Disables the PCI1221's response to memory space accesses (default) 1 = Enables the PCI1221's response to memory space accesses
0	IO_EN	R/W	I/O space control. Bit 0 controls whether or not the PCI1221 can claim cycles in PCI I/O space. 0 = Disables the PCI1221 from responding to I/O space accesses (default) 1 = Enables the PCI1221 to respond to I/O space accesses

# PCI1221 GHK/PDV PC CARD CONTROLLERS

SCPS042 – JULY 1998

## status register

Bit	15	14	13	12	11	10	9	8	7	6	5	4	3	2	1	0
Name	Status															
Type	R/C	R/C	R/C	R/C	R/C	R	R	R/C	R	R	R	R	R	R	R	R
Default	0	0	0	0	0	0	1	0	0	0	0	1	0	0	0	0

Register: **Status**

Type: Read only, read/clear (see individual bit descriptions)

Offset: 06h (functions 0, 1)

Default: 0210h

Description: The status register provides device information to the host system. Bits in this register may be read normally. A bit in the status register is reset when a 1 is written to that bit location; a 0 written to a bit location has no effect. All bit functions adhere to the definitions in the PCI Local Bus Specification 2.2. PCI bus status is shown through each function. See Table 17 for the complete description of the register contents.

**Table 17. Status Register**

BIT	SIGNAL	TYPE	FUNCTION
15	PAR_ERR	R/C	Detected parity error. Bit 15 is set when a parity error is detected (either address or data).
14	SYS_ERR	R/C	Signaled system error. Bit 14 is set when SERR is enabled and the PCI1221 signals a system error to the host.
13	MABORT	R/C	Received master abort. Bit 13 is set when a cycle initiated by the PCI1221 on the PCI bus has been terminated by a master abort.
12	TABT_REC	R/C	Received target abort. Bit 12 is set when a cycle initiated by the PCI1221 on the PCI bus was terminated by a target abort.
11	TABT_SIG	R/C	Signaled target abort. Bit 11 is set by the PCI1221 when it terminates a transaction on the PCI bus with a target abort.
10–9	PCI_SPEED	R	DEVSEL timing. These read-only bits encode the timing of DEVSEL and are hardwired 01b, indicating that the PCI1221 asserts PCI_SPEED at a medium speed on nonconfiguration cycle accesses.
8	DATAPAR	R/C	Data parity error detected. 0 = The conditions for setting bit 8 have not been met. 1 = A data parity error occurred, and the following conditions were met: a. PERR was asserted by any PCI device including the PCI1221. b. The PCI1221 was the bus master during the data parity error. c. The parity error response bit is set in the command.
7	FBB_CAP	R	Fast back-to-back capable. The PCI1221 cannot accept fast back-to-back transactions; thus, bit 7 is hardwired to 0.
6	UDF	R	User-definable feature support. The PCI1221 does not support the user-definable features; thus, bit 6 is hardwired to 0.
5	66MHZ	R	66-MHz capable. The PCI1221 operates at a maximum PCLK frequency of 33 MHz; therefore, bit 5 is hardwired to 0.
4	CAPLIST	R	Capabilities list. Bit 4 is read only and returns 1 when read. This bit indicates that capabilities in addition to standard PCI capabilities are implemented. The linked list of PCI power-management capabilities is implemented in this function.
3–0	RSVD	R	Reserved. Bits 3–0 return 0s when read.

# PCI1221 GHK/PDV PC CARD CONTROLLERS

SCPS042 – JULY 1998

## revision ID register

Bit	7	6	5	4	3	2	1	0
Name	Revision ID							
Type	R	R	R	R	R	R	R	R
Default	0	0	0	0	0	0	0	0

Register: **Revision ID**  
 Type: Read only  
 Offset: 08h (functions 0, 1)  
 Default: 00h  
 Description: This read-only register indicates the silicon revision of the PCI1221.

## PCI class code register

Bit	23	22	21	20	19	18	17	16	15	14	13	12	11	10	9	8	7	6	5	4	3	2	1	0	
Name	Class code																								
	Base class								Sub class								Programming interface								
Type	R	R	R	R	R	R	R	R	R	R	R	R	R	R	R	R	R	R	R	R	R	R	R	R	R
Default	0	0	0	0	0	1	1	0	0	0	0	0	0	1	1	1	0	0	0	0	0	0	0	0	0

Register: **PCI Class code**  
 Type: Read only  
 Offset: 09h (functions 0, 1)  
 Default: 060700h  
 Description: The class code register recognizes the PCI1221 functions 0 and 1 as a bridge device (06h), and CardBus bridge device (07h) with a 00h programming interface.

## cache line size register

Bit	7	6	5	4	3	2	1	0
Name	Cache line size							
Type	R/W	R/W	R/W	R/W	R/W	R/W	R/W	R/W
Default	0	0	0	0	0	0	0	0

Register: **Cache line size**  
 Type: Read/write  
 Offset: 0Ch (functions 0, 1)  
 Default: 00h  
 Description: The cache line size register is programmed by host software to indicate the system cache line size.



**latency timer register**

<b>Bit</b>	<b>7</b>	<b>6</b>	<b>5</b>	<b>4</b>	<b>3</b>	<b>2</b>	<b>1</b>	<b>0</b>
<b>Name</b>	Latency timer							
<b>Type</b>	R/W	R/W	R/W	R/W	R/W	R/W	R/W	R/W
<b>Default</b>	0	0	0	0	0	0	0	0

Register: **Latency timer**

Type: Read/write

Offset: 0Dh

Default: 00h

Description: The latency timer register specifies the latency timer for the PCI1221 in units of PCI clock cycles. When the PCI1221 is a PCI bus initiator and asserts  $\overline{\text{FRAME}}$ , the latency timer begins counting from zero. If the latency timer expires before the PCI1221 transaction has terminated, the PCI1221 terminates the transaction when its  $\overline{\text{GNT}}$  is deasserted. This register is separate for each of the two PCI1221 functions. This allows platforms to prioritize the two PCI1221 functions' use of the PCI bus.

**header type register**

<b>Bit</b>	<b>7</b>	<b>6</b>	<b>5</b>	<b>4</b>	<b>3</b>	<b>2</b>	<b>1</b>	<b>0</b>
<b>Name</b>	Header type							
<b>Type</b>	R	R	R	R	R	R	R	R
<b>Default</b>	1	0	0	0	0	0	1	0

Register: **Header type**

Type: Read only

Offset: 0Eh (functions 0, 1)

Default: 82h

Description: This read-only register returns 82h when read, indicating that the PCI1221 functions 0 and 1 configuration spaces adhere to the CardBus bridge PCI header. The CardBus bridge PCI header ranges from PCI register 0 to 7Fh, and 80h–FFh is user-definable extension registers.

**BIST register**

<b>Bit</b>	<b>7</b>	<b>6</b>	<b>5</b>	<b>4</b>	<b>3</b>	<b>2</b>	<b>1</b>	<b>0</b>
<b>Name</b>	BIST							
<b>Type</b>	R	R	R	R	R	R	R	R
<b>Default</b>	0	0	0	0	0	0	0	0

Register: **BIST**

Type: Read only

Offset: 0Fh (functions 0, 1)

Default: 00h

Description: Because the PCI1221 does not support a built-in self-test (BIST), this register is read only and returns the value of 00h when read.

# PCI1221 GHK/PDV PC CARD CONTROLLERS

SCPS042 – JULY 1998

## CardBus socket registers/ExCA base-address register

Bit	31	30	29	28	27	26	25	24	23	22	21	20	19	18	17	16
Name	CardBus socket/ExCA base address															
Type	R/W	R/W	R/W	R/W	R/W	R/W	R/W	R/W	R/W	R/W	R/W	R/W	R/W	R/W	R/W	R/W
Default	0	0	0	0	0	0	0	0	0	0	0	0	0	0	0	0
Bit	15	14	13	12	11	10	9	8	7	6	5	4	3	2	1	0
Name	CardBus socket/ExCA base address															
Type	R/W	R/W	R/W	R/W	R	R	R	R	R	R	R	R	R	R	R	R
Default	0	0	0	0	0	0	0	0	0	0	0	0	0	0	0	0

Register: **CardBus socket/ExCA base address**

Type: Read only, read/write

Offset: 10h

Default: 0000 0000h

Description: The CardBus socket registers/ExCA base-address register is programmed with a base address referencing the CardBus socket registers and the memory-mapped ExCA register set. Bits 31-12 are read/write, and allow the base address to be located anywhere in the 32-bit PCI memory address space on a 4K-byte boundary. Bits 11-0 are read only, returning 0s when read. When software writes all 1s to this register, the value readback is FFFF F000h, indicating that at least 4K-bytes of memory address space are required. The CardBus registers start at offset 000h, and the memory-mapped ExCA registers begin at offset 800h. Since this register is not shared by functions 0 and 1, mapping of each socket control is performed separately.

## capability pointer register

Bit	7	6	5	4	3	2	1	0
Name	Capability pointer							
Type	R	R	R	R	R	R	R	R
Default	1	0	1	0	0	0	0	0

Register: **Capability pointer**

Type: Read only

Offset: 14h

Default: A0h

Description: The capability pointer register provides a pointer into the PCI configuration header where the PCI power management register block resides. PCI header doublewords at A0h and A4h provide the power management (PM) registers. Each socket has its own capability pointer register. This register is read only and returns A0h when read.

# PCI1221 GHK/PDV PC CARD CONTROLLERS

SCPS042 – JULY 1998

## secondary status register

Bit	15	14	13	12	11	10	9	8	7	6	5	4	3	2	1	0
Name	Secondary status															
Type	R/C	R/C	R/C	R/C	R/C	R	R	R/C	R	R	R	R	R	R	R	R
Default	0	0	0	0	0	0	1	0	0	0	0	0	0	0	0	0

Register: **Secondary status**

Type: Read only, read/clear (see individual bit descriptions)

Offset: 16h

Default: 0200h

Description: The secondary status register is compatible with the PCI-to-PCI bridge secondary status register, and indicates CardBus-related device information to the host system. This register is very similar to the PCI status register (offset 06h); status bits are cleared by writing a 1.

**Table 18. Secondary Status Register**

BIT	SIGNAL	TYPE	FUNCTION
15	CBPARITY	R/C	Detected parity error. Bit 15 is set when a CardBus parity error is detected (either address or data).
14	CBSERR	R/C	Signaled system error. Bit 14 is set when CSERR is signaled by a CardBus card. The PCI1221 does not assert CSERR.
13	CBMABORT	R/C	Received master abort. Bit 13 is set when a cycle initiated by the PCI1221 on the CardBus bus has been terminated by a master abort.
12	REC_CBTA	R/C	Received target abort. Bit 12 is set when a cycle initiated by the PCI1221 on the CardBus bus is terminated by a target abort.
11	SIG_CBTA	R/C	Signaled target abort. Bit 11 is set by the PCI1221 when it terminates a transaction on the CardBus bus with a target abort.
10–9	CB_SPEED	R	CDEVSEL timing. These read-only bits encode the timing of CDEVSEL and are hardwired 01b, indicating that the PCI1221 asserts CB_SPEED at a medium speed.
8	CB_DPAR	R/C	CardBus data parity error detected. 0 = The conditions for setting bit 8 have not been met. 1 = A data parity error occurred and the following conditions were met: a. CPERR was asserted on the CardBus interface. b. The PCI1221 was the bus master during the data parity error. c. The parity error response bit is set in the bridge control.
7	CBFBB_CAP	R	Fast back-to-back capable. The PCI1221 cannot accept fast back-to-back transactions; thus, bit 7 is hardwired to 0.
6	CB_UDF	R	User-definable feature support. The PCI1221 does not support the user-definable features; thus, bit 6 is hardwired to 0.
5	CB66MHZ	R	66-MHz capable. The PCI1221 CardBus interface operates at a maximum CCLK frequency of 33 MHz; therefore, bit 5 is hardwired to 0.
4–0	RSVD	R	Reserved. Bits 4–0 return 0s when read.

# PCI1221 GHK/PDV PC CARD CONTROLLERS

SCPS042 – JULY 1998

## PCI bus number register

Bit	7	6	5	4	3	2	1	0
Name	PCI bus number							
Type	R/W	R/W	R/W	R/W	R/W	R/W	R/W	R/W
Default	0	0	0	0	0	0	0	0

Register: **PCI bus number**  
 Type: Read/write  
 Offset: 18h (functions 0, 1)  
 Default: 00h  
 Description: This read/write register is programmed by the host system to indicate the bus number of the PCI bus to which the PCI1221 is connected. The PCI1221 uses this register in conjunction with the CardBus bus number and subordinate bus number registers to determine when to forward PCI configuration cycles to its secondary buses.

## CardBus bus number register

Bit	7	6	5	4	3	2	1	0
Name	CardBus bus number							
Type	R/W	R/W	R/W	R/W	R/W	R/W	R/W	R/W
Default	0	0	0	0	0	0	0	0

Register: **CardBus bus number**  
 Type: Read/write  
 Offset: 19h  
 Default: 00h  
 Description: This read/write register is programmed by the host system to indicate the bus number of the CardBus bus to which the PCI1221 is connected. The PCI1221 uses this register in conjunction with the PCI bus number and subordinate bus number registers to determine when to forward PCI configuration cycles to its secondary buses. This register is separate for each PCI1221 controller function.

## subordinate bus number register

Bit	7	6	5	4	3	2	1	0
Name	Subordinate bus number							
Type	R/W	R/W	R/W	R/W	R/W	R/W	R/W	R/W
Default	0	0	0	0	0	0	0	0

Register: **Subordinate bus number**  
 Type: Read/write  
 Offset: 1Ah  
 Default: 00h  
 Description: This read/write register is programmed by the host system to indicate the highest-numbered bus below the CardBus bus. The PCI1221 uses this register in conjunction with the PCI bus number and CardBus bus number registers to determine when to forward PCI configuration cycles to its secondary buses. This register is separate for each CardBus controller function.

# PCI1221 GHK/PDV PC CARD CONTROLLERS

SCPS042 – JULY 1998

## CardBus latency timer register

Bit	7	6	5	4	3	2	1	0
Name	CardBus latency timer							
Type	R/W	R/W	R/W	R/W	R/W	R/W	R/W	R/W
Default	0	0	0	0	0	0	0	0

Register: **CardBus latency timer**

Type: Read/write

Offset: 1Bh (functions 0, 1)

Default: 00h

Description: This read/write register is programmed by the host system to specify the latency timer for the PCI1221 CardBus interface in units of CCLK cycles. When the PCI1221 is a CardBus initiator and asserts CFAME, the CardBus latency timer begins counting. If the latency timer expires before the PCI1221 transaction has terminated, then the PCI1221 terminates the transaction at the end of the next data phase. A recommended minimum value for this register is 20h, which allows most transactions to be completed.

## memory base registers 0, 1

Bit	31	30	29	28	27	26	25	24	23	22	21	20	19	18	17	16
Name	Memory base registers 0, 1															
Type	R/W	R/W	R/W	R/W	R/W	R/W	R/W	R/W	R/W	R/W	R/W	R/W	R/W	R/W	R/W	R/W
Default	0	0	0	0	0	0	0	0	0	0	0	0	0	0	0	0
Bit	15	14	13	12	11	10	9	8	7	6	5	4	3	2	1	0
Name	Memory base registers 0, 1															
Type	R/W	R/W	R/W	R/W	R	R	R	R	R	R	R	R	R	R	R	R
Default	0	0	0	0	0	0	0	0	0	0	0	0	0	0	0	0

Register: **Memory base registers 0, 1**

Type: Read only, read/write

Offset: 1Ch, 24h

Default: 0000 0000h

Description: The Memory base registers indicate the lower address of a PCI memory address range. These registers are used by the PCI1221 to determine when to forward a memory transaction to the CardBus bus and when to forward a CardBus cycle to PCI. Bits 31-12 of these registers are read/write and allow the memory base to be located anywhere in the 32-bit PCI memory space on 4K-byte boundaries. Bits 11-0 are read only and always return 0s. Write transactions to these bits have no effect. Bits 8 and 9 of the bridge control register specify whether memory windows 0 and 1 are prefetchable or nonprefetchable. The memory base register or the memory limit register must be nonzero for the PCI1221 to claim any memory transactions through CardBus memory windows (i.e., these windows are not enabled by default to pass the first 4K-bytes of memory to CardBus).

# PCI1221 GHK/PDV PC CARD CONTROLLERS

SCPS042 – JULY 1998

## memory limit registers 0, 1

Bit	31	30	29	28	27	26	25	24	23	22	21	20	19	18	17	16
Name	Memory limit registers 0, 1															
Type	R/W	R/W	R/W	R/W	R/W	R/W	R/W	R/W	R/W	R/W	R/W	R/W	R/W	R/W	R/W	R/W
Default	0	0	0	0	0	0	0	0	0	0	0	0	0	0	0	0
Bit	15	14	13	12	11	10	9	8	7	6	5	4	3	2	1	0
Name	Memory limit registers 0, 1															
Type	R/W	R/W	R/W	R/W	R	R	R	R	R	R	R	R	R	R	R	R
Default	0	0	0	0	0	0	0	0	0	0	0	0	0	0	0	0

Register: **Memory limit registers 0, 1**

Type: Read only, read/write

Offset: 20h, 28h

Default: 0000 0000h

Description: The Memory limit registers indicate the upper address of a PCI memory address range. These registers are used by the PCI1221 to determine when to forward a memory transaction to the CardBus bus and when to forward a CardBus cycle to PCI. Bits 31-12 of these registers are read/write and allow the memory base to be located anywhere in the 32-bit PCI memory space on 4K-byte boundaries. Bits 11-0 are read only and always return 0s. Write transactions to these bits have no effect. Bits 8 and 9 of the bridge control register specify whether memory windows 0 and 1 are prefetchable or nonprefetchable. The memory base register or the memory limit register must be nonzero for the PCI1221 to claim any memory transactions through CardBus memory windows (i.e., these windows are not enabled by default to pass the first 4K-bytes of memory to CardBus).

## I/O base registers 0, 1

Bit	31	30	29	28	27	26	25	24	23	22	21	20	19	18	17	16
Name	I/O base registers 0, 1															
Type	R/W	R/W	R/W	R/W	R/W	R/W	R/W	R/W	R/W	R/W	R/W	R/W	R/W	R/W	R/W	R/W
Default	0	0	0	0	0	0	0	0	0	0	0	0	0	0	0	0
Bit	15	14	13	12	11	10	9	8	7	6	5	4	3	2	1	0
Name	I/O base registers 0, 1															
Type	R/W	R/W	R/W	R/W	R/W	R/W	R/W	R/W	R/W	R/W	R/W	R/W	R/W	R/W	R	R
Default	0	0	0	0	0	0	0	0	0	0	0	0	0	0	0	0

Register: **I/O base registers 0, 1**

Type: Read only, read/write

Offset: 2Ch, 34h

Default: 0000 0000h

Description: The I/O base registers indicate the lower address of a PCI I/O address range. These registers are used by the PCI1221 to determine when to forward an I/O transaction to the CardBus bus and when to forward a CardBus cycle to the PCI bus. The lower 16 bits of this register locate the bottom of the I/O window within a 64K byte page, and the upper sixteen bits (31-16) are a page register which locates this 64K byte page in 32-bit PCI I/O address space. Bits 31-2 are read/write. Bits 1-0 are read only and always return 0's, forcing I/O windows to be aligned on a natural doubleword boundary.

### NOTE:

Either the I/O base or the I/O limit register must be nonzero to enable any I/O transactions.

# PCI1221 GHK/PDV PC CARD CONTROLLERS

SCPS042 – JULY 1998

## I/O limit registers 0, 1

<b>Bit</b>	31	30	29	28	27	26	25	24	23	22	21	20	19	18	17	16
<b>Name</b>	I/O limit registers 0, 1															
<b>Type</b>	R	R	R	R	R	R	R	R	R	R	R	R	R	R	R	R
<b>Default</b>	0	0	0	0	0	0	0	0	0	0	0	0	0	0	0	0
<b>Bit</b>	15	14	13	12	11	10	9	8	7	6	5	4	3	2	1	0
<b>Name</b>	I/O limit registers 0, 1															
<b>Type</b>	R/W	R/W	R/W	R/W	R/W	R/W	R/W	R/W	R/W	R/W	R/W	R/W	R/W	R/W	R	R
<b>Default</b>	0	0	0	0	0	0	0	0	0	0	0	0	0	0	0	0

Register: **I/O limit registers 0, 1**

Type: Read only, read/write

Offset: 30h, 38h

Default: 0000 0000h

Description: The I/O limit registers indicate the upper address of a PCI I/O address range. These registers are used by the PCI1221 to determine when to forward an I/O transaction to the CardBus bus and when to forward a CardBus cycle to PCI. The lower 16 bits of this register locate the top of the I/O window within a 64K-byte page, and the upper 16 bits are a page register that locates this 64K-byte page in 32-bit PCI I/O address space. Bits 15-2 are read/write and allow the I/O limit address to be located anywhere in the 64K-byte page (indicated by bits 31-16 of the appropriate I/O base) on doubleword boundaries.

Bits 31-16 are read only and always return 0s when read. The page is set in the I/O base register. Bits 1-0 are read only and always return 0s, forcing I/O windows to be aligned on a natural doubleword boundary. Write transactions to read-only bits have no effect. The PCI1221 assumes that the lower two bits of the limit address are 1s.

**NOTE:**

The I/O base or the I/O limit register must be nonzero to enable an I/O transaction.

## interrupt line register

<b>Bit</b>	7	6	5	4	3	2	1	0
<b>Name</b>	Interrupt line							
<b>Type</b>	R/W	R/W	R/W	R/W	R/W	R/W	R/W	R/W
<b>Default</b>	1	1	1	1	1	1	1	1

Register: **Interrupt line**

Type: Read/write

Offset: 3Ch

Default: FFh

Description: The interrupt line register is read/write and is used to communicate interrupt line routing information. Each PCI1221 function has an interrupt line register.

# PCI1221 GHK/PDV PC CARD CONTROLLERS

SCPS042 – JULY 1998

## interrupt pin register

Bit	7	6	5	4	3	2	1	0
Name	Interrupt pin							
Type	R	R	R	R	R	R	R	R
Default	0	0	0	0	0	0	1	1

Register: **Interrupt pin**  
 Type: Read only  
 Offset: 3Dh  
 Default: Depends on the interrupt signaling mode (sample shown is 03h)  
 Description: The value read from the interrupt pin register is function dependent and depends on the interrupt signaling mode, selected through the device control register and the state of the INTRTIE bit in the system control register. When the INTRTIE bit is set, this register reads 0x01 ( $\overline{\text{INTA}}$ ) for both functions. See Table 19 for the complete description of the register contents.

**Table 19. Interrupt Pin Register Cross Reference**

INTERRUPT SIGNALING MODE	INTRTIE BIT	INTPIN FUNCTION 0	INTPIN FUNCTION 1
Parallel PCI interrupts only	0	0x01 ( $\overline{\text{INTA}}$ )	0x02 ( $\overline{\text{INTB}}$ )
Parallel IRQ and parallel PCI interrupts	0	0x01 ( $\overline{\text{INTA}}$ )	0x02 ( $\overline{\text{INTB}}$ )
IRQ serialized (IRQSER) and parallel PCI interrupts	0	0x01 ( $\overline{\text{INTA}}$ )	0x02 ( $\overline{\text{INTB}}$ )
IRQ and PCI serialized (IRQSER) interrupts (default)	0	0x01 ( $\overline{\text{INTA}}$ )	0x02 ( $\overline{\text{INTB}}$ )
Parallel PCI interrupts only	1	0x01 ( $\overline{\text{INTA}}$ )	0x01 ( $\overline{\text{INTA}}$ )
Parallel IRQ and parallel PCI interrupts	1	0x01 ( $\overline{\text{INTA}}$ )	0x01 ( $\overline{\text{INTA}}$ )
IRQ serialized (IRQSER) and parallel PCI interrupts†	1	0x01 ( $\overline{\text{INTA}}$ )	0x01 ( $\overline{\text{INTA}}$ )
IRQ and PCI serialized (IRQSER) interrupts†	1	0x01 ( $\overline{\text{INTA}}$ )	0x01 ( $\overline{\text{INTA}}$ )

† When configuring the PCI1221 functions to share PCI interrupts, multifunction terminal MFUNC3 must be configured as IRQSER prior to setting the INTRTIE bit.



# PCI1221 GHK/PDV PC CARD CONTROLLERS

SCPS042 – JULY 1998

## bridge control register

Bit	15	14	13	12	11	10	9	8	7	6	5	4	3	2	1	0
Name	Bridge control															
Type	R	R	R	R	R	R/W	R/W	R/W	R/W	R/W	R/W	R	R/W	R/W	R/W	R
Default	0	0	0	0	0	0	1	1	0	1	0	0	0	0	0	0

Register: **Bridge control**

Type: Read only, read/write (see individual bit descriptions)

Offset: 3Eh (functions 0, 1)

Default: 0340h

Description: The bridge control register provides control over various PCI1221 bridging functions. Some bits in this register are global and should be accessed only through function 0. See Table 20 for a complete description of the register contents.

**Table 20. Bridge Control Register**

BIT	SIGNAL	TYPE	FUNCTION
15–11	RSVD	R	Reserved. Bits 15–11 return 0s when read.
10	POSTEN	R/W	Write posting enable. Enables write posting to and from the CardBus sockets. Write posting enables posting of write data on burst cycles. Operating with write posting disabled inhibits performance on burst cycles. Note that bursted write data can be posted, but various write transactions may not. Bit 10 is socket dependent and is not shared between functions 0 and 1.
9	PREFETCH1	R/W	Memory window 1 type. Bit 9 specifies whether or not memory window 1 is prefetchable. This bit is socket dependent. Bit 9 is encoded as: 0 = Memory window 1 is nonprefetchable. 1 = Memory window 1 is prefetchable (default).
8	PREFETCH0	R/W	Memory window 0 type. Bit 8 specifies whether or not memory window 0 is prefetchable. This bit is encoded as: 0 = Memory window 0 is nonprefetchable. 1 = Memory window 0 is prefetchable (default).
7	INTR	R/W	PCI interrupt – IREQ routing enable. Bit 7 is used to select whether PC Card functional interrupts are routed to PCI interrupts or the IRQ specified in the ExCA registers. 0 = Functional interrupts routed to PCI interrupts (default) 1 = Functional interrupts routed by ExCAs
6	CRST	R/W	CardBus reset. When bit 6 is set, $\overline{\text{CRST}}$ is asserted on the CardBus interface. $\overline{\text{CRST}}$ can also be asserted by passing a $\overline{\text{PRST}}$ assertion to CardBus. 0 = $\overline{\text{CRST}}$ deasserted 1 = $\overline{\text{CRST}}$ asserted (default)
5†	MABTMODE	R/W	Master abort mode. Bit 5 controls how the PCI1221 responds to a master abort when the PCI1221 is an initiator on the CardBus interface. This bit is common between each socket. 0 = Master aborts not reported (default) 1 = Signal target abort on PCI and $\overline{\text{SERR}}$ (if enabled)
4	RSVD	R	Reserved. Bit 4 returns 0 when read.
3	VGAEN	R/W	VGA enable. Bit 3 affects how the PCI1221 responds to VGA addresses. When this bit is set, accesses to VGA addresses are forwarded.
2	ISAEN	R/W	ISA mode enable. Bit 2 affects how the PCI1221 passes I/O cycles within the 64K-byte ISA range. This bit is not common between sockets. When this bit is set, the PCI1221 does not forward the last 768 bytes of each 1K I/O range to CardBus.
1†	CSERREN	R/W	$\overline{\text{CSERR}}$ enable. Bit 1 controls the response of the PCI1221 to $\overline{\text{CSERR}}$ signals on the CardBus bus. This bit is common between the two sockets. 0 = $\overline{\text{CSERR}}$ is not forwarded to PCI $\overline{\text{SERR}}$ . 1 = $\overline{\text{CSERR}}$ is forwarded to PCI $\overline{\text{SERR}}$ .
0†	CPERREN	R	CardBus parity error response enable. Bit 0 controls the response of the PCI1221 to CardBus parity errors. This bit is common between the two sockets. 0 = CardBus parity errors are ignored. 1 = CardBus parity errors are reported using $\overline{\text{CPERR}}$ .

† These bits are global and should be accessed only through function 0.

# PCI1221 GHK/PDV PC CARD CONTROLLERS

SCPS042 – JULY 1998

## subsystem vendor ID register

Bit	15	14	13	12	11	10	9	8	7	6	5	4	3	2	1	0
Name	Subsystem vendor ID															
Type	R	R	R	R	R	R	R	R	R	R	R	R	R	R	R	R
Default	0	0	0	0	0	0	0	0	0	0	0	0	0	0	0	0

Register: **Subsystem vendor ID**  
 Type: Read only (read/write when bit 5 in the system control register is 0)  
 Offset: 40h (functions 0, 1)  
 Default: 0000h  
 Description: The subsystem vendor ID register is used for system and option-card identification purposes and may be required for certain operating systems. This register is read only or read/write, depending on the setting of bit 5 (SUBSYSRW) in the system control register. When bit 5 is 0, this register is read/write; when bit 5 is 1, this register is read only. The default mode is read only.

## subsystem ID register

Bit	15	14	13	12	11	10	9	8	7	6	5	4	3	2	1	0
Name	Subsystem ID															
Type	R	R	R	R	R	R	R	R	R	R	R	R	R	R	R	R
Default	0	0	0	0	0	0	0	0	0	0	0	0	0	0	0	0

Register: **Subsystem ID**  
 Type: Read only (read/write when bit 5 in the system control register is 0)  
 Offset: 42h (functions 0, 1)  
 Default: 0000h  
 Description: The subsystem ID register is used for system and option-card identification purposes and may be required for certain operating systems. This register is read only or read/write, depending on the setting of bit 5 (SUBSYSRW) in the system control register. When bit 5 is 0, this register is read/write; when bit 5 is 1, this register is read only. The default mode is read only.

**PC Card 16-bit I/F legacy-mode base address register**

<b>Bit</b>	31	30	29	28	27	26	25	24	23	22	21	20	19	18	17	16
<b>Name</b>	PC Card 16-bit I/F legacy-mode base address															
<b>Type</b>	R/W	R/W	R/W	R/W	R/W	R/W	R/W	R/W	R/W	R/W	R/W	R/W	R/W	R/W	R/W	R/W
<b>Default</b>	0	0	0	0	0	0	0	0	0	0	0	0	0	0	0	0
<b>Bit</b>	15	14	13	12	11	10	9	8	7	6	5	4	3	2	1	0
<b>Name</b>	PC Card 16-bit I/F legacy-mode base address															
<b>Type</b>	R/W	R/W	R/W	R/W	R/W	R/W	R/W	R/W	R/W	R/W	R/W	R/W	R/W	R/W	R/W	R
<b>Default</b>	0	0	0	0	0	0	0	0	0	0	0	0	0	0	0	1

Register: **PC Card 16-bit I/F legacy-mode base address**

Type: Read only, read/write (see individual bit descriptions)

Offset: 44h (functions 0, 1)

Default: 0000 0001h

Description: The PCI1221 supports the index/data scheme of accessing the ExCA registers, which is mapped by this register. An address written to this register is the address for the index register and the address + 1 is the data address. Using this access method, applications requiring index/data ExCA access can be supported. The base address can be mapped anywhere in 32-bit I/O space on a word boundary; hence, bit 0 is read only, returning 1 when read. As specified in the *PCI to PCMCIA CardBus Bridge Register Description* (Yenta), this register is shared by functions 0 and 1. Refer to *ExCA compatibility registers* on page 80 for register offsets.

**system control register**

<b>Bit</b>	31	30	29	28	27	26	25	24	23	22	21	20	19	18	17	16
<b>Name</b>	System control															
<b>Type</b>	R/W	R/W	R/W	R	R/W	R/W	R/W	R/W	R	R/W	R/W	R/W	R	R	R	R
<b>Default</b>	0	0	0	0	0	0	0	0	0	1	0	0	0	0	0	0
<b>Bit</b>	15	14	13	12	11	10	9	8	7	6	5	4	3	2	1	0
<b>Name</b>	System control															
<b>Type</b>	R/W	R/W	R	R	R	R	R	R	R	R/W	R/W	R/W	R	R	R/W	R/W
<b>Default</b>	1	0	0	1	0	0	0	0	0	1	1	0	0	0	0	0

Register: **System control**

Type: Read only, read/write (see individual bit descriptions)

Offset: 80h (functions 0, 1)

Default: 0040 9060h

Description: System-level initializations are performed through programming this doubleword register. Some of the bits are global and should be written only through function 0. See Table 21 for a complete description of the register contents.

# PCI1221 GHK/PDV PC CARD CONTROLLERS

SCPS042 – JULY 1998

**Table 21. System Control Register**

BIT	SIGNAL	TYPE	FUNCTION
31–30†	SER_STEP	R/W	Serialized PCI interrupt routing step. Bits 31–30 are used to configure the serialized PCI interrupt stream signaling, and accomplish an even distribution of interrupts signaled on the four PCI interrupt slots. Bits 31–30 are global to all PCI1221 functions. 00 = INTA/INTB signal in INTA/INTB IRQSER slots 01 = INTA/INTB signal in INTB/INTC IRQSER slots 10 = INTA/INTB signal in INTC/INTD IRQSER slots 11 = INTA/INTB signal in INTD/INTA IRQSER slots
29†	INTRTIE	R/W	Tie internal PCI interrupts. When this bit is set, the INTA and INTB signals are tied together internally and are signaled as INTA. INTA can then be shifted by using the SER_STEP bits. This bit is global to all PCI1221 functions.  When configuring the PCI1221 functions to share PCI interrupts, multifunction terminal MFUNC3 must be configured as IRQSER prior to setting the INTRTIE bit.
28	RSVD	R	Reserved. Bit 28 is read only and returns 0 when read.
27†	P2CLK	R/W	P2C power switch clock. The PCI1221 defaults CLOCK as an input clock to control the serial interface and the internal state machine. Bit 27 can be set to enable the PCI1221 to generate and drive the CLOCK from the PCI clock. When in a SUSPEND state, however, CLOCK must be input to the PCI1221 to successfully power down sockets after card removal without indicating to the system the removal event. 0 = CLOCK provided externally, input to PCI1221 (default) 1 = CLOCK generated by PCI clock and driven by PCI1221
26†	SMIRROUTE	R/W	SMI interrupt routing. Bit 26 is shared between functions 0 and 1, and selects whether IRQ2 or CSC is signaled when a write occurs to power a PC Card socket. 0 = PC Card power change interrupts routed to IRQ2 (default) 1 = A CSC interrupt is generated on PC Card power changes.
25	SMISTATUS	R/W	SMI interrupt status. This socket-dependent bit is set when a write occurs to set the socket power, and the SMIENB bit is set. Writing a 1 to bit 25 clears the status. 0 = SMI interrupt signaled (default) 1 = SMI interrupt not signaled
24†	SMIENB	R/W	SMI interrupt mode enable. When bit 24 is set, the SMI interrupt signaling is enabled and generates an interrupt when a write to the socket power control occurs. This bit is shared and defaults to 0 (disabled).
23	RSVD	R	Reserved. This bit is read only and returns 0 when read.
22	CBRSVD	R/W	CardBus reserved terminals signaling. When bit 22 is set, the RSVD CardBus terminals are driven low when a CardBus card is inserted. When this bit is low (as default), these signals are 3-stated. 0 = 3-state CardBus RSVD 1 = Drive Cardbus RSVD low (default)
21	VCCPROT	R/W	VCC protection enable. Bit 21 is socket dependent. 0 = VCC protection enabled for 16-bit cards (default) 1 = VCC protection disabled for 16-bit cards
20	REDUCEZV	R/W	Reduced Zoom Video Enable. When this bit is enabled, A25–22 of the card interface for PC Card 16 cards is placed in the high impedance state. This bit should not be set for normal ZV operation. This bit is encoded as: 0 = Reduced zoom video disabled (default) 1 = Reduced zoom video enabled
19-16	RSVD	R	Reserved. These bits are reserved and return 0's when read.

† These bits are global and should be accessed only through function 0.

Table 21. System Control Register (Continued)

BIT	SIGNAL	TYPE	FUNCTION
15†	MRBURSTDN	R/W	Memory read burst enable downstream. When bit 15 is set, memory read transactions are allowed to burst downstream. 0 = Downstream memory read burst is disabled. 1 = Downstream memory read burst is enabled (default).
14†	MRBURSTUP	R/W	Memory read burst enable upstream. When bit 14 is set, the PCI1221 allows memory read transactions to burst upstream. 0 = Upstream memory read burst is disabled (default). 1 = Upstream memory read burst is enabled.
13	SOCACTIVE	R	Socket activity status. When set, bit 13 indicates access has been performed to or from a PC card and is cleared upon read of this status bit. This bit is socket dependent. 0 = No socket activity (default) 1 = Socket activity
12	RSVD	R	Reserved. Bit 12 is read only and returns 1 when read.
11†	PWRSTREAM	R	Power stream in progress status bit. When set, bit 11 indicates that a power stream to the power switch is in progress and a powering change has been requested. This bit is cleared when the power stream is complete. 0 = Power stream is complete and delay has expired. 1 = Power stream is in progress.
10†	DELAYUP	R	Power-up delay in progress status. When set, bit 9 indicates that a power-up stream has been sent to the power switch and proper power may not yet be stable. This bit is cleared when the power-up delay has expired.
9†	DELAYDOWN	R	Power-down delay in progress status. When set, bit 10 indicates that a power-down stream has been sent to the power switch and proper power may not yet be stable. This bit is cleared when the power-down delay has expired.
8	INTERROGATE	R	Interrogation in progress. When set, bit 8 indicates an interrogation is in progress and clears when interrogation completes. This bit is socket dependent. 0 = Interrogation not in progress (default) 1 = Interrogation in progress
7	RSVD	R	Reserved. Bit 7 is read only and returns 0 when read.
6	PWRSAVINGS	R/W	Power savings mode enable. When this bit is set, if a CB card is inserted, idle, and without a CB clock, the applicable CB state machine will not be clocked.
5†	SUBSYSRW	R/W	Subsystem ID (SSID), subsystem vendor ID (SSVID), ExCA ID, and revision register read/write enable. Bit 5 is shared by functions 0 and 1. 0 = SSID, SSVID, ExCA ID, and revision register are read/write. 1 = SSID, SSVID, ExCA ID, and revision register are read only (default).
4†	CB_DPAR	R/W	CardBus data parity $\overline{\text{SERR}}$ signaling enable 0 = CardBus data parity not signaled on PCI $\overline{\text{SERR}}$ 1 = CardBus data parity signaled on PCI $\overline{\text{SERR}}$
3-2	RSVD	R	Reserved. This bit is read only and returns 0 when read.
1†	KEEPCLK	R/W	Keep clock. This bit works with PCI and CB $\overline{\text{CLKRUN}}$ protocols. 0 = Allows normal functioning of both $\overline{\text{CLKRUN}}$ protocols.(default) 1 = Does not allow CB clock or PCI clock to be stopped using the $\overline{\text{CLKRUN}}$ protocols.
0	RIMUX	R/W	RI_OUT/PME multiplex enable. 0 = RI_OUT and PME are both routed to the RI_OUT/PME terminal. If both are enabled at the same time, RI_OUT has precedence over PME. 1 = Only PME is routed to the RI_OUT/PME terminal.

† These bits are global and should be accessed only through function 0.

# PCI1221 GHK/PDV PC CARD CONTROLLERS

SCPS042 – JULY 1998

## multifunction routing register

Bit	31	30	29	28	27	26	25	24	23	22	21	20	19	18	17	16
Name	Multifunction routing															
Type	R	R	R	R	R/W	R/W	R/W	R/W	R/W	R/W	R/W	R/W	R/W	R/W	R/W	R/W
Default	0	0	0	0	0	0	0	0	0	0	0	0	0	0	0	0
Bit	15	14	13	12	11	10	9	8	7	6	5	4	3	2	1	0
Name	Multifunction routing															
Type	R/W	R/W	R/W	R/W	R/W	R/W	R/W	R/W	R/W	R/W	R/W	R/W	R/W	R/W	R/W	R/W
Default	0	0	0	0	0	0	0	0	0	0	0	0	0	0	0	0

Register: **Multifunction routing**

Type: Read/only, read/write (see individual bit descriptions)

Offset: 8Ch (functions 0, 1)

Default: 0000 0000h

Description: The Multifunction routing register is used to configure the MFUNC0:6 terminals. These terminals may be configured for various functions. All multifunction terminals default to the general-purpose input configuration. Pullup resistors are required for terminals configured as outputs. This register is intended to be programmed once at power-on initialization. The default value for this register may also be loaded through a serial bus EEPROM.

**Table 22. Multifunction Routing Register**

BIT	SIGNAL	TYPE	FUNCTION
31–28	RSVD	R	Bits 31–28 are read/only and return 0s when read.
27–24	MFUNC6	R/W	Multifunction terminal 6 configuration. These bits control the internal signal mapped to the MFUNC6 terminal as follows: 0000 – RSVD = Reserved input – high impedance (default) 0001 – CLKRUN = PCI clock control signal 0010 – IRQ2 = Parallel ISA type IRQ2 0011 – IRQ3 = Parallel ISA type IRQ3 0100 – IRQ4 = Parallel ISA type IRQ4 0101 – IRQ5 = Parallel ISA type IRQ5 0110 – IRQ6 = Parallel ISA type IRQ6 0111 – IRQ7 = Parallel ISA type IRQ7 1000 – IRQ8 = Parallel ISA type IRQ8 1001 – IRQ9 = Parallel ISA type IRQ9 1010 – IRQ10 = Parallel ISA type IRQ10 1011 – IRQ11 = Parallel ISA type IRQ11 1100 – IRQ12 = Parallel ISA type IRQ12 1101 – IRQ13 = Parallel ISA type IRQ13 1110 – IRQ14 = Parallel ISA type IRQ14 1111 – IRQ15 = Parallel ISA type IRQ15

**Table 22. Multifunction Routing Register (Continued)**

BIT	SIGNAL	TYPE	FUNCTION
23–20	MFUNC5	R/W	<p>Multifunction terminal 5 configuration. These bits control the internal signal mapped to the MFUNC5 terminal as follows:</p> <ul style="list-style-type: none"> <li>0000 – GPI4 = General-purpose input (default)</li> <li>0001 – GPO4 = General-purpose output</li> <li>0010 – RSVD</li> <li>0011 – IRQ3 = Parallel ISA type IRQ3</li> <li>0100 – IRQ4 = Parallel ISA type IRQ4</li> <li>0101 – IRQ5 = Parallel ISA type IRQ5</li> <li>0110 – ZVSTAT = Zoom video status output</li> <li>0111 – ZVSEL1 = Zoom video function 1 select output</li> <li>1000 – CAUDPWM = PWM output of CAUDIO CardBus terminal</li> <li>1001 – IRQ9 = Parallel ISA type IRQ9</li> <li>1010 – IRQ10 = Parallel ISA type IRQ10</li> <li>1011 – IRQ11 = Parallel ISA type IRQ11</li> <li>1100 – LEDA1 = Socket 0 activity LED</li> <li>1101 – LED_SKT = Socket 0 or socket 1 activity LED</li> <li>1110 – GPE = General-Purpose event signal</li> <li>1111 – IRQ15 = Parallel ISA type IRQ15</li> </ul>
19–16	MFUNC4	R/W	<p>Multifunction terminal 4 configuration. These bits control the internal signal mapped to the MFUNC4 terminal as follows:</p> <p>NOTE: When the serial bus mode is implemented by pulling down the LATCH terminal, the MFUNC4 terminal provides the SCL signaling.</p> <ul style="list-style-type: none"> <li>0000 – GPI3 = General-purpose input (default)</li> <li>0001 – GPO3 = General-purpose output</li> <li>0010 – LOCK PCI = Atomic transfer support mechanism</li> <li>0011 – IRQ3 = Parallel ISA type IRQ3</li> <li>0100 – IRQ4 = Parallel ISA type IRQ4</li> <li>0101 – IRQ5 = Parallel ISA type IRQ5</li> <li>0110 – ZVSTAT = Zoom video status output</li> <li>0111 – ZVSEL1 = Zoom video function 1 select output</li> <li>1000 – CAUDPWM = PWM output of CAUDIO CardBus terminal</li> <li>1001 – IRQ9 = Parallel ISA type IRQ9</li> <li>1010 – IRQ10 = Parallel ISA type IRQ10</li> <li>1011 – IRQ11 = Parallel ISA type IRQ11</li> <li>1100 – RI_OUT = Ring-indicate output</li> <li>1101 – LED_SKT = Socket 0 or socket 1 activity LED</li> <li>1110 – GPE = General-purpose event signal</li> <li>1111 – IRQ15 = Parallel ISA type IRQ15</li> </ul>
15–12	MFUNC3	R/W	<p>Multifunction terminal 3 configuration. These bits control the internal signal mapped to the MFUNC3 terminal as follows:</p> <ul style="list-style-type: none"> <li>0000 – RSVD = Reserved input – high impedance</li> <li>0001 – IRQSER = Serial interrupt stream, IRQ and optional PCI (default)</li> <li>0010 – IRQ2 = Parallel ISA type IRQ2</li> <li>0011 – IRQ3 = Parallel ISA type IRQ3</li> <li>0100 – IRQ4 = Parallel ISA type IRQ4</li> <li>0101 – IRQ5 = Parallel ISA type IRQ5</li> <li>0110 – IRQ6 = Parallel ISA type IRQ6</li> <li>0111 – IRQ7 = Parallel ISA type IRQ7</li> <li>1000 – IRQ8 = Parallel ISA type IRQ8</li> <li>1001 – IRQ9 = Parallel ISA type IRQ9</li> <li>1010 – IRQ10 = Parallel ISA type IRQ10</li> <li>1011 – IRQ11 = Parallel ISA type IRQ11</li> <li>1100 – IRQ12 = Parallel ISA type IRQ12</li> <li>1101 – IRQ13 = Parallel ISA type IRQ13</li> <li>1110 – IRQ14 = Parallel ISA type IRQ14</li> <li>1111 – IRQ15 = Parallel ISA type IRQ15</li> </ul>

# PCI1221 GHK/PDV PC CARD CONTROLLERS

SCPS042 – JULY 1998

**Table 22. Multifunction Routing Register (Continued)**

BIT	SIGNAL	TYPE	FUNCTION
11–8	MFUNC2	R/W	<p>Multifunction terminal 2 configuration. These bits control the internal signal mapped to the MFUNC2 terminal as follows:</p> <ul style="list-style-type: none"> <li>0000 – GPI2 = General-purpose input (default)</li> <li>0001 – GPO2 = General-purpose output</li> <li>0010 – RSVD</li> <li>0011 – IRQ3 = Parallel ISA type IRQ3</li> <li>0100 – IRQ4 = Parallel ISA type IRQ4</li> <li>0101 – IRQ5 = Parallel ISA type IRQ5</li> <li>0110 – ZVSTAT = Zoom video status output</li> <li>0111 – ZVSEL0 = Zoom video function 0 select output</li> <li>1000 – CAUDPWM = PWM output of CAUDIO CardBus terminal</li> <li>1001 – IRQ9 = Parallel ISA type IRQ9</li> <li>1010 – IRQ10 = Parallel ISA type IRQ10</li> <li>1011 – IRQ11 = Parallel ISA type IRQ11</li> <li>1100 – RI_OUT = Ring-indicate output</li> <li>1101 – LEDA2 = Socket 1 activity LED</li> <li>1110 – GPE = General-purpose event signal</li> <li>1111 – IRQ7 = Parallel ISA type IRQ7</li> </ul>
7–4	MFUNC1	R/W	<p>Multifunction terminal 1 configuration. These bits control the internal signal mapped to the MFUNC1 terminal as follows:</p> <p>NOTE: When the serial bus mode is implemented by pulling down the LATCH terminal, the MFUNC1 terminal provides the SDA signaling.</p> <ul style="list-style-type: none"> <li>0000 – GPI1 = General-purpose input (default)</li> <li>0001 – GPO1 = General-purpose output</li> <li>0010 – INTB = PCI interrupt signal, INTB</li> <li>0011 – IRQ3 = Parallel ISA type IRQ3</li> <li>0100 – IRQ4 = Parallel ISA type IRQ4</li> <li>0101 – IRQ5 = Parallel ISA type IRQ5</li> <li>0110 – ZVSTAT = Zoom video status output</li> <li>0111 – ZVSEL0 = Zoom video function 0 select output</li> <li>1000 – CAUDPWM = PWM output of CAUDIO CardBus terminal</li> <li>1001 – IRQ9 = Parallel ISA type IRQ9</li> <li>1010 – IRQ10 = Parallel ISA type IRQ10</li> <li>1011 – IRQ11 = Parallel ISA type IRQ11</li> <li>1100 – LEDA1 = Socket 0 activity LED</li> <li>1101 – LEDA2 = Socket 1 activity LED</li> <li>1110 – GPE = General-purpose event signal</li> <li>1111 – IRQ15 = Parallel ISA type IRQ15</li> </ul>
3–0	MFUNC0	R/W	<p>Multifunction terminal 0 configuration. These bits control the internal signal mapped to the MFUNC0 terminal as follows:</p> <ul style="list-style-type: none"> <li>0000 – GPI0 = General-purpose input (default)</li> <li>0001 – GPO0 = General-purpose output</li> <li>0010 – INTA = PCI interrupt signal, INTA</li> <li>0011 – IRQ3 = Parallel ISA type IRQ3</li> <li>0100 – IRQ4 = Parallel ISA type IRQ4</li> <li>0101 – IRQ5 = Parallel ISA type IRQ5</li> <li>0110 – ZVSTAT = Zoom video status output</li> <li>0111 – ZVSEL0 = Zoom video function 0 select output</li> <li>1000 – CAUDPWM = PWM output of CAUDIO CardBus terminal</li> <li>1001 – IRQ9 = Parallel ISA type IRQ9</li> <li>1010 – IRQ10 = Parallel ISA type IRQ10</li> <li>1011 – IRQ11 = Parallel ISA type IRQ11</li> <li>1100 – LEDA1 = Socket 0 activity LED</li> <li>1101 – LEDA2 = Socket 1 activity LED</li> <li>1110 – GPE = General-purpose event signal</li> <li>1111 – IRQ15 = Parallel ISA type IRQ15</li> </ul>



retry status register

Bit	7	6	5	4	3	2	1	0
Name	Retry status							
Type	R/W	R/W	R/C	R	R/C	R	R/C	R
Default	1	1	0	0	0	0	0	0

Register: **Retry status**

Type: Read only, read/write, read/clear (see individual bit descriptions)

Offset: 90h (functions 0, 1)

Default: C0h

Description: The retry status register enables the retry timeout counters and displays the retry expiration status. The flags are set when the PCI1221 retries a PCI or CardBus master request, and the master does not return within  $2^{15}$  PCI clock cycles. The flags are cleared by writing a 1 to the bit. These bits are expected to be incorporated into the PCI command, PCI status, and bridge control registers by the PCI SIG. Access this register only through function 0. See Table 23 for a complete description of the register contents.

**Table 23. Retry Status Register**

BIT	SIGNAL	TYPE	FUNCTION
7	PCIRETRY	R/W	PCI retry timeout counter enable. Bit 7 is encoded: 0 = PCI retry counter disabled 1 = PCI retry counter enabled (default)
6†	CBRETRY	R/W	CardBus retry timeout counter enable. Bit 6 is encoded: 0 = CardBus retry counter disabled 1 = CardBus retry counter enabled (default)
5	TEXP_CBB	R/C	CardBus target B retry expired. Write a 1 to clear bit 5. 0 = Inactive (default) 1 = Retry has expired
4	RSVD	R	Reserved. Bit 4 returns 0 when read.
3†	TEXP_CBA	R/C	CardBus target A retry expired. Write a 1 to clear bit 3. 0 = Inactive (default) 1 = Retry has expired.
2	RSVD	R	Reserved. Bit 2 returns 0 when read.
1	TEXP_PCI	R/C	PCI target retry expired. Write a 1 to clear bit 1. 0 = Inactive (default) 1 = Retry has expired.
0	RSVD	R	Reserved. Bit 0 returns 0 when read.

† These bits are global and should be accessed only through function 0.

# PCI1221 GHK/PDV PC CARD CONTROLLERS

SCPS042 – JULY 1998

## card control register

Bit	7	6	5	4	3	2	1	0
Name	Card control							
Type	R/W	R/W	R/W	R	R	R/W	R/W	R/C
Default	0	0	0	0	0	0	0	0

Register: **Card control**  
 Type: Read only, read/write, read/clear (see individual bit descriptions)  
 Offset: 91h  
 Default: 00h  
 Description: The card control register is provided for PCI1130 compatibility. RI\_OUT is enabled through this register, and the enable bit is shared between functions 0 and 1. See Table 24 for a complete description of the register contents.

**Table 24. Card Control Register**

BIT	SIGNAL	TYPE	FUNCTION
7†	RIENB	R/W	Ring indicate output enable. 0 = Disables any routing of RI_OUT signal (default). 1 = Enables RI_OUT signal for routing to the RI_OUT/PME terminal when RIMUX is set to 0, and for routing to MFUNC2/4.
6	ZVENABLE	R/W	Compatibility ZV mode enable. When set, the corresponding PC Card Socket interface ZV terminals enter a high-impedance state. This bit defaults to 0.
5	PORT_SEL	R/W	Port Select. This bit controls the priority for the <u>ZVSEL0</u> and <u>ZVSEL1</u> signaling if ZVENABLE is set in both functions. 0 = Socket 0 takes priority, as signaled through <u>ZVSEL0</u> , when both sockets are in ZV mode. 1 = Socket 1 takes priority, as signaled through <u>ZVSEL1</u> , when both sockets are in ZV mode.
4–3	RSVD	R	Reserved. Bits 4–3 are read only and default to 0.
2	AUD2MUX	R/W	CardBus Audio-to-IRQMUX. When set, the CAUDIO CardBus signal is routed to the corresponding multifunction terminal which may be configured for CAUDPWM. When both socket 0 and 1 functions have AUD2MUX set, socket 0 takes precedence.
1	SPKROUTEN	R/W	Speaker out enable. When bit 1 is set, <u>SPKR</u> on the PC Card is enabled and is routed to SPKROUT. The <u>SPKR</u> signal from socket 0 is exclusive ORed with the <u>SPKR</u> signal from socket 1 and sent to SPKROUT. The SPKROUT terminal drives data only when either functions SPKROUTEN bit is set. This bit is encoded as: 0 = <u>SPKR</u> to SPKROUT not enabled 1 = <u>SPKR</u> to SPKROUT enabled
0	IFG	R/C	Interrupt flag. Bit 0 is the interrupt flag for 16-bit I/O PC Cards and for CardBus cards. Bit 0 is set when a functional interrupt is signaled from a PC Card interface and is socket dependent (i.e., not global). Write back a 1 to clear this bit. 0 = No PC Card functional interrupt detected (default). 1 = PC Card functional interrupt detected.

† This bit is global and should be accessed only through function 0.

# PCI1221 GHK/PDV PC CARD CONTROLLERS

SCPS042 – JULY 1998

## device control register

Bit	7	6	5	4	3	2	1	0
Name	Device control							
Type	R	R/W	R/W	R	R/W	R/W	R/W	R
Default	0	1	1	0	0	1	1	0

Register: **Device control**

Type: Read only, read/write (see individual bit descriptions)

Offset: 92h (functions 0, 1)

Default: 66h

Description: The device control register is provided for PCI1130 compatibility and contains bits that are shared between functions 0 and 1. The interrupt mode select is programmed through this register which is composed of PCI1221 global bits. The socket-capable force bits are also programmed through this register. See Table 25 for a complete description of the register contents.

**Table 25. Device Control Register**

BIT	SIGNAL	TYPE	FUNCTION
7	RSVD	R	Reserved. Bit 7 Returns 0 when read.
6†	3VCAPABLE	R/W	3-V socket capable force 0 = Not 3-V capable 1 = 3-V capable (default)
5	IO16R2	R/W	Diagnostic bit. This bit defaults to 1.
4	RSVD	R	Reserved. Bit 4 returns 0 when read. Write transactions have no effect.
3†	TEST	R/W	Tl test. Only a 0 should be written to bit 3.
2-1	INTMODE	R/W	Interrupt mode. Bit 2-1 select the interrupt signaling mode. The interrupt mode bits are encoded: 00 = Parallel PCI interrupts only 01 = Parallel IRQ and parallel PCI interrupts 10 = IRQ serialized interrupts and parallel PCI interrupt 11 = IRQ and PCI serialized interrupts (default)
0†	RSVD	R/W	Reserved. This read/write bit is reserved for test purposes. Only 0 should be written to this bit.

† These bits are global and should be accessed only through function 0.

# PCI1221 GHK/PDV PC CARD CONTROLLERS

SCPS042 – JULY 1998

## diagnostic register

Bit	7	6	5	4	3	2	1	0
Name	Diagnostic							
Type	R/W	R/W	R/W	R/W	R/W	R/W	R/W	R/W
Default	0	1	1	0	0	0	0	1

Register: **Diagnostic**  
 Type: Read/write  
 Offset: 93h (functions 0, 1)  
 Default: 61h  
 Description: The diagnostic register is provided for internal TI test purposes. It is a read/write register, but only 0s should be written to this register. See Table 26 for a complete description of the register contents.

**Table 26. Diagnostic Register**

BIT	SIGNAL	TYPE	FUNCTION
7†	TRUE_VAL	R/W	This bit defaults to 0. This bit is encoded as: 0 = Reads true values in PCI Vendor ID and PCI Device ID registers (default) 1 = Reads all 1's in reads to the PCI Vendor ID and PCI Device ID registers
6-5	RSVD	R/W	Reserved. These bits are reserved for TI internal test purposes. The value of these bits should not be changed for normal operation.
4†	DIAG4	R/W	Diagnostic RETRY_DIS. Delayed transaction disable.
3†	DIAG3	R/W	Diagnostic RETRY_EXT. Extends the latency from 16 to 64.
2†	DIAG2	R/W	Diagnostic DISCARD_TIM_SEL_CB. Set = $2^{10}$ , reset = $2^{15}$ .
1†	DIAG1	R/W	Diagnostic DISCARD_TIM_SEL_PCI. Set = $2^{10}$ , reset = $2^{15}$ .
0	ASYNC	R/W	Asynchronous interrupt enable. 0 = CSC interrupt is not generated asynchronously 1 = CSC interrupt is generated asynchronously (default)

† These bits are global and should be accessed only through function 0.

---

**capability ID register**

Bit	7	6	5	4	3	2	1	0
Name	Capability ID							
Type	R	R	R	R	R	R	R	R
Default	0	0	0	0	0	0	0	1

Register: **Capability ID**

Type: Read only

Offset: A0h

Default: 01h

Description: The capability ID register identifies the linked list item as the register for PCI power management. The register returns 01h when read, which is the unique ID assigned by the PCI SIG for the PCI location of the capabilities pointer and the value.

**next-item pointer register**

Bit	7	6	5	4	3	2	1	0
Name	Next-item pointer							
Type	R	R	R	R	R	R	R	R
Default	0	0	0	0	0	0	0	0

Register: **Next-item pointer**

Type: Read only

Offset: A1h

Default: 00h

Description: The next-item pointer register is used to indicate the next item in the linked list of the PCI power management capabilities. Because the PCI1221 functions include only one capabilities item, this register returns 0s when read.

**power-management capabilities register**

Bit	15	14	13	12	11	10	9	8	7	6	5	4	3	2	1	0
Name	Power-management capabilities															
Type	R	R	R	R	R	R	R	R	R	R	R	R	R	R	R	R
Default	0	1	1	1	1	1	1	0	0	0	1	0	0	0	0	1

Register: **Power-management capabilities**  
 Type: Read only (see individual bit descriptions)  
 Offset: A2h (functions 0, 1)  
 Default: 7E21h  
 Description: The power-management capabilities register contains information on the capabilities of the PC Card function related to power management. Both PCI1221 CardBus bridge functions support D0, D2, and D3 power states. See Table 27 for a complete description of the register contents.

**Table 27. Power-Management Capabilities Register**

BIT	SIGNAL	TYPE	FUNCTION
15–11	PME_CAP	R	PME support. This 5-bit field indicates the power states from which the PCI1221 supports asserting $\overline{\text{PME}}$ . A 0 for any bit indicates that the CardBus function cannot assert $\overline{\text{PME}}$ from that power state. These five bits return 01111b when read. Each of these bits is described below: Bit 15 contains the value 0, indicating that $\overline{\text{PME}}$ cannot be asserted from D3 <sub>cold</sub> state. Bit 14 contains the value 1, indicating that $\overline{\text{PME}}$ can be asserted from D3 <sub>hot</sub> state. Bit 13 contains the value 1, indicating that $\overline{\text{PME}}$ can be asserted from D2 state. Bit 12 contains the value 1, indicating that $\overline{\text{PME}}$ can be asserted from D1 state. Bit 11 contains the value 1, indicating that $\overline{\text{PME}}$ can be asserted from the D0 state.
10	D2_CAP	R	D2 support. Bit 10 returns a 1 when read, indicating that the CardBus function supports the D2 device power state.
9	D1_CAP	R	D1 support. Bit 9 returns a 1 when read, indicating that the CardBus function supports the D1 device power state.
8	DYN_DATA	R	Dynamic data support. Bit 8 returns a 0 when read, indicating that the CardBus function does not report dynamic power consumption data.
7–6	RSVD	R	Reserved. These bits are reserved and return 00b when read.
5	DSI	R	Device-specific initialization. Bit 5 is read only and returns 1 when read, indicating that the CardBus controller functions require special initialization (beyond the standard PCI configuration header) before the generic class device driver is able to use it.
4	AUX_PWR	R	Auxiliary power source. Bit 4 is meaningful only if bit 15 (D3 <sub>cold</sub> supporting $\overline{\text{PME}}$ ) is set. When set, bit 4 indicates that the function supplies its own auxiliary power source.
3	PMECLK	R	$\overline{\text{PME}}$ clock. Bit 3 is read only and returns 0 when read, indicating that no host bus clock is required for the PCI1221 to generate $\overline{\text{PME}}$ .
2–0	VERSION	R	Version. Bits 2–0 return 001b when read, indicating that there are four bytes of general-purpose power management (PM) registers as described in the <i>PCI Bus Power Management Interface Specification</i> , Revision 1.0.

**power-management control/status register**

Bit	15	14	13	12	11	10	9	8	7	6	5	4	3	2	1	0
Name	Power-management control/status															
Type	R/C	R	R	R	R	R	R	R/W	R	R	R	R	R	R	R/W	R/W
Default	0	0	0	0	0	0	0	0	0	0	0	0	0	0	0	0

Register: **Power-management control/status**

Type: Read only, read/write, read/clear (see individual bit descriptions)

Offset: A4h (functions 0, 1)

Default: 0000h

Description: The power-management control/status register determines and changes the current power state of the PCI1221 CardBus function. The contents of this register are not affected by the internally-generated reset caused by the transition from D3<sub>hot</sub> to D0 state. See Table 28 for a complete description of the register contents.

**Table 28. Power-Management Control/Status Register**

BIT	SIGNAL	TYPE	FUNCTION
15	PMESTAT	R/C	PME status. Bit 15 is set when the CardBus function would normally assert $\overline{\text{PME}}$ , independent of the state of the $\overline{\text{PME\_EN}}$ bit. Bit 15 is cleared by a write back of 1, and this also clears the $\overline{\text{PME}}$ signal if $\overline{\text{PME}}$ was asserted by this function. Writing a 0 to this bit has no effect.
14–13	DATASCALE	R	Data scale. This 2-bit field is read only, returning 0s when read. The CardBus function does not return any dynamic data as indicated by the $\overline{\text{DYN\_DATA}}$ bit.
12–9	DATASEL	R	Data select. This 4-bit field is read only and returns 0s when read. The CardBus function does not return any dynamic data as indicated by the $\overline{\text{DYN\_DATA}}$ bit.
8		R/W	PME enable. Bit 8 enables the function to assert $\overline{\text{PME}}$ . If this bit is cleared, assertion of $\overline{\text{PME}}$ is disabled.
7–2	RSVD	R	Reserved. Bits 7–2 are read only and return 0s when read.
1–0	PWR_STATE	R/W	Power state. This 2-bit field is used both to determine the current power state of a function, and to set the function into a new power state. This field is encoded as: 00 = D0 01 = D1 10 = D2 11 = D3 <sub>hot</sub>

**power-management control/status register bridge support extensions**

Bit	7	6	5	4	3	2	1	0
Name	Power-management control/status register bridge support extensions							
Type	R	R	R	R	R	R	R	R
Default	1	0	0	0	0	0	0	0

Register: **Power-management control/status register bridge support extensions**  
 Type: Read only  
 Offset: A6h (functions 0, 1)  
 Default: 00h  
 Description: The power-management control/status register bridge support extensions support PCI bridge specific functionality. See Table 29 for a complete description of the register contents.

**Table 29. Power-Management Control/Status Register Bridge Support Extensions**

BIT	SIGNAL	TYPE	FUNCTION
7	BPCC_EN	R	Bus power/clock control. When read, bit 7 returns 1b.
6	B2_B3	R	B2/B3 support for D3 <sub>hot</sub> . This bit is read only and returns a 0 when read.
5-0	RSVD	R	Reserved. These bits are read only and return 0s when read.

**power management data register**

Bit	7	6	5	4	3	2	1	0
Name	power management data							
Type	R	R	R	R	R	R	R	R
Default	0	0	0	0	0	0	0	0

Register: **Power management data**  
 Type: Read only  
 Offset: A7h (functions 0, 1)  
 Default: 00h  
 Description: The power management data register is read only and returns zeros when read, since the CardBus functions do not report dynamic data.



### general-purpose event status register

Bit	15	14	13	12	11	10	9	8	7	6	5	4	3	2	1	0
Name	Power-management control/status															
Type	R/C	R/C	R	R	R/C	R	R	R/C	R	R	R	R/C	R/C	R/C	R/C	R/C
Default	0	0	0	0	0	0	0	0	0	0	0	0	0	0	0	0

Register: **General-purpose event status**

Type: Read only, read/clear (see individual bit descriptions)

Offset: A8h (function 0)

Default: 0000h

Description: The general-purpose event status register contains status bits that are set when events occur that are controlled by the general-purpose control register. The bits in this register and the corresponding GPE are cleared by writing a 1 to the corresponding bit location. The status bits in this register do not depend upon the state of a corresponding bit in the general-purpose enable register. Access this register only through function 0. See Table 30 for a complete description of the register contents.

**Table 30. General-Purpose Event Status Register**

BIT	SIGNAL	TYPE	FUNCTION
15	ZV0_STS	R/C	PC card socket 0 ZV Status. Bit 15 is set on a change in status of the ZVENABLE bit in the function 0 PC card controller function of the PCI1221.
14	ZV1_STS	R/C	PC card socket 1 ZV Status. Bit 14 is set on a change in status of the ZVENABLE bit in the function 1 PC card controller function of the PCI1221.
13–12	RSVD	R	Reserved. These bits are read only and return zero when read.
11	PWR_STS	R/C	Power change status. Bit 11 is set when software has changed the power state of either socket. A change in either V <sub>CC</sub> or V <sub>PP</sub> for either socket causes this bit to be set.
10–9	RSVD	R	Reserved. These bits are read only and return zero when read.
8	VPP12_STS	R/C	12 Volt V <sub>pp</sub> request status. Bit 8 is set when software has changed the requested V <sub>pp</sub> level to or from 12 Volts for either of the two PC Card sockets.
7–5	RSVD	R	Reserved. These bits are read only and return zero when read.
4	GP4_STS	R/C	GPI4 Status. Bit 4 is set on a change in status of the MFUNC5 terminal input level.
3	GP3_STS	R/C	GPI3 Status. Bit 3 is set on a change in status of the MFUNC4 terminal input level.
2	GP2_STS	R/C	GPI2 Status. Bit 2 is set on a change in status of the MFUNC2 terminal input level.
1	GP1_STS	R/C	GPI1 Status. Bit 1 is set on a change in status of the MFUNC1 terminal input level.
0	GP0_STS	R/C	GPI0 Status. Bit 0 is set on a change in status of the MFUNC0 terminal input level.

### general-purpose event enable register

Bit	15	14	13	12	11	10	9	8	7	6	5	4	3	2	1	0
Name	General-purpose event enable															
Type	R/W	R/W	R	R	R/W	R	R	R/W	R	R	R	R/W	R/W	R/W	R/W	R/W
Default	0	0	0	0	0	0	0	0	0	0	0	0	0	0	0	0

Register: **General-purpose event enable**

Type: Read only, read/write (see individual bit descriptions)

Offset: AAh (function 0)

Default: 0000h

Description: The general-purpose event enable register contains bits that are set to enable a  $\overline{\text{GPE}}$  signal. The  $\overline{\text{GPE}}$  signal is driven until the corresponding status bit is cleared and the event is serviced. The  $\overline{\text{GPE}}$  can only be signaled if one of the multifunction terminals, MFUNC6:0, is configured for  $\overline{\text{GPE}}$  signaling. Access this register only through function 0. See Table 31 for a complete description of the register contents.

**Table 31. General-Purpose Event Enable Register**

BIT	SIGNAL	TYPE	FUNCTION
15	ZV0_EN	R/W	PC card socket 0 ZV enable. When bit 15 is set, a $\overline{\text{GPE}}$ is signaled on a change in status of ZVENABLE in the function 0 PC Card controller function of the PCI1221.
14	ZV1_EN	R/W	PC card socket 1 ZV enable. When bit 14 is set, a $\overline{\text{GPE}}$ is signaled on a change in status of ZVENABLE in the function 1 PC Card controller function of the PCI1221.
13–12	RSVD	R	Reserved. These bits are read only and return zero when read.
11	PWR_EN	R/W	Power change enable. When bit 11 is set, a $\overline{\text{GPE}}$ is signaled on when software has changed the power state of either socket.
10–9	RSVD	R	Reserved. These bits are read only and return zero when read.
8	VPP12_EN	R/W	12 Volt Vpp request enable. When bit 8 is set, a $\overline{\text{GPE}}$ is signaled when software has changed the requested Vpp level to or from 12 Volts for either card socket.
7–5	RSVD	R	Reserved. These bits are read only and return zero when read.
4	GP4_EN	R/W	GPI4 enable. When bit 4 is set, a $\overline{\text{GPE}}$ is signaled when there has been a change in status of the MFUNC5 terminal input level if configured as GPI4.
3	GP3_EN	R/W	GPI3 enable. When bit 3 is set, a $\overline{\text{GPE}}$ is signaled when there has been a change in status of the MFUNC4 terminal input level if configured as GPI3.
2	GP2_EN	R/W	GPI2 enable. When bit 2 is set, a $\overline{\text{GPE}}$ is signaled when there has been a change in status of the MFUNC2 terminal input if configured as GPI2.
1	GP1_EN	R/W	GPI1 enable. When bit 1 is set, a $\overline{\text{GPE}}$ is signaled when there has been a change in status of the MFUNC1 terminal input if configured as GPI1.
0	GP0_EN	R/W	GPI0 enable. When bit 0 is set, a $\overline{\text{GPE}}$ is signaled when there has been a change in status of the MFUNC0 terminal input if configured as GPI0.

### general-purpose input register

Bit	15	14	13	12	11	10	9	8	7	6	5	4	3	2	1	0
Name	General-purpose input															
Type	R	R	R	R	R	R	R	R	R	R	R	R	R	R	R	R
Default	0	0	0	0	0	0	0	0	0	0	0	X	X	X	X	X

Register: **General-purpose input**

Type: Read only (see individual bit descriptions)

Offset: ACh (function 0)

Default: 00XXh

Description: The general-purpose input register provides the logical value of the data input from the GPI terminals, MFUNC5:4 and MFUNC2:0. Access this register only through function 0. See Table 32 for a complete description of the register contents.

**Table 32. General-Purpose Input Register**

BIT	SIGNAL	TYPE	FUNCTION
15-5	RSVD	R	Reserved. Bits 15-5 are read only and return 0 when read. Write transactions have no effect.
4	GPI4_DATA	R	GPI4 Data Bit. The value read from bit 4 represents the logical value of the data input from the MFUNC5 terminal. Write transactions have no effect.
3	GPI3_DATA	R	GPI3 Data Bit. The value read from bit 3 represents the logical value of the data input from the MFUNC4 terminal. Write transactions have no effect.
2	GPI2_DATA	R	GPI2 Data Bit. The value read from bit 2 represents the logical value of the data input from the MFUNC2 terminal. Write transactions have no effect.
1	GPI1_DATA	R	GPI1 Data Bit. The value read from bit 1 represents the logical value of the data input from the MFUNC1 terminal. Write transactions have no effect.
0	GPI0_DATA	R	GPI0 Data Bit. The value read from bit 0 represents the logical value of the data input from the MFUNC0 terminal. Write transactions have no effect.

**general-purpose output register**

Bit	15	14	13	12	11	10	9	8	7	6	5	4	3	2	1	0
Name	General-purpose output															
Type	R	R	R	R	R	R	R	R	R	R	R	R/W	R/W	R/W	R/W	R/W
Default	0	0	0	0	0	0	0	0	0	0	0	0	0	0	0	0

Register: **General-purpose output**

Type: Read only, read/write (see individual bit descriptions)

Offset: AEh (function 0)

Default: 0000h

Description: The general-purpose output register is used for control of the general-purpose outputs. Access this register only through function 0. See Table 33 for a complete description of the register contents.

**Table 33. General-Purpose Output Register**

BIT	SIGNAL	TYPE	FUNCTION
15-5	RSVD	R	Reserved. Bits 15-5 are read only and return 0 when read. Write transactions have no effect.
4	GPO4_DATA	R/W	GPO4 Data Bit. The value written to bit 4 represents the logical value of the data driven to the MFUNC5 terminal if configured as GPO4. Read transactions return the last data value written.
3	GPO3_DATA	R/W	GPO3 Data Bit. The value written to bit 3 represents the logical value of the data driven to the MFUNC4 terminal if configured as GPO3. Read transactions return the last data value written.
2	GPO2_DATA	R/W	GPO2 Data Bit. The value written to bit 2 represents the logical value of the data driven to the MFUNC2 terminal if configured as GPO2. Read transactions return the last data value written.
1	GPO1_DATA	R/W	GPO1 Data Bit. The value written to bit 1 represents the logical value of the data driven to the MFUNC1 terminal if configured as GPO1. Read transactions return the last data value written.
0	GPO0_DATA	R/W	GPO0 Data Bit. The value written to bit 0 represents the logical value of the data driven to the MFUNC0 terminal if configured as GPO0. Read transactions return the last data value written.

---

### serial bus data register

Bit	7	6	5	4	3	2	1	0
Name	Serial bus data							
Type	R/W	R/W	R/W	R/W	R/W	R/W	R/W	R/W
Default	0	0	0	0	0	0	0	0

Register: **Serial bus data**

Type: Read/write

Offset: B0h (function 0)

Default: 00h

Description: The serial bus data register is for programmable serial bus byte reads and writes. This register represents the data when generating cycles on the serial bus interface. To write a byte, this register must be programmed with the data, the serial bus index register must be programmed with the byte address, the serial bus slave address must be programmed with both the 7-bit slave address, and the read/write indicator bit must be reset.

On byte reads, the byte address is programmed into the serial bus index register, the serial bus slave address must be programmed with both the 7-bit slave address and the read/write indicator bit must be set, and the REQBUSY bit in the serial bus control and status register must be polled until clear. Then the contents of this register are valid read data from the serial bus interface. See Table 34 for a complete description of the register contents.

**Table 34. Serial Bus Data Register**

BIT	SIGNAL	TYPE	FUNCTION
7-0	SBDATA	R/W	Serial bus data. This bit field represents the data byte in a read or write transaction on the serial interface. On reads, the REQBUSY bit must be polled to verify that the contents of this register are valid.

### serial bus index register

Bit	7	6	5	4	3	2	1	0
Name	Serial bus index							
Type	R/W	R/W	R/W	R/W	R/W	R/W	R/W	R/W
Default	0	0	0	0	0	0	0	0

Register: **Serial bus index**

Type: Read/write

Offset: B1h (function 0)

Default: 00h

Description: The serial bus index register is for programmable serial bus byte reads and writes. This register represents the byte address when generating cycles on the serial bus interface. To write a byte, the serial bus data register must be programmed with the data, this register must be programmed with the byte address, and the serial bus slave address must be programmed with both the 7-bit slave address and the read/write indicator.

On byte reads, the word address is programmed into this register, the serial bus slave address must be programmed with both the 7-bit slave address and the read/write indicator bit must be set, and the REQBUSY bit in the serial bus control and status register must be polled until clear. Then the contents of the serial bus data register are valid read data from the serial bus interface. See Table 35 for a complete description of the register contents.

**Table 35. Serial Bus Index Register**

BIT	SIGNAL	TYPE	FUNCTION
7-0	SBINDEX	R/W	Serial bus index. This bit field represents the byte address in a read or write transaction on the serial interface.

**serial bus slave address register**

Bit	7	6	5	4	3	2	1	0
Name	Serial bus slave address							
Type	R/W	R/W	R/W	R/W	R/W	R/W	R/W	R/W
Default	0	0	0	0	0	0	0	0

Register: **Serial bus slave address**

Type: Read/write

Offset: B2h (function 0)

Default: 00h

Description: The serial bus slave address register is for programmable serial bus byte read and write transactions. To write a byte, the serial bus data register must be programmed with the data, the serial bus index register must be programmed with the byte address, and this register must be programmed with both the 7-bit slave address and the read/write indicator bit.

On byte reads, the byte address is programmed into the serial bus index register, this register must be programmed with both the 7-bit slave address and the read/write indicator bit must be set, and the REQBUSY bit in the serial bus control and status register must be polled until clear. Then the contents of the serial bus data register are valid read data from the serial bus interface. See Table 36 for a complete description of the register contents.

**Table 36. Serial Bus Slave Address Register**

BIT	SIGNAL	TYPE	FUNCTION
7-1	SLAVADDR	R/W	Serial bus slave address. This bit field represents the slave address of a read or write transaction on the serial interface.
0	RWCMD	R/W	Read/write command. Bit 0 indicates the read/write command bit presented to the serial bus on byte read and write accesses 0 = A byte write access is requested to the serial bus interface 1 = A byte read access is requested to the serial bus interface

### serial bus control and status register

Bit	7	6	5	4	3	2	1	0
Name	Serial bus control and status							
Type	R/W	R	R	R	R/C	R/W	R/C	R/C
Default	0	0	0	0	0	0	0	0

Register: **Serial bus control and status**

Type: Read only, read/write, read/clear (see individual bit descriptions)

Offset: B3h (function 0)

Default: 00h

Description: The serial bus control and status register is used to communicate serial bus status information and select the quick command protocol. The REQBUSY bit in this register must be polled during serial bus byte reads to indicate when data is valid in the serial bus data register. See Table 37 for a complete description of the register contents.

**Table 37. Serial Bus Control and Status Register**

BIT	SIGNAL	TYPE	FUNCTION
7	PROT_SEL	R/W	Protocol select. When bit 7 is set, the send byte protocol is used on write requests and the receive byte protocol is used on read commands. The word address byte in the serial bus index register is not output by the PC11221 when bit 7 is set.
6	RSVD	R	Reserved. Bit 6 is read only and returns zero when read.
5	REQBUSY	R	Requested serial bus access busy. Bit 5 indicates that a requested serial bus access (byte read or write) is in progress. A request is made, and bit 5 is set, by writing to the serial bus slave address register. Bit 5 must be polled on reads from the serial interface. After the byte read access has been requested, the read data is valid in the serial bus data register.
4	ROMBUSY	R	Serial EEPROM Busy status. Bit 4 indicates the status of the PC11221 serial EEPROM circuitry. Bit 4 is set during the loading of the subsystem ID and other default values from the serial bus EEPROM. 0 = Serial EEPROM circuitry is not busy 1 = Serial EEPROM circuitry is busy
3	SBDETECT	R/C	Serial bus detect. When bit 3 is set, it indicates that the serial bus interface is detected. A pulldown resistor must be implemented on the LATCH terminal for bit 3 to be set. If bit 3 is reset, then the MFUNC4 and MFUNC1 terminals can be used for alternate functions such as general-purpose inputs and outputs. 0 = Serial bus interface not detected 1 = Serial bus interface detected
2	SBTEST	R/W	Serial bus test. When bit 2 is set, the serial bus clock frequency is increased for test purposes. 0 = Serial bus clock at normal operating frequency, $\approx$ 100 kHz (default) 1 = Serial bus clock frequency increased for test purposes
1	REQ_ERR	R/C	Requested serial bus access error. Bit 1 indicates when a data error occurs on the serial interface during a requested cycle and may be set due to a missing acknowledge. Bit 1 is cleared by a write back of 1. 0 = No error detected during user requested byte read or write cycle 1 = Data error detected during user requested byte read or write cycle
0	ROM_ERR	R/C	EEPROM data error status. Bit 0 indicates when a data error occurs on the serial interface during the auto-load from the serial bus EEPROM and may be set due to a missing acknowledge. Bit 0 is also set on invalid EEPROM data formats. Refer to <i>serial bus interface implementation</i> on page 29 for details on EEPROM data format. Bit 0 is cleared by a write back of 1. 0 = No error detected during auto-load from serial bus EEPROM 1 = Data error detected during auto-load from serial bus EEPROM

## ExCA compatibility registers (functions 0 and 1)

The ExCA registers implemented in the PCI1221 are register-compatible with the Intel 82365SL–DF PCMCIA controller. ExCA registers are identified by an offset value that is compatible with the legacy I/O index/data scheme used on the Intel 82365 ISA controller. The ExCA registers are accessed through this scheme by writing the register offset value into the index register (I/O base) and reading or writing the data register (I/O base + 1). The I/O base address used in the index/data scheme is programmed in the PC Card 16-Bit I/F legacy mode base address register, which is shared by both card sockets. The offsets from this base address run contiguous from 00h to 3Fh for socket A, and from 40h to 7Fh for socket B. Refer to Figure 21 for an ExCA I/O mapping illustration.

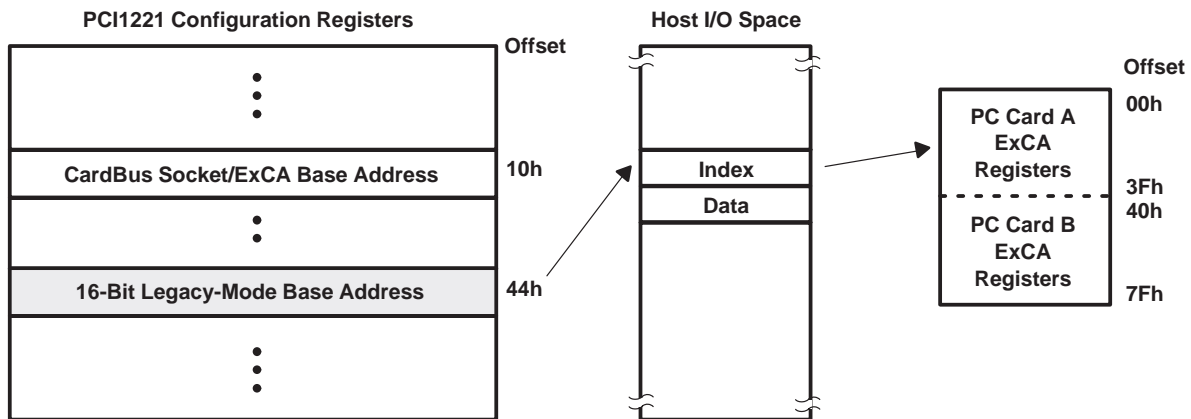

NOTE: The 16-bit legacy mode base address register is shared by functions 0 and 1 as indicated by the shading.

**Figure 21. ExCA Register Access Through I/O**



## ExCA compatibility registers (functions 0 and 1) (continued)

The TI PCI1221 also provides a memory mapped alias of the ExCA registers by directly mapping them into PCI memory space. They are located through the CardBus Socket Registers/ExCA Registers Base Address Register (PCI Register 10h) at memory offset 800h. Each socket has a separate base address programmable by function. Refer to Figure 22 for an ExCA memory mapping illustration. Note that memory offsets are 800h–844h for both functions 0 and 1. This illustration also identifies the CardBus Socket Register mapping, which are mapped into the same 4K-window at memory offset 0h.

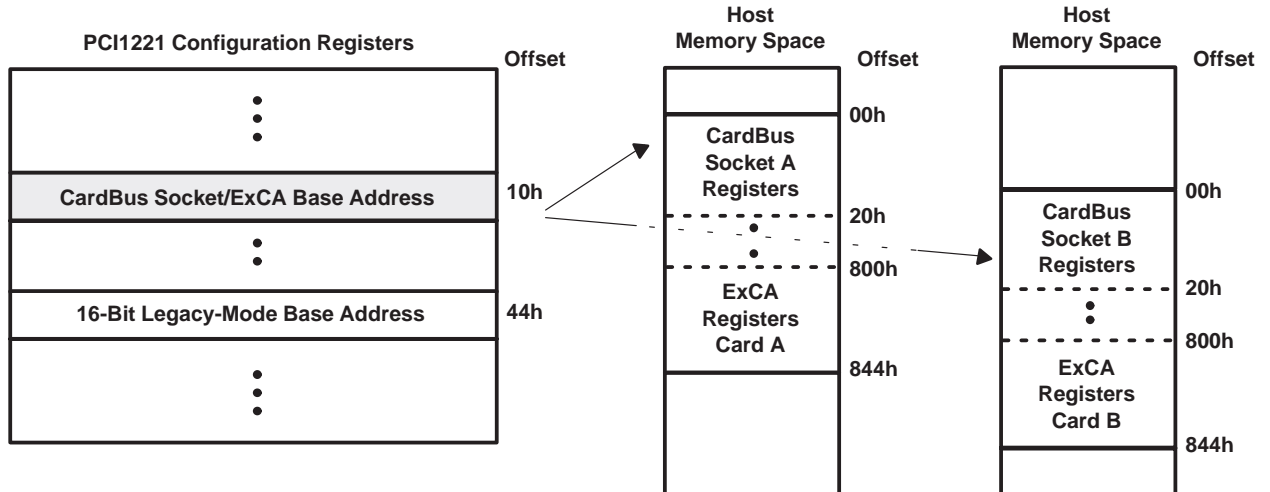

NOTE: The CardBus socket/ExCA base address mode register is separate for functions 0 and 1.

**Figure 22. ExCA Register Access Through Memory**

The interrupt registers, as defined by the 82365SL–DL Specification, in the ExCA register set control such card functions as reset, type, interrupt routing, and interrupt enables. Special attention must be paid to the interrupt routing registers and the host interrupt signaling method selected for the PCI1221 to ensure that all possible PCI1221 interrupts can potentially be routed to the programmable interrupt controller. The ExCA registers that are critical to the interrupt signaling are at memory address ExCA offset 803h and 805h.

Access to I/O mapped 16-bit PC cards is available to the host system via two ExCA I/O windows. These are regions of host I/O address space into which the card I/O space is mapped. These windows are defined by start, end, and offset addresses programmed in the ExCA registers described in this section. I/O windows have byte granularity.

Access to memory mapped 16-bit PC Cards is available to the host system via five ExCA memory windows. These are regions of host memory space into which the card memory space is mapped. These windows are defined by start, end, and offset addresses programmed in the ExCA registers described in this section. (Table 38 identifies each ExCA register and its respective ExCA offset.) Memory windows have 4K-byte granularity.

**Table 38. ExCA Registers and Offsets**

ExCA REGISTER NAME	PCI MEMORY ADDRESS OFFSET (HEX)	ExCA OFFSET (HEX)	
		CARD A	CARD B
Identification and revision	800	00	40
Interface status	801	01	41
Power control	802	02	42
Interrupt and general control	803	03	43
Card status change	804	04	44
Card status-change-interrupt configuration	805	05	45
Address window enable	806	06	46
I / O window control	807	07	47
I / O window 0 start-address low byte	808	08	48
I / O window 0 start-address high byte	809	09	49
I / O window 0 end-address low byte	80A	0A	4A
I / O window 0 end-address high byte	80B	0B	4B
I / O window 1 start-address low byte	80C	0C	4C
I / O window 1 start-address high byte	80D	0D	4D
I / O window 1 end-address low byte	80E	0E	4E
I / O window 1 end-address high byte	80F	0F	4F
Memory window 0 start-address low byte	810	10	50
Memory window 0 start-address high byte	811	11	51
Memory window 0 end-address low byte	812	12	52
Memory window 0 end-address high byte	813	13	53
Memory window 0 offset-address low byte	814	14	54
Memory window 0 offset-address high byte	815	15	55
Card detect and general control	816	16	56
Reserved	817	17	57
Memory window 1 start-address low byte	818	18	58
Memory window 1 start-address high byte	819	19	59
Memory window 1 end-address low byte	81A	1A	5A
Memory window 1 end-address high byte	81B	1B	5B
Memory window 1 offset-address low byte	81C	1C	5C
Memory window 1 offset-address high byte	81D	1D	5D
Global control	81E	1E	5E
Reserved	81F	1F	5F

**Table 38. ExCA Registers and Offsets (Continued)**

ExCA REGISTER NAME	PCI MEMORY ADDRESS OFFSET (HEX)	ExCA OFFSET (HEX)	
		CARD A	CARD B
Memory window 2 start-address low byte	820	20	60
Memory window 2 start-address high byte	821	21	61
Memory window 2 end-address low byte	822	22	62
Memory window 2 end-address high byte	823	23	63
Memory window 2 offset-address low byte	824	24	64
Memory window 2 offset-address high byte	825	25	65
Reserved	826	26	66
Reserved	827	27	67
Memory window 3 start-address low byte	828	28	68
Memory window 3 start-address high byte	829	29	69
Memory window 3 end-address low byte	82A	2A	6A
Memory window 3 end-address high byte	82B	2B	6B
Memory window 3 offset-address low byte	82C	2C	6C
Memory window 3 offset-address high byte	82D	2D	6D
Reserved	82E	2E	6E
Reserved	82F	2F	6F
Memory window 4 start-address low byte	830	30	70
Memory window 4 start-address high byte	831	31	71
Memory window 4 end-address low byte	832	32	72
Memory window 4 end-address high byte	833	33	73
Memory window 4 offset-address low byte	834	34	74
Memory window 4 offset-address high byte	835	35	75
I/O window 0 offset-address low byte	836	36	76
I/O window 0 offset-address high byte	837	37	77
I/O window 1 offset-address low byte	838	38	78
I/O window 1 offset-address high byte	839	39	79
Reserved	83A	3A	7A
Reserved	83B	3B	7B
Reserved	83C	3C	7C
Reserved	83D	3D	7D
Reserved	83E	3E	7E
Reserved	83F	3F	7F
Memory window page 0	840	–	–
Memory window page 1	841	–	–
Memory window page 2	842	–	–
Memory window page 3	843	–	–
Memory window page 4	844	–	–

---

**ExCA identification and revision register (index 00h)**

<b>Bit</b>	<b>7</b>	<b>6</b>	<b>5</b>	<b>4</b>	<b>3</b>	<b>2</b>	<b>1</b>	<b>0</b>
<b>Name</b>	ExCA identification and revision							
<b>Type</b>	R	R	R/W	R/W	R/W	R/W	R/W	R/W
<b>Default</b>	1	0	0	0	0	1	0	0

Register: **ExCA identification and revision**

Type: Read only, read/write (see individual bit descriptions)

Offset: CardBus socket address + 800h; Card A ExCA offset 00h  
Card B ExCA offset 40h

Default: 84h

Description: This register provides host software with information on 16-bit PC Card support and Intel 82365SL-DF compatibility. See Table 39 for a complete description of the register contents.

**Table 39. ExCA Identification and Revision Register (Index 00h)**

<b>BIT</b>	<b>SIGNAL</b>	<b>TYPE</b>	<b>FUNCTION</b>
7-6	IFTYPE	R	Interface type. These read-only bits, which are hardwired as 10b, identify the 16-bit PC Card support provided by the PCI1221. The PCI1221 supports both I/O and memory 16-bit PC cards.
5-4	RSVD	R/W	Reserved. Bits 5-4 can be used for Intel 82365SL-DF emulation.
3-0	365REV	R/W	Intel 82365SL-DF revision. This read/write field stores the Intel 82365SL-DF revision supported by the PCI1221. Host software can read this field to determine compatibility to the Intel 82365SL-DF register set. This field defaults to 0100b upon PCI1221 reset.

### ExCA interface status register (index 01h)

Bit	7	6	5	4	3	2	1	0
Name	ExCA interface status							
Type	R	R	R	R	R	R	R	R
Default	0	0	X	X	X	X	X	X

Register: **ExCA interface status**

Type: Read only (see individual bit descriptions)

Offset: CardBus socket address + 801h; Card A ExCA offset 01h

Card B ExCA offset 41h

Default: 00XX XXXXb

Description: This register provides information on the current status of the PC Card interface. An X in the default bit value indicates that the value of the bit after reset depends on the state of the PC Card interface. See Table 40 for a complete description of the register contents.

**Table 40. ExCA Interface Status Register (Index 01h)**

BIT	SIGNAL	TYPE	FUNCTION
7	RSVD	R	Reserved. Bit 7 is read only and returns 0 when read. Write transactions have no effect.
6	CARDPWR	R	Card Power. Bit 6 indicates the current power status of the PC Card socket. This bit reflects how the power control register is programmed. Bit 6 is encoded as: 0 = V <sub>CC</sub> and V <sub>PP</sub> to the socket turned off (default) 1 = V <sub>CC</sub> and V <sub>PP</sub> to the socket turned on
5	READY	R	Ready. Bit 5 indicates the current status of the READY signal at the PC Card interface. 0 = PC Card not ready for data transfer 1 = PC Card ready for data transfer
4	CARDWP	R	Card write protect. Bit 4 indicates the current status of WP at the PC Card interface. This signal reports to the PCI1221 whether or not the memory card is write protected. Furthermore, write protection for an entire PCI1221 16-bit memory window is available by setting the appropriate bit in the memory window offset high-byte register. 0 = WP is 0. PC Card is R/W. 1 = WP is 1. PC Card is read only.
3	CDETECT2	R	Card detect 2. Bit 3 indicates the status of CD2 at the PC Card interface. Software may use this and CDETECT1 to determine if a PC Card is fully seated in the socket. 0 = CD2 is 1. No PC Card is inserted. 1 = CD2 is 0. PC Card is at least partially inserted.
2	CDETECT1	R	Card detect 1. Bit 2 indicates the status of CD1 at the PC Card interface. Software may use this and CDETECT2 to determine if a PC Card is fully seated in the socket. 0 = CD1 is 1. No PC Card is inserted. 1 = CD1 is 0. PC Card is at least partially inserted.
1-0	BVDSTAT	R	Battery voltage detect. When a 16-bit memory card is inserted, the field indicates the status of the battery voltage detect signals (BVD1, BVD2) at the PC Card interface, where bit 1 reflects the BVD2 status and bit 0 reflects BVD1. 00 = Battery dead 01 = Battery dead 10 = Battery low; warning 11 = Battery good  When a 16-bit I/O card is inserted, this field indicates the status of $\overline{\text{SPKR}}$ (bit 1) and STSCHG (bit 0) at the PC Card interface. In this case, the two bits in this field directly reflect the current state of these card outputs.

**ExCA power-control register (index 02h)**

Bit	7	6	5	4	3	2	1	0
Name	ExCA power control							
Type	R/W	R	R	R/W	R/W	R	R/W	R/W
Default	0	0	0	0	0	0	0	0

Register: **ExCA power control**

Type: Read only, read/write (see individual bit descriptions)

Offset: CardBus socket address + 802h; Card A ExCA offset 02h  
Card B ExCA offset 42h

Default: 00h

Description: This register provides PC Card power control. Bit 7 of this register controls the 16-bit outputs on the socket interface, and can be used for power management in 16-bit PC Card applications. See Table 41 for a complete description of the register contents.

**Table 41. ExCA Power-Control Register (Index 02h)**

BITS	SIGNAL	TYPE	FUNCTION
7	COE	R/W	Card output enable. Bit 7 controls the state of all of the 16-bit outputs on the PCI1221. This bit is encoded as: 0 = 16-bit PC Card outputs disabled (default) 1 = 16-bit PC Card outputs enabled
6-5	RSVD	R	Reserved. Bits 6–5 are read only and return 0s when read. Write transactions have no effect.
4-3	EXCAVCC	R/W	V <sub>CC</sub> . Bits 4-3 are used to request changes to card V <sub>CC</sub> . This field is encoded as: 00 = 0 V (default) 01 = 0 V reserved 10 = 5 V 11 = 3 V
2	RSVD	R	Reserved. Bit 2 is read only and returns 0 when read. Write transactions have no effect.
1-0	EXCAVPP	R/W	V <sub>pp</sub> . Bits 1-0 are used to request changes to card V <sub>pp</sub> . The PCI1221 ignores this field unless V <sub>CC</sub> to the socket is enabled (i.e., 5 V or 3.3 V). This field is encoded as: 00 = 0 V (default) 01 = V <sub>CC</sub> 10 = 12 V 11 = 0 V reserved

### ExCA interrupt and general-control register (index 03h)

Bit	7	6	5	4	3	2	1	0
Name	ExCA interrupt and general control							
Type	R/W	R/W	R/W	R/W	R/W	R/W	R/W	R/W
Default	0	0	0	0	0	0	0	0

Register: **ExCA interrupt and general control**

Type: Read/write (see individual bit descriptions)

Offset: CardBus socket address + 803h; Card A ExCA offset 03h  
Card B ExCA offset 43h

Default: 00h

Description: This register controls interrupt routing for I/O interrupts, as well as other critical 16-bit PC Card functions. See Table 42 for a complete description of the register contents.

**Table 42. ExCA Interrupt and General-Control Register (Index 03h)**

BIT	SIGNAL	TYPE	FUNCTION
7	RINGEN	R/W	Card ring indicate enable. Bit 7 enables the ring indicate function of BVD1/RI. This bit is encoded as: 0 = Ring indicate disabled (default) 1 = Ring indicate enabled
6	RESET	R/W	Card reset. Bit 6 controls the 16-bit PC Card RESET, and allows host software to force a card reset. Bit 6 affects 16-bit cards only. This bit is encoded as 0 = RESET signal asserted (default) 1 = RESET signal deasserted
5	CARDTYPE	R/W	Card type. Bit 5 indicates the PC card type. This bit is encoded as: 0 = Memory PC Card installed (default) 1 = I/O PC Card installed
4	CSCROUTE	R/W	PCI Interrupt CSC routing enable bit. When bit 4 is set (high), the card status change interrupts are routed to PCI interrupts. When low, the card status change interrupts are routed using bits 7–4 in the ExCA card status change interrupt configuration register. This bit is encoded as: 0 = CSC interrupts are routed by ExCA registers (default). 1 = CSC interrupts are routed to PCI interrupts.
3-0	INTSELECT	R/W	Card interrupt select for I/O PC Card functional interrupts. Bits 3-0 select the interrupt routing for I/O PC Card functional interrupts. This field is encoded as: 0000 = No interrupt routing (default). 0001 = IRQ1 enabled 0010 = SMI enabled 0011 = IRQ3 enabled 0100 = IRQ4 enabled 0101 = IRQ5 enabled 0110 = IRQ6 enabled 0111 = IRQ7 enabled 1000 = IRQ8 enabled 1001 = IRQ9 enabled 1010 = IRQ10 enabled 1011 = IRQ11 enabled 1100 = IRQ12 enabled 1101 = IRQ13 enabled 1110 = IRQ14 enabled 1111 = IRQ15 enabled

### ExCA card status-change register (index 04h)

Bit	7	6	5	4	3	2	1	0
Name	ExCA card status change							
Type	R	R	R	R	R	R	R	R
Default	0	0	0	0	0	0	0	0

Register: **ExCA card status change**

Type: Read only (see individual bit descriptions)

Offset: CardBus socket address + 804h; Card A ExCA offset 04h  
Card B ExCA offset 44h

Default: 00h

Description: The card status-change register controls interrupt routing for I/O interrupts as well as other critical 16-bit PC Card functions. The register enables these interrupt sources to generate an interrupt to the host. When the interrupt source is disabled, the corresponding bit in this register always reads 0. When an interrupt source is enabled, the corresponding bit in this register is set to indicate that the interrupt source is active. After generating the interrupt to the host, the interrupt service routine must read this register to determine the source of the interrupt. The interrupt service routine is responsible for resetting the bits in this register as well. Resetting a bit is accomplished by one of two methods: a read of this register or an explicit write back of 1 to the status bit. The choice of these two methods is based on the interrupt flag clear mode select, bit 2, in the global control register. See Table 43 for a complete description of the register contents.

**Table 43. ExCA Card Status-Change Register (Index 04h)**

BIT	SIGNAL	TYPE	FUNCTION
7-4	RSVD	R	Reserved. Bits 7-4 are read only and return 0s when read. Write transactions have no effect.
3	CDCHANGE	R	Card detect change. Bit 3 indicates whether a change on CD1 or CD2 occurred at the PC Card interface. This bit is encoded as: 0 = No change detected on either CD1 or CD2 1 = Change detected on either CD1 or CD2
2	READYCHANGE	R	Ready change. When a 16-bit memory is installed in the socket, bit 2 includes whether the source of a PCI1221 interrupt was due to a change on READY at the PC Card interface, indicating that the PC Card is now ready to accept new data. This bit is encoded as: 0 = No low-to-high transition detected on READY (default) 1 = Detected low-to-high transition on READY  When a 16-bit I/O card is installed, bit 2 is always 0.
1	BATWARN	R	Battery warning change. When a 16-bit memory card is installed in the socket, bit 1 indicates whether the source of a PCI1221 interrupt was due to a battery-low warning condition. This bit is encoded as: 0 = No battery warning condition (default) 1 = Detected battery warning condition  When a 16-bit I/O card is installed, bit 1 is always 0.
0	BATDEAD	R	Battery dead or status change. When a 16-bit memory card is installed in the socket, bit 0 indicates whether the source of a PCI1221 interrupt was due to a battery dead condition. This bit is encoded as: 0 = STSCHG deasserted (default) 1 = STSCHG asserted  Ring indicate. When the PCI1221 is configured for ring indicate operation, bit 0 indicates the status of RI.



**ExCA card status-change-interrupt configuration register (index 05h)**

Bit	7	6	5	4	3	2	1	0
Name	ExCA status-change-interrupt configuration							
Type	R/W	R/W	R/W	R/W	R/W	R/W	R/W	R/W
Default	0	0	0	0	0	0	0	0

Register: **ExCA card status-change-interrupt configuration**

Type: Read/write (see individual bit descriptions)

Offset: CardBus socket address + 805h; Card A ExCA offset 05h  
Card B ExCA offset 45h

Default: 00h

Description: This register controls interrupt routing for card status-change interrupts, as well as masking CSC interrupt sources. See Table 44 for a complete description of the register contents.

**Table 44. ExCA Card Status-Change-Interrupt Configuration Register (Index 05h)**

BIT	SIGNAL	TYPE	FUNCTION
7-4	CSCSELECT	R/W	Interrupt select for card status change. Bits 7-4 select the interrupt routing for card status change interrupts. This field is encoded as: 0000 = No interrupt routing (default) 0001 = IRQ1 enabled 0010 = SMI enabled 0011 = IRQ3 enabled 0100 = IRQ4 enabled 0101 = IRQ5 enabled 0110 = IRQ6 enabled 0111 = IRQ7 enabled 1000 = IRQ8 enabled 1001 = IRQ9 enabled 1010 = IRQ10 enabled 1011 = IRQ11 enabled 1100 = IRQ12 enabled 1101 = IRQ13 enabled 1110 = IRQ14 enabled 1111 = IRQ15 enabled
3	CDEN	R/W	Card detect enable. Bit 3 enables interrupts on CD1 or CD2 changes. This bit is encoded as: 0 = Disables interrupts on CD1 or CD2 line changes (default) 1 = Enables interrupts on CD1 or CD2 line changes
2	READYEN	R/W	Ready enable. Bit 2 enables/disables a low-to-high transition on PC Card READY to generate a host interrupt. This interrupt source is considered a card status change. This bit is encoded as: 0 = Disables host interrupt generation (default) 1 = Enables host interrupt generation
1	BATWARNEN	R/W	Battery Warning Enable. Bit 1 enables/disables a battery warning condition to generate a CSC interrupt. This bit is encoded as: 0 = Disables host interrupt generation (default) 1 = Enables host interrupt generation
0	BATDEADEN	R/W	Battery dead enable. Bit 0 enables/disables a battery dead condition on a memory PC Card or assertion of the STSCHG I/O PC Card signal to generate a CSC interrupt. 0 = Disables host interrupt generation (default) 1 = Enables host interrupt generation

### ExCA address window enable register (index 06h)

Bit	7	6	5	4	3	2	1	0
Name	ExCA address window enable							
Type	R/W	R/W	R	R/W	R/W	R/W	R/W	R/W
Default	0	0	0	0	0	0	0	0

Register: **ExCA address window enable**

Type: Read only, read/write (see individual bit descriptions)

Offset: CardBus socket address + 806h; Card A ExCA offset 06h

Card B ExCA offset 46h

Default: 00h

Description: This register enables/disables the memory and I/O windows to the 16-bit PC Card. By default, all windows to the card are disabled. The PCI1221 does not acknowledge PCI memory or I/O cycles to the card if the corresponding enable bit in this register is 0, regardless of the programming of the memory or I/O window start/end/offset address registers. See Table 45 for a complete description of the register contents.

**Table 45. ExCA Address Window Enable Register (Index 06h)**

BIT	SIGNAL	TYPE	FUNCTION
7	IOWIN1EN	R/W	I/O window 1 enable. Bit 7 enables/disables I/O window 1 for the PC Card. This bit is encoded as: 0 = I/O window 1 disabled (default) 1 = I/O window 1 enabled
6	IOWIN0EN	R/W	I/O window 0 enable. Bit 6 enables/disables I/O window 0 for the PC Card. This bit is encoded as: 0 = I/O window 0 disabled (default) 1 = I/O window 0 enabled
5	RSVD	R	Reserved. Bit 5 is read only and returns 0 when read. Write transactions have no effect.
4	MEMWIN4EN	R/W	Memory window 4 enable. Bit 4 enables/disables memory window 4 for the PC Card. This bit is encoded as: 0 = Memory window 4 disabled (default) 1 = Memory window 4 enabled
3	MEMWIN3EN	R/W	Memory window 3 enable. Bit 3 enables/disables memory window 3 for the PC Card. This bit is encoded as: 0 = Memory window 3 disabled (default) 1 = Memory window 3 enabled
2	MEMWIN2EN	R/W	Memory window 2 enable. Bit 2 enables/disables memory window 2 for the PC Card. This bit is encoded as: 0 = Memory window 2 disabled (default) 1 = Memory window 2 enabled
1	MEMWIN1EN	R/W	Memory window 1 enable. Bit 1 enables/disables memory window 1 for the PC Card. This bit is encoded as: 0 = Memory window 1 disabled (default) 1 = Memory window 1 enabled
0	MEMWIN0EN	R/W	Memory window 0 enable. Bit 0 enables/disables memory window 0 for the PC Card. This bit is encoded as: 0 = Memory window 0 disabled (default) 1 = Memory window 0 enabled

### ExCA I/O window control register (index 07h)

Bit	7	6	5	4	3	2	1	0
Name	ExCA I/O window control							
Type	R/W	R/W	R/W	R/W	R/W	R/W	R/W	R/W
Default	0	0	0	0	0	0	0	0

Register: **ExCA I/O window control**

Type: Read/write (see individual bit descriptions)

Offset: CardBus socket address + 807h; Card A ExCA offset 07h  
Card B ExCA offset 47h

Default: 00h

Description: This register contains parameters related to I/O window sizing and cycle timing. See Table 46 for a complete description of the register contents.

**Table 46. ExCA I/O Window Control Register (Index 07h)**

BIT	SIGNAL	TYPE	FUNCTION
7	WAITSTATE1	R/W	I/O window 1 wait state. Bit 7 controls the I/O window 1 wait state for 16-bit I/O accesses. Bit 7 has no effect on 8-bit accesses. This wait-state timing emulates the ISA wait state used by the Intel 82365SL-DF. This bit is encoded as: 0 = 16-bit cycles have standard length (default). 1 = 16-bit cycles are extended by one equivalent ISA wait state.
6	ZEROWS1	R/W	I/O window 1 zero wait state. Bit 6 controls the I/O window 1 wait state for 8-bit I/O accesses. Bit 6 has no effect on 16-bit accesses. This wait-state timing emulates the ISA wait state used by the Intel 82365SL-DF. This bit is encoded as: 0 = 8-bit cycles have standard length (default). 1 = 8-bit cycles are reduced to equivalent of three ISA cycles.
5	IOSIS16W1	R/W	I/O window 1 $\overline{\text{IOSIS16}}$ source. Bit 5 controls the I/O window 1 automatic data sizing feature that uses $\overline{\text{IOSIS16}}$ from the PC Card to determine the data width of the I/O data transfer. This bit is encoded as: 0 = Window data width determined by $\overline{\text{DATASIZE1}}$ , bit 4 (default). 1 = Window data width determined by $\overline{\text{IOSIS16}}$ .
4	DATASIZE1	R/W	I/O window 1 data size. Bit 4 controls the I/O window 1 data size. Bit 4 is ignored if the I/O window 1 $\overline{\text{IOSIS16}}$ source bit (bit 5) is set. This bit is encoded as: 0 = Window data width is 8 bits (default). 1 = Window data width is 16 bits.
3	WAITSTATE0	R/W	I/O window 0 wait state. Bit 3 controls the I/O window 0 wait state for 16-bit I/O accesses. Bit 3 has no effect on 8-bit accesses. This wait-state timing emulates the ISA wait state used by the Intel 82365SL-DF. This bit is encoded as: 0 = 16-bit cycles have standard length (default). 1 = 16-bit cycles are extended by one equivalent ISA wait state.
2	ZEROWS0	R/W	I/O window 0 zero wait state. Bit 2 controls the I/O window 0 wait state for 8-bit I/O accesses. Bit 2 has no effect on 16-bit accesses. This wait-state timing emulates the ISA wait state used by the Intel 82365SL-DF. This bit is encoded as: 0 = 8-bit cycles have standard length (default). 1 = 8-bit cycles are reduced to equivalent of three ISA cycles.
1	IOSIS16W0	R/W	I/O window 0 $\overline{\text{IOSIS16}}$ source. Bit 1 controls the I/O window 0 automatic data sizing feature that uses $\overline{\text{IOSIS16}}$ from the PC Card to determine the data width of the I/O data transfer. This bit is encoded as: 0 = Window data width is determined by $\overline{\text{DATASIZE0}}$ , bit 0 (default). 1 = Window data width is determined by $\overline{\text{IOSIS16}}$ .
0	DATASIZE0	R/W	I/O window 0 data size. Bit 0 controls the I/O window 0 data size. Bit 0 is ignored if the I/O window 0 $\overline{\text{IOSIS16}}$ source bit (bit 1) is set. This bit is encoded as: 0 = Window data width is 8 bits (default). 1 = Window data width is 16 bits.

---

**ExCA I/O window 0 and 1 start-address low-byte register (index 08h, 0Ch)**

Bit	7	6	5	4	3	2	1	0
Name	ExCA I/O window 0 and 1 start-address low byte							
Type	R/W	R/W	R/W	R/W	R/W	R/W	R/W	R/W
Default	0	0	0	0	0	0	0	0

Register: **ExCA I/O window 0 start-address low byte**

Offset: CardBus socket address + 808h; Card A ExCA offset 08h  
Card B ExCA offset 48h

Register: **ExCA I/O window 1 start-address low byte**

Offset: CardBus socket address + 80Ch; Card A ExCA offset 0Ch  
Card B ExCA offset 4Ch

Type: Read/write

Default: 00h

Size: One byte

Description: These registers contain the low byte of the 16-bit I/O window start address for I/O windows 0 and 1. The eight bits of these registers correspond to the lower eight bits of the start address.

**ExCA I/O window 0 and 1 start-address high-byte register (index 09h, 0Dh)**

Bit	7	6	5	4	3	2	1	0
Name	ExCA I/O window 0 and 1 start-address high byte							
Type	R/W	R/W	R/W	R/W	R/W	R/W	R/W	R/W
Default	0	0	0	0	0	0	0	0

Register: **ExCA I/O window 0 start-address high byte**

Offset: CardBus socket address + 809h; Card A ExCA offset 09h  
Card B ExCA offset 49h

Register: **ExCA I/O window 1 start-address high byte**

Offset: CardBus socket address + 80Dh; Card A ExCA offset 0Dh  
Card B ExCA offset 4Dh

Type: Read/write

Default: 00h

Size: One byte

Description: These registers contain the high byte of the 16-bit I/O window start address for I/O windows 0 and 1. The eight bits of these registers correspond to the upper eight bits of the end address.

---

**ExCA I/O window 0 and 1 end-address low-byte register (index 0Ah, 0Eh)**

Bit	7	6	5	4	3	2	1	0
Name	ExCA I/O window 0 and 1 end-address low byte							
Type	R/W	R/W	R/W	R/W	R/W	R/W	R/W	R/W
Default	0	0	0	0	0	0	0	0

Register: **ExCA I/O window 0 end-address low byte**

Offset: CardBus socket address + 80Ah; Card A ExCA offset 0Ah  
Card B ExCA offset 4Ah

Register: **ExCA I/O window 1 end-address low byte**

Offset: CardBus socket address + 80Eh; Card A ExCA offset 0Eh  
Card B ExCA offset 4Eh

Type: Read/write

Default: 00h

Size: One byte

Description: These registers contain the low byte of the 16-bit I/O window end address for I/O windows 0 and 1. The eight bits of these registers correspond to the lower eight bits of the end address.

**ExCA I/O window 0 and 1 end-address high-byte register (index 0Bh, 0Fh)**

Bit	7	6	5	4	3	2	1	0
Name	ExCA I/O window 0 and 1 end-address high byte							
Type	R/W	R/W	R/W	R/W	R/W	R/W	R/W	R/W
Default	0	0	0	0	0	0	0	0

Register: **ExCA I/O window 0 end-address high byte**

Offset: CardBus socket address + 80Bh; Card A ExCA offset 0Bh  
Card B ExCA offset 4Bh

Register: **ExCA I/O window 1 end-address high byte**

Offset: CardBus socket address + 80Fh; Card A ExCA offset 0Fh  
Card B ExCA offset 4Fh

Type: Read/write

Default: 00h

Size: One byte

Description: These registers contain the high byte of the 16-bit I/O window end address for I/O windows 0 and 1. The eight bits of these registers correspond to the upper eight bits of the end address.

---

**ExCA memory window 0–4 start-address low-byte register (index 10h, 18h, 20h, 28h, 30h)**

Bit	7	6	5	4	3	2	1	0
Name	ExCA memory window 0–4 start-address low byte							
Type	R/W	R/W	R/W	R/W	R/W	R/W	R/W	R/W
Default	0	0	0	0	0	0	0	0

Register: **ExCA memory window 0 start-address low byte**

Offset: CardBus socket address + 810h; Card A ExCA offset 10h  
Card B ExCA offset 50h

Register: **ExCA memory window 1 start-address low byte**

Offset: CardBus socket address + 818h; Card A ExCA offset 18h  
Card B ExCA offset 58h

Register: **ExCA memory window 2 start-address low byte**

Offset: CardBus socket address + 820h; Card A ExCA offset 20h  
Card B ExCA offset 60h

Register: **ExCA memory window 3 start-address low byte**

Offset: CardBus socket address + 828h; Card A ExCA offset 28h  
Card B ExCA offset 68h

Register: **ExCA memory window 4 start-address low byte**

Offset: CardBus socket address + 830h; Card A ExCA offset 30h  
Card B ExCA offset 70h

Type: Read/write

Default: 00h

Size: One byte

Description: These registers contain the low byte of the 16-bit memory window start address for memory windows 0, 1, 2, 3, and 4. The eight bits of these registers correspond to bits A19–A12 of the start address.

**ExCA memory window 0–4 start-address high-byte register (index 11h, 19h, 21h, 29h, 31h)**

Bit	7	6	5	4	3	2	1	0
Name	ExCA memory window 0–4 start-address high byte							
Type	R/W	R/W	R/W	R/W	R/W	R/W	R/W	R/W
Default	0	0	0	0	0	0	0	0

Register: **ExCA memory window 0 start-address high byte**  
 Offset: CardBus socket address + 811h; Card A ExCA offset 11h  
           Card B ExCA offset 51h

Register: **ExCA memory window 1 start-address high byte**  
 Offset: CardBus socket address + 819h; Card A ExCA offset 19h  
           Card B ExCA offset 59h

Register: **ExCA memory window 2 start-address high byte**  
 Offset: CardBus socket address + 821h; Card A ExCA offset 21h  
           Card B ExCA offset 61h

Register: **ExCA memory window 3 start-address high byte**  
 Offset: CardBus socket address + 829h; Card A ExCA offset 29h  
           Card B ExCA offset 69h

Register: **ExCA memory window 4 start-address high byte**  
 Offset: CardBus socket address + 831h; Card A ExCA offset 31h  
           Card B ExCA offset 71h

Type: Read/write

Default: 00h

Size: One byte

Description: These registers contain the high nibble of the 16-bit memory window start address for memory windows 0, 1, 2, 3, and 4. The lower four bits of these registers correspond to bits A23–A20 of the start address. In addition, the memory window data width and wait states are set in this register. See Table 47 for a complete description of the register contents.

**Table 47. ExCA Memory Window 0–4 Start-Address High-Byte Register (Index 11h, 19h, 21h, 29h, 31h)**

BIT	SIGNAL	TYPE	FUNCTION
7	DATASIZE	R/W	Data size. Bit 7 controls the memory window data width. This bit is encoded as: 0 = Window data width is 8 bits (default). 1 = Window data width is 16 bits.
6	ZEROWAIT	R/W	Zero wait state. Bit 6 controls the memory window wait state for 8- and 16-bit accesses. This wait-state timing emulates the ISA wait state used by the Intel 82365SL-DF. This bit is encoded as: 0 = 8- and 16-bit cycles have standard length (default). 1 = 8-bit cycles are reduced to equivalent of three ISA cycles. 16-bit cycles are reduced to equivalent of two ISA cycles.
5-4	SCRATCH	R/W	Scratch pad bits. Bits 5-4 are read/write and have no effect on memory window operation.
3-0	STAHN	R/W	Start-address high nibble. Bits 3-0 represent the upper address bits A23–A20 of the memory window start address.

**ExCA memory window 0–4 end-address low-byte register (index 12h, 1Ah, 22h, 2Ah, 32h)**

Bit	7	6	5	4	3	2	1	0
Name	ExCA memory window 0–4 end-address low byte							
Type	R/W	R/W	R/W	R/W	R/W	R/W	R/W	R/W
Default	0	0	0	0	0	0	0	0

Register: **ExCA memory window 0 end-address low byte**

Offset: CardBus socket address + 812h; Card A ExCA offset 12h  
Card B ExCA offset 52h

Register: **ExCA memory window 1 end-address low byte**

Offset: CardBus socket address + 81Ah; Card A ExCA offset 1Ah  
Card B ExCA offset 5Ah

Register: **ExCA memory window 2 end-address low byte**

Offset: CardBus socket address + 822h; Card A ExCA offset 22h  
Card B ExCA offset 62h

Register: **ExCA memory window 3 end-address low byte**

Offset: CardBus socket address + 82Ah; Card A ExCA offset 2Ah  
Card B ExCA offset 6Ah

Register: **ExCA memory window 4 end-address low byte**

Offset: CardBus socket address + 832h; Card A ExCA offset 32h  
Card B ExCA offset 72h

Type: Read/write

Default: 00h

Size: One byte

Description: These registers contain the low byte of the 16-bit memory window end address for memory windows 0, 1, 2, 3, and 4. The eight bits of these registers correspond to bits A19-A12 of the end address.



**ExCA memory window 0–4 end-address high-byte register (index 13h, 1Bh, 23h, 2Bh, 33h)**

Bit	7	6	5	4	3	2	1	0
Name	ExCA memory window 0–4 end-address high byte							
Type	R/W	R/W	R	R	R/W	R/W	R/W	R/W
Default	0	0	0	0	0	0	0	0

Register: **ExCA memory window 0 end-address high byte**

Offset: CardBus socket address + 813h; Card A ExCA offset 13h  
Card B ExCA offset 53h

Register: **ExCA memory window 1 end-address high byte**

Offset: CardBus socket address + 81Bh; Card A ExCA offset 1Bh  
Card B ExCA offset 5Bh

Register: **ExCA memory window 2 end-address high byte**

Offset: CardBus socket address + 823h; Card A ExCA offset 23h  
Card B ExCA offset 63h

Register: **ExCA memory window 3 end-address high byte**

Offset: CardBus socket address + 82Bh; Card A ExCA offset 2Bh  
Card B ExCA offset 6Bh

Register: **ExCA memory window 4 end-address high byte**

Offset: CardBus socket address + 833h; Card A ExCA offset 33h  
Card B ExCA offset 73h

Type: Read only, read/write (see individual bit descriptions)

Default: 00h

Size: One byte

Description: These registers contain the high nibble of the 16-bit memory window end address for memory windows 0, 1, 2, 3, and 4. The lower four bits of these registers correspond to bits A23-A20 of the end address. In addition, the memory window wait states are set in this register. See Table 48 for a complete description of the register contents.

**Table 48. ExCA Memory Window 0–4 End-Address High-Byte Register (Index 13h, 1Bh, 23h, 2Bh, 33h)**

BIT	SIGNAL	TYPE	FUNCTION
7-6	MEMWS	R/W	Wait state. Bits 7-6 specify the number of equivalent ISA wait states to be added to 16-bit memory accesses. The number of wait states added is equal to the binary value of these two bits.
5-4	RSVD	R	Reserved. Bits 5-4 are read only and return 0s when read. Write transactions have no effect.
3-0	ENDHN	R/W	End-address high nibble. Bits 3-0 represent the upper address bits A23–A20 of the memory window end address.

**ExCA memory window 0–4 offset-address low-byte register (index 14h, 1Ch, 24h, 2Ch, 34h)**

Bit	7	6	5	4	3	2	1	0
Name	ExCA memory window 0–4 offset-address low byte							
Type	R/W	R/W	R/W	R/W	R/W	R/W	R/W	R/W
Default	0	0	0	0	0	0	0	0

Register: **ExCA memory window 0 offset-address low byte**

Offset: CardBus socket address + 814h; Card A ExCA offset 14h  
Card B ExCA offset 54h

Register: **ExCA memory window 1 offset-address low byte**

Offset: CardBus socket address + 81Ch; Card A ExCA offset 1Ch  
Card B ExCA offset 5Ch

Register: **ExCA memory window 2 offset-address low byte**

Offset: CardBus socket address + 824h; Card A ExCA offset 24h  
Card B ExCA offset 64h

Register: **ExCA memory window 3 offset-address low byte**

Offset: CardBus socket address + 82Ch; Card A ExCA offset 2Ch  
Card B ExCA offset 6Ch

Register: **ExCA memory window 4 offset-address low byte**

Offset: CardBus socket address + 834h; Card A ExCA offset 34h  
Card B ExCA offset 74h

Type: Read/write

Default: 00h

Size: One byte

Description: These registers contain the low byte of the 16-bit memory window offset address for memory windows 0, 1, 2, 3 and 4. The eight bits of these registers correspond to bits A19-A12 of the offset address.

**ExCA memory window 0–4 offset-address high-byte register (index 15h, 1Dh, 25h, 2Dh, 35h)**

Bit	7	6	5	4	3	2	1	0
Name	ExCA memory window 0–4 offset-address high byte							
Type	R/W	R/W	R/W	R/W	R/W	R/W	R/W	R/W
Default	0	0	0	0	0	0	0	0

Register: **ExCA memory window 0 offset-address high byte**  
 Offset: CardBus socket address + 815h; Card A ExCA offset 15h  
           Card B ExCA offset 55h

Register: **ExCA memory window 1 offset-address high byte**  
 Offset: CardBus socket address + 81Dh; Card A ExCA offset 1Dh  
           Card B ExCA offset 5Dh

Register: **ExCA memory window 2 offset-address high byte**  
 Offset: CardBus socket address + 825h; Card A ExCA offset 25h  
           Card B ExCA offset 65h

Register: **ExCA memory window 3 offset-address high byte**  
 Offset: CardBus socket address + 82Dh; Card A ExCA offset 2Dh  
           Card B ExCA offset 6Dh

Register: **ExCA memory window 4 offset-address high byte**  
 Offset: CardBus socket address + 835h; Card A ExCA offset 35h  
           Card B ExCA offset 75h

Type: Read only, read/write (see individual bit descriptions)  
 Default: 00h  
 Size: One byte  
 Description: These registers contain the high six bits of the 16-bit memory window offset address for memory windows 0, 1, 2, 3 and 4. The lower six bits of these registers correspond to bits A25-A20 of the offset address. In addition, the write protection and common/attribute memory configurations are set in this register. See Table 49 for a complete description of the register contents.

**Table 49. ExCA Memory Window 0–4 Offset-Address High-Byte Register (Index 15h, 1Dh, 25h, 2Dh, 35h)**

BIT	SIGNAL	TYPE	FUNCTION
7	WINWP	R/W	Write protect. Bit 7 specifies whether write operations to this memory window are enabled. This bit is encoded as: 0 = Write operations are allowed (default). 1 = Write operations are not allowed.
6	REG	R/W	Bit 6 specifies whether this memory window is mapped to card attribute or common memory. This bit is encoded as: 0 = Memory window is mapped to common memory (default). 1 = Memory window is mapped to attribute memory.
5-0	OFFHB	R/W	Offset-address high byte. Bits 5-0 represent the upper address bits A25-A20 of the memory window offset address.

---

**ExCA I/O window 0 and 1 offset-address low-byte register (index 36h, 38h)**

Bit	7	6	5	4	3	2	1	0
Name	ExCA I/O window 0 and 1 offset-address low byte							
Type	R/W	R/W	R/W	R/W	R/W	R/W	R/W	R
Default	0	0	0	0	0	0	0	0

Register: **ExCA I/O window 0 offset-address low byte**

Offset: CardBus socket address + 836h; Card A ExCA offset 36h  
Card B ExCA offset 76h

Register: **ExCA I/O window 1 offset-address low byte**

Offset: CardBus socket address + 838h; Card A ExCA offset 38h  
Card B ExCA offset 78h

Type: Read/only, read/write

Default: 00h

Size: One byte

Description: These registers contain the low byte of the 16-bit I/O window offset address for I/O windows 0 and 1. The eight bits of these registers correspond to the lower eight bits of the offset address, and bit 0 is always 0.

**ExCA I/O window 0 and 1 offset-address high-byte register (index 37h, 39h)**

Bit	7	6	5	4	3	2	1	0
Name	ExCA I/O window 0 and 1 offset-address high byte							
Type	R/W	R/W	R/W	R/W	R/W	R/W	R/W	R/W
Default	0	0	0	0	0	0	0	0

Register: **ExCA I/O window 0 offset-address high byte**

Offset: CardBus socket address + 837h; Card A ExCA offset 37h  
Card B ExCA offset 77h

Register: **ExCA I/O window 1 offset-address high byte**

Offset: CardBus socket address + 839h; Card A ExCA offset 39h  
Card B ExCA offset 79h

Type: Read/write

Default: 00h

Size: One byte

Description: These registers contain the high byte of the 16-bit I/O window offset address for I/O windows 0 and 1. The eight bits of these registers correspond to the upper eight bits of the offset address.

### ExCA card detect and general-control register (index 16h)

Bit	7	6	5	4	3	2	1	0
Name	ExCA I/O card detect and general control							
Type	R	R	W	R/W	R	R	R/W	R
Default	X	X	0	0	0	0	0	0

Register: **ExCA card detect and general control**

Type: Read only, write only, read/write (see individual bit descriptions)

Offset: CardBus socket address + 816h; Card A ExCA offset 16h

Card B ExCA offset 56h

Default: XX00 0000b

Description: This register controls how the ExCA registers for the socket respond to card removal, as well as reports the status of  $\overline{VS1}$  and  $\overline{VS2}$  at the PC Card interface. See Table 50 for a complete description of the register contents.

**Table 50. ExCA Card Detect and General-Control Register (Index 16h)**

BIT	SIGNAL	TYPE	FUNCTION
7	VS2STAT	R	$\overline{VS2}$ state. Bit 7 reports the current state of $\overline{VS2}$ at the PC Card interface and, therefore, does not have a default value. 0 = $\overline{VS2}$ low 1 = $\overline{VS2}$ high
6	VS1STAT	R	$\overline{VS1}$ state. Bit 6 reports the current state of $\overline{VS1}$ at the PC Card interface and, therefore, does not have a default value. 0 = $\overline{VS1}$ low 1 = $\overline{VS1}$ high
5	SWCSC	W	Software card detect interrupt. If the card detect enable bit in the card status change interrupt configuration register is set, writing a 1 to bit 5 causes a card-detect card-status change interrupt for the associated card socket. If the card detect enable bit is cleared to 0 in the card status change interrupt configuration register, writing a 1 to the software card detect interrupt bit has no effect. Bit 5 is write only. A read operation of this bit always returns 0.
4	CDRESUME	R/W	Card detect resume enable. If bit 4 is set to 1, then once a card detect change has been detected on $\overline{CD1}$ and $\overline{CD2}$ inputs, $\overline{RI\_OUT}$ goes from high to low. $\overline{RI\_OUT}$ remains low until the card status change bit in the card status change register is cleared. If this bit is a 0, then the card detect resume functionality is disabled. 0 = Card detect resume disabled (default) 1 = Card detect resume enabled
3-2	RSVD	R	Reserved. Bits 3-2 are read only and return 0s when read. Write transactions have no effect.
1	REGCONFIG	R/W	Register configuration on card removal. Bit 1 controls how the ExCA registers for the socket react to a card removal event. This bit is encoded as: 0 = No change to ExCA registers on card removal (default) 1 = Reset ExCA registers on card removal
0	RSVD	R	Reserved. Bit 0 is read only and returns 0 when read. Write transactions have no effect.

**ExCA global-control register (index 1Eh)**

Bit	7	6	5	4	3	2	1	0
Name	ExCA global control							
Type	R	R	R	R/W	R/W	R/W	R/W	R/W
Default	0	0	0	0	0	0	0	0

Register: **ExCA global control**

Type: Read only, read/write (see individual bit descriptions)

Offset: CardBus socket address + 81Eh; Card A ExCA offset 1Eh

Card B ExCA offset 5Eh

Default: 00h

Description: This register controls both PC Card sockets and is not duplicated for each socket. The host interrupt mode bits in this register are retained for Intel 82365SL-DF compatibility. See Table 51 for a complete description of the register contents.

**Table 51. ExCA Global-Control Register (Index 1Eh)**

BITS	SIGNAL	TYPE	FUNCTION
7-5	RSVD	R	Reserved. Bits 7-5 are read only and returns 0s when read. Write transactions have no effect.
4	INTMODEB	R/W	Level/edge interrupt mode select – card B. Bit 4 selects the signaling mode for the PCI1221 host interrupt for card B interrupts. This bit is encoded as: 0 = Host interrupt is edge mode (default). 1 = Host interrupt is level mode.
3	INTMODEA	R/W	Level/edge interrupt mode select – card A. Bit 3 selects the signaling mode for the PCI1221 host interrupt for card A interrupts. This bit is encoded as: 0 = Host interrupt is edge mode (default). 1 = Host interrupt is level mode.
2	IFCMODE	R/W	Interrupt flag clear mode select. Bit 2 selects the interrupt flag clear mechanism for the flags in the ExCA card status change register. This bit is encoded as: 0 = Interrupt flags are cleared by read of CSC register (default). 1 = Interrupt flags are cleared by explicit write back of 1.
1	CSCMODE	R/W	Card status change level/edge mode select. Bit 1 selects the signaling mode for the PCI1221 host interrupt for card status changes. This bit is encoded as: 0 = Host interrupt is edge mode (default). 1 = Host interrupt is level mode.
0	PWRDWN	R/W	Power-down mode select. When bit 0 is set to 1, the PCI1221 is in power-down mode. In power-down mode, the PCI1221 card outputs are 3-stated until an active cycle is executed on the card interface. Following an active cycle, the outputs are again 3-stated. The PCI1221 still receives functional interrupts, and/or card status change interrupts; however, an actual card access is required to wake up the interface. This bit is encoded as: 0 = Power-down mode is disabled (default). 1 = Power-down mode is enabled.

### ExCA memory window 0–4 page register

Bit	7	6	5	4	3	2	1	0
Name	ExCA memory window 0–4 page							
Type	R/W	R/W	R/W	R/W	R/W	R/W	R/W	R/W
Default	0	0	0	0	0	0	0	0

Register: **ExCA memory window 0–4 page**

Type: Read/write

Offset: CardBus socket address + 840h 841h, 842h, 843h, 844h

Default: 00h

Description: The upper eight bits of a 4-byte PCI memory address are compared to the contents of this register when decoding addresses for 16-bit memory windows. Each window has its own page register, all of which default to 00h. By programming this register to a nonzero value, host software can locate 16-bit memory windows in any one of 256 16M-byte regions in the 4G-byte PCI address space. These registers are only accessible when the ExCA registers are memory mapped, i.e., these registers can not be accessed using the index/data I/O scheme.

### CardBus socket registers (functions 0 and 1)

The PCMCIA CardBus specification requires a CardBus socket controller to provide five 32-bit registers that report and control socket-specific functions. The PCI1221 provides the CardBus socket/ExCA base address register (PCI offset 10h) to locate these CardBus socket registers in PCI memory address space. Each socket has a separate base address register for accessing the CardBus socket registers (see Figure 23). Table 52 gives the location of the socket registers in relation to the CardBus socket/ExCA base address.

The PCI1221 implements an additional register at offset 20h that provides power management control for the socket.

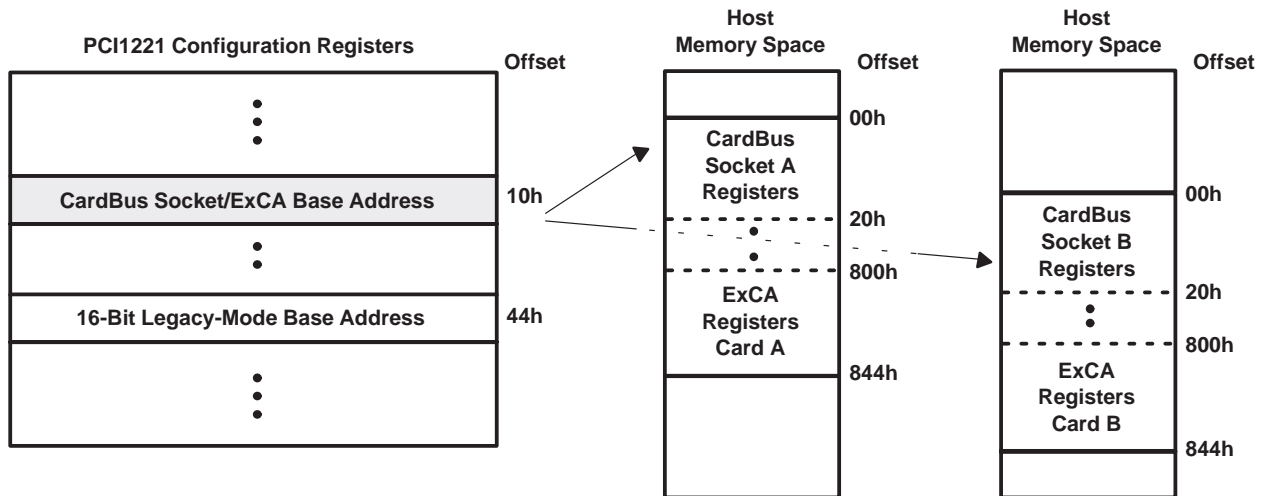

NOTE: The CardBus socket/ExCA base address mode register is separate for functions 0 and 1.

Figure 23. Accessing CardBus Socket Registers Through PCI Memory

**Table 52. CardBus Socket Registers**

REGISTER NAME	OFFSET
Socket event	00h
Socket mask	04h
Socket present state	08h
Socket force event	0Ch
Socket control	10h
Reserved	14h
Reserved	18h
Reserved	1Ch
Socket Power Management	20h

**socket event register**

Bit	31	30	29	28	27	26	25	24	23	22	21	20	19	18	17	16
Name	Socket event															
Type	R	R	R	R	R	R	R	R	R	R	R	R	R	R	R	R
Default	0	0	0	0	0	0	0	0	0	0	0	0	0	0	0	0
Bit	15	14	13	12	11	10	9	8	7	6	5	4	3	2	1	0
Name	Socket event															
Type	R	R	R	R	R	R	R	R	R	R	R	R	R/C	R/C	R/C	R/C
Default	0	0	0	0	0	0	0	0	0	0	0	0	0	0	0	0

Register: **Socket event**

Type: Read only, read/write, read/clear (see individual bit descriptions)

Offset: CardBus socket address + 00h

Default: 0000 0000h

Description: The socket event register indicates a change in socket status has occurred. These bits do not indicate what the change is, only that one has occurred. Software must read the socket present state register for current status. Each bit in this register can be cleared by writing a 1 to that bit. The bits in this register can be set to a 1 by software by writing a 1 to the corresponding bit in the socket force event register. All bits in this register are cleared by PCI reset. They can be immediately set again, if, when coming out of PC Card reset, the bridge finds the status unchanged (i.e., CSTSCHG reasserted or card detect is still true). Software must clear this register before enabling interrupts. If it is not cleared, when interrupts are enabled an interrupt is generated (but not masked) based on any bit set. See Table 53 for a complete description of the register contents.

**Table 53. Socket Event Register**

BIT	SIGNAL	TYPE	FUNCTION
31-4	RSVD	R	Reserved. Bits 31-4 are read only and return 0s when read.
3	PWREVENT	R/C	Power cycle. Bit 3 is set when the PCI1221 detects that the PWRCYCLE bit in the socket present-state register has changed. This bit is cleared by writing a 1.
2	CD2EVENT	R/C	CCD2. Bit 2 is set when the PCI1221 detects that the CDETECT2 field in the socket present-state register has changed. This bit is cleared by writing a 1.
1	CD1EVENT	R/C	CCD1. Bit 3 is set when the PCI1221 detects that the CDETECT1 field in the socket present-state register has changed. This bit is cleared by writing a 1.
0	CSTSEVENT	R/C	CSTSCHG. Bit 0 is set when the CARDSTS field in the socket present-state register has changed state. For CardBus cards, bit 0 is set on the rising edge of CSTSCHG. For 16-bit PC Cards, bit 0 is set on both transitions of CSTSCHG. This bit is reset by writing a 1.



### socket mask register

Bit	31	30	29	28	27	26	25	24	23	22	21	20	19	18	17	16
Name	Socket mask															
Type	R	R	R	R	R	R	R	R	R	R	R	R	R	R	R	R
Default	0	0	0	0	0	0	0	0	0	0	0	0	0	0	0	0
Bit	15	14	13	12	11	10	9	8	7	6	5	4	3	2	1	0
Name	Socket mask															
Type	R	R	R	R	R	R	R	R	R	R	R	R	R/W	R/W	R/W	R/W
Default	0	0	0	0	0	0	0	0	0	0	0	0	0	0	0	0

Register: **Socket mask**

Type: Read only, read/write (see individual bit descriptions)

Offset: CardBus socket address + 04h

Default: 0000 0000h

Description: The socket mask register allows software to control the CardBus card events that generate a status change interrupt. The state of these mask bits does not prevent the corresponding bits from reacting in the socket event register. See Table 54 for a complete description of the register contents.

**Table 54. Socket Mask Register**

BIT	SIGNAL	TYPE	FUNCTION
31-4	RSVD	R	Reserved. Bits 31-4 are read only and return 0s when read.
3	PWRMASK	R/W	Power cycle. Bit 3 masks the PWRCYCLE bit in the socket present state register from causing a status change interrupt. 0 = PWRCYCLE event does not cause CSC interrupt (default). 1 = PWRCYCLE event causes CSC interrupt.
2-1	CDMASK	R/W	Card detect mask. Bits 2-1 mask the CDETECT1 and CDETECT2 bits in the socket present-state register from causing a CSC interrupt. 00 = Insertion/removal does not cause CSC interrupt (default). 01 = Reserved (undefined) 10 = Reserved (undefined) 11 = Insertion/removal causes CSC interrupt.
0	CSTSMASK	R/W	CSTSCHG mask. Bit 0 masks the CARDSTS field in the socket present-state register from causing a CSC interrupt. 0 = CARDSTS event does not cause CSC interrupt (default). 1 = CARDSTS event causes CSC interrupt.

---

**socket present-state register**

<b>Bit</b>	<b>31</b>	<b>30</b>	<b>29</b>	<b>28</b>	<b>27</b>	<b>26</b>	<b>25</b>	<b>24</b>	<b>23</b>	<b>22</b>	<b>21</b>	<b>20</b>	<b>19</b>	<b>18</b>	<b>17</b>	<b>16</b>
<b>Name</b>	Socket present state															
<b>Type</b>	R	R	R	R	R	R	R	R	R	R	R	R	R	R	R	R
<b>Default</b>	0	0	1	1	0	0	0	0	0	0	0	0	0	0	0	0
<b>Bit</b>	<b>15</b>	<b>14</b>	<b>13</b>	<b>12</b>	<b>11</b>	<b>10</b>	<b>9</b>	<b>8</b>	<b>7</b>	<b>6</b>	<b>5</b>	<b>4</b>	<b>3</b>	<b>2</b>	<b>1</b>	<b>0</b>
<b>Name</b>	Socket present state															
<b>Type</b>	R	R	R	R	R	R	R	R	R	R	R	R	R	R	R	R
<b>Default</b>	0	0	0	0	0	0	0	0	0	0	X	0	0	0	X	X

Register: **Socket present state**

Type: Read only

Offset: CardBus socket address + 08h

Default: 3000 00XXh

Description: The socket present-state register reports information about the socket interface. Write transactions to the socket force event register are reflected here, as well as general socket interface status. Information about PC Card  $V_{CC}$  support and card type is only updated at each insertion. Also note that the PCI1221 uses CCD1 and CCD2 during card identification, and changes on these signals during this operation are not reflected in this register. See Table 55 for a complete description of the register contents.

**Table 55. Socket Present-State Register**

BIT	SIGNAL	TYPE	FUNCTION
31	YVSOCKET	R	YV socket. Bit 31 indicates whether or not the socket can supply $V_{CC} = Y.Y V$ to PC Cards. The PCI1221 does not support $Y.Y-V V_{CC}$ ; therefore, this bit is always reset unless overridden by the socket force event register. This bit is hardwired to 0.
30	XVSOCKET	R	XV socket. Bit 30 indicates whether or not the socket can supply $V_{CC} = X.X V$ to PC Cards. The PCI1221 does not support $X.X-V V_{CC}$ ; therefore, this bit is always reset unless overridden by the socket force event register. This bit is hardwired to 0.
29	3VSOCKET	R	3-V socket. Bit 29 indicates whether or not the socket can supply $V_{CC} = 3.3 V$ to PC Cards. The PCI1221 does support 3.3-V $V_{CC}$ ; therefore, this bit is always set unless overridden by the socket force event register.
28	5VSOCKET	R	5-V socket. Bit 28 indicates whether or not the socket can supply $V_{CC} = 5 V$ to PC Cards. The PCI1221 does support 5-V $V_{CC}$ ; therefore, this bit is always set unless overridden by the socket force event register.
27-14	RSVD	R	Reserved. Bits 27-14 are read only and return 0s when read.
13	YVCARD	R	YV card. Bit 13 indicates whether or not the PC Card inserted in the socket supports $V_{CC} = Y.Y V$ .
12	XVCARD	R	XV card. Bit 12 indicates whether or not the PC Card inserted in the socket supports $V_{CC} = X.X V$ .
11	3VCARD	R	3-V card. Bit 11 indicates whether or not the PC Card inserted in the socket supports $V_{CC} = 3.3 V$ .
10	5VCARD	R	5-V card. Bit 10 indicates whether or not the PC Card inserted in the socket supports $V_{CC} = 5 V$ .
9	BADVCCREQ	R	Bad $V_{CC}$ request. Bit 9 indicates that the host software has requested that the socket be powered at an invalid voltage. 0 = Normal operation (default) 1 = Invalid $V_{CC}$ request by host software
8	DATALOST	R	Data lost. Bit 8 indicates that a PC Card removal event may have caused lost data because the cycle did not terminate properly or because write data still resides in the PCI1221. 0 = Normal operation (default) 1 = Potential data loss due to card removal
7	NOTACARD	R	Not a card. Bit 7 indicates that an unrecognizable PC Card has been inserted in the socket. This bit is not updated until a valid PC Card is inserted into the socket. 0 = Normal operation (default) 1 = Unrecognizable PC Card detected
6	IREQCINT	R	$READY(\overline{IREQ})/\overline{CINT}$ . Bit 6 indicates the current status of $READY(\overline{IREQ})/\overline{CINT}$ at the PC Card interface. 0 = $READY(\overline{IREQ})/\overline{CINT}$ low 1 = $READY(\overline{IREQ})/\overline{CINT}$ high
5	CBCARD	R	CardBus card detected. Bit 5 indicates that a CardBus PC Card is inserted in the socket. This bit is not updated until another card interrogation sequence occurs (card insertion).
4	16BITCARD	R	16-bit card detected. Bit 4 indicates that a 16-bit PC Card is inserted in the socket. This bit is not updated until another card interrogation sequence occurs (card insertion).
3	PWRCYCLE	R	Power cycle. Bit 3 indicates that the status of each card powering request. This bit is encoded as: 0 = Socket powered down (default) 1 = Socket powered up
2	CDETECT2	R	$\overline{CCD2}$ . Bit 2 reflects the current status of $\overline{CCD2}$ at the PC Card interface. Changes to this signal during card interrogation are not reflected here. 0 = $\overline{CCD2}$ low (PC Card may be present) 1 = $\overline{CCD2}$ high (PC Card not present)
1	CDETECT1	R	$\overline{CCD1}$ . Bit 1 reflects the current status of $\overline{CCD1}$ at the PC Card interface. Changes to this signal during card interrogation are not reflected here. 0 = $\overline{CCD1}$ low (PC Card may be present) 1 = $\overline{CCD1}$ high (PC Card not present)
0	CARDSTS	R	CSTSCHG. Bit 0 reflects the current status of CSTSCHG at the PC Card interface. 0 = CSTSCHG low 1 = CSTSCHG high

### socket force event register

Bit	31	30	29	28	27	26	25	24	23	22	21	20	19	18	17	16
Name	Socket force event															
Type	R	R	R	R	R	R	R	R	R	R	R	R	R	R	R	R
Default	0	0	0	0	0	0	0	0	0	0	0	0	0	0	0	0
Bit	15	14	13	12	11	10	9	8	7	6	5	4	3	2	1	0
Name	Socket force event															
Type	R	W	W	W	W	W	W	W	W	R	W	W	W	W	W	W
Default	0	0	0	0	0	0	0	0	0	0	0	0	0	0	0	0

Register: **Socket force event**

Type: Read only, write only (see individual bit descriptions)

Offset: CardBus socket address + 0Ch

Default: 0000 0000h

Description: The socket force event register is used to force changes to the socket event register and the socket present state register. The CVSTEST bit in this register must be written when forcing changes that require card interrogation. See Table 56 for a complete description of the register contents.

**Table 56. Socket Force Event Register**

BIT	SIGNAL	TYPE	FUNCTION
31-15	RSVD	R	Reserved. Bits 31-15 are read only and return 0s when read.
14	CVSTEST	W	Card VS test. When bit 14 is set, the PCI1221 re-interrogates the PC Card, updates the socket present state register, and enables the socket power control.
13	FVVCARD	W	Force YV card. Write transactions to bit 13 cause the YVCARD bit in the socket present state register to be written. When set, this bit disables the socket power control.
12	FXVCARD	W	Force XV card. Write transactions to bit 12 cause the XVCARD bit in the socket present state register to be written. When set, this bit disables the socket power control.
11	F3VCARD	W	Force 3-V card. Write transactions to bit 11 cause the 3VCARD bit in the socket present state register to be written. When set, this bit disables the socket power control.
10	F5VCARD	W	Force 5-V card. Write transactions to bit 10 cause the 5VCARD bit in the socket present state register to be written. When set, this bit disables the socket power control.
9	FBADVCCREQ	W	Force bad V <sub>CC</sub> request. Changes to the BADVCCREQ bit in the socket present state register can be made by writing to bit 9.
8	FDATALOST	W	Force data lost. Write transactions to bit 8 cause the DATALOST bit in the socket present state register to be written.
7	FNOTACARD	W	Force not a card. Write transactions to bit 7 cause the NOTACARD bit in the socket present state register to be written.
6	RSVD	R	Reserved. Bit 6 is read only and returns 0 when read.
5	FCBCARD	W	Force CardBus card. Write transactions to bit 5 cause the CBCARD bit in the socket present state register to be written.
4	F16BITCARD	W	Force 16-bit card. Write transactions to bit 4 cause the 16BITCARD bit in the socket present state register to be written.
3	FPWRCYCLE	W	Force power cycle. Write transactions to bit 3 cause the PWREVENT bit in the socket event register to be written, and the PWRCYCLE bit in the socket present state register is unaffected.
2	FCDETECT2	W	Force $\overline{\text{CD2}}$ . Write transactions to bit 2 cause the CD2EVENT bit in the socket event register to be written, and the CDETECT2 bit in the socket present state register is unaffected.
1	FCDETECT1	W	Force $\overline{\text{CD1}}$ . Write transactions to bit 1 cause the CD1EVENT bit in the socket event register to be written, and the CDETECT1 bit in the socket present state register is unaffected.
0	FCARDSTS	W	Force CSTSCHG. Write transactions to bit 0 cause the CSTSEVENT bit in the socket event register to be written, and the CARDSTS bit in the socket present state register is unaffected.

### socket control register

Bit	31	30	29	28	27	26	25	24	23	22	21	20	19	18	17	16
Name	Socket control															
Type	R	R	R	R	R	R	R	R	R	R	R	R	R	R	R	R
Default	0	0	0	0	0	0	0	0	0	0	0	0	0	0	0	0
Bit	15	14	13	12	11	10	9	8	7	6	5	4	3	2	1	0
Name	Socket control															
Type	R	R	R	R	R	R	R	R	R/W	R/W	R/W	R/W	R	R/W	R/W	R/W
Default	0	0	0	0	0	0	0	0	0	0	0	0	0	0	0	0

Register: **Socket control**

Type: Read only, read/write (see individual bit descriptions)

Offset: CardBus socket address + 10h

Default: 0000 0000h

Description: The socket control register provides control of the voltages applied to the socket and instructions for CB  $\overline{\text{CLKRUN}}$  protocol. The PCI1221 ensures that the socket is powered up only at acceptable voltages when a CardBus card is inserted. See Table 57 for a complete description of the register contents.

**Table 57. Socket Control Register**

BIT	SIGNAL	TYPE	FUNCTION
31–8	RSVD	R	Reserved. Bits 31–8 are read only and return 0s when read.
7	STOPCLK	R/W	CB $\overline{\text{CLKRUN}}$ protocol instructions. 0 = CB $\overline{\text{CLKRUN}}$ protocol can only attempt to stop/slow the CB clock if the socket is idle and the PCI $\overline{\text{CLKRUN}}$ protocol is preparing to stop/slow the PCI bus clock. 1 = CB $\overline{\text{CLKRUN}}$ protocol can attempt to stop/slow the CB clock if the socket is idle.
6–4	VCCCTRL	R/W	VCC control. Bits 6–4 are used to request card VCC changes. 000 = Request power off (default) 001 = Reserved 010 = Request VCC = 5 V 011 = Request VCC = 3.3 V 100 = Request VCC = X.X V 101 = Request VCC = Y.Y V 110 = Reserved 111 = Reserved
3	RSVD	R	Reserved. Bit 3 is read only and returns 0 when read.
2–0	VPPCTRL	R/W	Vpp control. Bits 2–0 are used to request card Vpp changes. 000 = Request power off (default) 001 = Request Vpp = 12 V 010 = Request Vpp = 5 V 011 = Request Vpp = 3.3 V 100 = Request Vpp = X.X V 101 = Request Vpp = Y.Y V 110 = Reserved 111 = Reserved

**socket power management register**

Bit	31	30	29	28	27	26	25	24	23	22	21	20	19	18	17	16
Name	Socket power management															
Type	R	R	R	R	R	R	R	R	R	R	R	R	R	R	R	R/W
Default	0	0	0	0	0	0	0	0	0	0	0	0	0	0	0	0
Bit	15	14	13	12	11	10	9	8	7	6	5	4	3	2	1	0
Name	Socket power management															
Type	R	R	R	R	R	R	R	R	R	R	R	R	R	R	R	R/W
Default	0	0	0	0	0	0	0	0	0	0	0	0	0	0	0	0

Register: **Socket power management**

Type: Read only, read/write (see individual bit descriptions)

Offset: CardBus socket address + 20h

Default: 0000 0000h

Description: This register provides power management control over the socket through a mechanism for slowing or stopping the clock on the card interface when the card is idle. See Table 58 for a complete description of the register contents.

**Table 58. Socket Power Management Register**

BIT	SIGNAL	TYPE	FUNCTION
31-26	RSVD	R	Reserved. Bits 31-26 are read only and return 0s when read.
25	SKTACCES	R	Socket access status. This bit provides information on when a socket access has occurred. This bit is cleared by a read access. 0 = A PC card access has not occurred (default). 1 = A PC card access has occurred.
24	SKTMODE	R	Socket mode status. This bit provides clock mode information. 0 = Clock is operating normally. 1 = Clock frequency has changed.
23-17	RSVD	R	Reserved. Bits 23-17 are read only and return 0s when read.
16	CLKCTRLLEN	R/W	CardBus clock control enable. When bit 16 is set, clock control (CLKCTRL bit 0) is enabled. 0 = Clock control is disabled (default). 1 = Clock control is enabled.
15-1	RSVD	R	Reserved. Bits 15-1 are read only and return 0s when read.
0	CLKCTRL	R/W	CardBus clock control. This bit determines whether the CB <u>CLKRUN</u> protocol will attempt to stop or slow the CB clock during idle states. Bit 16 enables this bit. 0 = Allows CB <u>CLKRUN</u> protocol to stop the CB clock (default). 1 = Allows CB <u>CLKRUN</u> protocol to slow the CB clock by a factor of 16.

**absolute maximum ratings over operating temperature ranges (unless otherwise noted)†**

Supply voltage range, $V_{CC}$ .....	-0.5 V to 4.6 V
Clamping voltage range, $V_{CCP}$ , $V_{CCA}$ , $V_{CCB}$ , $V_{CCI}$ .....	-0.5 V to 6 V
Input voltage range, $V_I$ : PCI .....	-0.5 V to $V_{CCP} + 0.5$ V
Card A .....	-0.5 to $V_{CCA} + 0.5$ V
Card B .....	-0.5 to $V_{CCB} + 0.5$ V
MISC .....	-0.5 to $V_{CCI} + 0.5$ V
Fail safe .....	-0.5 V to $V_{CC} + 0.5$ V
Output voltage range, $V_O$ : PCI .....	-0.5 V to $V_{CCP} + 0.5$ V
Card A .....	-0.5 to $V_{CCA} + 0.5$ V
Card B .....	-0.5 to $V_{CCB} + 0.5$ V
MISC .....	-0.5 to $V_{CCI} + 0.5$ V
Fail safe .....	-0.5 V to $V_{CC} + 0.5$ V
Input clamp current, $I_{IK}$ ( $V_I < 0$ or $V_I > V_{CC}$ ) (see Note 1) .....	$\pm 20$ mA
Output clamp current, $I_{OK}$ ( $V_O < 0$ or $V_O > V_{CC}$ ) (see Note 2) .....	$\pm 20$ mA
Storage temperature range, $T_{stg}$ .....	-65°C to 150°C
Virtual junction temperature, $T_J$ .....	150°C

† Stresses beyond those listed under “absolute maximum ratings” may cause permanent damage to the device. These are stress ratings only, and functional operation of the device at these or any other conditions beyond those indicated under “recommended operating conditions” is not implied. Exposure to absolute-maximum-rated conditions for extended periods may affect device reliability.

- NOTES: 1. Applies for external input and bidirectional buffers.  $V_I > V_{CC}$  does not apply to fail-safe terminals. PCI terminals are measured with respect to  $V_{CCP}$  instead of  $V_{CC}$ . PC Card terminals are measured with respect to  $V_{CCA}$  or  $V_{CCB}$ . Miscellaneous signals are measured with respect to  $V_{CCI}$ . The limit specified applies for a dc condition.
2. Applies for external output and bidirectional buffers.  $V_O > V_{CC}$  does not apply to fail-safe terminals. PCI terminals are measured with respect to  $V_{CCP}$  instead of  $V_{CC}$ . PC Card terminals are measured with respect to  $V_{CCA}$  or  $V_{CCB}$ . Miscellaneous signals are measured with respect to  $V_{CCI}$ . The limit specified applies for a dc condition.

**recommended operating conditions (see Note 3)**

			OPERATION	MIN	NOM	MAX	UNIT
V <sub>CC</sub>	Core voltage	Commercial	3.3 V	3	3.3	3.6	V
V <sub>CCP</sub>	PCI I/O clamping voltage	Commercial	3.3 V	3	3.3	3.6	V
			5 V	4.75	5	5.25	
V <sub>CCA</sub> V <sub>CCB</sub>	PC Card I/O clamping voltage	Commercial	3.3 V	3	3.3	3.6	V
			5 V	4.75	5	5.25	
V <sub>CCI</sub>	Miscellaneous I/O clamping voltage	Commercial	3.3 V	3	3.3	3.6	V
			5 V	4.75	5	5.25	
V <sub>IH</sub> <sup>†</sup>	High-level input voltage	PCI	3.3 V	0.5 V <sub>CCP</sub>		V <sub>CCP</sub>	V
			5 V	2		V <sub>CCP</sub>	
		PC Card	3.3 V	0.475 V <sub>CCA/B</sub>		V <sub>CCA/B</sub>	
			5 V	2.4		V <sub>CCA/B</sub>	
		MISC <sup>‡</sup>		2		V <sub>CCI</sub>	
Fail safe <sup>§</sup>		2		V <sub>CC</sub>			
V <sub>IL</sub> <sup>†</sup>	Low-level input voltage	PCI	3.3 V	0		0.3 V <sub>CCP</sub>	V
			5 V	0		0.8	
		PC Card	3.3 V	0		0.325 V <sub>CCA/B</sub>	
			5 V	0		0.8	
		MISC <sup>‡</sup>		0		0.8	
Fail safe <sup>§</sup>		0		0.8			
V <sub>I</sub>	Input voltage	PCI		0		V <sub>CCP</sub>	V
		PC Card		0		V <sub>CCA/B</sub>	
		MISC <sup>‡</sup>		0		V <sub>CCI</sub>	
		Fail safe <sup>§</sup>		0		V <sub>CC</sub>	
V <sub>O</sub> <sup>¶</sup>	Output voltage	PCI		0		V <sub>CC</sub>	V
		PC Card		0		V <sub>CC</sub>	
		MISC <sup>‡</sup>		0		V <sub>CC</sub>	
		Fail safe <sup>§</sup>		0		V <sub>CC</sub>	
t <sub>t</sub>	Input transition time (t <sub>r</sub> and t <sub>f</sub> )	PCI and PC Card		1		4	ns
		Miscellaneous and fail safe		0		6	
T <sub>A</sub>	Operating ambient temperature range			0	25	70	°C
T <sub>J</sub> <sup>#</sup>	Virtual junction temperature			0	25	115	°C

NOTE 3: Unused pins (input or I/O) must be held high or low to prevent them from floating.

<sup>†</sup> Applies to external inputs and bidirectional buffers without hysteresis

<sup>‡</sup> Miscellaneous pins are 149, 150, 151, 152, 154, 155, 156, 157, 158, 159, 161, 163 for the PDV packaged device and G15, F17, E19, F14, F15, E17, D19, A16, A16, C15, C15, E14, B15 and C14 for the GHK packaged device (SUSPEND, SPKROUT, RI\_OUT, multifunction terminals (MFUNC0–6), and power switch control pins).

<sup>§</sup> Fail-safe pins are 16, 56, 68, 74, 82, 122, 134, and 140 for the PDV packaged device and H3, P7, U8, R9, V11, M19, J18, and H17 for the GHK packaged device (card detect and voltage sense pins).

<sup>¶</sup> Applies to external output buffers

<sup>#</sup> These junction temperatures reflect simulation conditions. The customer is responsible for verifying junction temperature.



**electrical characteristics over recommended operating conditions (unless otherwise noted)**

PARAMETER	PINS	OPERATION	TEST CONDITIONS	MIN	MAX	UNIT
V <sub>OH</sub> High-level output voltage	PCI	3.3 V	I <sub>OH</sub> = -0.5 mA	0.9 V <sub>CC</sub>		V
		5 V	I <sub>OH</sub> = -2 mA	2.4		
	PC Card	3.3 V	I <sub>OH</sub> = -0.15 mA	0.9 V <sub>CC</sub>		
		5 V	I <sub>OH</sub> = -0.15 mA	2.4		
	MISC		I <sub>OH</sub> = -4 mA	V <sub>CC</sub> -0.6		
V <sub>OL</sub> Low-level output voltage	PCI	3.3 V	I <sub>OL</sub> = 1.5 mA	0.1 V <sub>CC</sub>		V
		5 V	I <sub>OL</sub> = 6 mA	0.55		
	PC Card	3.3 V	I <sub>OL</sub> = 0.7 mA	0.1 V <sub>CC</sub>		
		5 V	I <sub>OL</sub> = 0.7 mA	0.55		
	MISC		I <sub>OL</sub> = 4 mA	0.5		
	SERR		I <sub>OL</sub> = 12 mA	0.5		
I <sub>OZL</sub> 3-state, high-impedance low-level output current	Output pins	3.6 V	V <sub>I</sub> = V <sub>CC</sub>		-1	μA
		5.25 V	V <sub>I</sub> = V <sub>CC</sub>		-1	
I <sub>OZH</sub> 3-state, high-impedance high-level output current	Output pins	3.6 V	V <sub>I</sub> = V <sub>CC</sub> <sup>†</sup>		10	μA
		5.25 V	V <sub>I</sub> = V <sub>CC</sub> <sup>†</sup>		25	
I <sub>IL</sub> Low-level input current	Input pins		V <sub>I</sub> = GND		-1	μA
	I/O pins		V <sub>I</sub> = GND		-10	
I <sub>IH</sub> High-level input current	Input pins	3.6 V	V <sub>I</sub> = V <sub>CC</sub> <sup>‡</sup>		10	μA
		5.25 V	V <sub>I</sub> = V <sub>CC</sub> <sup>‡</sup>		20	
	I/O pins	3.6 V	V <sub>I</sub> = V <sub>CC</sub> <sup>‡</sup>		10	
		5.25 V	V <sub>I</sub> = V <sub>CC</sub> <sup>‡</sup>		25	
	Fail-safe pins	3.6 V	V <sub>I</sub> = V <sub>CC</sub>		10	

<sup>†</sup> For PCI pins, V<sub>I</sub> = V<sub>CCP</sub>. For PC Card pins, V<sub>I</sub> = V<sub>CC(A/B)</sub>. For miscellaneous pins, V<sub>I</sub> = V<sub>CC1</sub>

<sup>‡</sup> For I/O pins, input leakage (I<sub>IL</sub> and I<sub>IH</sub>) includes I<sub>OZ</sub> leakage of the disabled output.

**PCI clock/reset timing requirements over recommended ranges of supply voltage and operating free-air temperature (see Figure 25 and Figure 26)**

PARAMETER		ALTERNATE SYMBOL	TEST CONDITIONS	MIN	MAX	UNIT
t <sub>c</sub>	Cycle time, PCLK	t <sub>cyc</sub>		30		ns
t <sub>wH</sub>	Pulse duration (width), PCLK high	t <sub>high</sub>		11		ns
t <sub>wL</sub>	Pulse duration (width), PCLK low	t <sub>low</sub>		11		ns
Δv/Δt	Slew rate, PCLK	t <sub>r</sub> , t <sub>f</sub>		1	4	V/ns
t <sub>w</sub>	Pulse duration (width), RSTIN	t <sub>rst</sub>		1		ms
t <sub>su</sub>	Setup time, PCLK active at end of $\overline{\text{RSTIN}}$	t <sub>rst-clk</sub>		100		μs

**PCI timing requirements over recommended ranges of supply voltage and operating free-air temperature (see Note 4 and Figure 24 and Figure 27)**

PARAMETER		ALTERNATE SYMBOL	TEST CONDITIONS	MIN	MAX	UNIT
t <sub>pd</sub>	PCLK-to-shared signal valid delay time	t <sub>val</sub>	C <sub>L</sub> = 50 pF, See Note 5		11	ns
	PCLK-to-shared signal invalid delay time	t <sub>inv</sub>		2		
t <sub>en</sub>	Enable time, high impedance-to-active delay time from PCLK	t <sub>on</sub>		2		ns
t <sub>dis</sub>	Disable time, active-to-high impedance delay time from PCLK	t <sub>off</sub>			28	ns
t <sub>su</sub>	Setup time before PCLK valid	t <sub>su</sub>		7		ns
t <sub>h</sub>	Hold time after PCLK high	t <sub>h</sub>		0		ns

- NOTES: 4. This data sheet uses the following conventions to describe time ( t ) intervals. The format is t<sub>A</sub>, where *subscript A* indicates the type of dynamic parameter being represented. One of the following is used: t<sub>pd</sub> = propagation delay time, t<sub>d</sub> = delay time, t<sub>su</sub> = setup time, and t<sub>h</sub> = hold time.
5. PCI shared signals are AD31-0, C/BE3-0,  $\overline{\text{FRAME}}$ ,  $\overline{\text{TRDY}}$ ,  $\overline{\text{IRDY}}$ ,  $\overline{\text{STOP}}$ ,  $\overline{\text{IDSEL}}$ ,  $\overline{\text{DEVSEL}}$ , and PAR.

## PARAMETER MEASUREMENT INFORMATION

### LOAD CIRCUIT PARAMETERS

TIMING PARAMETER		$C_{LOAD}^{\dagger}$ (pF)	$I_{OL}$ (mA)	$I_{OH}$ (mA)	$V_{LOAD}$ (V)
$t_{en}$	$t_{PZH}$	50	8	-8	0
	$t_{PZL}$				3
$t_{dis}$	$t_{PHZ}$	50	8	-8	1.5
	$t_{PLZ}$				
$t_{pd}$		50	8	-8	‡

†  $C_{LOAD}$  includes the typical load-circuit distributed capacitance

‡  $\frac{V_{LOAD} - V_{OL}}{I_{OL}} = 50 \Omega$ , where  $V_{OL} = 0.6 V$ ,  $I_{OL} = 8 mA$

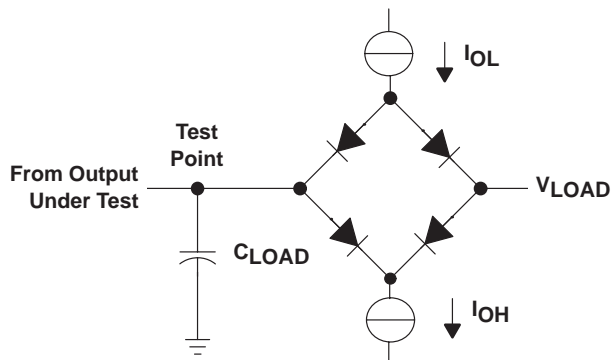

LOAD CIRCUIT

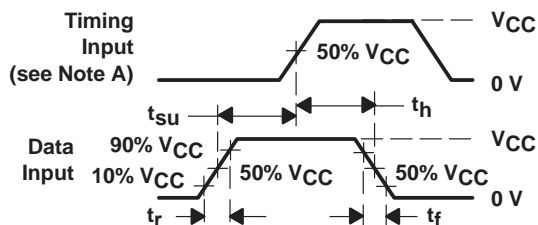

VOLTAGE WAVEFORMS  
SETUP AND HOLD TIMES  
INPUT RISE AND FALL TIMES

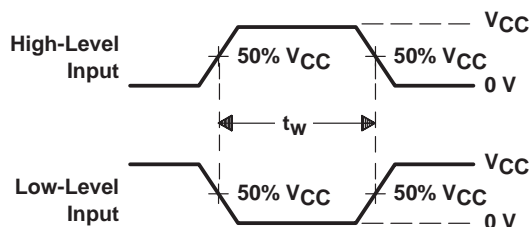

VOLTAGE WAVEFORMS  
PULSE DURATION

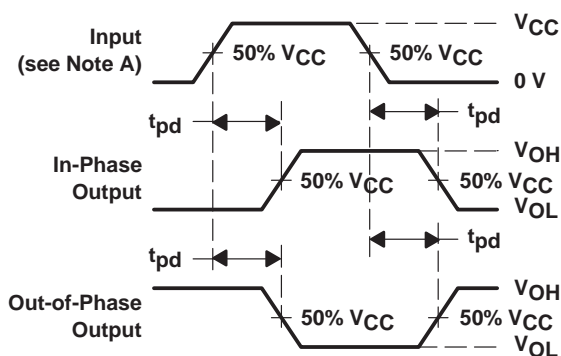

VOLTAGE WAVEFORMS  
PROPAGATION DELAY TIMES

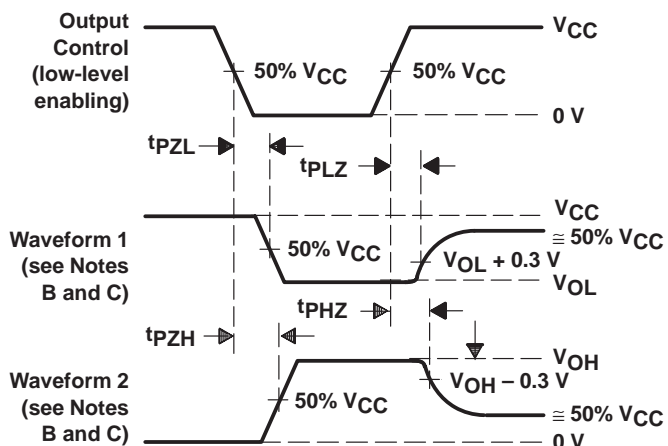

VOLTAGE WAVEFORMS  
ENABLE AND DISABLE TIMES, 3-STATE OUTPUTS

- NOTES: A. Phase relationships between waveforms were chosen arbitrarily. All input pulses are supplied by pulse generators having the following characteristics: PRR = 1 MHz,  $Z_O = 50 \Omega$ ,  $t_r = 6 ns$ .
- B. Waveform 1 is for an output with internal conditions such that the output is low except when disabled by the output control. Waveform 2 is for an output with internal conditions such that the output is high except when disabled by the output control.
- C. For  $t_{PLZ}$  and  $t_{PHZ}$ ,  $V_{OL}$  and  $V_{OH}$  are measured values.

Figure 24. Load Circuit and Voltage Waveforms

## PCI BUS PARAMETER MEASUREMENT INFORMATION

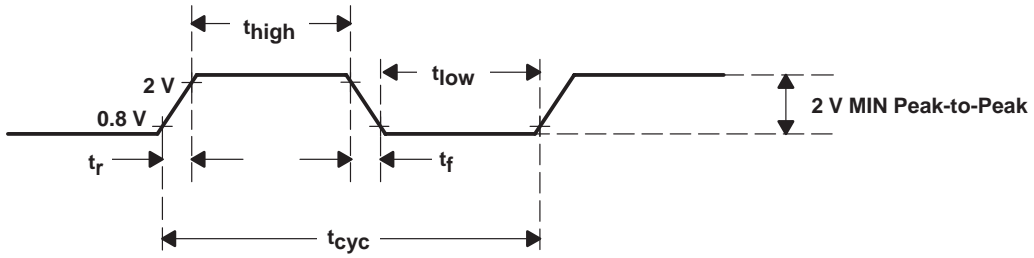

Figure 25. PCLK Timing Waveform

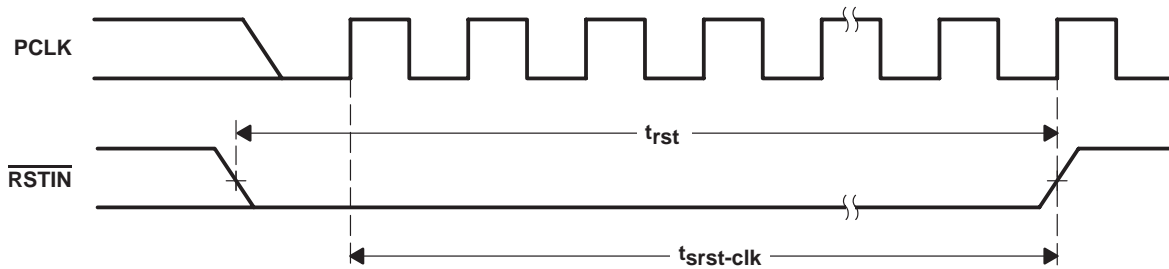

Figure 26.  $\overline{RSTIN}$  Timing Waveforms

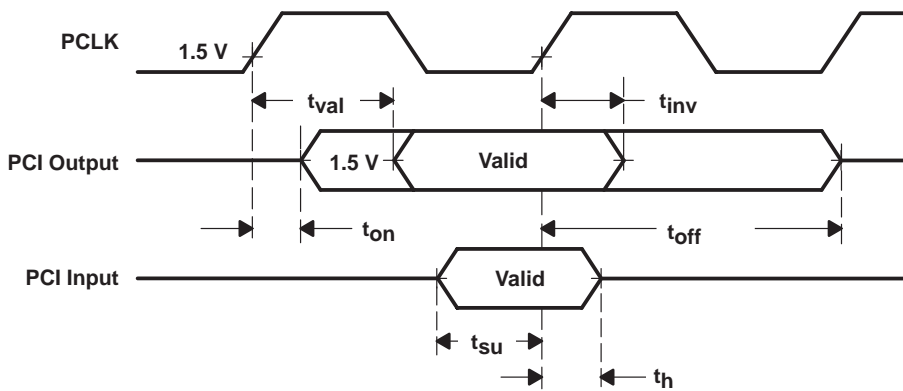

Figure 27. Shared Signals Timing Waveforms

## PC Card cycle timing

The PC Card cycle timing is controlled by the wait-state bits in the Intel 82365SL-DF compatible memory and I/O window registers. The PC Card cycle generator uses the PCI clock to generate the correct card address setup and hold times, and the PC Card command active (low) interval. This allows the cycle generator to output PC Card cycles that are as close to the Intel 82365SL-DF timing as possible, while always slightly exceeding the Intel 82365SL-DF values. This ensures compatibility with existing software and maximizes throughput.

The PC Card address setup and hold times are a function of the wait-state bits. Table 59 shows address setup time in PCLK cycles and nanoseconds for I/O and memory cycles. Table 60 and Table 61 show command active time in PCLK cycles and nanoseconds for I/O and memory cycles. Table 62 shows address hold time in PCLK cycles and nanoseconds for I/O and memory cycles.

**Table 59. PC Card Address Setup Time,  $t_{su(A)}$ , 8-Bit and 16-Bit PCI Cycles**

WAIT-STATE BITS			TS1 – 0 = 01 (PCLK/ns)
I/O			3/90
Memory	WS1	0	2/60
Memory	WS1	1	4/120

**Table 60. PC Card Command Active Time,  $t_{c(A)}$ , 8-Bit PCI Cycles**

	WAIT-STATE BITS		TS1 – 0 = 01 (PCLK/ns)
	WS	ZWS	
I/O	0	0	19/570
	1	X	23/690
	0	1	7/210
Memory	00	0	19/570
	01	X	23/690
	10	X	23/690
	11	X	23/690
	00	1	7/210

**Table 61. PC Card Command Active Time,  $t_{c(A)}$ , 16-Bit PCI Cycles**

	WAIT-STATE BITS		TS1 – 0 = 01 (PCLK/ns)
	WS	ZWS	
I/O	0	0	7/210
	1	X	11/330
	0	1	N/A
Memory	00	0	9/270
	01	X	13/390
	10	X	17/510
	11	X	23/630
	00	1	5/150

**Table 62. PC Card Address Hold Time,  $t_{h(A)}$ , 8-Bit and 16-Bit PCI Cycles**

WAIT-STATE BITS			TS1 – 0 = 01 (PCLK/ns)
I/O			2/60
Memory	WS1	0	2/60
Memory	WS1	1	3/90

**timing requirements over recommended ranges of supply voltage and operating free-air temperature, memory cycles (for 100-ns common memory) (see Note 6 and Figure 28)**

	ALTERNATE SYMBOL	MIN	MAX	UNIT
$t_{su}$ Setup time, $\overline{CE1}$ and $\overline{CE2}$ before $\overline{WE}/\overline{OE}$ low	T1	60		ns
$t_{su}$ Setup time, CA25–CA0 before $\overline{WE}/\overline{OE}$ low	T2	$t_{su(A)}+2PCLK$		ns
$t_{su}$ Setup time, $\overline{REG}$ before $\overline{WE}/\overline{OE}$ low	T3	90		ns
$t_{pd}$ Propagation delay time, $\overline{WE}/\overline{OE}$ low to $\overline{WAIT}$ low	T4			ns
$t_w$ Pulse duration (width), $\overline{WE}/\overline{OE}$ low	T5	200		ns
$t_h$ Hold time, $\overline{WE}/\overline{OE}$ low after $\overline{WAIT}$ high	T6			ns
$t_h$ Hold time, $\overline{CE1}$ and $\overline{CE2}$ after $\overline{WE}/\overline{OE}$ high	T7	120		ns
$t_{su}$ Setup time (read), CDATA15–CDATA0 valid before $\overline{OE}$ high	T8			ns
$t_h$ Hold time (read), CDATA15–CDATA0 valid after $\overline{OE}$ high	T9	0		ns
$t_h$ Hold time, CA25–CA0 and $\overline{REG}$ after $\overline{WE}/\overline{OE}$ high	T10	$t_{h(A)}+1PCLK$		ns
$t_{su}$ Setup time (write), CDATA15–CDATA0 valid before $\overline{WE}$ low	T11	60		ns
$t_h$ Hold time (write), CDATA15–CDATA0 valid after $\overline{WE}$ low	T12	240		ns

NOTE 6: These times are dependent on the register settings associated with ISA wait states and data size. They are also dependent on cycle type (read/write, memory/I/O) and WAIT from PC Card. The times listed here represent absolute minimums (the times that would be observed if programmed for zero wait state, 16-bit cycles) with a 33-MHz PCI clock.

**timing requirements over recommended ranges of supply voltage and operating free-air temperature, I/O cycles (see Figure 29)**

	ALTERNATE SYMBOL	MIN	MAX	UNIT
$t_{su}$ Setup time, $\overline{REG}$ before $\overline{IORD}/\overline{IOWR}$ low	T13	60		ns
$t_{su}$ Setup time, $\overline{CE1}$ and $\overline{CE2}$ before $\overline{IORD}/\overline{IOWR}$ low	T14	60		ns
$t_{su}$ Setup time, CA25–CA0 valid before $\overline{IORD}/\overline{IOWR}$ low	T15	$t_{su(A)}+2PCLK$		ns
$t_{pd}$ Propagation delay time, $\overline{IOIS16}$ low after CA25–CA0 valid	T16		35	ns
$t_{pd}$ Propagation delay time, $\overline{IORD}$ low to $\overline{WAIT}$ low	T17	35		ns
$t_w$ Pulse duration (width), $\overline{IORD}/\overline{IOWR}$ low	T18	$T_{cA}$		ns
$t_h$ Hold time, $\overline{IORD}$ low after $\overline{WAIT}$ high	T19			ns
$t_h$ Hold time, $\overline{REG}$ low after $\overline{IORD}$ high	T20	0		ns
$t_h$ Hold time, $\overline{CE1}$ and $\overline{CE2}$ after $\overline{IORD}/\overline{IOWR}$ high	T21	120		ns
$t_h$ Hold time, CA25–CA0 after $\overline{IORD}/\overline{IOWR}$ high	T22	$t_{h(A)}+1PCLK$		ns
$t_{su}$ Setup time (read), CDATA15–CDATA0 valid before $\overline{IORD}$ high	T23	10		ns
$t_h$ Hold time (read), CDATA15–CDATA0 valid after $\overline{IORD}$ high	T24	0		ns
$t_{su}$ Setup time (write), CDATA15–CDATA0 valid before $\overline{IOWR}$ low	T25	90		ns
$t_h$ Hold time (write), CDATA15–CDATA0 valid after $\overline{IOWR}$ high	T26	90		ns

switching characteristics over recommended ranges of supply voltage and operating free-air temperature, miscellaneous (see Figure 30)

PARAMETER		ALTERNATE SYMBOL	MIN	MAX	UNIT
$t_{pd}$	Propagation delay time	BVD2 low to SPKROUT low		30	ns
		BVD2 high to SPKROUT high	T27	30	
		$\overline{IREQ}$ to IRQ15-IRQ3	T28	30	
		STSCHG to IRQ15-IRQ3		30	

### PC Card PARAMETER MEASUREMENT INFORMATION

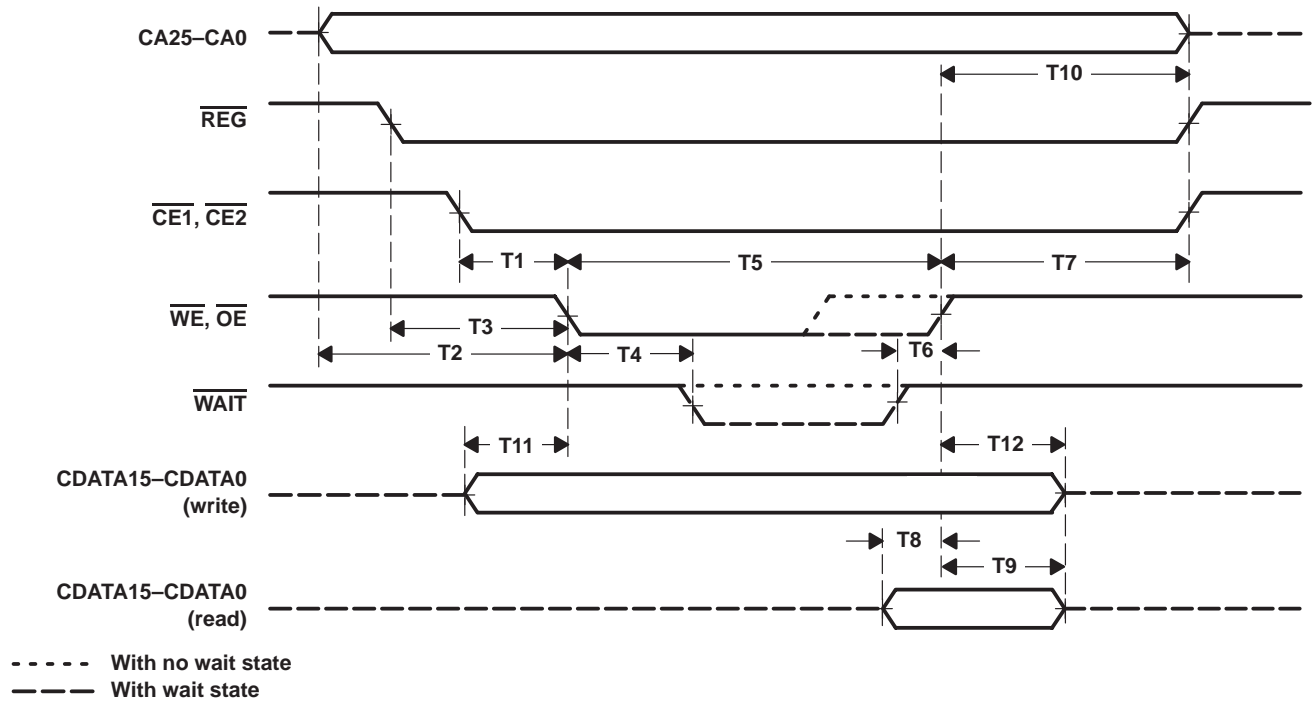

Figure 28. PC Card Memory Cycle

## PC Card PARAMETER MEASUREMENT INFORMATION

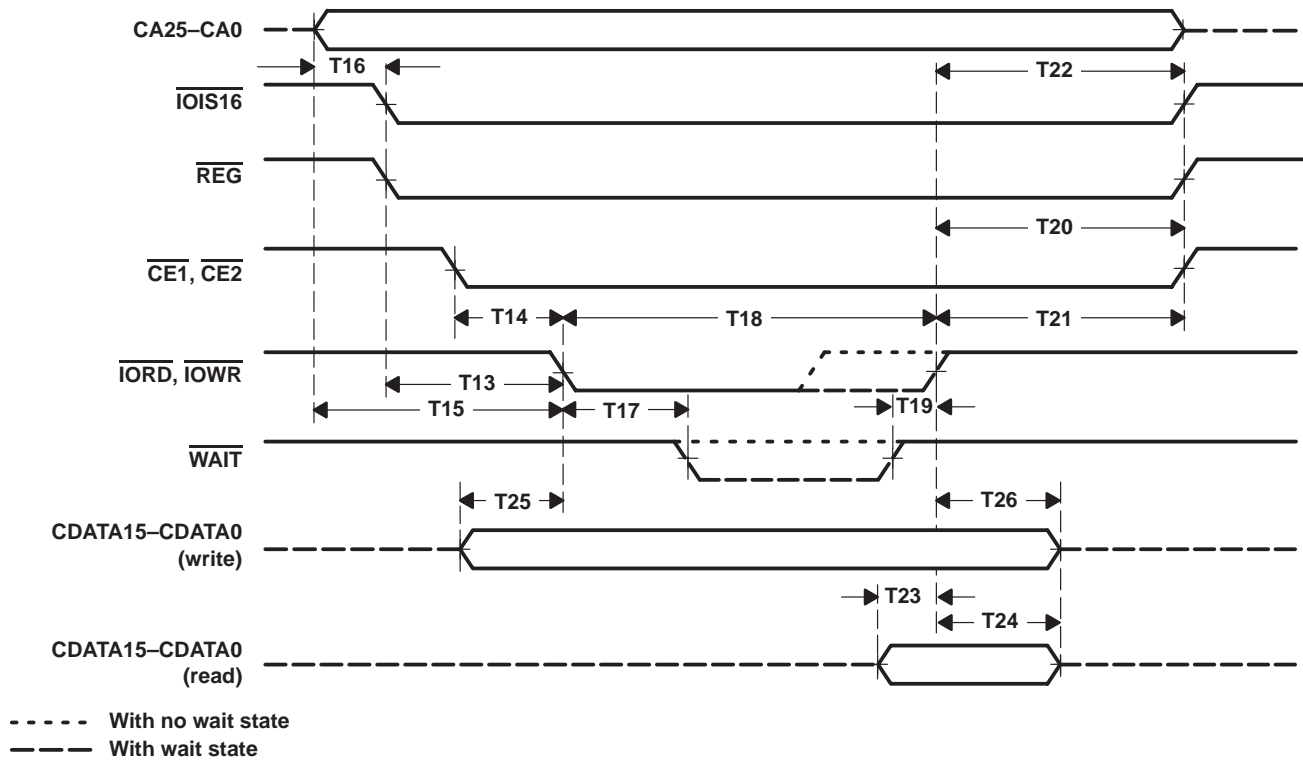

Figure 29. PC Card I/O Cycle

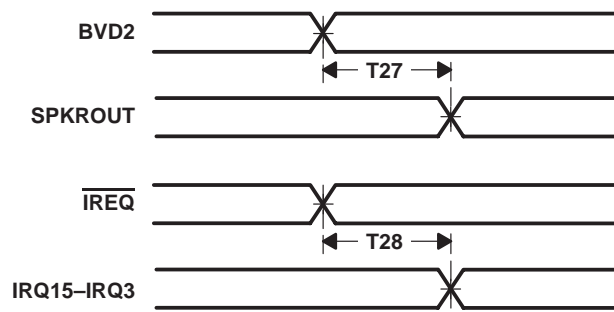

Figure 30. Miscellaneous PC Card Delay Times



# MECHANICAL DATA

GHK (S-PBGA-N209)

PLASTIC BALL GRID ARRAY PACKAGE

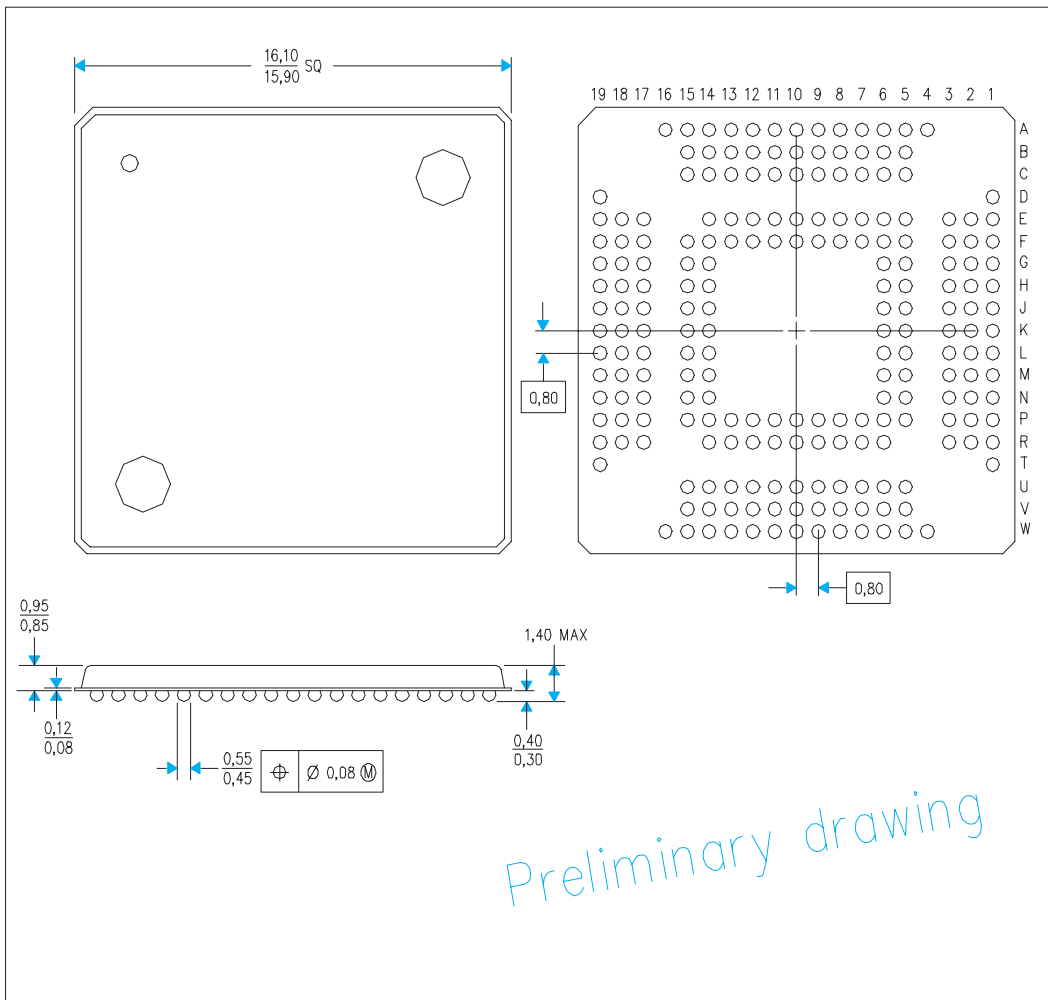

NOTES: A. All linear dimensions are in millimeters.

MECHANICAL DATA

PDV (S-PQFP-G208)

PLASTIC QUAD FLATPACK

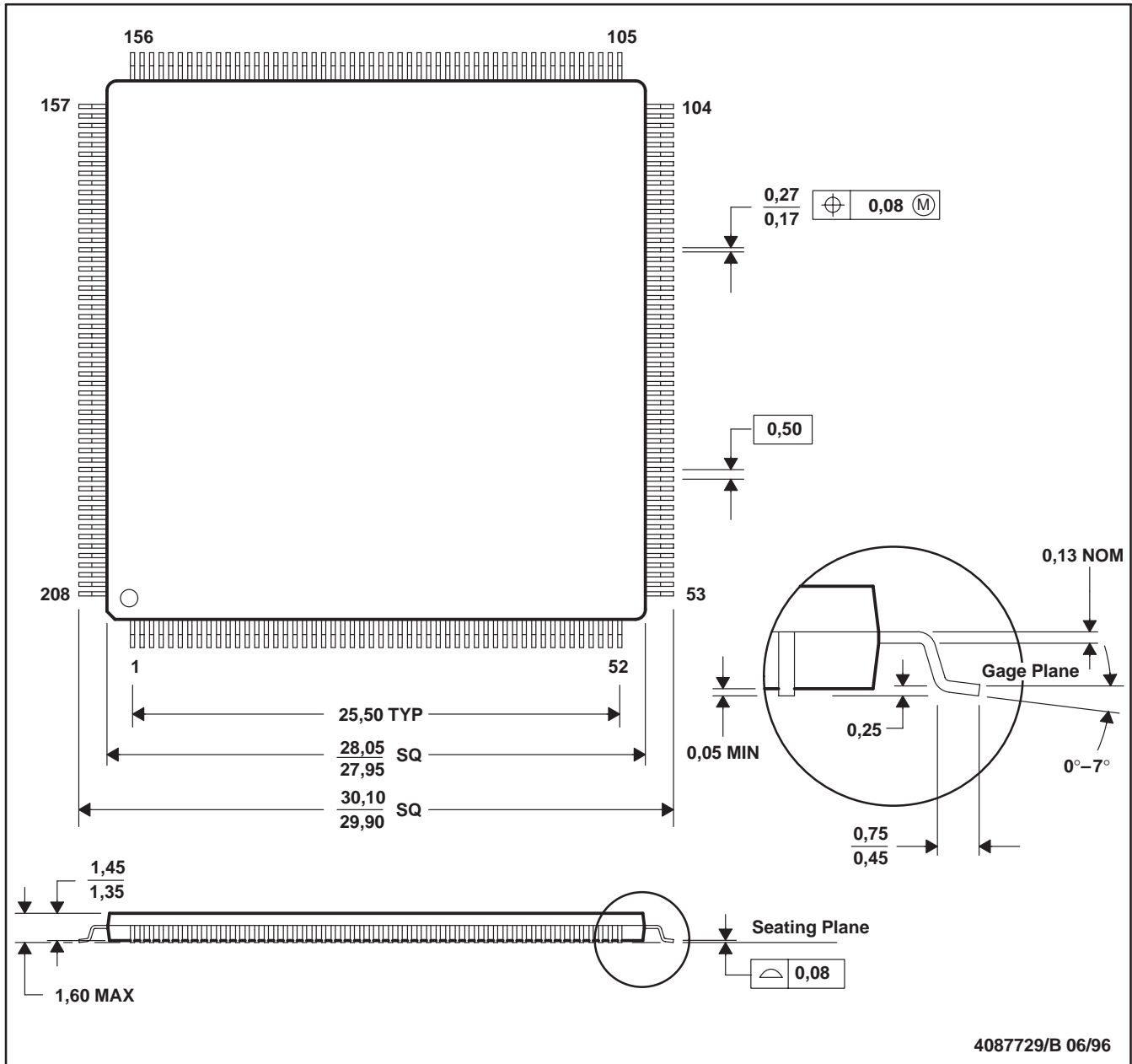

## **IMPORTANT NOTICE**

Texas Instruments and its subsidiaries (TI) reserve the right to make changes to their products or to discontinue any product or service without notice, and advise customers to obtain the latest version of relevant information to verify, before placing orders, that information being relied on is current and complete. All products are sold subject to the terms and conditions of sale supplied at the time of order acknowledgement, including those pertaining to warranty, patent infringement, and limitation of liability.

TI warrants performance of its semiconductor products to the specifications applicable at the time of sale in accordance with TI's standard warranty. Testing and other quality control techniques are utilized to the extent TI deems necessary to support this warranty. Specific testing of all parameters of each device is not necessarily performed, except those mandated by government requirements.

CERTAIN APPLICATIONS USING SEMICONDUCTOR PRODUCTS MAY INVOLVE POTENTIAL RISKS OF DEATH, PERSONAL INJURY, OR SEVERE PROPERTY OR ENVIRONMENTAL DAMAGE ("CRITICAL APPLICATIONS"). TI SEMICONDUCTOR PRODUCTS ARE NOT DESIGNED, AUTHORIZED, OR WARRANTED TO BE SUITABLE FOR USE IN LIFE-SUPPORT DEVICES OR SYSTEMS OR OTHER CRITICAL APPLICATIONS. INCLUSION OF TI PRODUCTS IN SUCH APPLICATIONS IS UNDERSTOOD TO BE FULLY AT THE CUSTOMER'S RISK.

In order to minimize risks associated with the customer's applications, adequate design and operating safeguards must be provided by the customer to minimize inherent or procedural hazards.

TI assumes no liability for applications assistance or customer product design. TI does not warrant or represent that any license, either express or implied, is granted under any patent right, copyright, mask work right, or other intellectual property right of TI covering or relating to any combination, machine, or process in which such semiconductor products or services might be or are used. TI's publication of information regarding any third party's products or services does not constitute TI's approval, warranty or endorsement thereof.