

Features

- 0.54 INCH CHARACTER HEIGHT.
- LOW CURRENT OPERATION.
- HIGH CONTRAST AND LIGHT OUTPUT.
- COMMON CATHODE AND COMMON ANODE AVAILABLE.
- EASY MOUNTING ON P.C. BOARDS OR SOCKETS.
- CATEGORIZED FOR LUMINOUS INTENSITY, YELLOW AND GREEN CATEGORIZED FOR COLOR.
- MECHANICALLY RUGGED.
- STANDARD: GRAY FACE, WHITE SEGMENT.

Description

The High Efficiency Red source color devices are made with Gallium Arsenide Phosphide on Gallium Phosphide Orange Light Emitting Diode.

The Green source color devices are made with Gallium Phosphide Green Light Emitting Diode.

The Yellow source color devices are made with Gallium Arsenide Phosphide on Gallium Phosphide Yellow Light Emitting Diode.

The Super Bright Red source color devices are made with Gallium Aluminum Arsenide Red Light Emitting Diode.

Package Dimensions & Internal Circuit Diagram

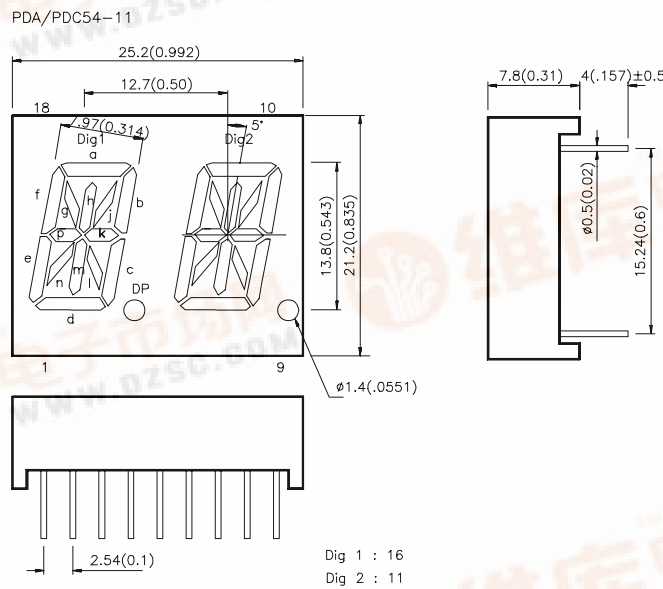

PDA54-11

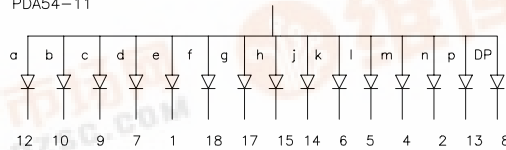

Dig 1 : 16
 Dig 2 : 11

PDC54-11

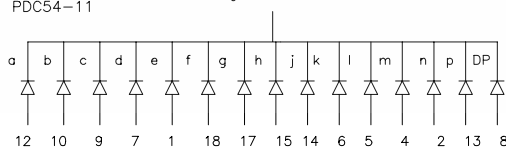

Dig 1 : 16
 Dig 2 : 11

Notes:
 1. All dimensions are in millimeters (inches). Tolerance is ±0.25(0.01") unless otherwise noted.
 2. Specifications are subject to change without notice.



Package Dimensions & Internal Circuit Diagram

PDA/PDC54-12

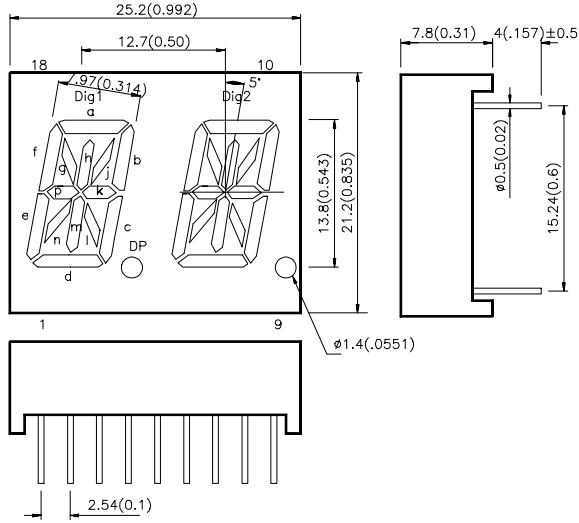

PDA54-12

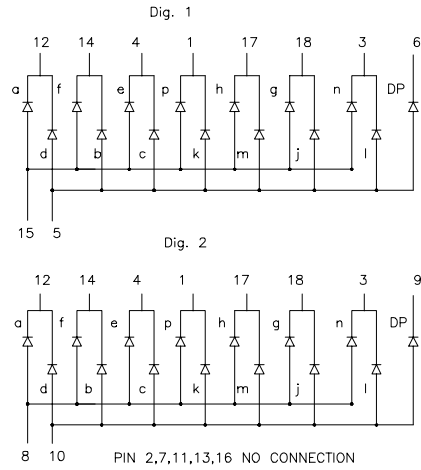

PDC54-12

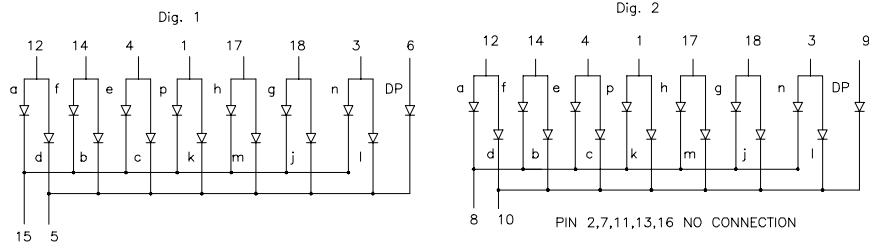

Notes:

1. All dimensions are in millimeters (inches), Tolerance is ±0.25(0.01") unless otherwise noted.
2. Specifications are subject to change without notice.

Selection Guide

Part No.	Dice	Iv (ucd) @ 10 mA		Description
		Min.	Typ.	
PDA54-11EWA PDA54-12EWA	HIGH EFFICIENCY RED (GaAsP/GaP)	1900	4700	Common Anode, Rt. Hand Decimal
PDC54-11EWA PDC54-12EWA				Common Cathode, Rt. Hand Decimal
PDA54-11GWA PDA54-12GWA	GREEN (GaP)	3000	8000	Common Anode, Rt. Hand Decimal
PDC54-11GWA PDC54-12GWA				Common Cathode, Rt. Hand Decimal
PDA54-11YWA PDA54-12YWA	YELLOW (GaAsP/GaP)	1200	3000	Common Anode, Rt. Hand Decimal
PDC54-11YWA PDC54-12YWA				Common Cathode, Rt. Hand Decimal
PDA54-11SRWA PDA54-12SRWA	SUPER BRIGHT RED (GaAlAs)	8000	18000	Common Anode, Rt. Hand Decimal
PDC54-11SRWA PDC54-12SRWA				Common Cathode, Rt. Hand Decimal

Kingbright

Electrical / Optical Characteristics at T_A=25°C

Symbol	Parameter	Device	Typ.	Max.	Units	Test Conditions
λ_{peak}	Peak Wavelength	High Efficiency Red Green Yellow Super Bright Red	627 565 590 660		nm	IF=20mA
λ_D	Dominate Wavelength	High Efficiency Red Green Yellow Super Bright Red	625 568 588 640		nm	IF=20mA
$\Delta\lambda_{1/2}$	Spectral Line Halfwidth	High Efficiency Red Green Yellow Super Bright Red	45 30 35 20		nm	IF=20mA
C	Capacitance	High Efficiency Red Green Yellow Super Bright Red	15 15 20 45		pF	VF=0V;f=1MHz
V _F	Forward Voltage	High Efficiency Red Green Yellow Super Bright Red	2.0 2.2 2.1 1.85	2.5 2.5 2.5 2.5	V	IF=20mA
I _r	Reverse Current	All		10	uA	VR = 5V

Absolute Maximum Ratings at T_A=25°C

Parameter	High Efficiency Red	Green	Yellow	Super Bright Red	Units
Power dissipation	105	105	105	100	mW
DC Forward Current	30	25	30	30	mA
Peak Forward Current [1]	160	140	140	155	mA
Reverse Voltage	5	5	5	5	V
Operating/Storage Temperature	-40°C To +85°C				
Lead Solder Temperature [2]	260°C For 5 Seconds				

Notes:

- 1/10 Duty Cycle, 0.1ms Pulse Width.
2. 4mm below package base.

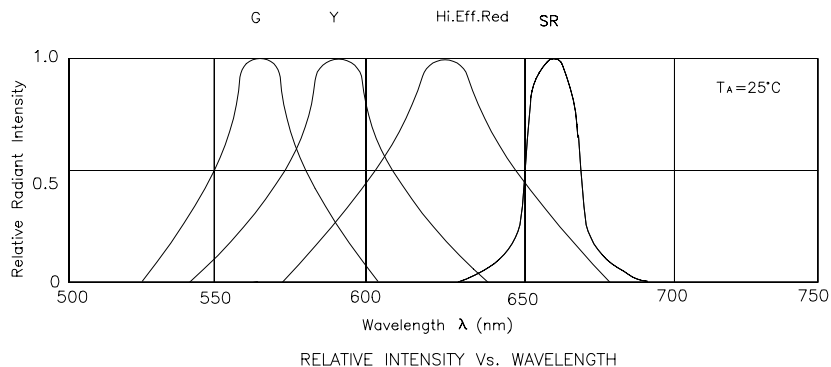

Kingbright

High Efficiency Red

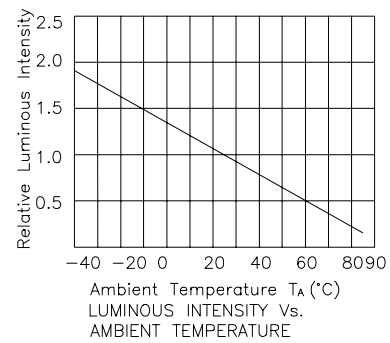
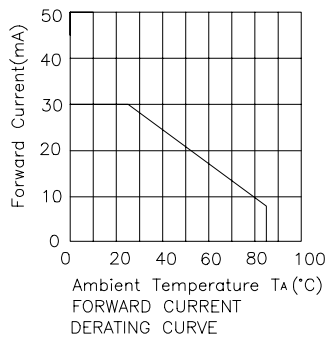
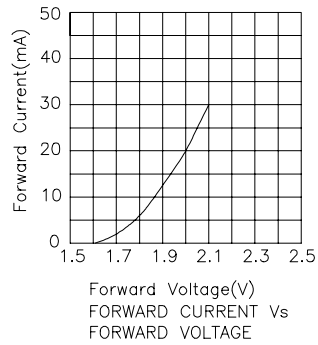

Green

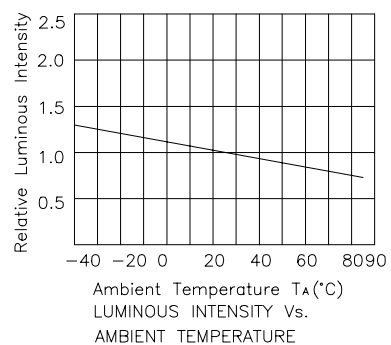
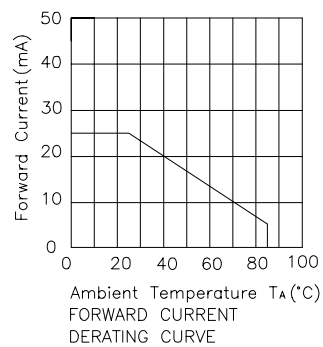
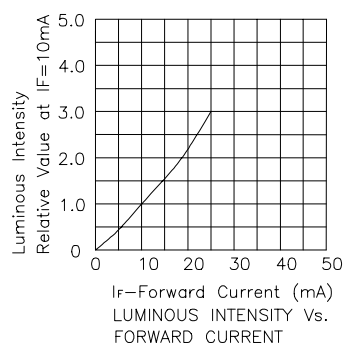
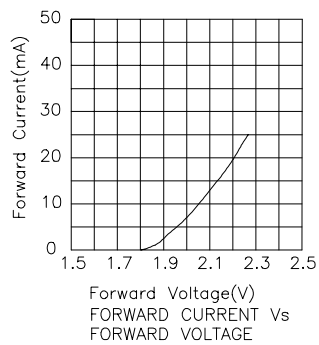

Kingbright

Yellow

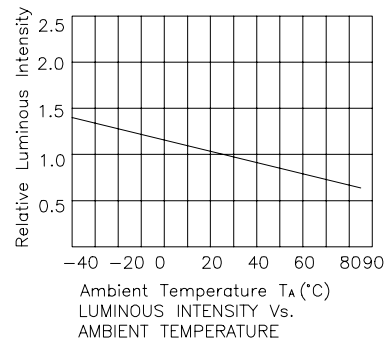
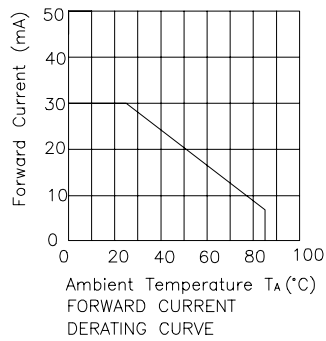
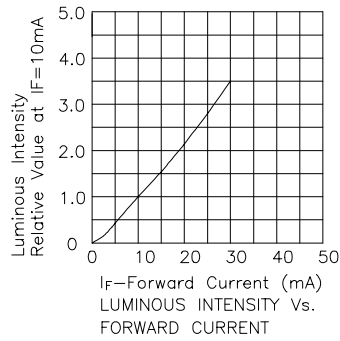
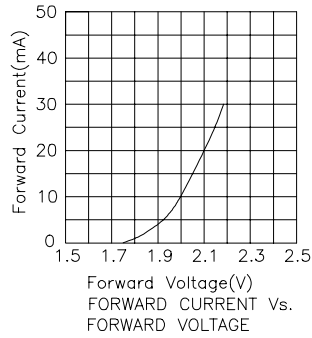

Super Bright Red

