



DELIC-LC
DELIC-PB
DSP Embedded Line and
Port Interface Controller
PEB 20570 Version 3.1
PEB 20571 Version 3.1

Wired
Communications



Edition 2003-07-31

**Published by Infineon Technologies AG,
St.-Martin-Strasse 53,
D-81541 München, Germany**

**© Infineon Technologies AG 8/4/03.
All Rights Reserved.**

Attention please!

The information herein is given to describe certain components and shall not be considered as warranted characteristics.

Terms of delivery and rights to technical change reserved.

We hereby disclaim any and all warranties, including but not limited to warranties of non-infringement, regarding circuits, descriptions and charts stated herein.

Infineon Technologies is an approved CECC manufacturer.

Information

For further information on technology, delivery terms and conditions and prices please contact your nearest Infineon Technologies Office in Germany or our Infineon Technologies Representatives worldwide (see address list).

Warnings

Due to technical requirements components may contain dangerous substances. For information on the types in question please contact your nearest Infineon Technologies Office.

Infineon Technologies Components may only be used in life-support devices or systems with the express written approval of Infineon Technologies, if a failure of such components can reasonably be expected to cause the failure of that life-support device or system, or to affect the safety or effectiveness of that device or system. Life support devices or systems are intended to be implanted in the human body, or to support and/or maintain and sustain and/or protect human life. If they fail, it is reasonable to assume that the health of the user or other persons may be endangered.

DELIC-LC

DELIC-PB

**DSP Embedded Line and
Port Interface Controller**

PEB 20570 Version 3.1

PEB 20571 Version 3.1

**Wired
Communications**



Table of Contents		Page
1	Introduction	2
1.1	DELIC-LC Key Features	4
1.2	DELIC-PB Key Features	4
1.3	Logic Symbol	6
1.4	Typical Applications	7
1.4.1	Applications for DELIC-LC	7
1.4.2	Applications for DELIC-PB	8
2	Pin Description	10
2.1	Pin Diagram DELIC-LC	10
2.2	Pin Diagram DELIC-PB	11
2.3	Pin Definitions and Functions for DELIC-LC	12
2.4	Pin Definitions and Functions for DELIC-PB	24
2.5	Strap Pin Definitions	38
3	Interface Description	40
3.1	Overview of Interfaces	40
3.2	IOM-2000 Interface	41
3.2.1	Overview	41
3.2.2	IOM-2000 Frame Structure	42
3.2.2.1	Data Interface	42
3.2.2.2	Command and Status Interface	45
3.2.3	UPN State Machine	48
3.2.3.1	INFO Structure on the UPN Interface	48
3.2.3.2	UPN Mode State Diagram	50
3.2.4	S/T State Machine	54
3.2.4.1	LT-S Mode	55
3.2.4.2	LT-T Mode	58
3.3	IOM®-2 Interface	63
3.3.1	Signals / Channels	63
3.4	µP Interface	64
3.4.1	Intel/Infineon or Motorola Mode	64
3.4.2	De-Multiplexed or Multiplexed Mode	64
3.4.3	DMA or Non-DMA Mode	66
3.4.4	DELIC External Interrupts	66
3.5	JTAG Test Interface	67
3.5.1	Boundary Scan Test	67
3.5.2	TAP Controller	67
4	Functional Description	69
4.1	Functional Overview and Block Diagram	70
4.2	IOM-2000 Transceiver Unit (TRANSIU)	71
4.2.1	IOM-2000 Features	71
4.2.2	IOM-2000 Initialization	71

Table of Contents		Page
4.2.3	Initialization of the VIP	72
4.2.4	IOM-2000 Command and Status Interface	72
4.2.4.1	Initialization Mode Command Bits	72
4.2.4.2	Operational Mode Command/Status Bits	72
4.2.4.3	Command/Status Transmission	72
4.2.4.4	Command and Status format in the Data RAM	74
4.2.5	UPN Mode Frame Structure	76
4.2.6	UPN Interface	79
4.2.7	UPN Framing Bit Description	80
4.2.7.1	Framing Bit (LF-Bit)	80
4.2.7.2	Multiframing Bit (M-Bit)	80
4.2.7.3	DC-Balancing Bit	81
4.2.7.4	UPN Mode Data Format	81
4.2.7.5	UPN Scrambler/Descrambler	82
4.2.8	DECT Synchronization for UPN- Interface	82
4.2.9	S/T Interface Frame Structure	83
4.2.9.1	LT-S mode	86
4.2.9.2	LT-T Mode	88
4.2.10	S/T Mode Control and Framing Bits on IOM-2000	90
4.2.10.1	Framing Bit (F-Bit)	90
4.2.10.2	Multiframing Bits	90
4.2.10.3	Fa/N Bit	92
4.2.10.4	DC-Balancing Bit (L-Bit)	93
4.2.11	IOM-2000 Data Interface	93
4.2.11.1	S/T Mode Data Format	93
4.2.12	Test Loop	94
4.3	IOM-2 Unit	95
4.3.1	IOMU Features	95
4.3.2	IOMU Functional and Operational Description	96
4.3.2.1	Frame-Wise Buffer Swapping	96
4.3.2.2	DSP Inaccessible Buffer (I-buffer) Logical Structure	96
4.3.2.3	DSP Access to the D-Buffer	97
4.3.2.4	Circular Buffer Architecture	98
4.3.2.5	IOM-2 Interface Data Rate Modes	100
4.3.2.6	IOMU Serial Data Processing	101
4.3.2.7	IOMU Parallel Data Processing	101
4.3.2.8	IOM-2 Push-Pull and Open-Drain Modes	102
4.3.2.9	Support of DRDY Signal from QUAT-S	103
4.4	PCM Unit	104
4.4.1	PCMU Functional and Operational Description	105
4.4.1.1	Frame-Wise Buffer Swapping	105
4.4.1.2	DSP Inaccessible Buffer (I-buffer)	105

Table of Contents		Page
4.4.1.3	DSP Accessible Buffer (D-Buffer)	106
4.4.1.4	PCMU Interface Data Rate Modes	107
4.4.1.5	PCMU Serial Data Processing	108
4.4.1.6	PCMU Parallel Data Processing	108
4.4.1.7	PCMU Tri-state Control Logic	109
4.5	A-/μ-law Conversion Unit	111
4.6	HDLC Unit	113
4.6.1	HDLC Overview	113
4.6.2	HDLCU Operation	115
4.6.2.1	Initialization of the HDLCU	115
4.6.2.2	Transmitting a Message	115
4.6.2.3	Ending a Transmission	116
4.6.2.4	Aborting a Transmission	116
4.6.2.5	DSP Access to the HDLCU Buffers	116
4.6.3	Functionality	116
4.7	GHDLC Unit	119
4.7.1	GHDLC Overview	119
4.7.2	GHDLC General Modes of Operation	119
4.7.3	External Configuration and Handshaking in Bus Mode	120
4.7.3.1	External Tri-State in Point-to-Multi-Point Mode	120
4.7.3.2	Arbitration Between Several GHDLCs	120
4.7.4	GHDLC Memory Allocation	122
4.7.5	GHDLC Interrupts	124
4.7.6	Operational Description	124
4.7.6.1	GHDLC Initialization	124
4.7.7	GHDLC Protocol Features	125
4.7.8	GHDLC possible Data Rates for the DELIC-LC/PB	125
4.7.9	GHDLC Using external DMA Controller	126
4.8	DSP Control Unit	127
4.8.1	General	127
4.8.2	DSP Address Decoding	127
4.8.3	Interrupt Handling	127
4.8.4	DSP Run Time Statistics	128
4.8.5	Data Bus and Program Bus Arbitration	129
4.8.6	Boot Support	129
4.8.7	Reset Execution and Boot Strap Pin Setting	130
4.9	General Mailbox	131
4.9.1	Overview	131
4.9.2	μP Mailbox	131
4.9.3	OAK Mailbox	132
4.10	DMA Mailbox (DELIC-PB only)	133
4.10.1	DMA Handshake	136

Table of Contents		Page
4.10.1.1	Two-cycle DMA Transfer Mode	137
4.10.1.2	Fly-by Mode	137
4.10.2	PEC Mode.	137
4.10.3	Transmit DMA Mailbox	137
4.10.4	Receive DMA Mailbox	139
4.10.5	FIFO Access	141
4.11	Clock Generator	142
4.11.1	Overview	142
4.11.2	DSP Clock Selection	144
4.11.3	PCM Master/Slave Mode Clocks Selection	144
4.11.4	DELIC Clock System Synchronization	144
4.11.5	IOM-2 Clock Selection	144
4.11.6	IOM-2000 Clock Selection	145
4.11.7	REFCLK Configuration	145
4.11.8	GHDLC Clock Selection	145
5	DELIC Memory Structure	146
5.1	DSP Address Space	146
5.1.1	DSP Register Address Space	146
5.1.2	DSP Program Address Space	146
5.1.3	DSP Data Address Space	147
5.2	μP Address Space	150
6	Register Description	151
6.1	Register Map	151
6.2	Detailed Register Description	161
6.2.1	TRANSIU Register Description	161
6.2.1.1	TRANSIU IOM-2000 Configuration Register	161
6.2.1.2	TRANSIU Channel Configuration Registers	162
6.2.1.3	VIP Command Registers (VIPCMR0, VIPCMR1, VIPCMR2)	164
6.2.1.4	VIP Status Registers	167
6.2.1.5	TRANSIU Initialization Channel Command Register	168
6.2.1.6	TRANSIU Initialization Channel Status Register (TICSTR)	173
6.2.1.7	Up Test Loop Register	174
6.2.1.8	Scrambler Mode Register	175
6.2.1.9	Scrambler Status Register	176
6.2.2	IOMU Register Description	177
6.2.2.1	IOMU Control Register	177
6.2.2.2	IOMU Status Register	178
6.2.2.3	IOMU Tri-State Control Register	179
6.2.2.4	IOMU DRDY Register	181
6.2.2.5	IOMU Data Prefix Register	182
6.2.3	PCMU Register Description	183

Table of Contents		Page
6.2.3.1	PCMU Command Register	183
6.2.3.2	PCMU Status Register	184
6.2.3.3	PCMU Tri-state Control Registers	185
6.2.3.4	PCMU Data Prefix Register	187
6.2.4	A/ μ -law Unit Register Description	188
6.2.4.1	A/ μ -law Unit Control Register	188
6.2.4.2	A/ μ -law Input Register	189
6.2.4.3	A/ μ -law Output Register	190
6.2.5	HDLCU Registers Description	191
6.2.5.1	HDLCU Control Register	191
6.2.5.2	HDLCU Status Register	192
6.2.5.3	Channel Command Vector	193
6.2.5.4	Channel Status Vector	195
6.2.6	GHDLC Register Description	197
6.2.6.1	GHDLC Test/ Normal Mode Register	197
6.2.6.2	GHDLC Channel Mode Register	198
6.2.6.3	GHDLC Interrupt Register	199
6.2.6.4	GHDLC FSC Interrupt Control Register	200
6.2.6.5	GHDLC Receive Channel Status Registers 0..3	201
6.2.6.6	GHDLC Receive Data and Status	203
6.2.6.7	GHDLC Mode Registers	204
6.2.6.8	GHDLC Channel Transmit Command Registers	206
6.2.6.9	ASYNCR Control Register	207
6.2.6.10	LCLK0 Control Register	208
6.2.6.11	LCLK1 Control Register	209
6.2.6.12	LCLK2 Control Register	210
6.2.6.13	LCLK3 Control Register	211
6.2.6.14	Muxes Control Register	212
6.2.6.15	GHDLCU Frame Frequency	213
6.2.7	DCU Register Description	214
6.2.7.1	Interrupt Mask Register	214
6.2.7.2	Status Event Register	215
6.2.7.3	Statistics Counter Register	216
6.2.7.4	Statistics Register	217
6.2.8	μ P Configuration Registers	218
6.2.8.1	μ P Interface Configuration Register	218
6.2.8.2	Interrupt Vector Register	220
6.2.9	μ P Mailbox Registers Description	221
6.2.9.1	μ P Command Register	221
6.2.9.2	μ P Mailbox Busy Register	222
6.2.9.3	μ P Mailbox Generic Data Register	223
6.2.9.4	μ P Mailbox (General and DMA Mailbox) Data Registers	224

Table of Contents		Page
6.2.9.5	DSP Command Register	225
6.2.9.6	DSP Mailbox Busy Register	226
6.2.9.7	DSP Mailbox Generic Data Register	227
6.2.9.8	DSP Mailbox (General and DMA Mailbox) Data Registers	228
6.2.10	DMA Mailbox Registers Description	229
6.2.10.1	DMA Mailbox Transmit Counter Register	229
6.2.10.2	DMA Mailbox Receive Counter Register	230
6.2.10.3	DMA Mailbox Interrupt Status Register	231
6.2.11	Clock Generator Register Description	232
6.2.11.1	PDC Control Register	232
6.2.11.2	PFS Control Register	233
6.2.11.3	CLKOUT Control Register	234
6.2.11.4	DCXO Reference Clock Select Register	235
6.2.11.5	REFCLK Control Register	236
6.2.11.6	DCL_2000 Control Register	237
6.2.11.7	DCL Control Register	238
6.2.11.8	FSC Control Register	239
6.2.11.9	L1_CLK Control Register	240
6.2.11.10	PFS Sync Register	241
6.2.11.11	Real-time Counter Register	242
6.2.11.12	Strap Status Register	243
7	Package Outlines	244
8	Electrical Characteristics and Timing Diagrams	245
8.1	Absolute Maximum Ratings	245
8.2	Operating Range	246
8.3	DC Characteristics	247
8.4	Capacitances	248
8.5	Recommended 16.384 MHz Crystal Parameters	248
8.6	AC Characteristics	249
8.6.1	DMA Access Timing	249
8.6.1.1	DMA Access Timing In Motorola Mode	249
8.6.1.2	DMA Access Timing In Intel/Infineon Mode	252
8.6.2	mP Access Timing	255
8.6.2.1	mP Access Timing in Motorola mode	255
8.6.2.2	mP Access Timing in Intel/Infineon Mode	257
8.6.3	Interrupt Acknowledge Cycle Timing	260
8.6.4	IOM-2 Interface Timing	262
8.6.5	PCM Interface Timing	266
8.6.6	IOM-2000 Interface Timing	270
8.6.7	LNC0..3 (Local Network Controller) Interface Timing	273
8.6.8	JTAG and Emulation Interface Timing	277

Table of Contents		Page
9	Application Hints	282
9.1	DELIC Connection to External Microprocessors	282
9.2	DELIC Worksheets	284
9.3	PCM Output Driver Anomaly	286
9.4	Reset Behaviour	287
10	Glossary	288
11	Index	290

List of Figures		Page
Figure 1	Block Diagram of the DELIC-LC	3
Figure 2	Block Diagram of the DELIC-PB	3
Figure 3	Logic Symbol	6
Figure 4	DELIC-LC in S/T and UPN Line Cards (up to 8 S/T and 16 UPN).	7
Figure 5	DELIC-LC/PB in Uk0 Line Card for 16 Subscribers.	8
Figure 6	DELIC-PB in Analog Line Card for 16 Subscribers	8
Figure 7	DELIC-PB in Small PBX	9
Figure 8	DELIC-PB in 4 Port SDSL Line Card	9
Figure 9	Pin Configuration DELIC-LC	10
Figure 10	Pin Configuration DELIC-PB	11
Figure 11	Overview of IOM-2000 Interface Structure (Example with One VIP) ..	41
Figure 12	IOM-2000 Data Sequence (1 VIP with 8 Channels)	43
Figure 13	IOM-2000 Data Order (3 VIPs with 24 Channels)	44
Figure 14	IOM-2000 CMD/STAT Handling (1 VIP with 8 Channels)	45
Figure 15	IOM-2000 Command/Status Sequence (3 VIPs with 24 Channels) ..	45
Figure 16	UPN State Diagram	50
Figure 17	State Diagram of LT-S Mode	56
Figure 18	LT-T Mode State Diagram (Conditional and Unconditional States) ...	60
Figure 19	IOM [®] -2 Interface in Digital Line Card Mode	63
Figure 20	DELIC in Multiplexed and in De-Multiplexed Bus Mode	65
Figure 21	Block Diagram	70
Figure 22	U _{PN} Interface Frame Structure	77
Figure 23	AMI Coding on the Up Interface.	78
Figure 24	Handling of UPN Frame (one Channel)	79
Figure 25	S/T Interface Line Code (without code violation)	83
Figure 26	Frame Structure at Reference Points S and T (ITU I.430).	84
Figure 27	Reference Clock Selection for Cascaded VIPs on IOM-2000	85
Figure 28	Handling of So Frame in LT-S Mode (One Channel)	86
Figure 29	D-Echo Bit Generation	87
Figure 30	Handling of So Frame in LT-T Mode (One Channel)	88
Figure 31	Collision Detection in the LT-T Mode	90
Figure 32	S/Q Channel Assignment	91
Figure 33	IOMU Integration in DELIC	96
Figure 34	IOMU Frame-Wise Circular-Buffer Architecture	98
Figure 35	The Circular-Buffer During two Consecutive Frames	99
Figure 36	IOM-2 Interface Timing in Single/Double Clock Mode	101
Figure 37	IOM-2 Interface Open-Drain Mode	102
Figure 38	IOM-2 Interface Push-Pull Mode	102
Figure 39	DRDY Signal Behavior	103
Figure 40	DRDY Sampling Timing	103
Figure 41	PCMU Integration in DELIC	105
Figure 42	IOM-2 Interface Timing in Single/Double Clock Mode	108

List of Figures	Page
Figure 43	A/ μ -law Unit Integration 111
Figure 44	HDLCU General Block Diagram 114
Figure 45	HDLC Data Flow in Receive Direction 117
Figure 46	Data Processing in the GHDL 119
Figure 47	GHDL Interface Lines 120
Figure 48	Point-to-Multi Point Bus Structure 122
Figure 49	GHDL Receive and Transmit Buffer Structure 124
Figure 50	Interframe Time Fill with shared Zero 125
Figure 51	Statistics Registers 128
Figure 52	Two-cycle DMA Transfer Mode for Receive Direction 134
Figure 53	Single cycle DMA transfer mode for Receive Data 135
Figure 54	Single cycle DMA transfer mode for Transmit Data 136
Figure 55	Timing in two-cycle DMA Mode for Transmit Direction and Infineon/ Intel Bus Type 138
Figure 56	Timing in two-cycle DMA Mode for Receive Direction and Infineon/ Intel Bus Type 140
Figure 57	DELIC Clock Generator 143
Figure 58	TRANSIU Buffer Addresses 149
Figure 59	DMA Write-Transaction Timing in Motorola Mode 251
Figure 60	DMA Read-Transaction Timing in Motorola Mode 252
Figure 61	DMA Write-Transaction Timing in Intel/Infineon Mode 254
Figure 62	DMA Read-Transaction Timing in Intel/Infineon Mode 254
Figure 63	Write Cycle Motorola Mode 256
Figure 64	Read Cycle Motorola Mode 257
Figure 65	Write Cycle Intel/Infineon Demultiplexed Mode 258
Figure 66	Read Cycle Intel/Infineon Demultiplexed Mode 258
Figure 67	Write Cycle Intel/Infineon Multiplexed Mode 259
Figure 68	Read Cycle in Intel/Infineon Multiplexed Mode 260
Figure 69	Interrupt Acknowledge Cycle Timing in Motorola Mode 261
Figure 70	Interrupt Acknowledge Cycle Timing in Intel/Infineon Mode 261
Figure 71	IREQ Deactivation Timing 262
Figure 72	IOM-2 Interface Timing 263
Figure 73	DRDY Timing 263
Figure 74	DCL Timing IOM-2 264
Figure 75	FSC Timing IOM-2 265
Figure 76	PFS Timing in Slave Mode (Input PCM Clocks) 267
Figure 77	PFS Timing in Master Mode 267
Figure 78	PFS Interface Timing 268
Figure 79	PDC Parameters 269
Figure 80	PDC Timing in Input Mode 269
Figure 81	IOM-2000 Interface Timing 271
Figure 82	FSC Timing IOM-2000 272

Figure 83	LNC0..3 (Local Network Controller) Interface Timing	274
Figure 84	LCLK0..3 Timing in Output Mode.	275
Figure 85	LCLK0..3 Timing in Input Mode	276
Figure 86	Test-Interface (Boundary Scan) Timing	278
Figure 87	Reset Indication Timing	279
Figure 88	CLOCKOUT Timing	279
Figure 89	L1_CLK Timing	280
Figure 90	XCLK Timing	280
Figure 91	REFCLK Timing	281
Figure 92	DELIC Connection to Intel 80386EX (Demuxed Configuration)	282
Figure 93	DELIC Connection to Infineon C165 (Demuxed Configuration).	283
Figure 94	DELIC-LC PCM Unit Mode 0 (4 Ports with 2 MBit/s).	284
Figure 95	Command/ Indication Handshake of General Mailbox.	285
Figure 96	Behavior of Output Driver if Last Bit is '1'	286
Figure 97	Behavior of Output Driver if Last Bit is '0'	286
Figure 98	Guaranteed Reset Behaviour	287

List of Tables		Page
Table 1	IOM®-2 Interface Pins (DELIC-LC)	13
Table 2	IOM-2000 Interface / LNC Port 1 (DELIC-LC)	14
Table 3	LNC Port 0 (DELIC-LC)	15
Table 4	Microprocessor Bus Interface Pins (DELIC-LC).	16
Table 5	PCM Interface Ports 0 ... 3 / LNC Ports 2 ... 3 (DELIC-LC)	18
Table 6	Clock Generator Pins (DELIC-LC) (additionally to IOM/PCM clocks) .	20
Table 7	Power Supply Pins (DELIC-LC)	21
Table 8	JTAG and Emulation Interface Pins (DELIC-LC)	22
Table 9	Test Interface Pins (DELIC-LC)	23
Table 10	IOM®-2 Interface Pins (DELIC-PB)	25
Table 11	IOM-2000 Interface / LNC Port 1 (DELIC-PB)	26
Table 12	LNC Port 0 (DELIC-PB)	27
Table 13	Microprocessor Bus Interface Pins (DELIC-PB)	28
Table 14	PCM Interface Ports 0 ... 3 / LNC Ports 2 ... 3 (DELIC-PB)	31
Table 15	Clock Generator Pins (DELIC-PB) (Additionally to IOM/PCM Clocks). .	34
Table 16	Power Supply Pins (DELIC-PB)	35
Table 17	JTAG and Emulation Interface Pins (DELIC-PB)	36
Table 18	Test Interface Pins (DELIC-PB)	37
Table 19	Strap Pins (Evaluated During Reset)	38
Table 20	Control Bits in S/T Mode on DR Line	42
Table 21	Control Bits in S/T Mode on DX Line	42
Table 22	INFO Structure on UPN Interface	48
Table 23	UPN State Machine Codes	52
Table 24	LT-S State Machine Codes	55
Table 25	LT-T Mode State Machine Codes (Conditional States)	58
Table 26	TAP Controller Instruction Codes	67
Table 27	Differences Between DELIC-LC and DELIC-PB	69
Table 28	D-Echo Bit	87
Table 29	S/T Mode Multiframe Bit Positions	92
Table 30	I-Buffer Logical Memory Mapping	97
Table 31	D-Buffer Address Space	97
Table 32	DCL Frequency in Different IOM-2 Modes.	100
Table 33	I-Buffer Logical Memory Mapping of Input Buffers.	106
Table 34	I-Buffer Logical Memory Mapping of Output Buffers	106
Table 35	DSP Access to D-Buffer Input Blocks	106
Table 36	DSP Access to D-Buffer Output Blocks	107
Table 37	PCM TSC in 4 x 32 TS Mode (4 x 2 MBit/s)	109
Table 38	PCM TSC in 2 x 64 TS Mode (2 x 4MBit/s)	109
Table 39	PCM TSC in 1 x 128 TS (1 x 8 MBit/s) and 1 x 256 TS (1 x 16 MBit/s) (1st Half) Mode 110	
Table 40	PCM TSC in 1 x 256 TS (1 x 16 MBit/s) (2nd Half) Mode	110
Table 41	GHDLCU Receive Buffer Configuration.	123

List of Tables		Page
Table 42	Interrupt Map	127
Table 43	Overview of Clock Signals	142
Table 44	DSP Registers Address Space	146
Table 45	DSP Program Address Space	146
Table 46	Occupied DSP Data Address Space	147
Table 47	OAK Memory Mapped Registers Address Space	148
Table 48	µP Address Space Table	150
Table 49	TRANSIU Register Map	151
Table 50	Scrambler Register Map	152
Table 51	IOMU Register Map	152
Table 52	PCMU Register Map	152
Table 53	A-/µ-Law Unit Register Map	153
Table 54	HDLCU Register Map	154
Table 55	GHDLC Register Map	154
Table 56	DCU Register Map	155
Table 57	µP Configuration Register Map	155
Table 58	General Mailbox Register Map	156
Table 59	DMA Mailbox Register Map	158
Table 60	Clock Generator Register Map	160
Table 61	Available ISDN Modes for Each VIP Channel	162
Table 62	Tristate Control Assignment for IOM-2 Time Slots.	180
Table 63	R/W Behavior During DMA Transactions in Normal and in Fly-By Mode	249
Table 64	DMA Transaction timing in Motorola Mode	250
Table 65	R/W Behavior During DMA Transactions in Normal and in Fly-By Modes.	253
Table 66	DMA Transaction Timing in Intel/Infineon Mode	253
Table 67	Timing for Write Cycle in Motorola Mode	255
Table 68	Timing for Read Cycle In Motorola Mode	256
Table 69	Timing for Write Cycle in Intel/Infineon Demultiplexed Mode.	257
Table 70	Timing For Read Cycle in Intel/Infineon Demultiplexed Mode	258
Table 71	Timing for Write Cycle in Intel/Infineon Multiplexed Mode	259
Table 72	Timing For Read Cycle in Intel/Infineon Multiplexed Mode	260
Table 73	Interrupt Acknowledge Cycle Timing	261
Table 74	IOM-2 Interface Timing	262
Table 75	DCL (IOM-2 Data Clock) Timing	264
Table 76	FSC (IOM-2 and IOM-2000 Frame-Sync) Timing	264
Table 77	PCM Interface Timing	266
Table 78	PDC (PCM Data Clock) Timing in Master Mode (Output Mode)	268
Table 79	PDC Timing in Input Mode	269
Table 80	IOM-2000 Interface Timing	270
Table 81	DCL_2000 (IOM-2000 Data Clock) Timing	272

List of Tables		Page
Table 82	LNC0..3 Interface Timing	273
Table 83	LCLK0..3 Timing in Output Mode	275
Table 84	LCLK0..3 Timing in Input Mode	275
Table 85	CLK_DSP Input Clock Timing	276
Table 86	Test Interface Timing	277
Table 87	Reset and RESIND (Reset Indication) timing	278
Table 88	CLOCKOUT Timing	279
Table 89	L1_CLK Timing	279
Table 90	XCLK Timing	280
Table 91	REFCLK Timing	281

Preface

This document provides reference information on the DELIC-LC/-PB Version 3.1.

Organization of this Document

This Data Sheet is divided into 11 chapters and appendices. It is organized as follows:

- **Chapter 1 Introduction**
Gives a general description of the product and its family, lists the key features, and presents some typical applications.
- **Chapter 2 Pin Description**
Lists pin locations with associated signals, categorizes signals according to function, and describes signals.
- **Chapter 3 Interface Description**
Describes the DELIC external interfaces.
- **Chapter 4 Functional Description**
Describes the features of the main functional blocks.
- **Chapter 5 DELIC Memory Structure**
Contains the memory organisation of the OakDSPCore[®].
- **Chapter 6 Register Description**
Contains the detailed register description.
- **Chapter 7 Package Outlines**
- **Chapter 8 Electrical Characteristics and Timing Diagrams**
Contains the DC specification.
Contains the AC specification.
- **Chapter 9 Application Hints**
Provides e.g. a worksheet
- **Chapter 10 Glossary**
- **Chapter 11 Index**

Your Comments

We welcome your comments on this document as we are continuously aiming at improving our documentation. Please send your remarks and suggestions by e-mail to sc.docu_comments@infineon.com

Please provide in the subject of your e-mail:

device name (DELIC-LC/ -PB), device number (PEB 20570/PEB 20571), device version (Version 3.1), or and in the body of your e-mail:

document type (Data Sheet), issue date (2003-07-31) and document revision number (DS 2.1).

1 Introduction

The DELIC and VIP chipset realizes multiple ISDN S/T and U_{PN} interfaces together with controller functionality typically needed in PBX or Central Office systems. This functionality comprises voice channel handling, signaling control, layer-1 control, and even signal processing tasks.

Moreover it provides a programmable master/slave clock generator with 2 PLLs, an universal μP interface and a DMA interface.

The controller part, **DELIC**, is available in two different versions:

- **DELIC-LC (PEB 20570)** is a line card controller providing voice channel switching, multiple HDLC and layer-1 control for up to three VIPs (24 ISDN channels). Other transceiver ICs (32 analog or 16 digital channels) may additionally be connected via IOM-2/GCI interface.
- **DELIC-PB (PEB 20571)** additionally provides a programmable telecom DSP including program and data RAM. This DSP can be used for layer-1 control, protocol support and signal processing. The flexibility gained by the programmability allows Infineon to offer different application specific solutions with the same silicon just by software configuration.

A configuration tool assists the user in finding a valid system configuration. Even more customer specific DSP-routines can be integrated with the assistance of Infineon.

The transceiver part, **VIP**, is available in two different versions:

- **VIP PEB 20590** is the first (8 channel) ISDN transceiver that implements multiple U_{PN} and S/T interfaces within one device. The user can decide by programming in which mode a desired channel shall work.

A total of 8 channels are provided for layer-1 subscriber or trunk line characteristic. The VIP is programmed by the DELIC via the IOM-2000 interface. VIP's eight channels are programmable in the following maximum partitioning between U_{PN} and S/T channels:

	Max. number of U_{PN} and S/T Channels				
U_{PN}	8	7	6	5	4
S/T	0	1	2	3	4

- **VIP-8 PEB 20591** Additionally to the features of the VIP, the VIP-8 allows any combination of U_{PN} S/T interface (i.e. each of the 8 channels may be programmed to S/T or U_{PN} mode)

Block diagrams:

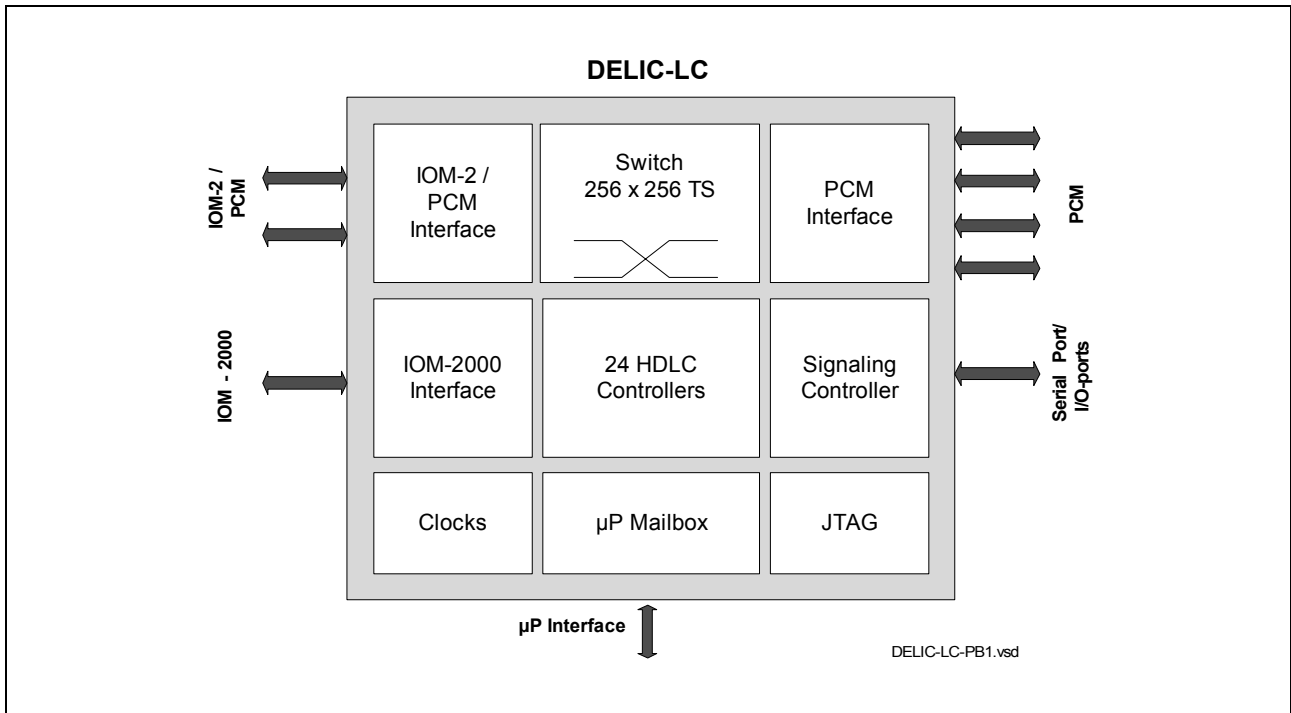

Figure 1 Block Diagram of the DELIC-LC

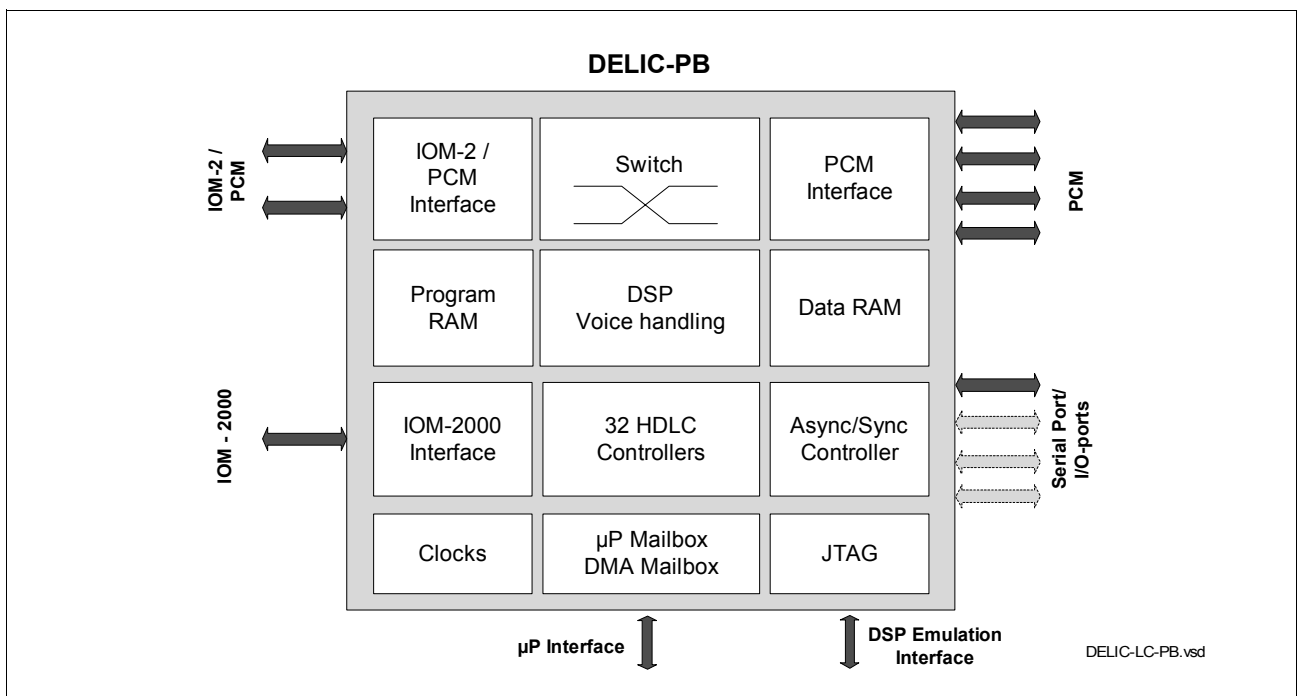

Figure 2 Block Diagram of the DELIC-PB



DSP Embedded Line and Port Interface Controller
DELIC-LC
DELIC-PB

PEB 20570
PEB 20571

Version 3.1

CMOS

1.1 DELIC-LC Key Features

DELIC-LC is optimized for line card applications:

- One IOM-2000 interface supporting three VIPs i.e. up to 24 ISDN channels
- Two IOM-2 (GCI) ports (configurable as PCM ports) supporting up to 16 ISDN channels or 32 analog subscribers
- Four PCM ports with up to 4 x 2.048 Mbit/s (4 x 32 TS) or 2 x 4.096 Mbit/s or 1 x 8.192 Mbit/s
- Switching matrix 256 x 256 TS (8-bit switching)
- 24 HDLC controllers assignable to any D- or B-channel (at 16 kbit/s or 64 kbit/s)
- Serial communication controller: high-speed signaling channel for 2.048 Mbit/s
- General purpose I/O ports
- Standard multiplexed and de-multiplexed μ P interface: Infineon, Intel, Motorola
- Programmable PLL based Master/Slave clock generator, providing all system clocks from a single 16.384 MHz crystal source
- JTAG compliant test interface
- single 3.3 V power supply, 5 V tolerant inputs

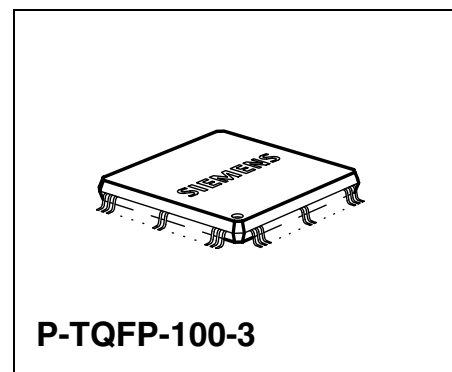

1.2 DELIC-PB Key Features

Compared to the DELIC-LC, having a fixed functionality, the DELIC-PB provides a high degree of flexibility (in terms of selected number of ports or channels).

Additionally it features computing power for typical DSP-oriented PBX tasks like conferencing, DTMF etc.

A Microsoft Windows based configuration tool, the Configurator, enables to generate an application specific functionality. Its features are mainly determined by the firmware of the integrated telecom DSP.

Type	Package
PEB 20571/ PEB 20570	P-TQFP-100-3

List of maximum available features:

- One IOM-2000 interface supporting up to three VIPs i.e. up to 24 ISDN channels
- Support of DASL mode
- Up to two IOM-2 (GCI) ports (also configurable as PCM ports) supporting up to 16 ISDN channels or 32 analog subscribers
- Up to four PCM ports with up to 4 x 2.048 Mbit/s (4 x 32 TS) or 2 x 4.096 Mbit/s or 1 x 8.192 Mbit/s
- Switching matrix 256 x 256 TS (switching of 4-/8- bit time slots)
- Up to 32 HDLC controllers assignable to any D- or B-channel (at 16 kbit/s or 64 kbit/s)
- Up to 4 serial communication controllers: one of them with up to 8.192 Mbit/s data rate
- General purpose I/O ports
- DECT synchronization support
- Standard multiplexed and de-multiplexed μ P interface: Infineon, Intel, Motorola
- Dedicated DMA support mailbox for 2 DMA-channels
- Integrated DSP core OAK+ (60 MIPS for layer 1 control, signalling and DSP-algorithms)
- 4 kWord on-chip program memory
- 2 kWord on-chip data memory
- 2 kWord ROM
- DSP work load measurement for run-time statistics, DSP alive indication
- On chip debugging unit
- Serial DSP program debugging interface connected via JTAG port
- A-/ μ -law conversion unit
- Programmable PLL based Master/Slave clock generator, providing all system clocks from a single 16.384 MHz crystal source
- JTAG compliant test interface
- single 3.3 V power supply, 5 V compatible inputs

*Note: As each feature consumes system resources (DSP-MIPS, memory, port pins), the maximum available number of supported interfaces or HDLC channels is limited by the totally available resources. A System Configurator tool (see **DELIC Software User's Manual**) helps to determine a valid configuration.*

1.3 Logic Symbol

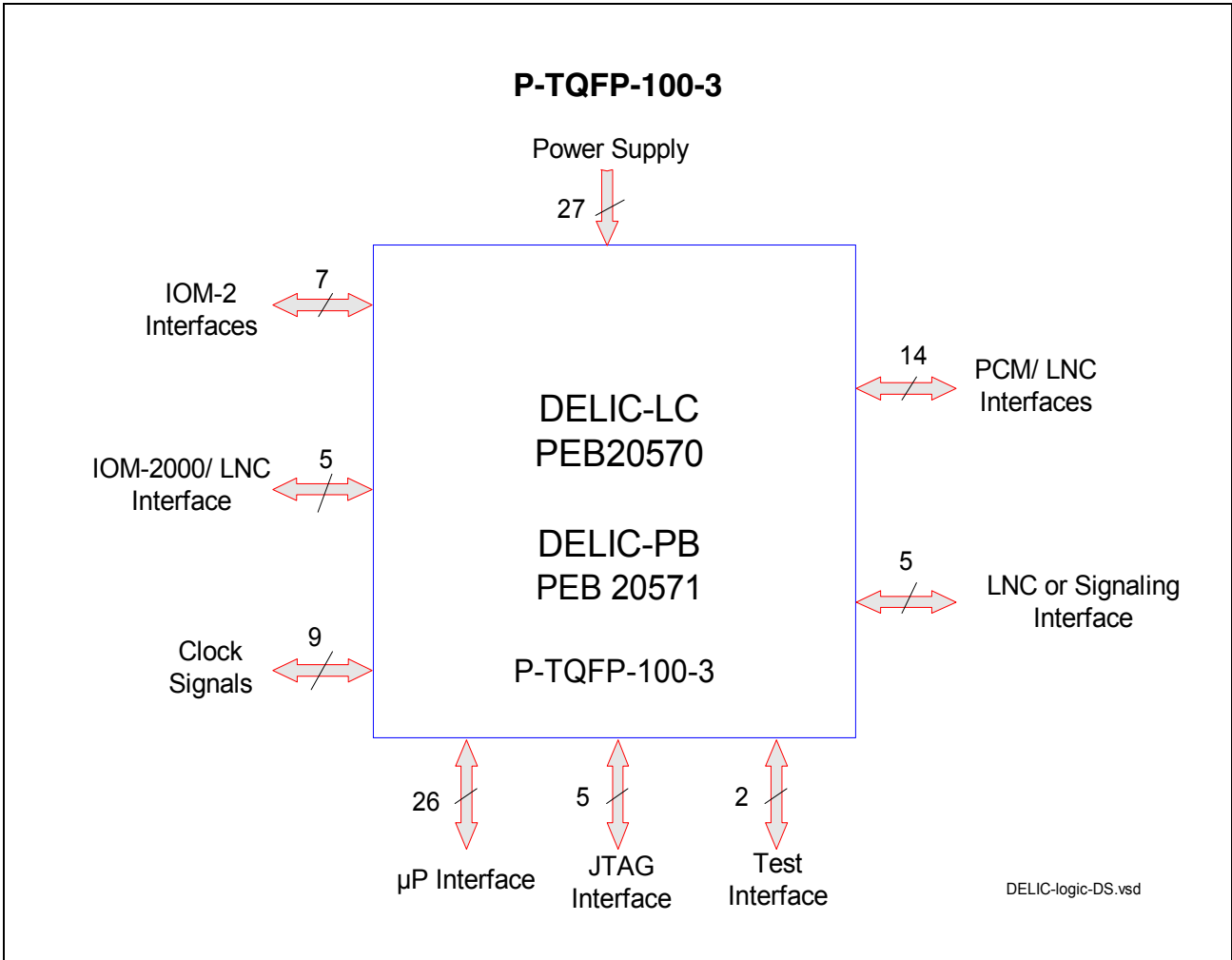

Figure 3 Logic Symbol

1.4 Typical Applications

1.4.1 Applications for DELIC-LC

The following two figures show example configurations of DELIC-LC Line card applications for different ISDN interface standards.

In **Figure 4**, three VIP transceiver ICs are connected to the DELIC-LC via the IOM-2000 interface, whereas in **Figure 5** and **Figure 6** an IOM-2 (GCI) interface is used to connect other ISDN transceivers.

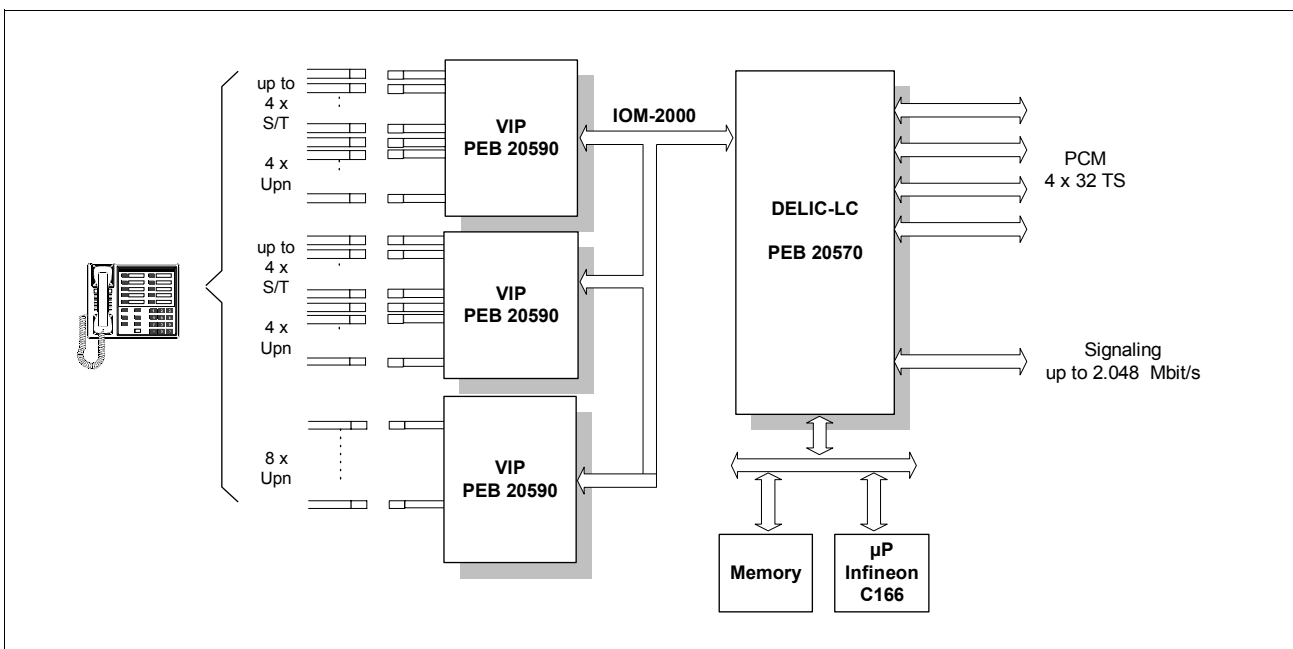

Figure 4 DELIC-LC in S/T and U_{PN} Line Cards (up to 8 S/T and 16 U_{PN})

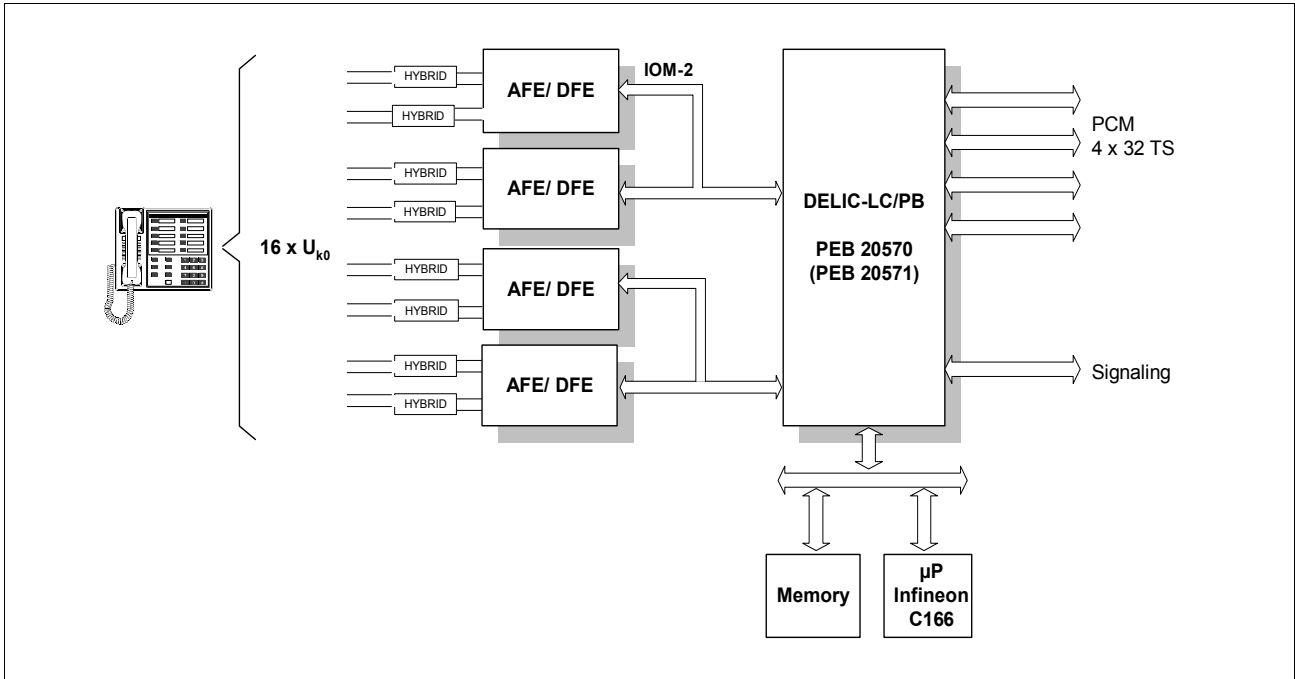

Figure 5 DELIC-LC/PB in Uko Line Card for 16 Subscribers

Note: In this application DELIC-PB is also meaningful.

1.4.2 Applications for DELIC-PB

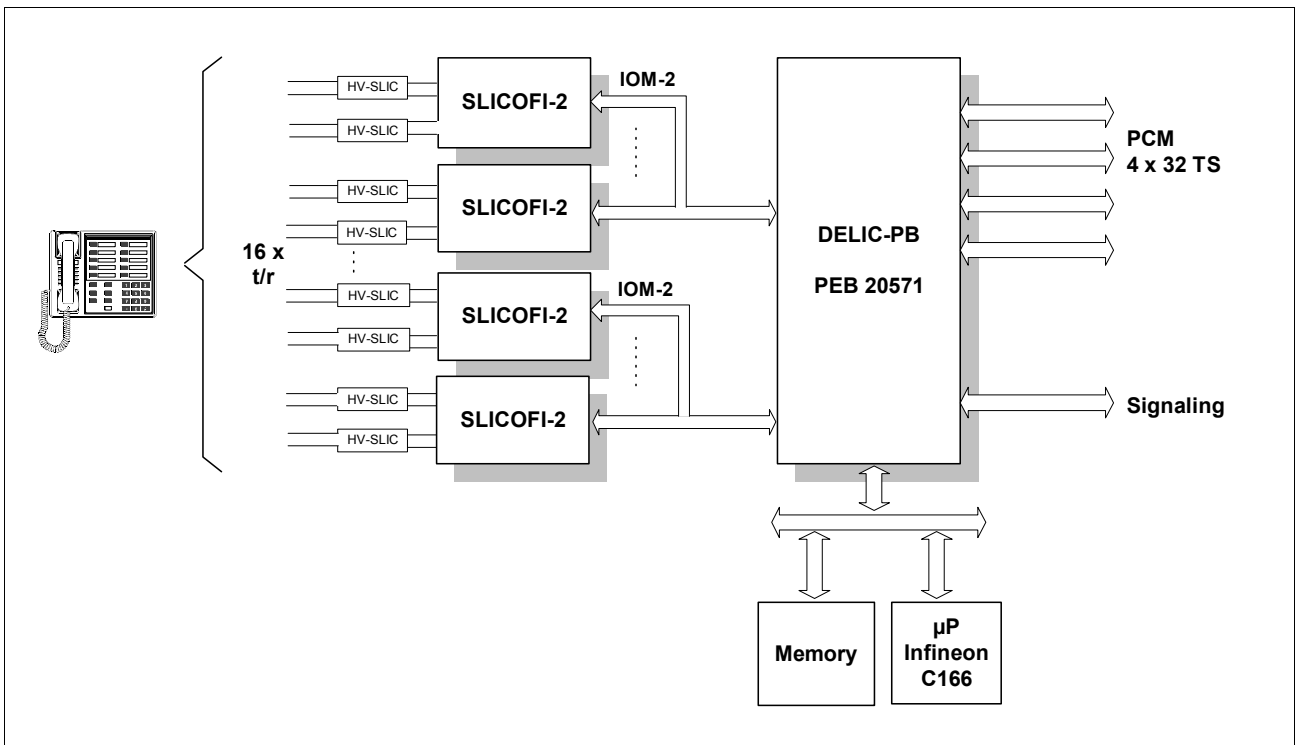

Figure 6 DELIC-PB in Analog Line Card for 16 Subscribers

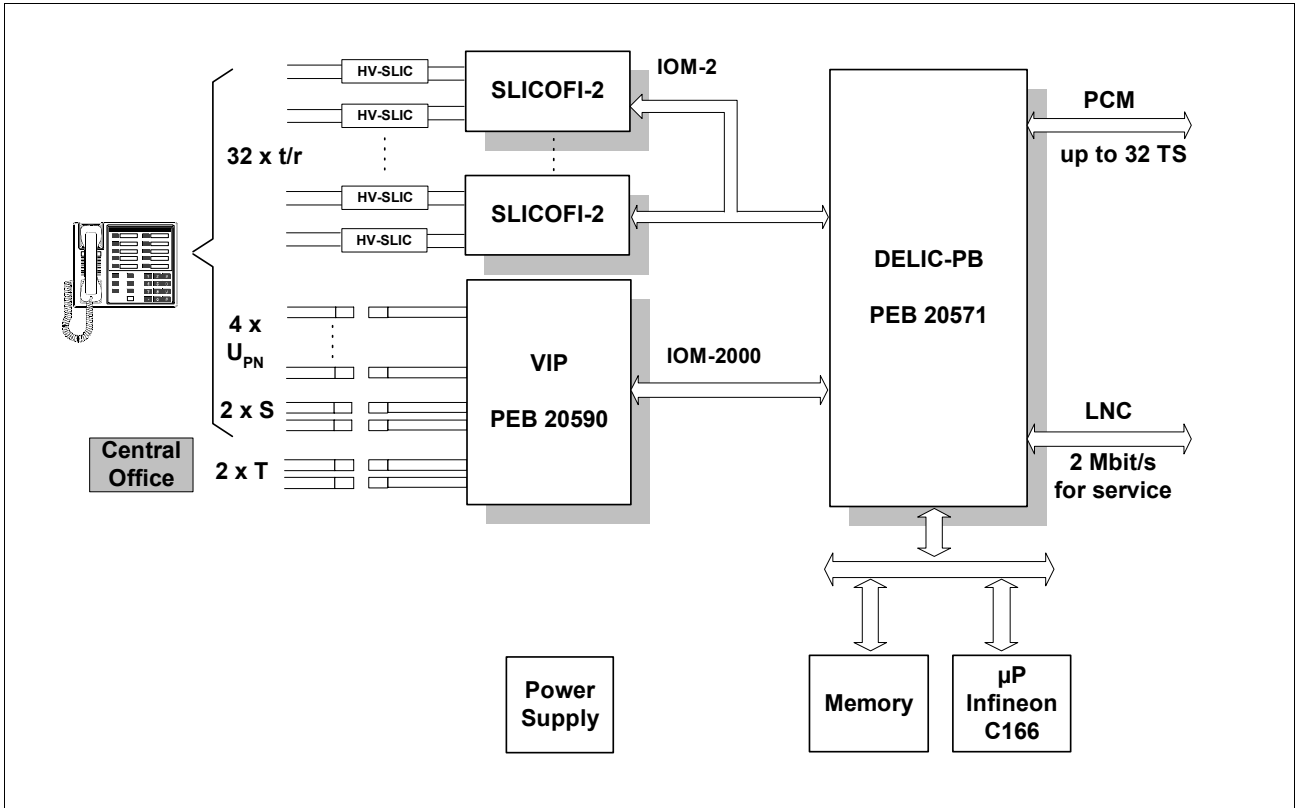

Figure 7 DELIC-PB in Small PBX

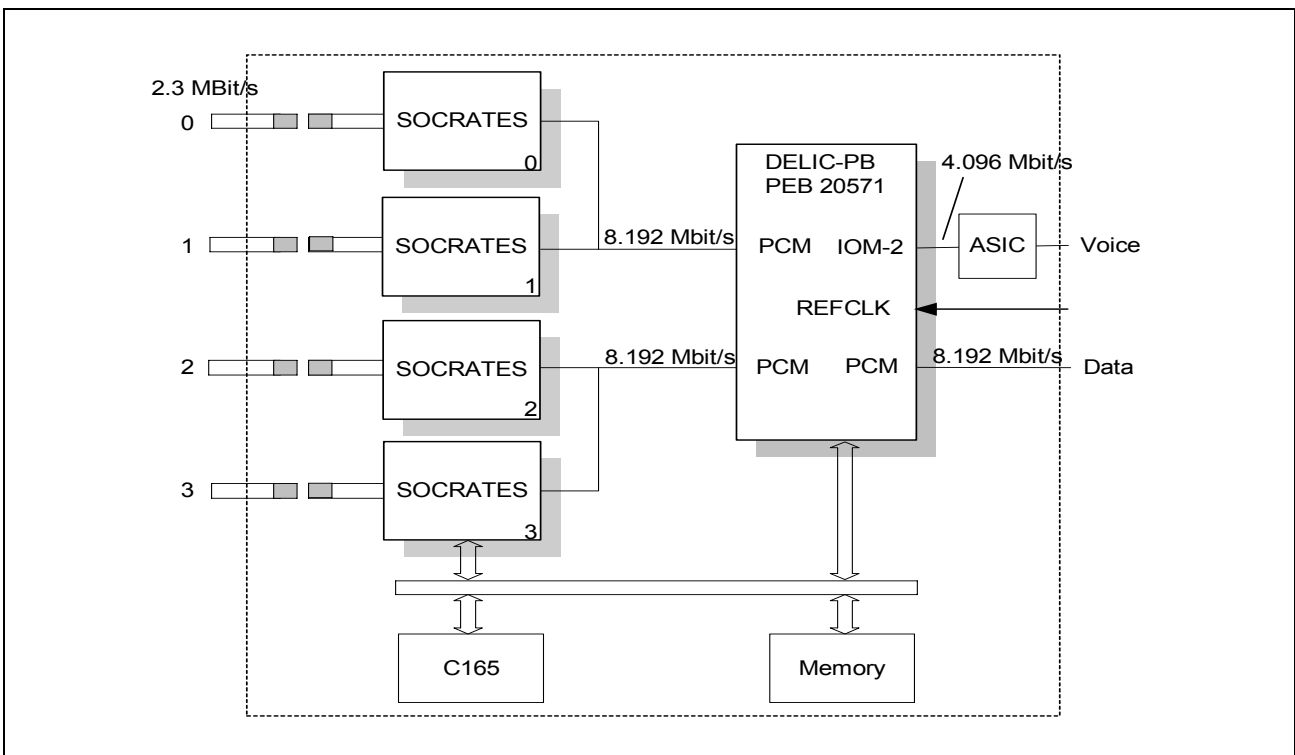

Figure 8 DELIC-PB in 4 Port SDSL Line Card

2 Pin Description

2.1 Pin Diagram DELIC-LC

(top view)

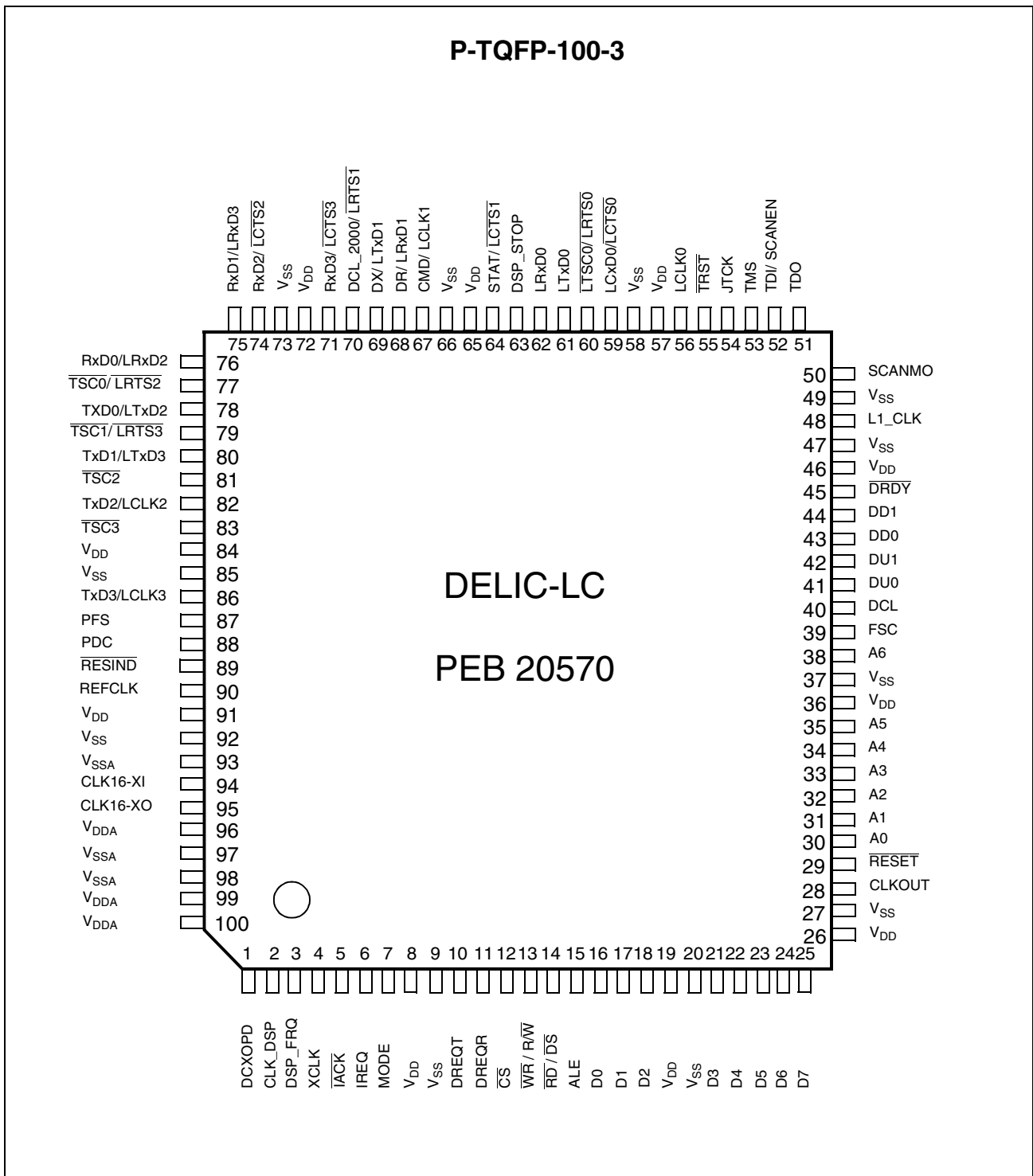

Figure 9 Pin Configuration DELIC-LC

2.2 Pin Diagram DELIC-PB

(top view)

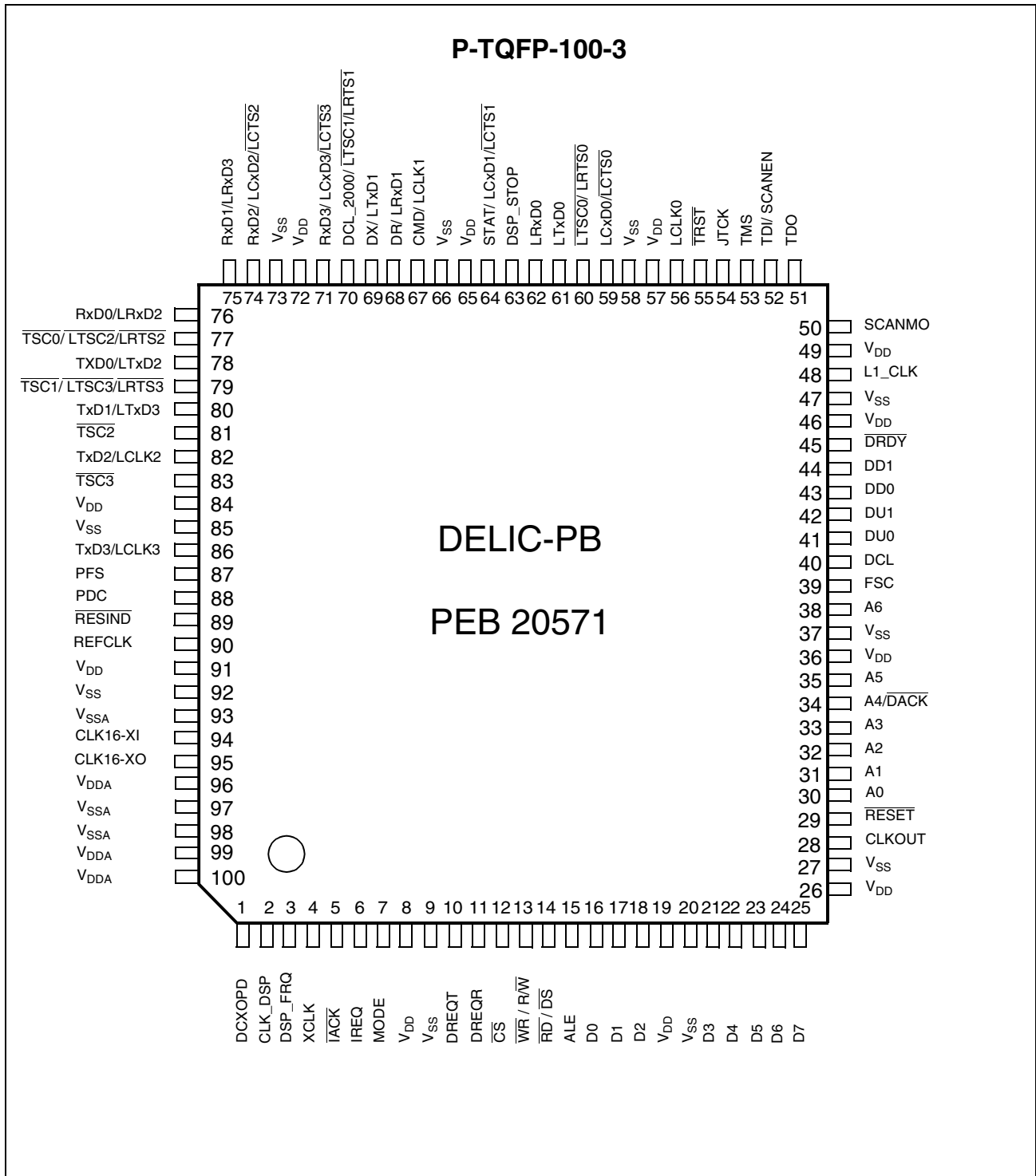

Figure 10 Pin Configuration DELIC-PB

2.3 Pin Definitions and Functions for DELIC-LC

Note: The column “During Reset” refers to the time period that starts with activation of \overline{RESET} input and ends with the deactivation of the \overline{RESIND} output. During this period, the DELIC strap pins (refer to [Table 19](#)) may be driven by external pull-down or pull-up resistors to define DELIC configuration. If external pull-down or pull-up resistors are not connected to the strap pins, the value of each strap pin during reset will be determined by an internal pull-up or pull-down resistor, according to the default strap value of each pin.

The user must ensure that connected circuits do not influence the sampling of the strap pins during reset.

The column “After Reset” describes the behavior of every pin, from the deactivation of the \overline{RESIND} output until the DELIC registers are programmed.

Note: In order to guarantee the reset behaviour of every pin please refer to the application hint “[Reset Behaviour](#)” on [Page 287](#).

Table 1 IOM[®]-2 Interface Pins (DELIC-LC)

Pin No.	Symbol	In (I) Out(O)	During Reset	After Reset	Function
39	FSC	O	O	O	Frame Synchronization Clock (8 kHz) Used for both the IOM-2 and the IOM-2000 interface
40	DCL	O	TEST-Strap (3), (pull-up), refer to Table 19	O	IOM-2 Data Clock 2.048 MHz or 4.096 MHz
43	DD0	O(OD)	High Z	High Z	Data Downstream IOM-2 Interface Channel0
44	DD1	O(OD)	High Z	High Z	Data Downstream IOM-2 Interface Channel1
41	DU0	I	I	I	Data Upstream IOM-2 Interface Channel 0
42	DU1	I	I	I	Data Upstream IOM-2 Interface Channel 1
45	DRDY	I	I	I	D- Channel Ready Stop/Go information for D-channel control on S/T interface in LT-T. Affects only IOM-2 port 0. $\overline{\text{DRDY}} = 1$ means GO $\overline{\text{DRDY}} = 0$ means STOP If DRDY is not used, this pin has to be connected to 'High' level

Table 2 IOM-2000 Interface / LNC Port 1 (DELIC-LC)

Pin No.	Symbol	In (I) Out (O)	During Reset	After Reset	Function
70	DCL_2000 / $\overline{\text{LRTS1}}$	O O	O	O	IOM-2000 Data Clock 3.072, 6.144 or 12.288 MHz 'request-to-send' functionality (Async mode)
69	DX / LTxD1	O O (OD)	High Z	High Z	Data Transmit Transmits IOM-2000 data to VIP LNC Transmit Serial Data Port 1 (Async mode).
68	DR / LRxD1	I I	I	I	Data Receive Receives IOM-2000 data from VIP LNC Receive Serial Data Port 1 (Async mode).
67	CMD / LCLK1	O I/O	High Z	High Z	IOM-2000 Command Transmits DELIC commands to VIP. LNC Clock Port 1. When configured as output may be driven at the following frequencies: 2.048 MHz, 4.096 MHz, 8.192 MHz, 16.384 MHz
64	STAT / $\overline{\text{LCTS1}}$	I I	I	I	IOM-2000 Status Receives status information from VIP. LNC1 Clear to Send 'clear-to-send' functionality (Async mode)

Table 3 LNC Port 0 (DELIC-LC)

Pin No.	Symbol	In (I) Out (O)	During Reset	After Reset	Function
62	LRxD0	I	I	I	LNC Receive Serial Data Port 0 (HDLC and Async mode).
61	LTxD0	O (OD)	High Z	High Z	LNC Transmit Serial Data Port 0 (HDLC and Async mode).
60	$\overline{\text{LTSC0}}$ / $\overline{\text{LRTS0}}$	O	$\overline{\text{PLL-}}$ Bypass” strap. Pull-up refer to Page 38	H	LNC0 Tristate Control / Request to Send 2 modes per S/W selectable: 1) TxD output is valid (HDLC mode). Supplies a control signal for an external driver. ('low' when the corresponding TxD-output is valid). 2) 'request-to-send' functionality (Async mode)
59	$\overline{\text{LCxD0}}$ / $\overline{\text{LCTS0}}$	I	I	I	LNC0 Collision Data / Clear to Send 2 modes per S/W selectable: 1) Collision Data (HDLC Mode). 2) 'clear-to-send' functionality (Async mode)
56	LCLK0	I/O	I	I	LNC Clock Port 0 When configured as output may be driven at the following frequencies: 2.048 MHz, 4.096 MHz, 8.192 MHz, 16.384 MHz

Table 4 Microprocessor Bus Interface Pins (DELIC-LC)

Pin No.	Symbol	In (I) Out (O)	During Reset	After Reset	Function
25 24 23 22 21 18 17 16	D7 D6 D5 D4 D3 D2 D1 D0	I/O The direction of these pins depends on the value of the following pins: \overline{CS} , $\overline{RD/DS}$, \overline{WR} / R/\overline{W} and MODE			Data Bus When operated in address/data multiplex mode, this bus is used as a multiplexed AD bus. The Address pins are externally connected to the AD bus.
38 35 34 33 32 31 30	A6 A5 A4 A3 A2 A1 A0	I	I	I	Address Bus (bits 6 ... 0) When operated in address/data multiplex mode, this bus is used as a multiplexed AD bus. The Data pins are externally connected to the AD bus.
11	DREQR	O	CLOCK MASTER Strap (pull-down), refer to Table 19	L	Strap pin
10	DREQT	O	EMUL- ATION BOOT Strap (pull-down), refer to Table 19	L	Strap pin
12	\overline{CS}	I	I	I	Chip Select A "low" on this line selects all registers for read/write operations.
13	\overline{WR} / R/\overline{W}	I	I	I	Write (Intel/Infineon Mode) Indicates a write access. Read/Write (Motorola Mode) Indicates the direction of the data transfer

Pin Description

Table 4 Microprocessor Bus Interface Pins (DELIC-LC) (cont'd)

Pin No.	Symbol	In (I) Out (O)	During Reset	After Reset	Function
14	$\overline{RD}/$ \overline{DS}	I	I	I	Read (Intel/Infineon Mode) Indicates a read access. Data Strobe (Motorola Mode) During a read cycle, \overline{DS} indicates that the DELIC should place valid data on the bus. During a write access, \overline{DS} indicates that valid data is on the bus.
15	ALE	I	I	I	Address Latch Enable Controls the on-chip address latch in multiplexed bus mode. While ALE is 'high', the latch is transparent. The falling edge latches the current address. ALE is also evaluated to determine the bus mode ('low'=multiplexed, 'high'=demultiplexed)
7	MODE	I	I	I	Bus Mode Selection Selects the μ P bus mode ('low'=Intel/Infineon, 'high'=Motorola)
6	IREQ	O (OD)	High Z (OD)	High Z (OD)	Interrupt Request is programmable to push/pull (active high or low) or open-drain. This signal is activated when the DELIC requests a μ P interrupt. When operated in open drain mode, multiple interrupt sources may be connected.
5	\overline{IACK}	I	I	I	Interrupt Acknowledge
29	\overline{RESET}	I	I	I	System Reset DELIC is forced to go into reset state.
89	\overline{RESIND}	O	O	O	Reset Indication Indicates that the DELIC is executing a reset. The DELIC remains in reset state for at least 500 μ s after the termination of the \overline{RESET} pulse.

Pin Description

Table 5 PCM Interface Ports 0 ... 3 / LNC Ports 2 ... 3 (DELIC-LC)

Pin No.	Symbol	In (I) Out (O)	During Reset	After Reset	Function
87	PFS	I/O	I	I	PCM Frame Synchronization Clock. 8 kHz/4 kHz when input or 8 kHz when output. <i>Note: When PFS is configured as 4 kHz input, PDC configuration is restricted to 2.048 MHz input.</i>
88	PDC	I/O	I	I	PCM Data Clock (input or output) 2.048 MHz, 4.096 MHz, 8.192 MHz, 16.384 MHz
76	RxD0 / LRxD2	I I	I	I	PCM Receive Data Port 0 LNC Receive Serial Data Port 2 (Async mode)
78	TxD0 / LTxD2	O O(OD)	High Z	High Z	PCM Transmit Data Port 0 LNC Transmit Serial Data Port 2 Async mode)
77	$\overline{\text{TSC0}}$ / $\overline{\text{LRTS2}}$	O O	$\overline{\text{Reset}}$ $\overline{\text{Counter}}$ $\overline{\text{Bypass}}$ strap pull-up refer to Page 38	H	PCM Tristate Control Port 0 Supplies a control signal for an external driver ('low' when the corresponding TxD-output is valid). LNC2 Request To Send 'request-to-send' functionality (Async mode)
74	RxD2 / $\overline{\text{LCTS2}}$	I I	I	I	PCM Receive Data Port 2 LNC2 'clear-to-send' functionality (Async mode)
82	TxD2 / LCLK2	O I/O	weak low	weak low	PCM Transmit Data Port 2 LNC External Clock Port 2 When configured as output may be driven at the following frequencies: 2.048 MHz, 4.096 MHz, 8.192 MHz, 16.384 MHz

Pin Description

Table 5 PCM Interface Ports 0 ... 3 / LNC Ports 2 ... 3 (DELIC-LC) (cont'd)

Pin No.	Symbol	In (I) Out (O)	During Reset	After Reset	Function
81	$\overline{\text{TSC2}}$	O	TEST(1) strap refer to Page 38	H	PCM Tristate Control Port 2 Supplies a control signal for an external driver ('low' when the corresponding TxD-output is valid).
75	RxD1 / LRxD3	I I	I I	I I	PCM Receive Data Port 1 LNC Receive Serial Data Port 3 (Async mode)
80	TxD1 / LTxD3	O O(OD)	High Z	High Z	PCM Transmit Data Port 1 LNC Transmit Serial Data Port 3 (Async mode)
79	$\overline{\text{TSC1}}$ / $\overline{\text{LRTS3}}$	O O	$\overline{\text{PLL}}$ $\overline{\text{Power-Down}}$ strap pull-up refer to Page 38	H	PCM Tristate Control Port 1 Supplies a control signal for an external driver ('low' when the corresponding TxD-output is valid). LNC3 Request to Send 'request-to-send' functionality (Async mode)
71	RxD3 / $\overline{\text{LCTS3}}$	I I	I I	I I	PCM Receive Data Port 3 LNC3 'clear-to-send' functionality (Async mode)
86	TxD3 / LCLK3	O I/O	weak low	weak low	PCM Transmit Data Port 3 LNC External Clock Port 3 When configured as output may be driven at the following frequencies: 2.048 MHz, 4.096 MHz, 8.192 MHz, 16.384 MHz
83	$\overline{\text{TSC3}}$	O	TEST(1) strap refer to Page 38	H	PCM Tristate Control Port 3 Supplies a control signal for an external driver ('low' when the corresponding TxD output is valid).

Pin Description

Table 6 Clock Generator Pins (DELIC-LC) (additionally to IOM/PCM clocks)

Pin No.	Symbol	In (I) Out (O)	During Reset	After Reset	Function
94	CLK16-XI	I	I	I	16.384 MHz External Crystal Input
95	CLK16-XO	O	O	O	16.384 MHz External Crystal Output
1	DCXOPD	I	I	I	DCXO Power Down and Bypass Activating this input powers down the on-chip DCXO PLL. The input CLK16-XI is used directly as the internal 16.384 MHz clock, and the oscillator and the shaper are bypassed. Required for testing; during normal operation this input should be permanently low ('0').
2	CLK_DSP	I	I	I	External DSP Clock Provides a DSP clock other than 61.44 MHz from an external oscillator.
3	DSP_FRQ	I	I	I	DSP Operational Frequency Selection (e.g. for test purpose) 0: The DSP is clocked internally at 61.44 MHz 1: The DSP clock is driven by the CLK_DSP input pin
48	L1_CLK	O	O	O	Layer-1 Clock 15.36 MHz or 7.68 MHz
28	CLKOUT	O	O	O	General Purpose Clock Output 2.048 MHz, 4.096 MHz, 8.192 MHz, 15.36 MHz or 16.384 MHz
4	XCLK	I	I	I	External Reference Clock Synchronization input from Layer-1 ICs (8 kHz, 512 kHz or 1.536 MHz) This pin is connected to the VIP's REFCLK output at 1.536 MHz.
90	REFCLK	I/O	I	I	Reference Clock Input: Synchronization of DELIC clock system Output: Used to drive a fraction of XCLK to the system clock master (8 kHz or 512 kHz programmable)

Table 7 Power Supply Pins (DELIC-LC)

Pin No.	Symbol	In (I) Out (O)	During Reset	After Reset	Function
8 19 26 36 46 57 65 72 84 91	V_{DD}	I	I	I	Power Supply 3.3 V Used for core logic and interfaces in pure 3.3 V environment
9 20 27 37 47 49 58 66 73 85 92	V_{SS}	I	I	I	Digital Ground (0 V)
96 99 100	V_{DDA}	I	I	I	Power Supply 3.3 V Analog Logic Used for DCXO and PLL
93 97 98	V_{SSA}	I	I	I	Analog Ground Used for DCXO and PLL

Table 8 JTAG and Emulation Interface Pins (DELIC-LC)

Pin No.	Symbol	In (I) Out (O)	During Reset	After Reset	Function
Used for boundary scan according to IEEE 1149.1					
54	JTCK	I	I	I	JTAG Test Clock Provides the clock for JTAG test logic. Used also for serial emulation interface.
53	TMS	I	I	I	Test Mode Select A '0' to '1' transition on this pin is required to step through the TAP controller state machine.
52	TDI / SCANEN	I	I	I	Test Data Input In the appropriate TAP controller state test data or a instruction is shifted in via this line. Used also for serial emulation interface. This pin must not be driven to low on the board during reset and operation to ensure functioning of DELIC SCAN Enable When both SCANMO and SCANEN are asserted, the full-scan tests of DELIC are activated. Not used during normal operation.
51	TDO	O	O	O	Test Data Output In the appropriate TAP controller state test data or an instruction is shifted out via this line. Used also for serial emulation interface.
55	$\overline{\text{TRST}}$	I	I	I	Test Reset Provides an asynchronous reset to the TAP controller state machine.
63	DSP_STOP	O	$\overline{\text{BOOT}}$ Strap (pull-down) refer to Table 19	O	DSP Stop Pin Stops external logic during breakpoints. Activated when a stop to the DSP is issued.

Table 9 Test Interface Pins (DELIC-LC)

Pin No.	Symbol	In (I) Out (O)	During Reset	After Reset	Function
50	SCANMO	I	I	I	Scan Mode If driven to '1' during device tests, TDI input is used as enable for full scan tests of the DELIC. SCANMO should be tied to GND during normal operation.

2.4 Pin Definitions and Functions for DELIC-PB

Note: The column “During Reset” refers to the time period that starts with activation of \overline{RESET} input and ends with the deactivation of the \overline{RESIND} output. During this period, the DELIC strap pins (refer to [Table 19](#)) may be driven by external pull-down or pull-up resistors to define DELIC configuration. If external pull-down or pull-up resistors are not connected to the strap pins, the value of each strap pin during reset will be determined by an internal pull-up or pull-down resistor, according to the default strap value of each pin.

The user must ensure that connected circuits do not influence the sampling of the strap pins during reset.

The column “After Reset” describes the behavior of every pin, from the deactivation of the \overline{RESIND} output until the DELIC registers are programmed.

Note: In order to guarantee the reset behaviour of every pin please refer to the application hint “[Reset Behaviour](#)” on [Page 287](#).

Table 10 IOM[®]-2 Interface Pins (DELIC-PB)

Pin No.	Symbol	In (I) Out(O)	During Reset	After Reset	Function
39	FSC	O	O	O	Frame Synchronization Clock (8 kHz) Used for both the IOM-2 and the IOM-2000 interface
40	DCL	O	TEST-Strap (3), (pull-up), refer to Table 19	O	IOM-2 Data Clock 2.048 MHz or 4.096 MHz
43	DD0	O(OD)	High Z	High Z	Data Downstream IOM-2 Interface Channel0
44	DD1	O(OD)	High Z	High Z	Data Downstream IOM-2 Interface Channel1
41	DU0	I	I	I	Data Upstream IOM-2 Interface Channel 0
42	DU1	I	I	I	Data Upstream IOM-2 Interface Channel 1
45	DRDY	I	I	I	D- Channel Ready Stop/Go information for D-channel control on S/T interface in LT-T. Affects only IOM-2 port 0. $\overline{\text{DRDY}} = 1$ means GO $\overline{\text{DRDY}} = 0$ means STOP If DRDY is not used, this pin has to be connected to 'High' level

Table 11 IOM-2000 Interface / LNC Port 1 (DELIC-PB)

Pin No.	Symbol	In (I) Out (O)	During Reset	After Reset	Function
70	DCL_2000 / $\overline{\text{LTSC1}}$ / $\overline{\text{LRTS1}}$	O O	O	O	IOM-2000 Data Clock 3.072, 6.144 or 12.288 MHz LNC1 Tristate Control /Request to Send 2 modes per S/W selectable: 1) TxD output is valid (HDLC mode). Supplies a control signal for an external driver. ('low' when the corresponding TxD-output is valid). 2) 'request-to-send' functionality (Async mode)
69	DX / LTxD1	O O (OD)	High Z	High Z	Data Transmit Transmits IOM-2000 data to VIP LNC Transmit Serial Data Port 1 (HDLC and Async mode).
68	DR / LRxD1	I I	I	I	Data Receive Receives IOM-2000 data from VIP LNC Receive Serial Data Port 1 (HDLC and Async mode).
67	CMD / LCLK1	O I/O	High Z	High Z	IOM-2000 Command Transmits DELIC commands to VIP. LNC Clock Port 1. When configured as output may be driven at the following frequencies: 2.048 MHz, 4.096 MHz, 8.192 MHz, 16.384 MHz
64	STAT / $\overline{\text{LCxD1}}$ / $\overline{\text{LCTS1}}$	I I	I	I	IOM-2000 Status Receives status information from VIP. LNC1 Collision Data / Clear to Send 1) Collision Data (HDLC Mode). 2) 'clear-to-send' functionality (Async mode)

Table 12 LNC Port 0 (DELIC-PB)

Pin No.	Symbol	In (I) Out (O)	During Reset	After Reset	Function
62	LRxD0	I	I	I	LNC Receive Serial Data Port 0 (HDLC and Async mode).
61	LTxD0	O (OD)	High Z	High Z	LNC Transmit Serial Data Port 0 (HDLC and Async mode).
60	$\overline{\text{LTSC0}}$ / $\overline{\text{LRTS0}}$	O	$\overline{\text{PLL-Bypass}}$ strap. pull-up refer to Page 38	H	LNC0 Tristate Control / Request to Send 2 modes per S/W selectable: 1) TxD output is valid (HDLC mode). Supplies a control signal for an external driver. ('low' when the corresponding TxD-output is valid). 2) 'request-to-send' functionality (Async mode)
59	LCxD0 / $\overline{\text{LCTS0}}$	I	I	I	LNC0 Collision Data / Clear to Send 2 modes per S/W selectable: 1) Collision Data (HDLC Mode). 2) 'clear-to-send' functionality (Async mode)
56	LCLK0	I/O	I	I	LNC Clock Port 0 When configured as output may be driven at the following frequencies: 2.048 MHz, 4.096 MHz, 8.192 MHz, 16.384 MHz

Table 13 Microprocessor Bus Interface Pins (DELIC-PB)

Pin No.	Symbol	In (I) Out (O)	During Reset	After Reset	Function
25 24 23 22 21 18 17 16	D7 D6 D5 D4 D3 D2 D1 D0	I/O The direction of these pins depends on the value of the following pins: \overline{CS} , $\overline{RD/DS}$, \overline{WR} / R/\overline{W} and MODE			Data Bus When operated in address/data multiplex mode, this bus is used as a multiplexed AD bus. The Address pins are externally connected to the AD bus.
38 35 33 32 31 30	A6 A5 A3 A2 A1 A0	I	I	I	Address Bus (bits 6 ... 0 except bit 4) When operated in address/data multiplex mode, this bus is used as a multiplexed AD bus. The Data pins are externally connected to the AD bus.
34	A4 $\overline{DACK/}$	I	I	I	Bit 4 of the address bus/ DMA Acknowledge In non-DMA mode $\overline{DACK/A4}$ input pin should be connected to A4 of the μP address-bus. In DMA mode A4 is internally connected to '0'.
11	DREQR	O	CLOCK MASTER Strap (pull-down), refer to Table 19	L	DMA Request for Receive Direction May be configured to active high or active low (the default is active high)
10	DREQT	O	EMULATION BOOT Strap (pull-down), refer to Table 19	L	DMA Request for Transmit Direction May be configured to active high or active low (the default is active high)

Pin Description

Table 13 Microprocessor Bus Interface Pins (DELIC-PB) (cont'd)

Pin No.	Symbol	In (I) Out (O)	During Reset	After Reset	Function
12	\overline{CS}	I	I	I	Chip Select A "low" on this line selects all registers for read/write operations.
13	$\overline{WR}/$ R/\overline{W}	I	I	I	Write (Intel/Infineon Mode) Indicates a write access. Read/Write (Motorola Mode) Indicates the direction of the data transfer
14	$\overline{RD}/$ \overline{DS}	I	I	I	Read (Intel/Infineon Mode) Indicates a read access. Data Strobe (Motorola Mode) During a read cycle, \overline{DS} indicates that the DELIC should place valid data on the bus. During a write access, \overline{DS} indicates that valid data is on the bus.
15	ALE	I	I	I	Address Latch Enable Controls the on-chip address latch in multiplexed bus mode. While ALE is 'high', the latch is transparent. The falling edge latches the current address. ALE is also evaluated to determine the bus mode ('low'=multiplexed, 'high'=demultiplexed)
7	MODE	I	I	I	Bus Mode Selection Selects the μP bus mode ('low'=Intel/Infineon, 'high'=Motorola)
6	IREQ	O (OD)	High Z (OD)	High Z (OD)	Interrupt Request is programmable to push/pull (active high or low) or open-drain. This signal is activated when the DELIC requests a μP interrupt. When operated in open drain mode, multiple interrupt sources may be connected.
5	\overline{IACK}	I	I	I	Interrupt Acknowledge

Pin Description

Table 13 Microprocessor Bus Interface Pins (DELIC-PB) (cont'd)

Pin No.	Symbol	In (I) Out (O)	During Reset	After Reset	Function
29	$\overline{\text{RESET}}$	I	I	I	System Reset DELIC is forced to go into reset state.
89	$\overline{\text{RESIND}}$	O	O	O	Reset Indication Indicates that the DELIC is executing a reset. The DELIC remains in reset state for at least 500 μs after the termination of the $\overline{\text{RESET}}$ pulse.

Pin Description

Table 14 PCM Interface Ports 0 ... 3 / LNC Ports 2 ... 3 (DELIC-PB)

Pin No.	Symbol	In (I) Out (O)	During Reset	After Reset	Function
87	PFS	I/O	I	I	PCM Frame Synchronization Clock. 8 kHz/4 kHz when input or 8 kHz when output. <i>Note: When PFS is configured as 4 kHz input, PDC configuration is restricted to 2.048 MHz input.</i>
88	PDC	I/O	I	I	PCM Data Clock (input or output) 2.048 MHz, 4.096 MHz, 8.192 MHz, 16.384 MHz
76	RxD0 / LRxD2	I I	I	I	PCM Receive Data Port 0 LNC Receive Serial Data Port 2 (HDLC and Async mode)
78	TxD0 / LTxD2	O O(OD)	High Z	High Z	PCM Transmit Data Port 0 LNC Transmit Serial Data Port 2 (HDLC and Async mode)
77	$\overline{\text{TSC0}}$ / $\overline{\text{LTSC2}}$ / $\overline{\text{LRTS2}}$	O O	$\overline{\text{Reset}}$ $\overline{\text{Counter}}$ $\overline{\text{Bypass}}$ strap pull-up refer to Page 38	H	PCM Tristate Control Port 0 Supplies a control signal for an external driver ('low' when the corresponding TxD-output is valid). LNC2 Tristate Control / Request To Send 2 modes per S/W selectable: 1) TxD output is valid (HDLC mode). Supplies a control signal for an external driver. ('low' when the corresponding TxD-output is valid). 2) 'request-to-send' functionality (Async mode)

Pin Description

Table 14 PCM Interface Ports 0 ... 3 / LNC Ports 2 ... 3 (DELIC-PB) (cont'd)

Pin No.	Symbol	In (I) Out (O)	During Reset	After Reset	Function
74	RxD2 / LCxD2/ LCTS2	I I	I	I	PCM Receive Data Port 2 LNC2 Collision Data 2 modes per S/W selectable: 1) Collision Data (In HDLC Mode). 2) 'clear-to-send' functionality (Async mode)
82	TxD2 / LCLK2	O I/O	weak low	weak low	PCM Transmit Data Port 2 LNC External Clock Port 2 When configured as output may be driven at the following frequencies: 2.048 MHz, 4.096 MHz, 8.192 MHz, 16.384 MHz
81	$\overline{\text{TSC2}}$	O	TEST(1) strap refer to Page 38	H	PCM Tristate Control Port 2 Supplies a control signal for an external driver ('low' when the corresponding TxD- output is valid).
75	RxD1 / LRxD3	I I	I	I	PCM Receive Data Port 1 LNC Receive Serial Data Port 3 (HDLC and Async mode)
80	TxD1 / LTxD3	O O(OD)	High Z	High Z	PCM Transmit Data Port 1 LNC Transmit Serial Data Port 3 (HDLC and Async mode)

Pin Description

Table 14 PCM Interface Ports 0 ... 3 / LNC Ports 2 ... 3 (DELIC-PB) (cont'd)

Pin No.	Symbol	In (I) Out (O)	During Reset	After Reset	Function
79	$\overline{\text{TSC1}}$ / $\overline{\text{LTSC3}}$ / $\overline{\text{LRTS3}}$	O	$\overline{\text{PLL}}$ $\overline{\text{Power-Down}}$ strap pull-up refer to Page 38	H	PCM Tristate Control Port 1 Supplies a control signal for an external driver ('low' when the corresponding TxD-output is valid). LNC3 Tristate Control / Request to Send 2 modes per S/W selectable: 1) TxD output is valid (HDLC mode). Supplies a control signal for an external driver. ('low' when the corresponding TxD-output is valid). 2) 'request-to-send' functionality (Async mode)
71	RxD3 / LCxD3/ LCTS3	I I	I	I	PCM Receive Data Port 3 LNC3 Collision Data 2 modes per S/W selectable: 1) Collision Data (HDLC Mode). 2) 'clear-to-send' functionality (Async mode)
86	TxD3 / LCLK3	O I/O	weak low	weak low	PCM Transmit Data Port 3 LNC External Clock Port 3 When configured as output may be driven at the following frequencies: 2.048 MHz, 4.096 MHz, 8.192 MHz, 16.384 MHz
83	$\overline{\text{TSC3}}$	O	TEST(1) strap refer to Page 38	H	PCM Tristate Control Port 3 Supplies a control signal for an external driver ('low' when the corresponding TxD output is valid).

Pin Description

Table 15 Clock Generator Pins (DELIC-PB) (Additionally to IOM/PCM Clocks)

Pin No.	Symbol	In (I) Out (O)	During Reset	After Reset	Function
94	CLK16-XI	I	I	I	16.384 MHz External Crystal Input
95	CLK16-XO	O	O	O	16.384 MHz External Crystal Output
1	DCXOPD	I	I	I	DCXO Power Down and Bypass Activating this input powers down the on-chip DCXO PLL. The input CLK16-XI is used directly as the internal 16.384 MHz clock, and the oscillator and the shaper are bypassed. Required for testing; during normal operation this input should be permanently low ('0').
2	CLK_DSP	I	I	I	External DSP Clock Provides a DSP clock other than 61.44 MHz from an external oscillator.
3	DSP_FRQ	I	I	I	DSP Operational Frequency Selection (e.g. for test purpose) 0: The DSP is clocked internally at 61.44 MHz 1: The DSP clock is driven by the CLK_DSP input pin
48	L1_CLK	O	O	O	Layer-1 Clock 15.36 MHz or 7.68 MHz
28	CLKOUT	O	O	O	General Purpose Clock Output 2.048 MHz, 4.096 MHz, 8.192 MHz, 15.36 MHz or 16.384 MHz
4	XCLK	I	I	I	External Reference Clock Synchronization input from Layer-1 ICs (8 kHz, 512 kHz or 1.536 MHz) This pin is connected to the VIP's REFCLK output at 1.536 MHz.
90	REFCLK	I/O	I	I	Reference Clock Input: Synchronization of DELIC clock system Output: Used to drive a fraction of XCLK to the system clock master (8 kHz or 512 kHz programmable)

Table 16 Power Supply Pins (DELIC-PB)

Pin No.	Symbol	In (I) Out (O)	During Reset	After Reset	Function
8 19 26 36 46 49 57 65 72 84 91	V_{DD}				Power Supply 3.3 V Used for core logic and interfaces in pure 3.3 V environment
9 20 27 37 47 58 66 73 85 92	V_{SS}				Digital Ground (0 V)
96 99 100	V_{DDA}				Power Supply 3.3 V Analog Logic Used for DCXO and PLL
93 97 98	V_{SSA}				Analog Ground Used for DCXO and PLL

Table 17 JTAG and Emulation Interface Pins (DELIC-PB)

Pin No.	Symbol	In (I) Out (O)	During Reset	After Reset	Function
Used for boundary scan according to IEEE 1149.1					
54	JTCK	I	I	I	JTAG Test Clock Provides the clock for JTAG test logic. Used also for serial emulation interface.
53	TMS	I	I	I	Test Mode Select A '0' to '1' transition on this pin is required to step through the TAP controller state machine.
52	TDI / SCANEN	I	I	I	Test Data Input In the appropriate TAP controller state test data or a instruction is shifted in via this line. Used also for serial emulation interface. This pin must not be driven to low on the board and should be connected to a pull-up during reset and operation to ensure functioning of DELIC SCAN Enable When both SCANMO and SCANEN are asserted, the full-scan tests of DELIC are activated. Not used during normal operation.
51	TDO	O	O	O	Test Data Output In the appropriate TAP controller state test data or an instruction is shifted out via this line. Used also for serial emulation interface.
55	$\overline{\text{TRST}}$	I	I	I	Test Reset Provides an asynchronous reset to the TAP controller state machine.
63	DSP_STOP	O	$\overline{\text{BOOT}}$ Strap (pull-down) refer to Table 19	O	DSP Stop Pin Stops external logic during breakpoints. Activated when a stop to the DSP is issued.

Table 18 Test Interface Pins (DELIC-PB)

Pin No.	Symbol	In (I) Out (O)	During Reset	After Reset	Function
50	SCANMO	I	I	I	Scan Mode If driven to '1' during device tests, TDI input is used as enable for full scan tests of the DELIC. SCANMO should be tied to GND during normal operation.

2.5 Strap Pin Definitions

Table 19 Strap Pins (Evaluated During Reset)

Pin No.	Strap Name	Strap Function	
DREQR (11)	CLOCK MASTER	0: (default)	Clock Slave PDC and PFS are used as inputs. PDC = 2.048 MHz PFS = 4 kHz
		1:	Clock Master PDC and PFS are used as outputs. PDC = 2.048 MHz PFS = 8 kHz
DSP_STOP (63)	BOOT	0: (default)	The DSP starts running from address FFFE _H , and executes the μ P boot routine.
		1:	The DSP starts running directly from address 0000 _H . The boot routine is not executed.
DCL (40): $\overline{\text{TSC3}}$ (83): $\overline{\text{TSC2}}$ (81)	TEST(2) TEST(1) TEST(0)	111: (default)	Regular Work Mode
		101	Test mode 1
		100	Test mode 2
		011	Test mode 3
		010	Test mode 4
		001	Test mode 5
		110	undefined
DREQT (10)	EMULATION BOOT	0: (default)	After reset the boot-routine loads the program RAM via the μ P-interface (via the general mail-box).
		1:	After reset the boot-routine loads the program RAM via the CDI mail-box (via the JTAG interface).

Table 19 Strap Pins (Evaluated During Reset) (cont'd)

LTSC (60)	PLL BYPASS	0:	DSP_CLK input pin (the DSP fall-back clock) is used as source for the 61 MHz clock division chain. (Only for testing).
		1: (default)	The PLL output is used as the source for the 61 MHz clock division chain.
TSC1 (79)	PLL POWER DOWN	0:	The PLL is powered-down. (for IDDQ tests)
		1:(default)	The PLL is on.
TSC0 (77)	RESET COUNTER BYPASS	0:	The reset-counter is bypassed, thus the internal reset is the filtered reset. The internal reset lasts 1-2 16 MHz cycles after a deactivation of $\overline{\text{RESET}}$.
		1: (default)	The internal reset lasts 4-5 8 kHz cycles (> 500 μs) after a deactivation of $\overline{\text{RESET}}$

Note: When the strap pins are not driven externally during reset, they are driven by internal pull-ups/pull-downs. To reduce power consumption, the internal pull-up/pull-down resistors are connected only during activated $\overline{\text{RESET}}$ input. To ensure the default value of the straps, the pins must not be driven during reset. In case of fixed external pull-up/pull-down, a pull-up/pull-down resistance of 10 K Ω +/-10% is recommended.

Note: Because of the internal pull-ups are too weak its recommended to connect any pin used as a strap during reset, to an external pull-up/ pull-down resistor, even if it's supposed to be driven to it's default strap-value.

3 Interface Description

3.1 Overview of Interfaces

The DELIC provides the following system interfaces:

IOM-2000 Interface

A new serial layer 1 interface driving up to three VIP/ VIP8 (Versatile ISDN Port, PEB 20590/ PEB 20591). Each VIP provides eight 2B+D ISDN channels, which can be programmed via IOM-2000 to S/T mode or U_{PN} mode.

IOM-2 (GCI) Interface

Two standard IOM-2 (GCI) ports with eight 2B+D ISDN channels each, at a data rate of up to 2 x 2.048 Mbit/s. They can be combined to a 4.096 Mbit/s highway.

PCM Interface

Four standard Master/Slave PCM interfaces with up to 32 time slots each, at a data rate of up to 4 x 2.048 Mbit/s. They can be combined to two 4.096 Mbit/s highways or one 8.192 Mbit/s highway. Additionally, 128 time slots of 256 time slots per 8 kHz frame can be transmitted at a rate of 16.384 Mbit/s.

Serial Communication Interface (GHDLIC)

An asynchronous serial port supporting HDLC formatted data frames at a data rate of up to 8.192 Mbit/s.

Microprocessor Interface

A standard 8-bit multiplexed/de-multiplexed μ P interface, compatible to Intel/Infineon (e.g. 80386EX, C166) and Motorola (e.g. 68340, 801) bus systems. It includes two separate mailboxes, one for normal data transfer, and one for fast DMA transfers.

JTAG Boundary Scan Test Interface

- DELIC provides a standard test interface according to IEEE 1149.1. The 4-bit TAP controller has an own reset input.
- The JTAG pins TDI, TDO and JTCK may also be used as interface for DSP emulation.

3.2 IOM-2000 Interface

3.2.1 Overview

The IOM-2000 interface represents a new concept for connecting ISDN layer-1 devices to the DELIC. The transceiver unit (TRANSIU) and the DSP perform the layer-1 protocol, which enables flexible and efficient operation of the transceiver IC (VIP/ VIP8).

VIP/ VIP8 supports two types of ISDN interfaces: 2-wire (ping-pong) U_{PN} interfaces and 4-wire S/T interfaces. For detailed description please refer to VIP/ VIP8 Data Sheet.

The IOM-2000 interface consists of the following signals:

- **Frame Synchronization:** IOM-2000 uses the same 8 kHz FSC as the IOM-2 ports.
- **Data Interface:** Data is transmitted via DX line from DELIC to VIP with DCL_2000 rising edge. Data is received via DR line from VIP to DELIC, sampled with DCL_2000 falling edge.
- **Command/Status Interface:** Configuration and control information of VIP's layer-1 transceivers is exchanged via CMD and STAT lines.
- **Data/Command Clock:** Data and commands for one VIP are transmitted at 3.072 MHz. When DELIC drives 2 or 3 VIPs, the transmission rate is increased.
- **Reference Clock:** In LT-T mode, the VIP provides a reference clock synchronized to the exchange. In LT-S or U_{PN} mode, DELIC is always the clock master to VIP.

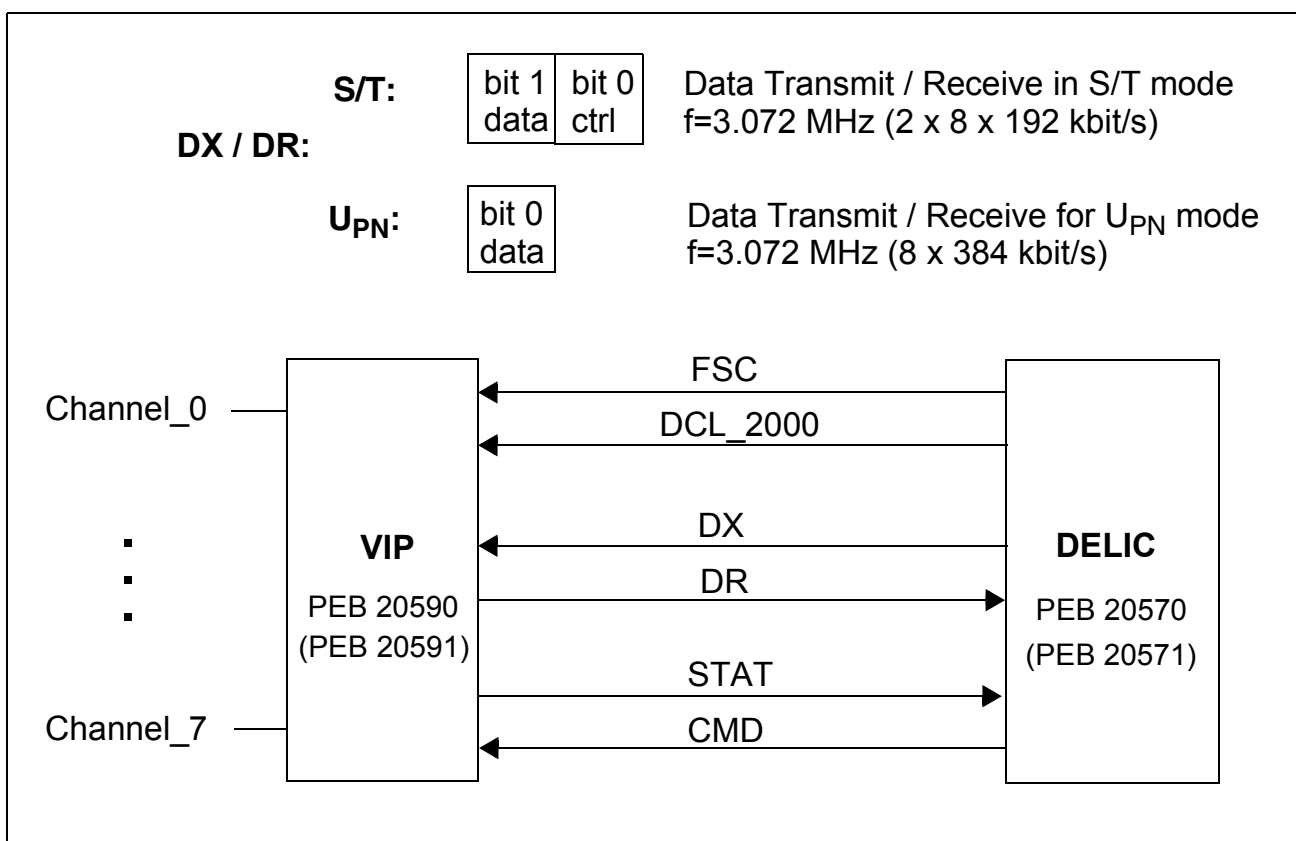

Figure 11 Overview of IOM-2000 Interface Structure (Example with One VIP)

3.2.2 IOM-2000 Frame Structure

3.2.2.1 Data Interface

On the ISDN line side of the VIP, data is ternary coded. Since the VIP contains logic to detect the level of the signal, only the data value is transferred via IOM-2000 to DELIC.

U_{PN} Mode

In U_{PN} mode, only data is sent via the IOM-2000 data interface.

S/T Mode

In S/T mode, data and control information is sent via IOM-2000 data interface. Every data bit has a control bit associated with it. Thus, for each S/T line signal, 2 bits are transferred via DX and DR. Bit0 is assigned to the user data, and bit1 carries control information.

Table 20 Control Bits in S/T Mode on DR Line

ctrl (bit1)	data (bit0)	Function
0	0	Logical '0' received on line interface
0	1	Logical '1' received on line interface
1	0	Received E-bit = inverted transmitted D-bit ($E=\bar{D}$) (LT-T only)
1	1	F-bit (Framing) received; indicates the start of the S frame

Table 21 Control Bits in S/T Mode on DX Line

ctrl (bit1)	data (bit0)	Function
0	0	Logical '0' transmitted on line interface
0	1	Logical '1' transmitted on line interface
1	0	not used
1	1	F-bit (Framing) transmitted; indicates the start of the S frame

Note: 'data' is always transmitted prior to 'ctrl' via DX/DR lines (refer to [Figure 12](#)).

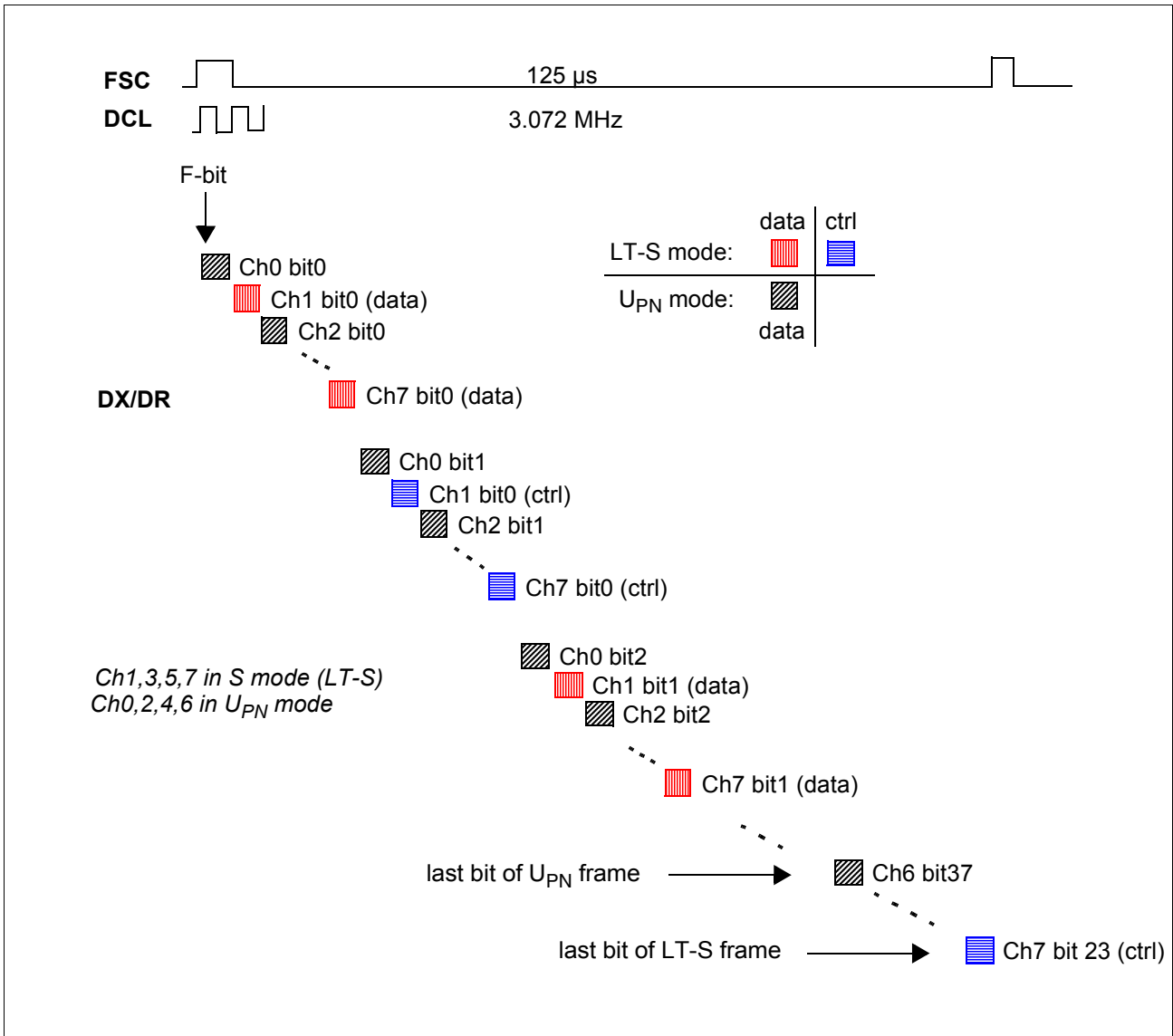

Figure 12 IOM-2000 Data Sequence (1 VIP with 8 Channels)

- Note:*
1. Data transfer on IOM-2000 interface always starts with the MSB (related to B channels), whereas CMD and STAT bits transfer always starts with LSB (bit 0) of any register
 2. All registers follow the Intel structure (LSB=2⁰, MSB=2³¹)
 3. Unused bits are don't care ('x')
 4. The order of reception or transmission of each VIP channel is always channel 0 to channel 7. A freely programmable channel assignment of multiple VIPs on IOM-2000 (e.g., ch0 of VIP_0, ch1 of VIP_0, ch0 of VIP_1, ch2 of VIP_0,...) is not possible.

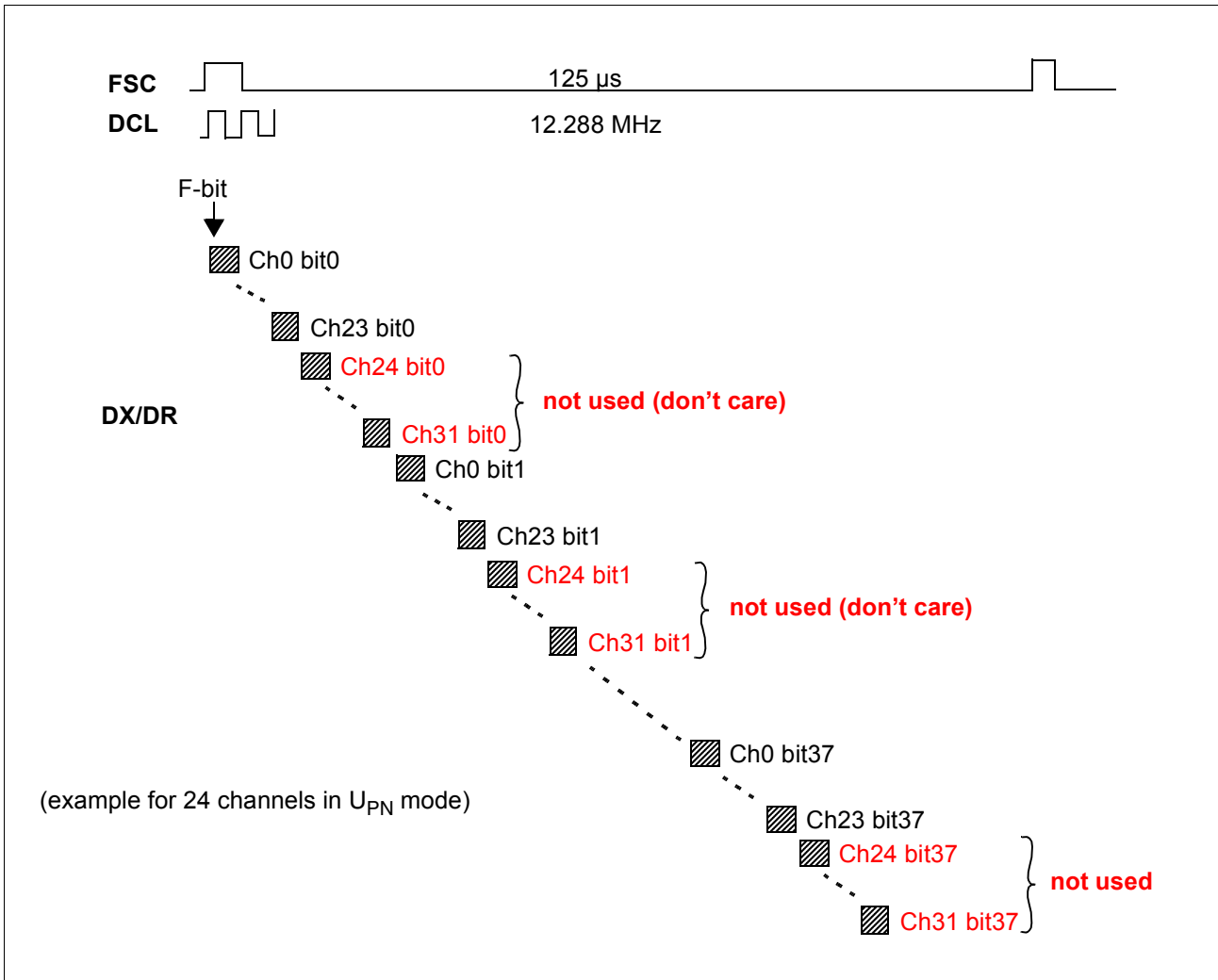

Figure 13 IOM-2000 Data Order (3 VIPs with 24 Channels)

Receive Data Channel Shift

In receive direction (DR), data of all IOM-2000 channels (ch0...7 if one VIP is used, ch0 ... ch23 if three VIPs are used) is shifted by 2 channels with respect to the transmitted data channels (DX), assuming a start of transmission of ch0 bit0 with the FSC signal. DELIC is transmitting ch0, while receiving ch2 via DR the same time, etc.

DX	ch0	ch1	ch2	ch3	ch4	ch5	ch6	ch7	ch0
DR	ch2	ch3	ch4	ch5	ch6	ch7	ch0	ch1	ch2

3.2.2.2 Command and Status Interface

The CMD and STAT lines are the configuration and control interface between DELIC and VIP. The bit streams are partitioned into 32-bit words carrying information *dedicated to the VIPs* (CMD_0 / STAT_0) followed by information *dedicated to the individual channels* of the same VIP (CMD_0_0 ... CMD_2_7 or STAT_0_0 ... STAT_2_7).

Note: As opposed to data, command and status bits are sent channel-wise, starting with channel_0. The transmission clock is the same as the DR/DX data clock.

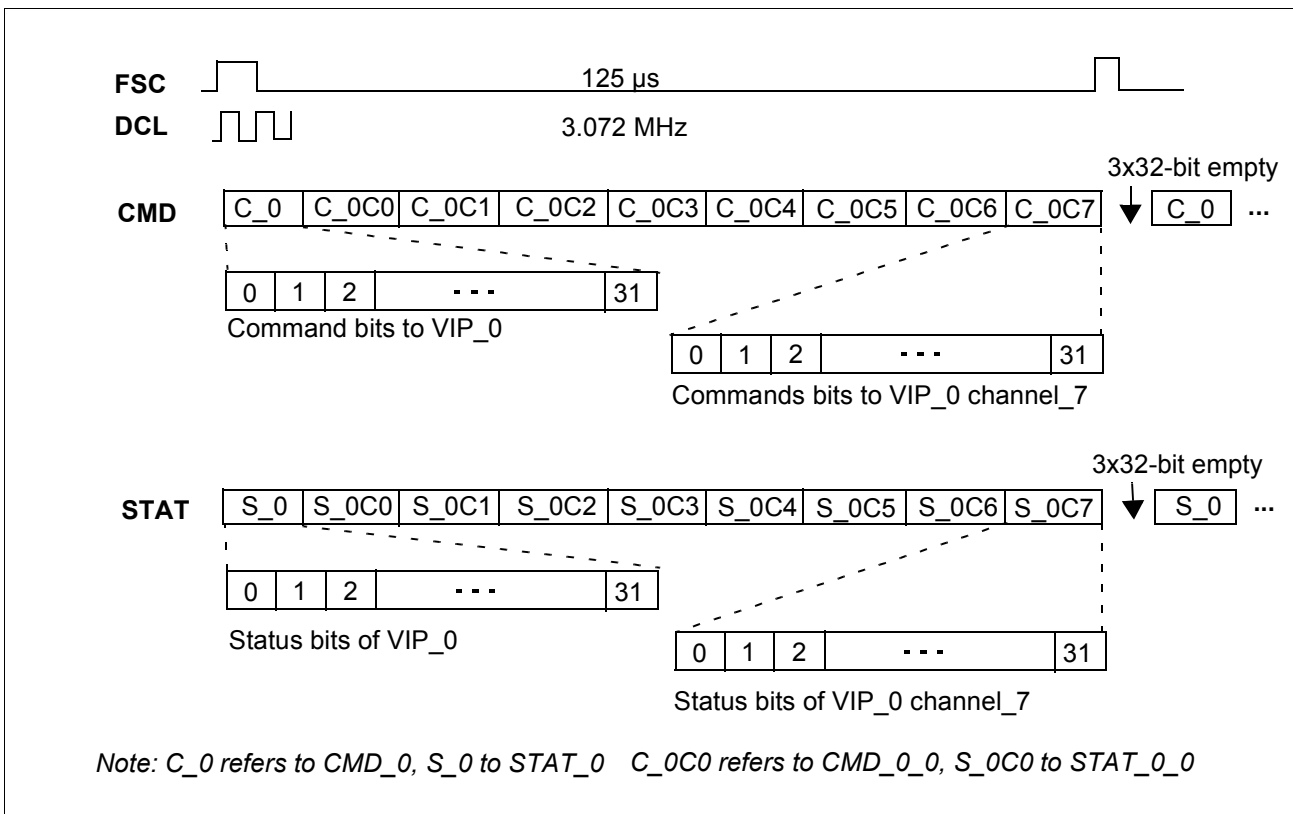

Figure 14 IOM-2000 CMD/STAT Handling (1 VIP with 8 Channels)

Note: The position of each VIP within the IOM-2000 frame is programmable by two VIP pins (VIP_ADR0, VIP_ADR1) to IOM-2000 channels 0..7, 8..15 or 16..23.

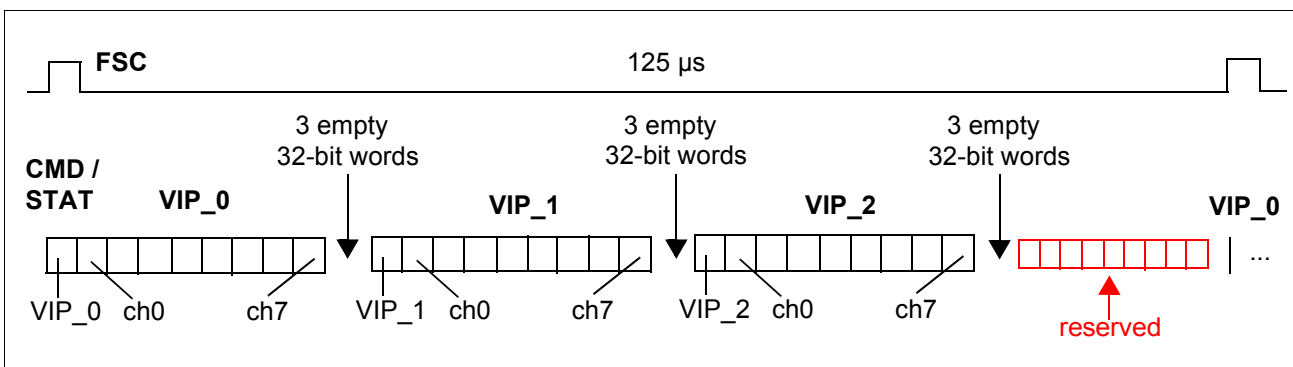
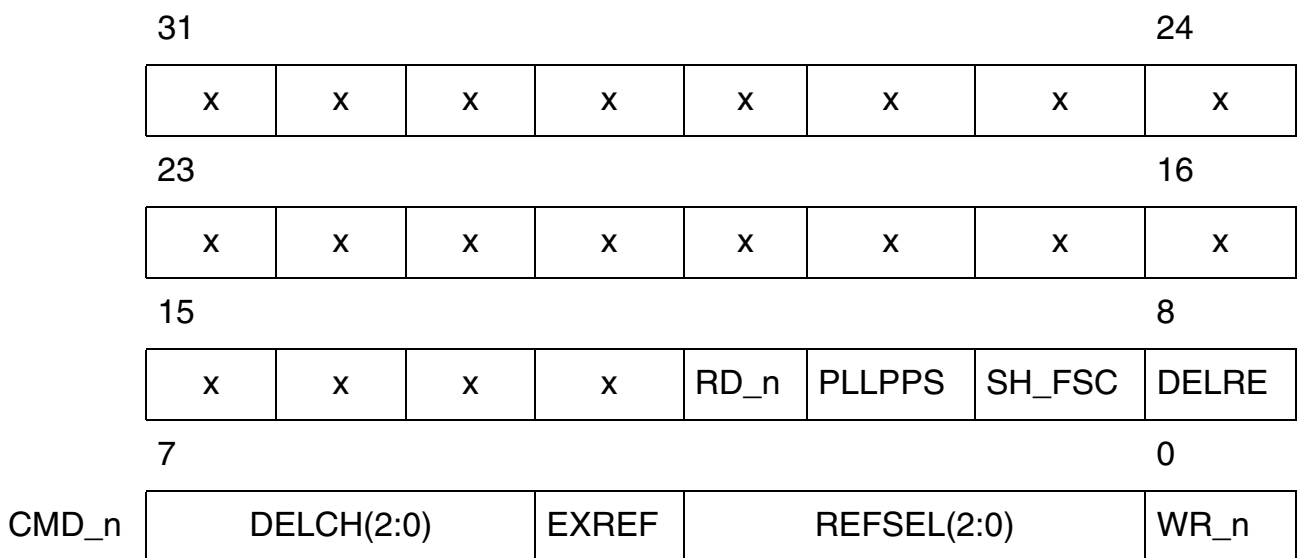

Figure 15 IOM-2000 Command/Status Sequence (3 VIPs with 24 Channels)

Commands to VIP_n (CMD_n, n = 0 ... 2)

Initialization and control information for each VIP is sent by DELIC in the following sequence every 125 μ s via the IOM-2000 CMD line (32 CMD_n bits per VIP_n):

Note: All bits are programmed in VIP Command register (VIPCMR0..2).



Commands to VIP_n, Channel_m (CMD_n_m, m = 0 ... 7)

Initialization and control information for each VIP channel is sent by DELIC in the following sequence every 125 μ s via the IOM-2000 CMD line (32 CMD_n_m bits per VIP_n Channel_m):

Note: All bits except WR_ST, SMINI(2:0) and MSYNC are programmed in TRANSIU Initialization Channel Command register (TICCR); bits WR_ST, SMINI(2:0) and MSYNC reside in the TRANSIU Tx data RAM.



Status from VIP_n (n = 0 ... 2)

Status information is sent by each VIP in the following sequence via the STAT line (32 STAT_n bits per VIP_n):

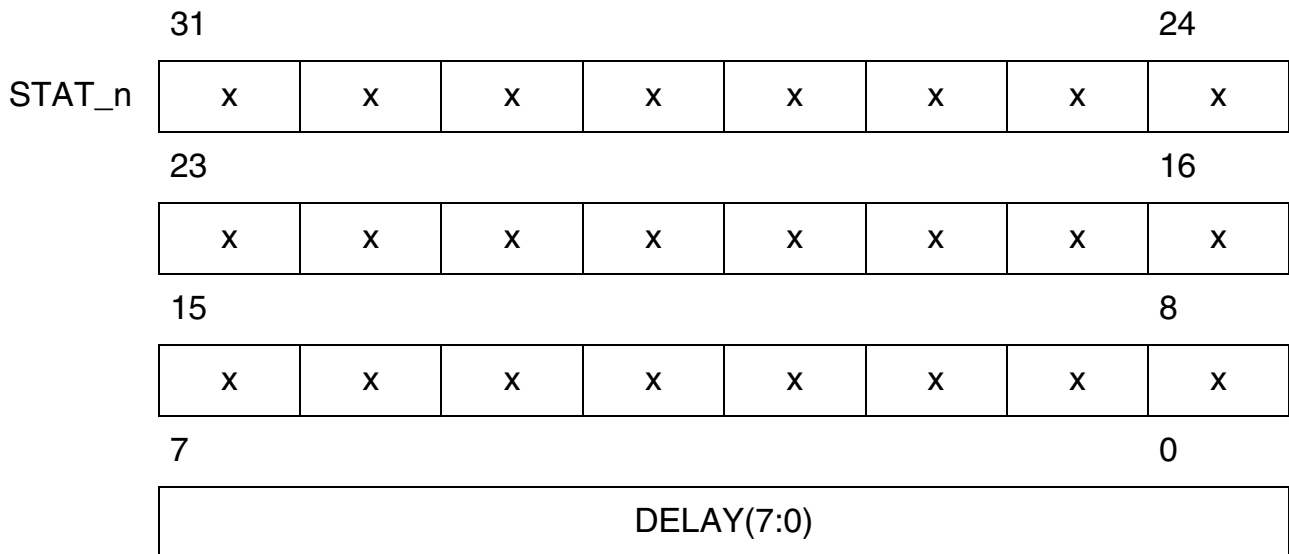

Note: Bits DELAY are read from VIP Status register (VIPSTR) in TRANSIU. x = unused

Status from VIP_n, Channel_m (m = 0 ... 7)

Status information is sent by each VIP channel in the following sequence via the STAT line (32 STAT_n_m bits per VIP_n Channel_m):

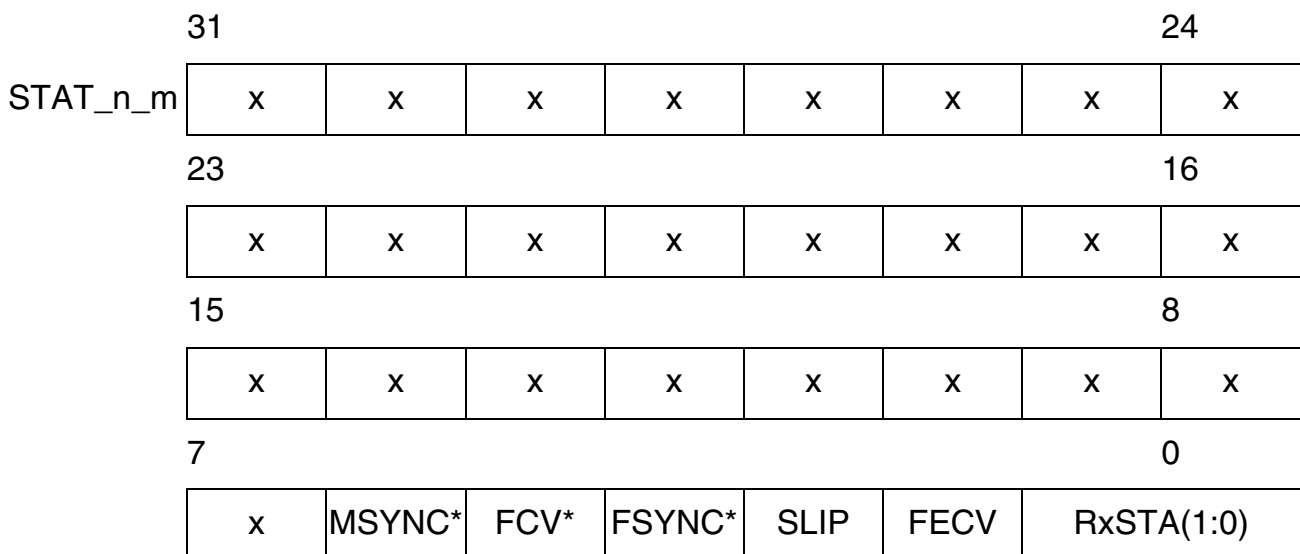

Note: Marked bits (*) are not evaluated by the DELIC, only for VIP testing.

Bits SLIP, FECV and are directly accessible in the TRANSIU receive data RAM.

x = unused

3.2.3 U_{PN} State Machine

3.2.3.1 INFO Structure on the U_{PN} Interface

Signals controlling and indicating the internal state of all U_{PN} transceiver state machines are called INFOs. Four different INFOs (INFO 0, 1W, 1, 2, 3, 4) may be sent over the U_{PN} interface, depending on the actual state (Synchronized, Activated, Pending Activation,...). When the line is deactivated, INFO 0 (=no signal on the line) is exchanged by the U_{PN} transceivers at either end of the line.

When the line is activated, INFO 3 (in upstream direction) and INFO 4 (in downstream direction) are continuously sent. INFO 3 and 4 contain the transmitted data (B1, B2, D, M). INFO 1/2 are used for activation and synchronization.

Table 22 INFO Structure on U_{PN} Interface

Name	Direction	Description
INFO 0	Upstream Downstream	No signal on the line
INFO 1W	Upstream	Asynchronous Wake Signal 2 kHz burst rate F0001000100010001000101010100010111111 Code violation in the framing bit
INFO 1	Upstream	4 kHz burst rate F00010001000100010001010101010001011111M ¹⁾ DC Code violation in the framing bit
INFO 2	Downstream	4 kHz burst rate F00010001000100010001010101010001011111M ¹⁾ Code violation in the frame bit
INFO 3	Upstream	4 kHz burst rate No code violation in the framing bit User data in B, D and M channels B channels scrambled, DC bit ²⁾ optional
INFO 4	Downstream	4 kHz burst rate No code violation in the framing bit User data in B, D and M channels B channels scrambled, DC bit ²⁾ optional

Note: ¹⁾The M channel superframe contains:

CV code violation [1 kbit/s (once in every fourth frame)]

S bits transparent[1 kbit/s channel]

T bits transparent[2 kbit/s channel]

²⁾*DC balancing bit; F = Framing bit*

3.2.3.2 U_{PN} Mode State Diagram

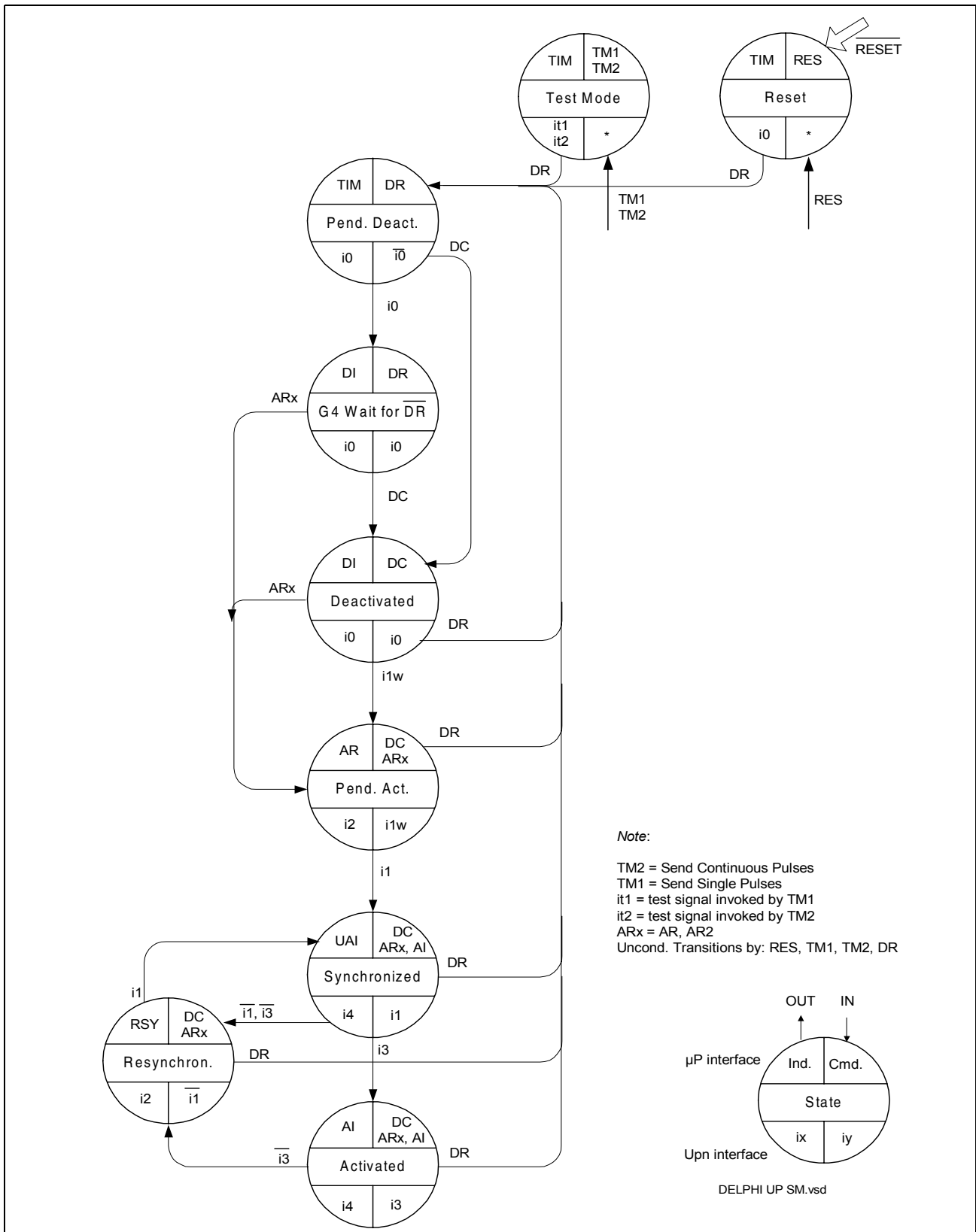

Figure 16 U_{PN} State Diagram

The U_{PN} state machine has unconditional and conditional states (refer to **Figure 16**):

Unconditional States

Reset

This state is entered unconditionally after a low appears on the $\overline{\text{RESET}}$ pin or after the receipt of command RES (software reset). The analog transceiver part is disabled (transmission of INFO 0) and the U_{PN} interface awake detector is inactive. Hence, activation from terminal (TE) is not possible.

Test Mode

The test signal (it_i) sent to the U_{PN} interface in this state is dependant on the command which originally invoked the state. TM1 causes single alternating pulses to be transmitted (it_1); TM2 causes continuous alternating pulses to be transmitted (it_2). The burst mode technique normally employed on the U_{PN} interface is suspended in this state and the test signals are transmitted continuously.

Pending Deactivation

To access any of the conditional states from any of the above unconditional states, the pending deactivation state must be entered. This occurs after the receipt of a DR command. In this state the awake detector is activated and the state is left only when the line has settled (i.e., INFO 0 has been detected for 2 ms) or by the command DC.

Note: Although DR is shown as a normal command, it may be seen as an unconditional command. No matter which state the LT is in, the reception of a DR command will always result in the pending deactivation state being entered.

Conditional States

Wait for $\overline{\text{DR}}$

This state is entered from the pending deactivation state once INFO 0 or DC has been identified. From here the line may be either activated, deactivated or a test loop may be entered.

Deactivated

This is the power down state of the physical protocol. The awake detection is active and the device will respond to an INFO 1w (wake signal) by initiating activation.

Pending Activation

This state results from a request for activation of the line, either from the terminal (INFO 1w) or from the layer-2 device (AR, AR2). INFO 2 is then transmitted and the DSP waits for the responding INFO 1 from the remote device.

Synchronized

This state is reached after synchronization upon the receipt of INFO 1, i.e. after a maximum of 10 ms. In this state, INFO 2 is supplied to the remote terminal for synchronization.

Activated

Info 1 has a code violation in the framing bit (F-bit), whereas INFO 3 has none. Upon the reception of two frames without a code violation in the F bit, the activated state is entered and INFO 4 is transmitted. The line is now activated; INFO 4 is sent to the remote and INFO 3 is received from the remote.

Re-synchronization

If the recognition of INFO 3 fails, the receiver will attempt to resynchronize. Upon entering this state, INFO 2 is transmitted. This is similar to the original synchronization procedure in the pending activation state (the indication given to layer 2 is different). However, as before, recognition of INFO 1 leads to the synchronized state.

Table 23 U_{PN} State Machine Codes

Command	Abbr.	Code	Remark
Deactivate request	DR	0000	Initiates a complete deactivation from the exchange side by transmitting INFO 0 (x)
Reset	RES	0001	(x)
Test mode 1	TM1	0010	Transmission of pseudo-ternary pulses at 2 kHz frequency (x)
Test mode 2	TM2	0011	Transmission of pseudo-ternary pulses at 192 kHz frequency (x)
Activate request	AR	1000	Used to start an exchange initiated activation
Activate request test loop 2	AR2	1010	Transmission of INFO 2, switching of loop 2 (at TE), T bit set to one

Table 23 U_{PN} State Machine Codes (cont'd)

Command	Abbr.	Code	Remark
Activate indication = "blocked"	AI	1100	Transmission of INFO 4, T bit set to zero
Deactivate confirmation	DC	1111	Deactivation acknowledgement, quiescent state

(x) unconditional commands

Note: The U_{PN} state machine does support loops but neither C/I commands (ARL) nor Indications are provided by the mailbox protocol.

An loop can be programmed by setting bits TICCMR:LOOP and TICCMR:EXLP for defining it is an internally or externally loop.

Indication	Abbr.	Code	Remark
Timing	TIM	0000	Deactivate state, activation from the line not possible
Resynchronizing	RSY	0100	Receiver is not synchronous
Activate request	AR	1000	INFO 1w received
U only activation indication	UAI	0111	INFO 1 received, synchronous receiver
Activate indication	AI	1100	Receiver synchronous, i.e., activation completed
Deactivate indication	DI	1111	INFO 0 or DC received after deactivation request

3.2.4 S/T State Machine

A finite state machine in the DELIC controls the VIP S/T line activation/deactivation procedures and transmission of special pulse patterns. Such actions can be initiated by primitives (INFOs) on the S/T interface or by C/I codes sent via the mailbox.

Depending on the application mode and the transfer direction, the S/T state machines support different codes in conditional and unconditional states:

LT-S mode

Codes: data downstream = Commands: reset, test mode, activate req,..
data upstream = Indications: not sync, code violation, timer out,..
States: deactivated, activated, pending, lost framing, test mode

The state diagram is shown in [Figure 17](#).

LT-T mode

Codes data upstream = Commands: reset, test, activate request,..
data downstream = Indications: command x acknowledged,..
Conditional states: power up, pending deactivation, synchronized, slip detected,..

The state diagram is shown in [Figure 18](#).

Unconditional states may be entered from any conditional state and should be left with the command TIM: test mode, reset state,..

The S/T layer-1 activation and deactivation procedures implemented in the DELIC are similar to the ones implemented in the PEB 2084, QUAT-S.

3.2.4.1 LT-S Mode

Table 24 LT-S State Machine Codes

Command	Abbr.	Code	Remark
Deactivate request	DR	0000	Initiates a complete deactivation from the exchange side by transmitting INFO 0 (x)
Reset	RES	0001	(x)
Test mode 1	TM1	0010	Transmission of pseudo-ternary pulses at 2 kHz frequency (x)
Test mode 2	TM2	0011	Transmission of pseudo-ternary pulses at 96 kHz frequency (x)
Activate request	AR	1000	Used to start an exchange initiated activation
Deactivate confirmation	DC	1111	Deactivation acknowledgement, quiescent state

(x) unconditional commands

Note: The LT-S state machine does not support loops. So neither C/I commands nor Indications are provided by the mailbox protocol.

A loop can be programmed by setting bits TICCMR:LOOP and TICCMR:EXLP for the respective channel.

Indication	Abbr.	Code	Remark
Timing	TIM	0000	
Resynchronizing	RSY	0100	Receiver is not synchronous
Activate request	AR	1000	$\overline{\text{INFO 0}}$ received
Code violation received	CVR	1011	After each multi-frame the reception of at least one illegal code violation is indicated four times
Activate indication	AI	1100	Receiver synchronous, i.e., activation completed
Deactivate indication	DI	1111	Timer (32 ms) expired or INFO 0 received after deactivation request

Interface Description

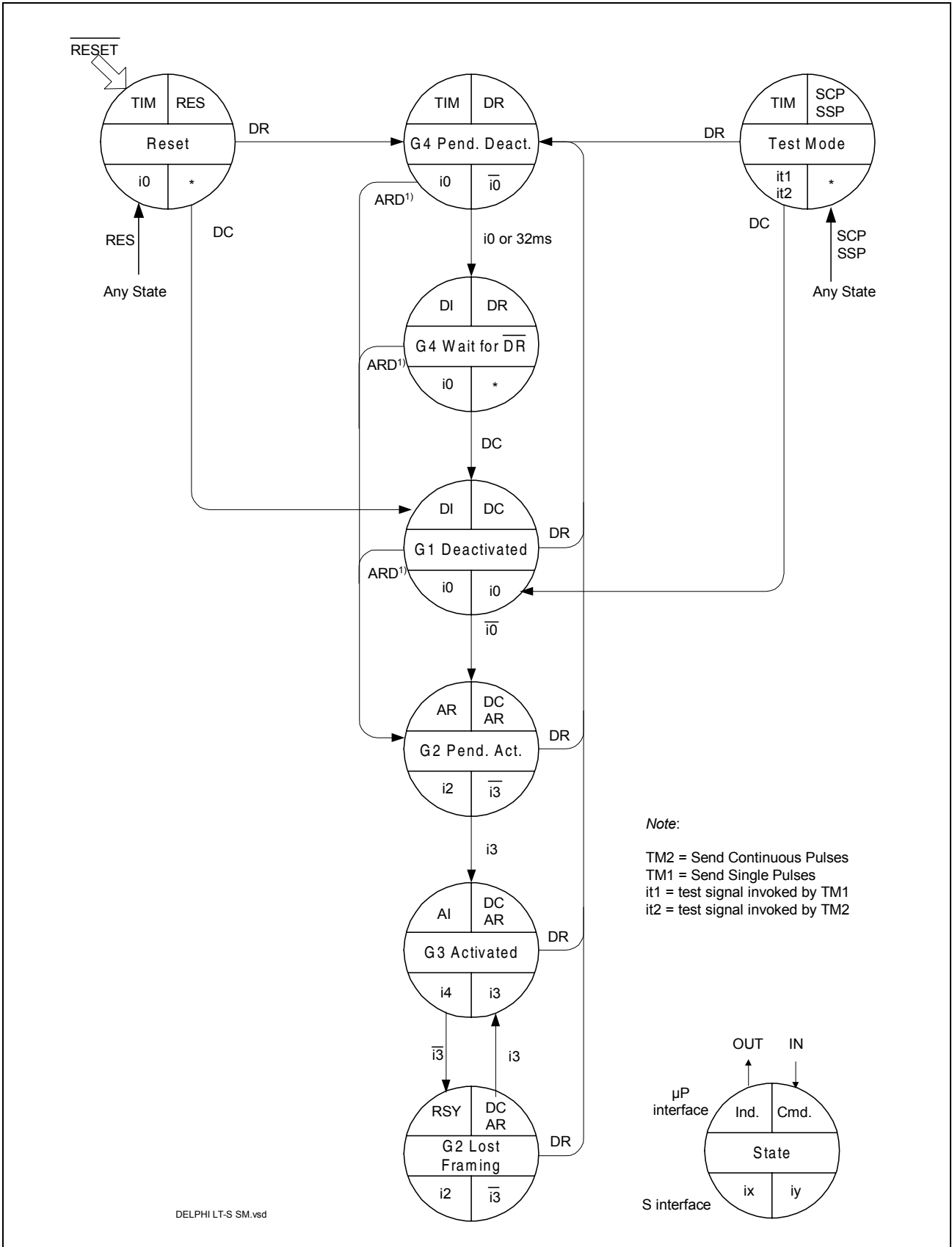

Figure 17 State Diagram of LT-S Mode

LT-S Mode States

- **G1 deactivated**
The line interface is not transmitting. There is no signal detected on the S interface, and no activation command is received.
- **G2 pending activation**
As a result of an INFO 1 detected on the S line or an AR command, the line interface begins transmitting INFO 2 and waits for reception of INFO 3. The timer to supervise reception of INFO 3 is to be implemented in software. In case of an ARL command, loop 2 is closed.
- **G3 activated**
Normal state where INFO 4 is transmitted to the S interface. The line interface remains in this state as long as neither a deactivation nor a test mode is requested, and the receiver does not lose synchronism. When receiver synchronism is lost, INFO 2 is sent automatically. After reception of INFO 3, the transmitter continues sending INFO 4.
- **G2 lost framing**
This state is reached when the line interface has lost synchronism in the state G3 activated.
- **G4 pending deactivation**
This state is triggered by a deactivation request DR. It is an unstable state: status DI (state "G4 wait for DR") is issued by the DELIC when either INFO 0 is received, or an internal timer of 32 ms expires.
- **G4 wait for DR**
Final state after a deactivation request. The line interface remains in this state until a response to DI (in other words DC) is issued.
- **Test mode 1**
Single alternating pulses are sent on the S interface (2 kHz repetition rate).
- **Test mode 2**
Continuous alternating pulses are sent on the S interface (96 kHz).

3.2.4.2 LT-T Mode

Table 25 LT-T Mode State Machine Codes (Conditional States)

Command	Abbr.	Code	Remark
Timing Request	TIM	0000	Requests the line interface to change into power-up state
Reset	RES	0001	Reset of state machine. Transmission of Info 0. No reaction to incoming infos (x)
Test mode 1	TM1	0010	Transmission of single pulses on the S/T-interface. The pulses are transmitted with alternating polarity at a frequency of 2 kHz. (x)
Test mode 2	TM2	0011	Transmission of continuous pulses on the S/T-interface. The pulses are sent with alternating polarity at a rate of 96 kHz. TM2 is an unconditional command (x).
Activate request, priority 8	AR8	1000	Activation Request with priority 8 for D-channel transmission. This command is used to start a LT-T initiated activation. D-channel priority 8 is the highest priority. It should be used to request signaling information transfer.
Activate request, priority 10	AR10	1001	Activation request with priority 10 for D-channel transmission. This command is used to start a LT-T initiated activation. D-channel priority 10 is a lower priority. It should be used to request packet data transfer.
Activate request loop	ARL	1010	Activation of loop 3 (x)
Deactivate indication	DI	1111	This command forces the line interface into "F3 power down" mode.

(x) unconditional commands

Interface Description

Indication	Abbr.	Code	Remark
Deactivate request	DR	0000	Deactivation request if left from F7/F8
Reset	RES	0001	Reset acknowledge
Test mode 1	TM1	0010	TM1 acknowledge
Test mode 2	TM2	0011	TM2 acknowledge
Slip detected	SLIP	0011	Frame wander larger than +/- 25 μ s
Re-synchronization during level detect	RSY	0100	Signal received, receiver not synchronous
Power up	PU	0111	Line interface is powered up
Activate request	AR	1000	INFO 2 received
Activate request loop	ARL	1010	Loop 3 closed
Code violation received	CVR	1011	After each multiframe the reception of at least one illegal code violation is indicated four times.
Activate indication loop	AIL	1110	Loop 3 activated
Activate indication with priority class 8	AI8	1100	INFO 4 received, D-channel priority is 8 or 9
Activate indication with priority class 10	AI10	1101	INFO 4 received, D-channel priority is 10 or 11
Deactivate confirmation	DC	1111	Line interface is powered down

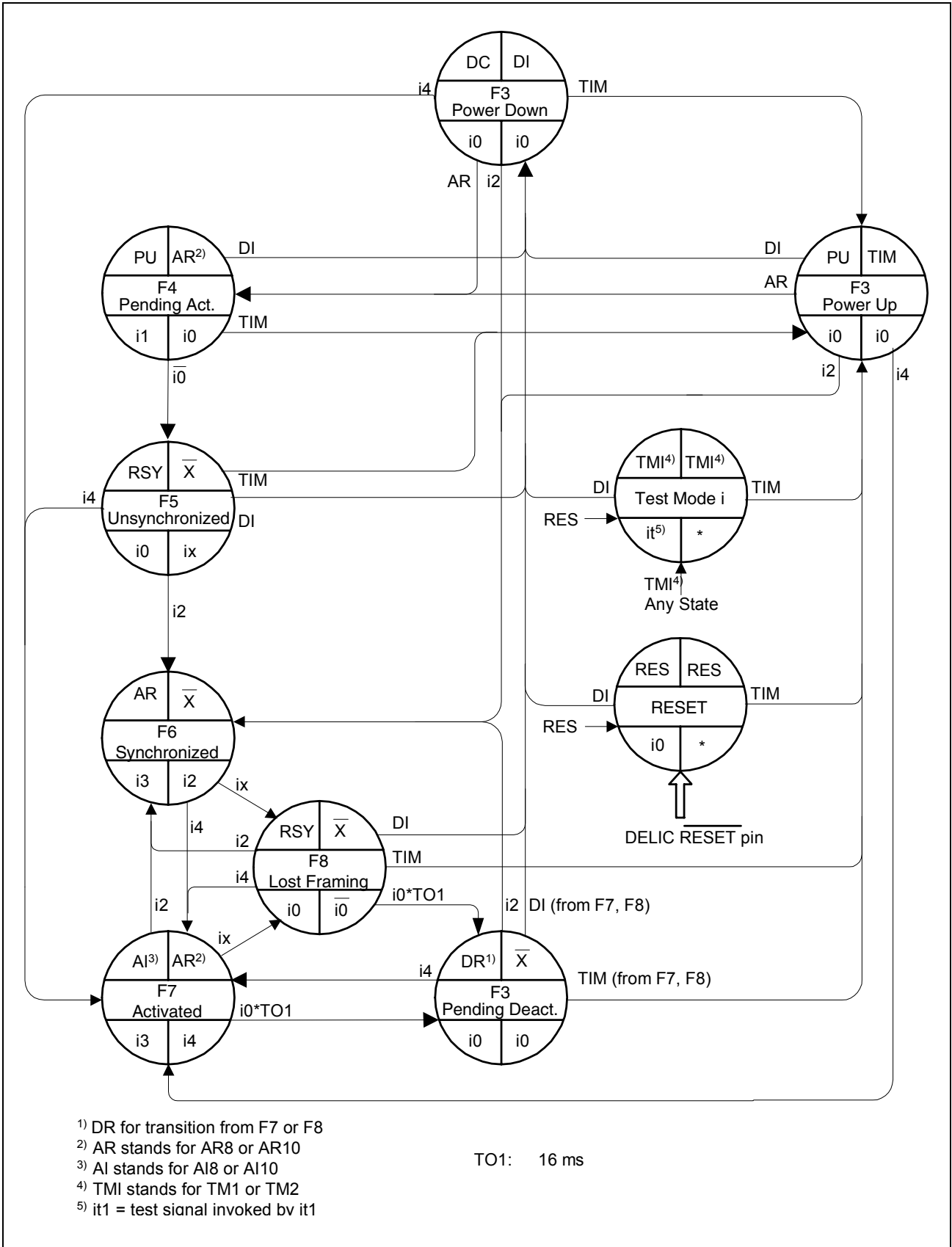

Figure 18 LT-T Mode State Diagram (Conditional and Unconditional States)

LT-T Mode (Conditional States)

- F3 power down
This is the deactivated state of the physical protocol. The receive line awake unit is active.
- F3 power up
This state is similar to “F3 power down”. The state is invoked by a Command TIM = “0000” (or DI static low).
- F3 pending deactivation
The line interface reaches this state after receiving INFO 0 (from states F5 to F8). From this state an activation is only possible from the line (transition “F3 pending deactivation” to “F5 unsynchronized”). The power down state may be reached only after receiving DI.
- F4 pending activation
Activation has been requested from the terminal; INFO 1 is transmitted; INFO 0 is still received; “Power Up” is transmitted in the C/I channel. This state is stable: timer T3 (ITU I.430) is to be implemented in software.
- F5/8 unsynchronized
At the reception of any signal the VIP ceases to transmit INFO 1, adapts its receiver circuit, and awaits identification of INFO 2 or INFO 4. This state is also reached after the line interface has lost synchronism in the states F6 or F7 respectively.
- F6 synchronized
When the VIP receives an activation signal (INFO 2), it responds with INFO 3 and waits for normal frames (INFO 4).
- F7 activated
This is the normal active state with the layer 1 protocol activated in both directions. From state “F6 synchronized”, state F7 is reached almost 0.5 ms after reception of INFO 4.
- F7 slip detected
When a slip is detected between the T interface clocking system and the IOM-2 interface clocks (phase wander of more than 25 μ s, data may be disturbed) the line interface enters this state, synchronizing again the internal buffer. After 0.5 ms this state is relinquished.

LT-T Mode (Unconditional States)

The unconditional states should be left with the command TIM.

- Test mode 1
Single alternating pulses are sent on the T interface (2 kHz repetition rate).
- Test mode 2
Continuous alternating pulses are sent on the T interface (120 kHz).
- Reset state
A hardware or software reset (RES) forces the line interface to an idle state where the analog components are disabled (transmission of INFO 0) and the T line awake detector is inactive.

Restriction in LT-T Mode

The two first TRANSIU Channels out of 24, (i.e. Channel_0 and channel_1 in the IOM-2000 frame, referring to VIP_0, ch_0 and ch_1) do not work in LT-T mode.

In order to have an optimized usage of the LT-channels it is recommended to proceed as follows:

- If only one VIP is used, 8 channels can be applied in LT-T mode by using a DCL_2000 clock of 6.144 MHz and mapping the VIP to channel 8..15.
- If 2 VIPs are used, up to 16 channels can be applied in LT-T mode by using a DCL_2000 of 12.288 MHz and mapping the VIPs to channel 8..23.
- If 3 VIPs are used up to 22 channels (channel 2..23) may be applied in LT-T mode by using a DCL_2000 of 12.288 MHz.

3.3 IOM[®]-2 Interface

IOM-2 is a standardized interface for interchip communication in ISDN line cards for digital exchange systems developed by ALCATEL, Siemens, Plessey and ITALTEL.

The IOM-2 interface is a four-wire interface with a bit clock, a frame clock and one data line per direction. It has a flexible data clock. This way, data transmission requirements are optimized for different applications.

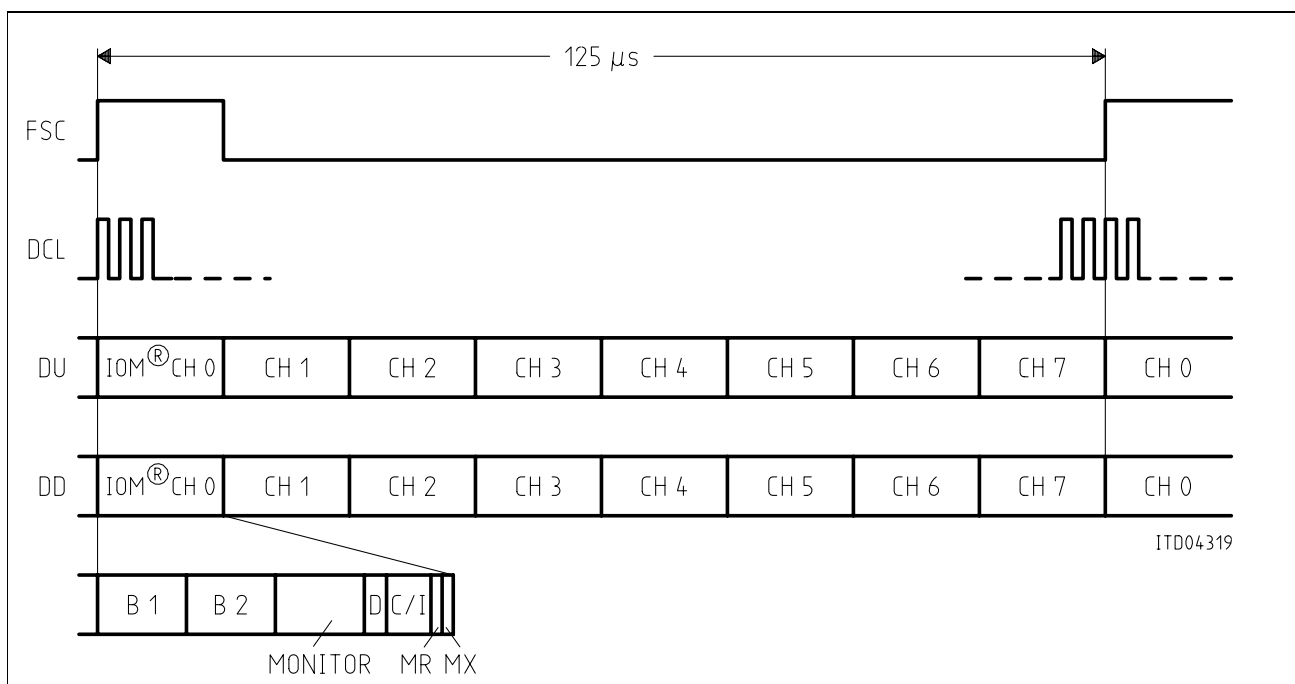

Figure 19 IOM[®]-2 Interface in Digital Line Card Mode

Note: In Laundered mode, 8 identical IOM-2 subchannels are provided. In analog Line cards, a 6-bit C/I Channel is available for signaling information. In digital Line cards, a dedicated 2-bit D-channel carries the signaling information.

3.3.1 Signals / Channels

FSC	Frame Synchronization Clock, 8 kHz
DCL	Data Clock, up to 4.096 MHz *)
DD	Data Downstream, up to 4.096 Mbit/s *)
DU	Data Upstream, up to 4.096 Mbit/s *)
B1, B2	User data channels, 64 kbit/s each
MONITOR	Monitor Channel
D	Signaling Channel, 16 kbit/s
C/I	Command/Indication Channel
MR	Monitor Receive handshake signal
MX	Monitor Transmit handshake signal

*) For detailed clock and data rates, refer to IOMU feature description in [Chapter 4.3.2](#)

3.4 μ P Interface

The μ P interface may be operated in different modes. This chapter describes how to configure the DELIC to each mode.

3.4.1 Intel/Infineon or Motorola Mode

The processor mode is selected by the MODE input pin of the DELIC. "Low" level selects Infineon/ INTEL mode, "HIGH" level selects Motorola mode.

3.4.2 De-Multiplexed or Multiplexed Mode

In both modes, the A-bus and the D-bus are used in parallel. The A-bus should be connected to the 8 LSBs of AD-bus, coming from the μ P, also in multiplexed mode. The mode is determined according to the ALE input pin. When ALE is permanently driven to '1', the DELIC works in de-multiplexed mode. Otherwise the DELIC works in multiplexed mode.

The next figure describes the connection of the DELIC to the address and data buses in the different modes.

Note: Motorola mode is used only with de-multiplexed AD bus. Intel/Infineon mode may be used with both, multiplexed or de-multiplexed AD bus.

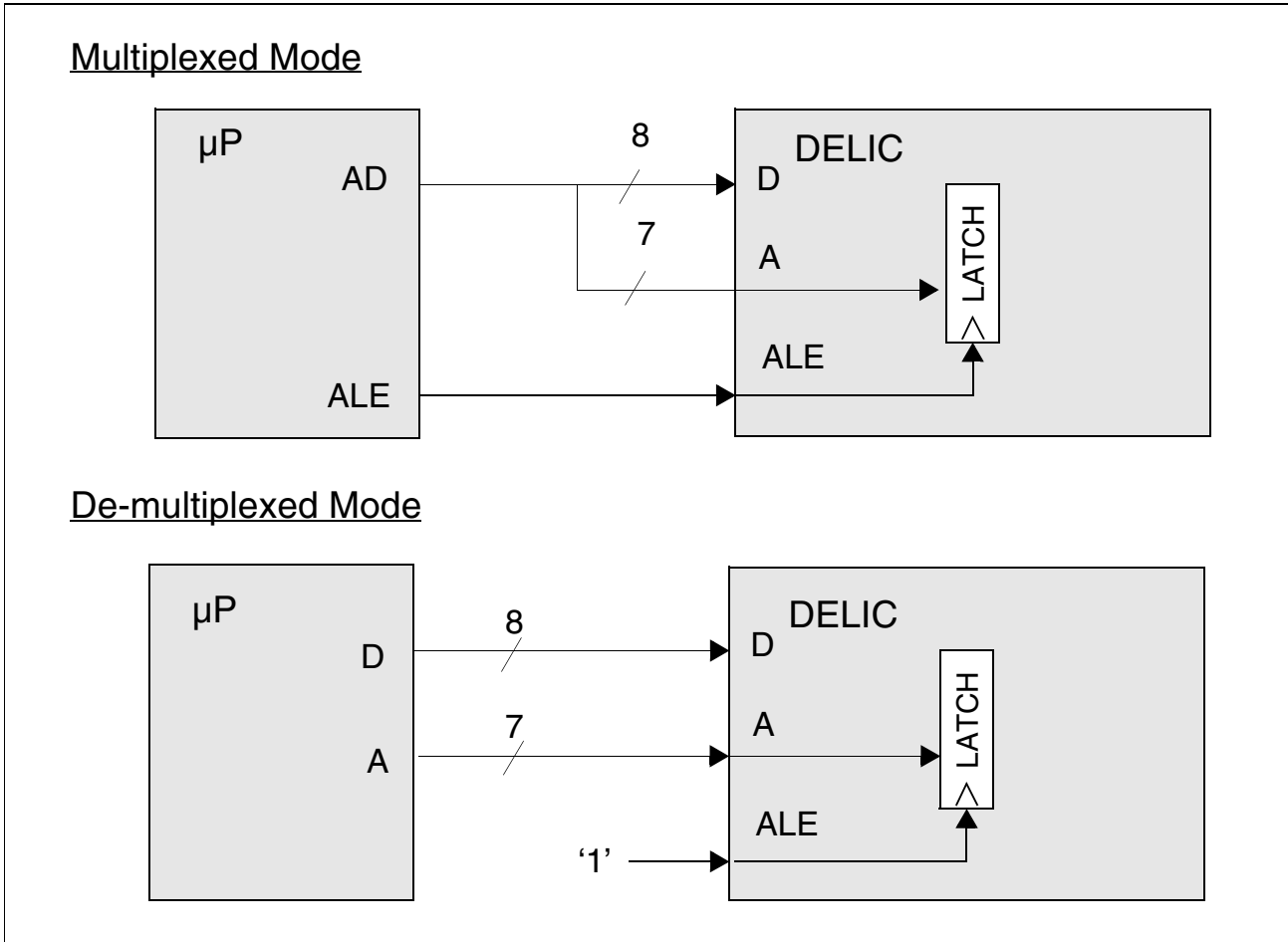

Figure 20 DELIC in Multiplexed and in De-Multiplexed Bus Mode

Note: In both modes only the 7 LSBs of A-bus or AD/bus are connected to the Address inputs of the DELIC. In DMA mode $\overline{DACK/A4}$ input pin is used as \overline{DACK} , and A4 is internally driven to '0'. In this case A4 of the μP A/AD-bus is also not connected to the DELIC.

3.4.3 DMA or Non-DMA Mode

The internal interface between the on-chip DSP and μ P is established by two Mailboxes: a 'general' Mailbox and a dedicated DMA Mailbox. The non-DMA mode provides the option to combine them together building a double-sized 'general' Mailbox. The DELIC is configured to DMA or non-DMA mode by a dedicated bit in the μ P interface configuration register (MCFG:DMA).

DMA Mode

The DMA Mailbox can be accessed only by a DMA controller. The $\overline{\text{DACK}}$ input pin (together with the $\overline{\text{RD}}$ and $\overline{\text{WR}}$ signals) is used to access the DMA Mailbox. Only the general Mailbox can be accessed directly by the μ P. In DMA mode, the pin $\overline{\text{DACK/A4}}$ is used as $\overline{\text{DACK}}$, and A4 of the A-bus or AD-bus coming from the μ P must not be used as an address line for the DELIC. In this case A4 is driven internally to '0'.

Note: In de-multiplexed mode AD4 should be connected to DELIC's D4input pin.

Non-DMA mode

This is the default mode (after reset). The general Mailbox and the DMA Mailbox data registers are concatenated into one double-sized general Mailbox, accessible by the μ P. This broad Mailbox consists of a dedicated μ P Mailbox and a DSP Mailbox. Each of them contains 32 data bytes and 1 command byte. In non-DMA mode, $\overline{\text{DACK/A4}}$ is used as A4, in order to include the DMA Mailbox data registers in the μ P interface address space.

3.4.4 DELIC External Interrupts

The DELIC contains only one source for an external interrupt - the general Mailbox. This interrupt source is the OCMD register of the DSP Mailbox. Releasing the interrupt is done by the μ P resetting bit OBUSY:BUSY. Masking it may be done by resetting the MASK bit of the μ P interface Configuration Register (MCFG:IMASK).

The interrupt vector issued is the contents of the DSP Mailbox command register MCMD. In Motorola mode, the interrupt vector is issued upon the first $\overline{\text{IACK}}$ pulse, while in Infineon/Intel mode it is issued upon the second $\overline{\text{IACK}}$ pulse. In the latter case, the interrupt vector due to the first $\overline{\text{IACK}}$ pulse (if needed), should be issued by an external interrupt controller.

3.5 JTAG Test Interface

The DELIC provides fully IEEE Standard 1149.1 compatible boundary scan support to allow cost effective board testing. It consists of:

- Complete boundary scan test
- Test access port controller (TAP)
- Five dedicated pins: JTCK, TMS, TDI, TDO (according to JTAG) and an additional $\overline{\text{TRST}}$ pin to enable asynchronous resets to the TAP controller
- One 32-bit IDCODE register

3.5.1 Boundary Scan Test

Depending on the pin functionality one or two boundary scan cells are provided.

Pin Type	Number of Boundary Scan Cells	Usage
Input	1	Input
Output	2	Output, enable

When the TAP controller is in the appropriate mode data is shifted into/out of the boundary scan via the pins TDI/TDO using a clock of up to 6.25 MHz on pin JTCK.

The sequence of the DELIC pins can be taken from the BSDL files.

3.5.2 TAP Controller

The Test Access Port (TAP) controller implements the state machine defined in the JTAG standard IEEE 1149.1. Transitions on the pin TMS cause the TAP controller to perform a state change.

The TAP controller supports a set of 5 standard instructions:

Table 26 TAP Controller Instruction Codes

Code	Instruction	Function
0000	EXTEST	External testing
0001	INTEST	Internal testing
0010	SAMPLE/PRELOAD	Snap-shot testing
0011	IDCODE	Reading ID code register
1111	BYPASS	Bypass operation

EXTEST is used to verify the board interconnections.

When the TAP controller is in the state “update DR”, all output pins are updated with the falling edge of JTCK. When it has entered state “capture DR” the levels of all input pins are latched with the rising edge of JTCK. The in/out shifting of the scan vectors is typically done using the instruction SAMPLE/PRELOAD.

INTEST supports internal chip testing.

When the TAP controller is in the state “update DR”, all inputs are updated internally with the falling edge of JTCK. When it has entered state “capture DR” the levels of all outputs are latched with the rising edge of JTCK. The in/out shifting of the scan vectors is typically done using the instruction SAMPLE/PRELOAD.

Note: 0011 (IDCODE) is the default value of the instruction register.

SAMPLE/PRELOAD provides a snap-shot of the pin level during normal operation or is used to either preload (TDI) or shift out (TDO) the boundary scan test vector. Both activities are transparent to the system functionality.

IDCODE

The 32-bit identification register is serially read out via TDO. It contains the version number (4 bits), the device code (16 bits) and the manufacturer code (11 bits). The LSB is fixed to '1'. The code for the DELIC version 3.1 is '0100'.

Version	Device Code	Manufacturer Code	Output
0100	0000 0000 0101 0111	0000 1000 001	1 --> TDO

Note: In the state “test logic reset” the code “0011” is loaded into the instruction code register.

BYPASS, a bit entering TDI is shifted to TDO after one JTCK clock cycle, e.g. to skip testing of selected ICs on a printed circuit board.

4 Functional Description

As the functionality of the DELIC-PB comprises the functionality of the DELIC-LC, the following chapter describes the functionality of the DELIC-PB. The differences between the two chip versions (considering also the firmware) can be seen below:

Table 27 Differences Between DELIC-LC and DELIC-PB

Functionality	DELIC-LC	DELIC-PB
GHDLC channels (maximum configuration)	Cha. 0	Cha. 0..3
GHDLC maximum data rate	2 MBit/s	8 MBit/s
HDLC channels (maximum configuration)	Cha. 0..23	Cha. 0..31
DMA interface	not available	available
DMA- mailbox	not available; it is used to increment the general mailbox	can be used for DMA operation or as general mailbox
Number of switching connections (8-bit)	256	variable, limited by DSP-RAM
Multi-bit switching (1-bit, 2-bit, 3-bit...7-bit)	no	yes
DECT-synchronization and delay measurement support	no	yes
'Firmware Alive Indication' function	no	yes
DSP- Run time statistic counter	without threshold	with threshold
DSP-PBX-library for conferencing, tone generation/ detection, DTMF receiver/ generator music on hold ¹⁾	no	yes
Free programmability of DSP-system	no	yes

¹⁾ These libraries are included in the DELIC-PB configurator.

4.1 Functional Overview and Block Diagram

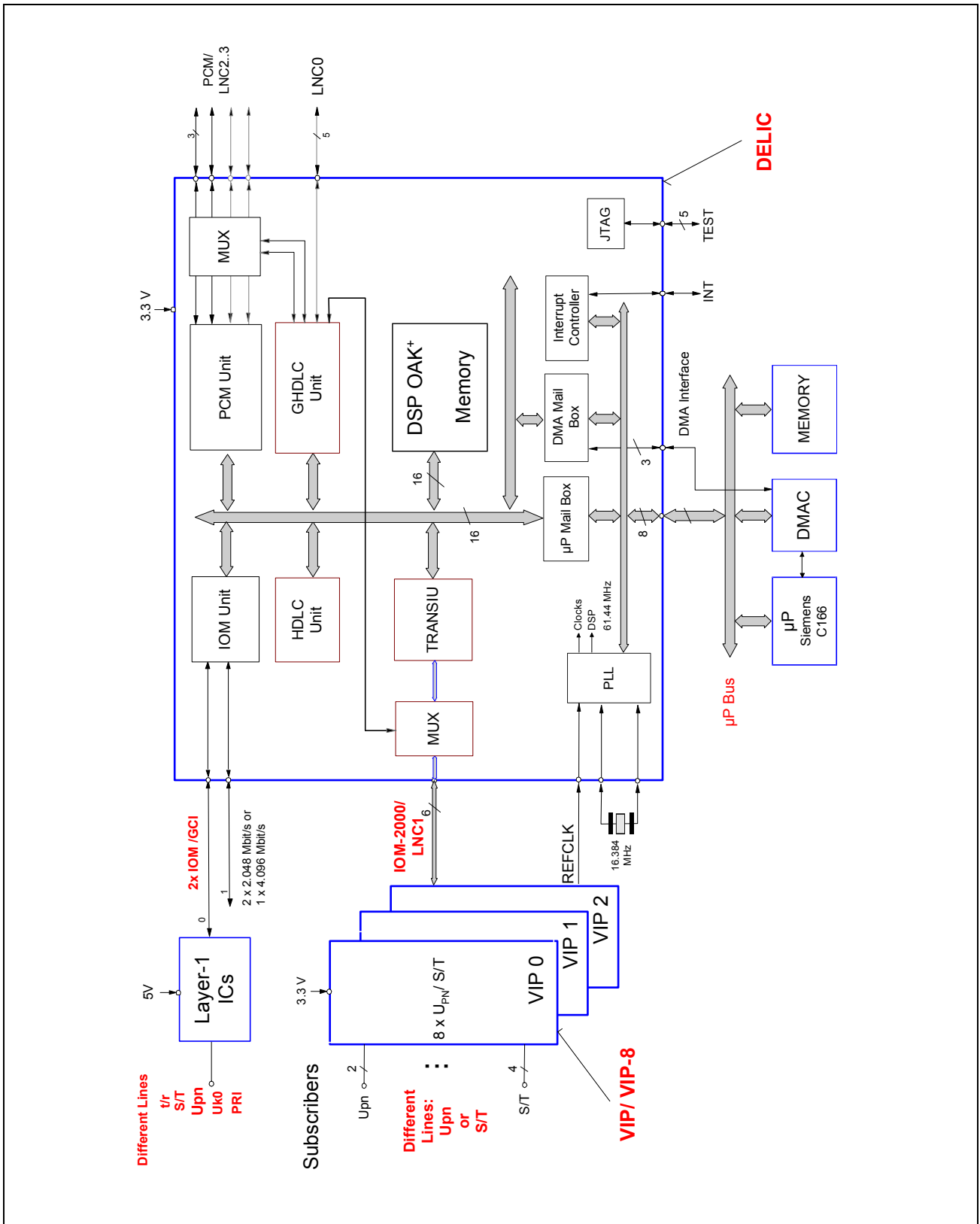

Figure 21 Block Diagram

4.2 IOM-2000 Transceiver Unit (TRANSIU)

4.2.1 IOM-2000 Features

- The TRANSIU controls up to 24 layer-1 channels via up to three VIP/ VIP8 connected to IOM-2000 interface
- IOM-2000 interface: all channels may be programmed in the IOM-2000 to:
 - U_{PN} interface
 - S/T interface in LT-S (subscriber master) or LT-T (trunk slave) mode

Note: The number of S/T interfaces in VIP PEB 20590 is limited to 4. Therefore it is required to program the IOM-2000 correctly to the required mode (refer to [Table 49](#))

- Clock rates: 3.072 Mbit/s (1 VIP), 6.144 Mbit/s (2 VIPs) or 12.288 Mbit/s (3 VIPs)
- Data and maintenance bit handling for S/T and U_{PN} interface, including multiframe control and D-channel collision control.

Scrambling / Descrambling (in DELIC)

The B-channel data on the Up interface is scrambled in order to ensure that the receiver at the subscriber terminal gets enough pulses for a reliable clock extraction (flat continuous power density spectrum is provided), and to avoid periodic patterns on the line.

A descrambler is implemented in the opposite direction to extract the received Up data. The scrambling is done according to ITU V.27, OCTAT-P and DASL.

4.2.2 IOM-2000 Initialization

Channel Programming

Each IOM-2000 channel may be configured in the TRANSIU as:

- U_{PN} mode
- S/T channel in LT-S mode
- S/T channel in LT-T mode

Data Rate Programming

The IOM-2000 supports three configurations regarding the number of VIPs connected via IOM-2000:

- One VIP connected at data rate of 3.072 Mbit/s: 8 IOM-2000 channels at a clock rate of 3.072 MHz (for LT-T mode please refer to [Page 62](#))
- Two VIPs connected at data rate of 6.144 Mbit/s: 16 IOM-2000 channels at a clock rate of 6.144 MHz

Functional Description

- Three VIPs connected at data rate of 9.216 Mbit/s: 24 IOM-2000 channels at a clock rate of 12.288 MHz. (Note the difference between clock rate and actual data rate)

4.2.3 Initialization of the VIP

During startup the VIP requires 3 frames with the right FSC and DCL_2000 to synchronize to the DELIC. During this time the VIP is not able to detect commands or data from the DELIC. Therefore, the delayed reset signal RESIND of the DELIC should be used to reset the VIP.

4.2.4 IOM-2000 Command and Status Interface

All Command/Status bits used for VIP channel programming are divided into one group used only during initialization, and one group used during normal operation.

4.2.4.1 Initialization Mode Command Bits

The bits of this group are used for VIP initialization or in operation modes where an immediate reaction is not required. The initialization group includes command bits and the channel address, stored in register TICCMR.

Note: The usage of this group of bits is limited in a way that only one channel may be accessed in each frame.

In test mode, the command word to VIP_n (CMD_n) and to Channel_m of VIP_n (CMD_n_m) may be read by the DELIC in the next frame after issuing bits 'RD_n' or 'RD'. The VIP mirrors the command word exactly as it was received, despite the bits 'WR', 'WR_ST', 'RD'. The VIP status is saved in the TRANSIU initialization status (TICSTR) register, which includes status bits and the channel address.

Note: The commands must not be read during normal operation, since in this case the reporting of the VIP status to the DELIC would not be possible.

4.2.4.2 Operational Mode Command/Status Bits

The bits of this group are used during normal operation, hence they are evaluated in every frame. They include all VIP receiver status bits and some of the command bits. The operational mode command/status bits are buffered in the Data RAM.

The VIP receiver status bits do not reflect a status change, but the status itself, i.e. the current value of the line interface INFOs, until the values change.

The FECV is only reported to the DELIC upon changes.

4.2.4.3 Command/Status Transmission

The command/status bits are transmitted/received by the TRANSIU at the same rate as data transmission rate, starting with the 8 kHz FSC.

Transmit Direction

- The command information per VIP is prepared by the DSP in the VIPCMR0-2 registers
- The command bits from initialization command group are prepared by the DSP in the TICCMR register for one of the channels
- TRANSIU operation mode command format in the Data RAM

Receive Direction

- The received status per VIP is stored in the VIPSTR0-2 registers
- If the “read_status” command was transmitted in the previous frame for one of the channels, the received status from this channel is saved in the TICSTR register together with the 5-bit channel address
- TRANSIU operation mode status format in the Data RAM

4.2.4.4 Command and Status format in the Data RAM

The operational mode command and status bits usually are served completely by the firmware. So there is no need to set this bits by the user.

Operational Mode Command bits in the data RAM:

Address: see memory map

7	6	5	4	3	2	1	0
data byte 1							
data byte 2							
data byte 3							
x	x	x	SMINI(2:0)			MSYNC	WR_ST

WR_ST	Write Command to TST1 Bits (S/T, U _{PN}) 0 = Data sent in these bits is invalid 1 = SMINI(2:0) and MSYNC contain valid data
MSYNC	Multiframe Synchronization (LT-T) 0 = VIP mirrors the F _A -bit 1 = VIP stops the F _A -bit mirroring (for multiframe synchronization)
SMINI(2:0)	State Machine Initialization (S/T, U _{PN}) Command to VIP from the DELIC layer-1 state machine. Depending on the state, the VIP may transmit data on the U _{PN} or S/T interface. The VIP responds by sending the receiver status bits STAT_n_m.RxSTA(1:0) to the DELIC. 000 = INFO 0 in S/T or U _{PN} 001 = INFO 1w in U _{PN} 010 = INFO 1 in LT-T, INFO 2 in LT-S or U _{PN} 011 = INFO 3 in LT-T, INFO 4 in LT-S or U _{PN} 100 = Test mode 'Send Continuous Pulses SCP': '1s' transmitted at 96 kHz (U _{PN}) and at 192 kHz S/T) 101 = Test mode 'Send Single Pulses SSP' (at 2 kHz burst rate) all other states are reserved

Operational Mode Status bits in the data RAM:

Address: see memory map

7	6	5	4	3	2	1	0
data byte 1							
data byte 2							
data byte 3							
x	MSYNC	FCV	FSYNC	SLIP	FECV	RxSTA(1:0)	

- RxSTA(1:0) Receiver Status Change (S/T, U_{PN})
 00 = Receiver is not synchronized to the line; no signal on line (INFO 0)
 01 = Level detected on line (any signal) (INF 1 in LT-S mode)
 10 = Receiver is synchronized to the line, but not activated (INFO 2 in LT-T mode)
 11 = Receiver is synchronized and activated (INFO 4 for LT-T mode INFO 3 for LT-S and U_{PN})
- FECV Far-end Code Violation (S/T, U_{PN})
 0 = Normal operation
 1 = Illegal code: FECV according to ANSI T1.605 detected (S/T)
- SLIP Frame Slip Detected (LT-T)
 0 = No frame slip detected
 1 = A frame slip of more than 20 μs was detected on the LT-T channel
- FSYNC * F-Bit Synchronous (S/T + U_{PN} test mode only!)
- FCV * Code Violation in F-Bit detected (U_{PN} test mode only!)
- MSYNC / LD * Multiframe Synchronous (U_{PN}), Level Detected (S/T), test mode!

*Note: with * marked bits are not evaluated by the DELIC, only for VIP testing.
 Bits SLIP, FECV and are directly available to the DSP software in the TRANSIU receive data RAM.*

4.2.5 U_{PN} Mode Frame Structure

The U_{PN} interface uses a ping-pong technique for 2B+D data transmission over the line. U_{PN} is always point-to-point.

The frame structure of the data transfer between the exchange (PBX, LT) and the terminal (TE) is depicted in **Figure 22**.

- The PBX starts a transmission every 250 μs (burst repetition period).
- A frame transmitted by the exchange (PBX) is received by the terminal (TE) after a given propagation delay t_d .
- The terminal waits a minimum guard time ($t_g = 5.2 \mu\text{s}$) while the line clears. Then a frame is transmitted from the terminal to the PBX.
- The time between the end of reception of a frame from the TE and the beginning of transmission of the next frame by the LT must be greater than the minimum guard time. The guard time in TE is always defined with respect to the M-bit.

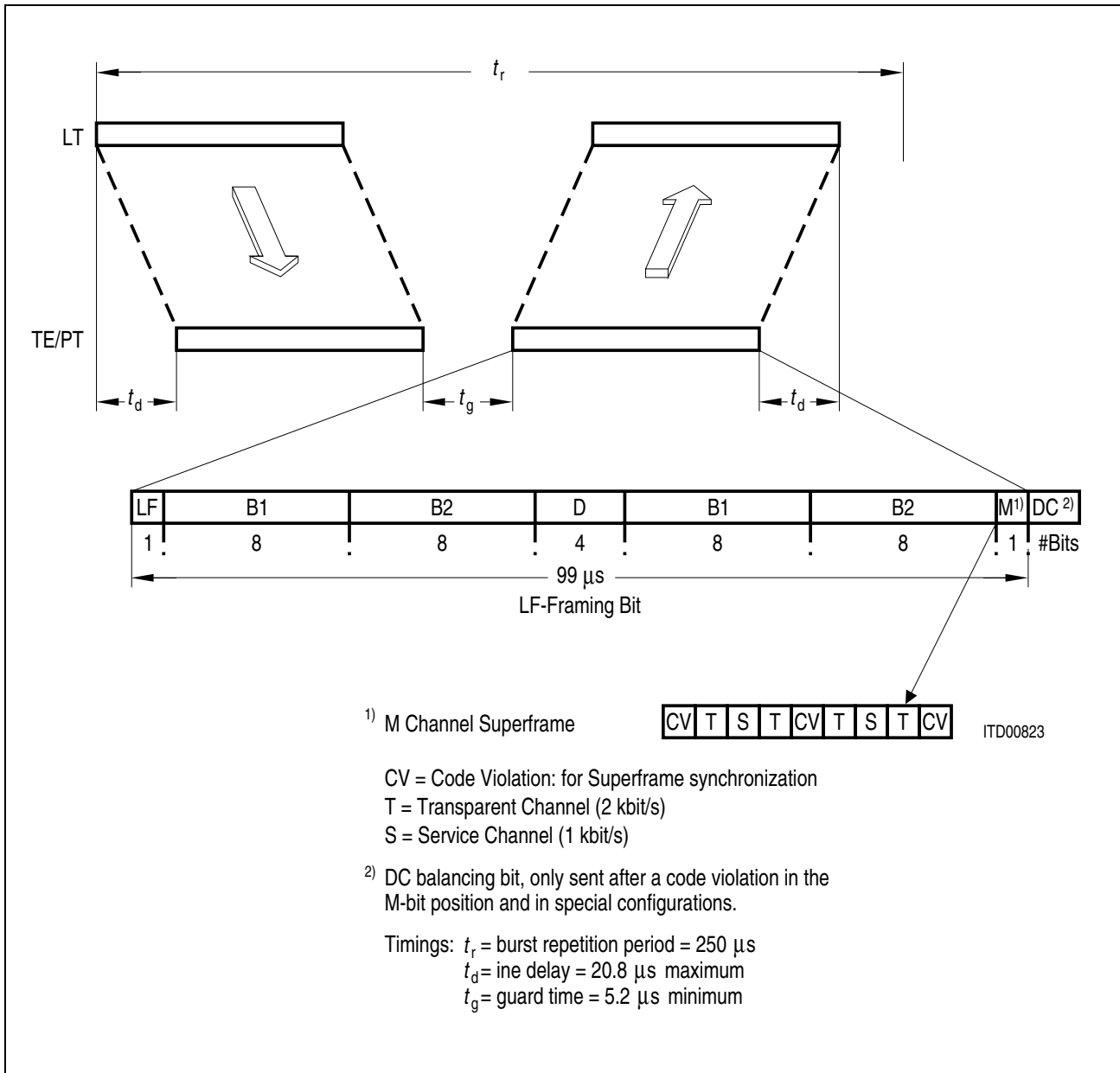

Figure 22 UPN Interface Frame Structure

Up Coding (in VIP)

The coding technique used on the Up interface is a half-bauded AMI code (with a 50 % pulse width (refer to [Figure 23](#)). A logical '0' corresponds to a neutral level, logical '1's are coded as alternate positive and negative pulses. Code violation (CV) is caused by two successive pulses with the same polarity.

The AMI coding includes always the data bits going on the Up interface in one direction. Consequently there is a separate AMI coding unit for data from the DELIC to the VIP implemented in the VIP, and vice versa.

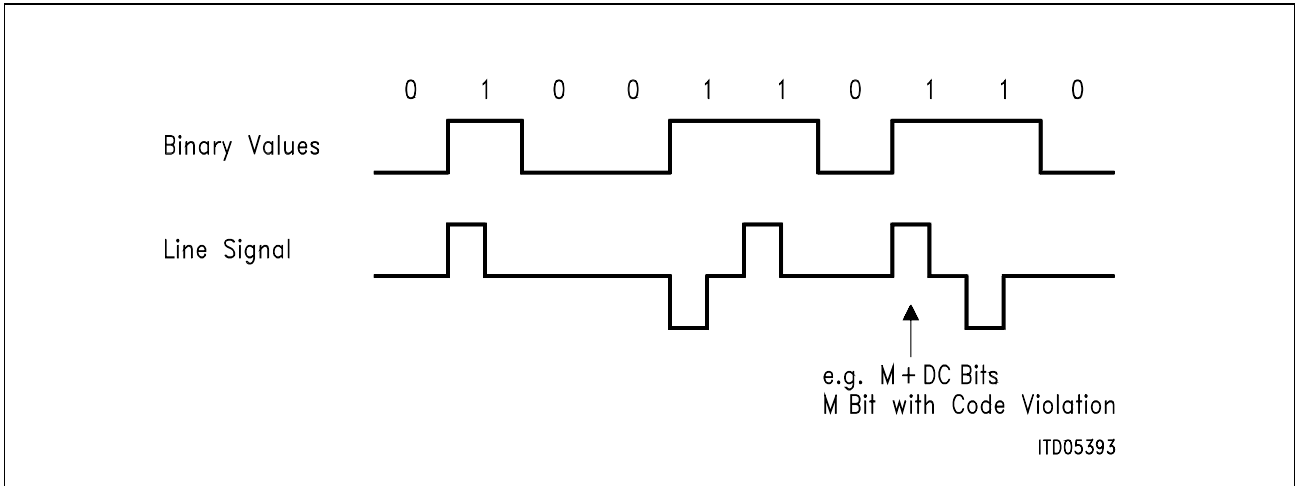

Figure 23 AMI Coding on the Up Interface

4.2.6 U_PN Interface

The data is received and transmitted at a nominal bit rate of 384 kbit/s. In the first half of the 4 KHz frame data is transmitted and 'zeros' are received, in the second half of the frame 'zeros' are transmitted and data is received (Ping-pong interface).

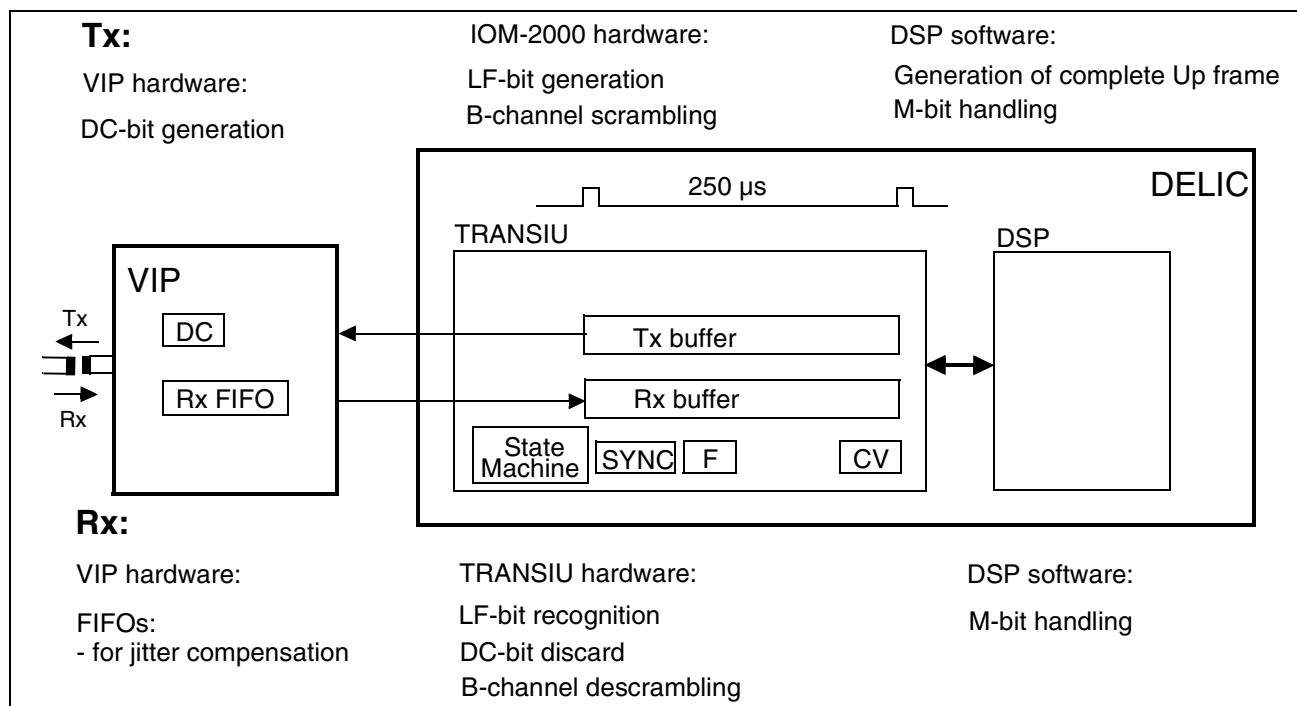

Figure 24 Handling of U_PN Frame (one Channel)

Transmit Direction

- Since the DELIC is always master on the Up-interface, all transmitted Up frames always start with the FSC-2000 (the transmission starts from ch-0.bit-0 which is followed by ch_1.bit_0, ch_2.bit_0,... ch_7.bit_0, ch_1.bit_1, etc.; see also [Figure 12](#))
- The LF-bit is generated and inserted at the beginning of the frame.
- B-channel data prepared by the DSP is scrambled and inserted into the U-frame.
- D-channel data and M-bit, prepared by the DSP, are inserted into the transmitted Up frame by the TRANSIU.

Receive Direction

- The received frame start is recognized by the LF-bit, which is always logical '1' (this is the first '1' received after the FSC_2000). Since the received frames start at different points of time (due to the different line delays) the frame start recognition is performed for each channel separately
- The B-channel data is descrambled
- The B- and D-channel data and M-bit are stored in the Data RAM

4.2.7 U_{PN} Framing Bit Description

4.2.7.1 Framing Bit (LF-Bit)

On the U_{PN} interface the framing (LF) bit is always logical '1'.

In the transmit direction the LF-bit is inserted by the TRANSIU at the beginning of every transmitted U_{PN} frame. The VIP assumes the start of the U_{PN} frame when detecting the first '1' (LF-bit) in the data stream on IOM-2000 DX line together with the 8 kHz IOM-2000 FSC pulse. This is required due to the 8 kHz clock rate of the FSC signal in comparison to the 4 kHz frame length in the U_{PN} interface.

The code violation in the LF position is generated by the VIP when INFO1 is transmitted, according to the DSP command bits SMINI(2:0).

In the receive direction the first '1' recognized on the line after "no signal", which is represented by logical '0', is treated as the LF-bit. The code violation in the LF-bit position is recognized by the VIP when INFO 2 is received. This information is forwarded to the DELIC as part of the VIP receiver status bits RxSTA(1:0).

4.2.7.2 Multiframe Bit (M-Bit)

On the U_{PN} interface multiframe frames are composed of four U_{PN} frames. The multiframe is included at the M-bit position. Every fourth M-bit, a code violation indicates the start of a new multiframe.

In transmit direction, the VIP extracts the multiframe bits out of the IOM-2000 data coming from DELIC and inserts them in the U_{PN} frame at the line side.

In receive direction, the VIP extracts the multiframe bits out of the data coming from the U_{PN} line and inserts them in the IOM-2000 frame to the DELIC.

A multiframe counter in the VIP guarantees the timing of the multiframe. It is synchronized (reset) every 20th U_{PN} frame (=every 40th IOM-2000 frame) by the command bit 'SH_FSC' issued by the DELIC.

Note: The SH_FSC bit performs the functionality of the short FSC pulse in OCTAT-P and QUAT-S.

T-bit

The T-bit received on the U_{PN} line is inserted by the VIP in the IOM-2000 data receive (DR) line at the multiframe (M-bit) position in every frame; i.e. not only at the usual T-bit position every third frame, but also at the S-bit position and the code violation (CV) position. In transmit direction, the T-bit value is sent in the data stream from the DELIC to the VIP, and passed on transparently to the U_{PN} terminal. The T-bit value may be programmed in DELIC's data RAM. It is required e.g. for DECT synchronization.

S-bit

The S-bit received on the U_{PN} line interface is extracted by the VIP out of the data stream, and is logical OR'ed with the detected far-end code violation. The result is sent to the DELIC as status bit 'FECV'.

In transmit direction, the S-bit value is sent in the data stream from the DELIC to the VIP, and passed on transparently to the U_{PN} terminal. The S-bit value may be programmed in DELIC's data RAM. It is required e.g. for switching a digital loop in the terminal.

CV-bit

The code violation bit received on the line is not transmitted to the DELIC.

4.2.7.3 DC-Balancing Bit

A DC-balancing bit is inserted by the VIP according to the Balancing Bit Control (BBC) bit transmitted to the VIP on the command line.

In receive direction, the DC balancing bit is received, but not evaluated.

4.2.7.4 U_{PN} Mode Data Format

The data is received and transmitted at a nominal bit rate of 384 kbit/s. In the first half of the 4 kHz U_{PN} frame data is transmitted and 'zeros' are received, in the second half of the frame 'zeros' are transmitted and data is received.

Scrambling and de-scrambling of the B-channel data is done automatically. The received and transmitted data is stored in the Data RAM in the following format:

U_{PN} Mode Receive / Transmit Data Format

7	6	5	4	3	2	1	0
B1-channel data							
B2-channel data							
D-channel	M-bit	x	x	x	x	x	x
Operation Mode Command/Status bits							

In transmit direction, depending on the multiframe position, the M-bit contains either the T-bit or the S-bit with the following functionality:

- T-bit: a) D-channel available info to the terminal
b) DECT synchronization signal
- S-bit: switches remote loop in terminal device

4.2.7.5 U_{PN} Scrambler/Descrambler

B-channel data on all U_{PN} channels of the IOM-2000 interface is scrambled to give a flat continuous power density spectrum on the line.

Scrambling is done according to ITU-T V.27 with the generator polynomial $1 + x^6 + x^7$, OCTAT-P and DASL.

Initialization via History RAM (HRAM)

The scrambler is activated/deactivated for each U_{PN} channel separately by a DSP write to the history RAM address.

During initialization the DSP writes a value with '0' in its LSB (other bits are of no importance) to every History RAM address associated to an U_{PN} channel that is not to be scrambled, and a value with '1' in its LSB for every U_{PN} channel that must be scrambled. The same values must be written to the descrambler history RAM.

The HRAM addresses are:

- 0x9000 - 0x9017 (scrambler U_{PN} channel 0..23)
- 0x9020 - 0x9037 (descrambler U_{PN} channel 0..23)

For example, in order to activate scrambling and descrambling for channel number 3, the DSP must execute two write operations as follows:

- Write "xxxxxxxxxxxxxxxx1" to address 0x9002
- Write "xxxxxxxxxxxxxxxx1" to address 0x9022

These writes are executed only when the scrambler is in idle mode, i.e. value 0x0003 was written by the OAK to address 0xD010.

Note: The HRAM setting is handled by the DSP according to the scrambler mode register (address 0xD010).

4.2.8 DECT Synchronization for U_{PN}- Interface

For DECT systems the DELIC supports synchronization of the different radio base stations (RBS). Synchronization is controlled by the DSP via the T-bit in the U_{PN}-frame.

4.2.9 S/T Interface Frame Structure

The S/T interface establishes a direct link between the VIP and connected subscriber terminals or to the Central Office. It consists of two pairs of copper wires: one for the transmit and one for the receive direction.

Direct access to the VIP's S/T interface by the DELIC is not possible. 2B+D user data as well as S/Q channel information can be inserted and extracted via the IOM-2000 interface.

Framing bits are generated and transmitted to the VIP by the DELIC.

Transmission over the S/T interface is performed at a rate of 192 kbit/s. Pseudo-ternary coding with 100 % pulse width is used. 144 kbit/s are used for user data (36 bits of B1+B2+D) and 48 kbit/s (12 bits) are used for framing, S/Q and maintenance information. For each S/T channel, the VIP uses two symmetrical, differential outputs (SX1, SX2) and two symmetrical, differential inputs (SR1, SR2). These signals are coupled via external circuitry and two transformers onto the 4 wire S/T interface. The nominal pulse amplitude on the S/T interface is 750 mV (zero-peak).

S/T Coding

The following figure illustrates the code used. A binary ONE is represented by no line signal (0 V). Binary ZEROs are coded with alternating positive and negative pulses with two exceptions: the first binary ZERO following the framing balance bit is of the same polarity as the framing-balancing bit, and the F-bit is always at positive level (required code violations).

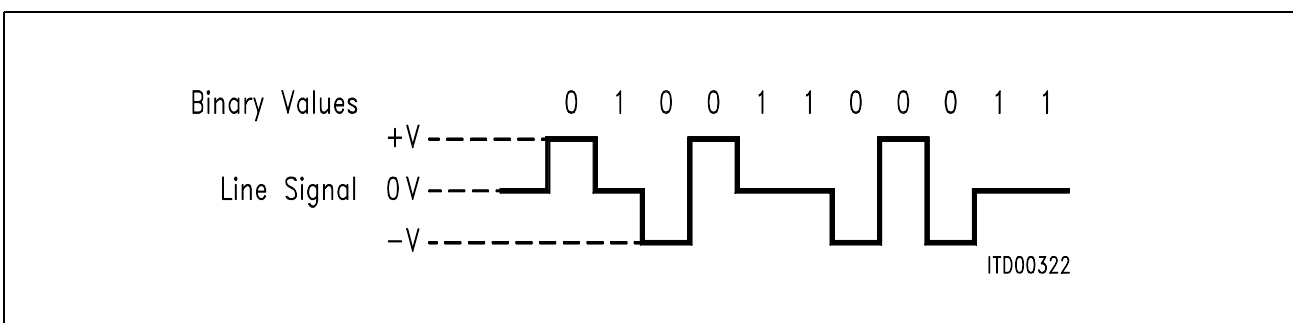

Figure 25 S/T Interface Line Code (without code violation)

A standard S/T frame consists of 48 bits. In the direction TE →NT the frame is transmitted with a 2-bit offset. For details on the framing rules please refer to ITU I.430. The following figure illustrates the standard frame structure for both directions (NT →TE and TE →NT) with all framing and maintenance bits.

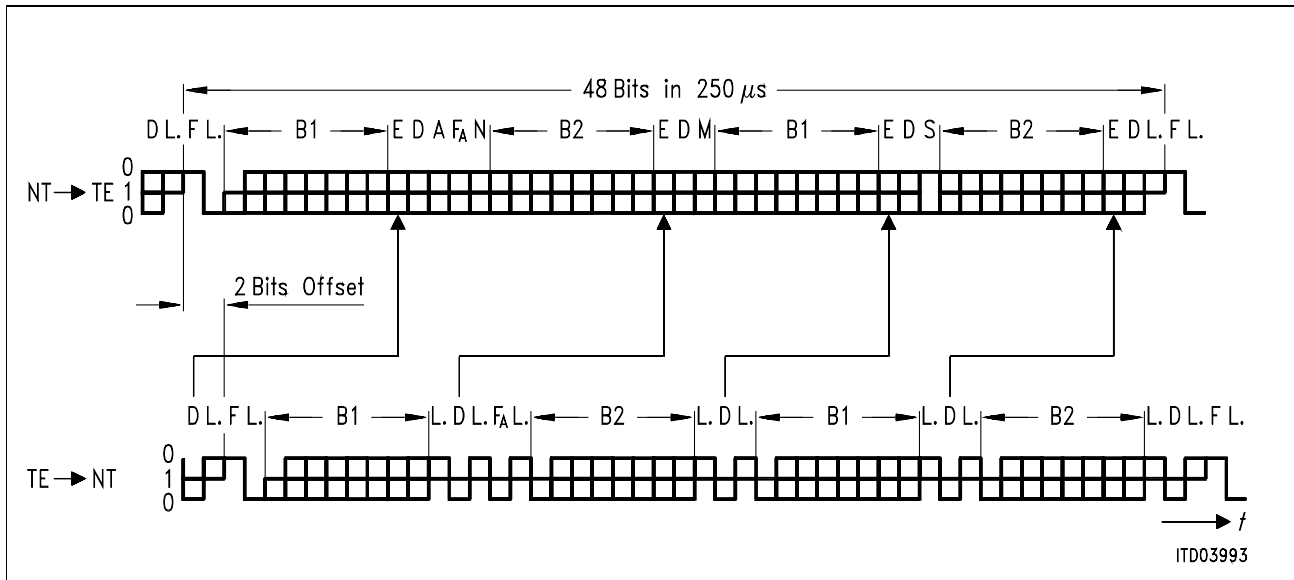

Figure 26 Frame Structure at Reference Points S and T (ITU I.430)

– F	Framing Bit	F = (0b) →code violation, identifies a new frame (always positive pulse)
– L.	D.C. Balancing Bit	L. = (0b) →number of binary ZEROs sent after the last L. bit was odd
– D	D-Channel Data Bit	signaling data specified by user
– E	D-Channel Echo Bit	E = D if D-channel is not blocked, otherwise E = \overline{D} . (ZEROs always overwrite ONES)
– F _A	Auxiliary Framing Bit	See section 6.3 in ITU I.430
– N		N = $\overline{F_A}$
– B1	B1-Channel Data Bit	User data
– B2	B2-Channel Data Bit	User data
– A	Activation Bit	A = (0b) →INFO 2 transmitted A = (1b) →INFO 4 transmitted
– S	S-Channel Data Bit	S ₁ or S ₂ channel data
– M	Multiframing Bit	M = (1b) →Start of new multi-frame

In LT-T configurations, the DELIC receives the reference clock from the Central Office via the IOM-2000 REFCLK line. The VIP selects the reference clock source via two multiplexers. The source may be either one of the 8 VIP channels operated in LT-T mode or the CLKIN pin when driving multiple cascaded VIPs on the IOM-2000.

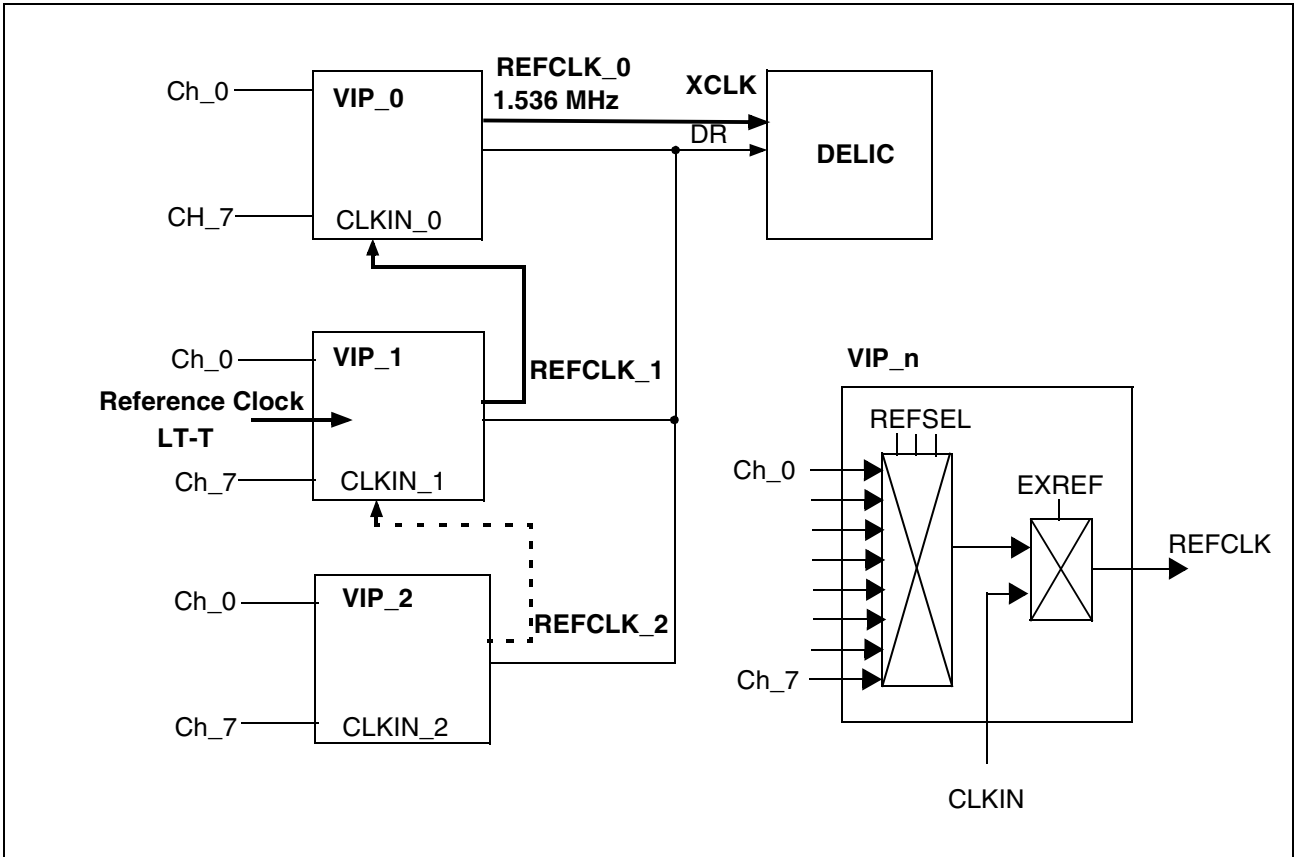

Figure 27 Reference Clock Selection for Cascaded VIPs on IOM-2000

Note: A change in the reference clock source must not result in a FSC jump greater than the difference of the clock phase before and after the change, which otherwise would result in big frame slips.

4.2.9.1 LT-S mode

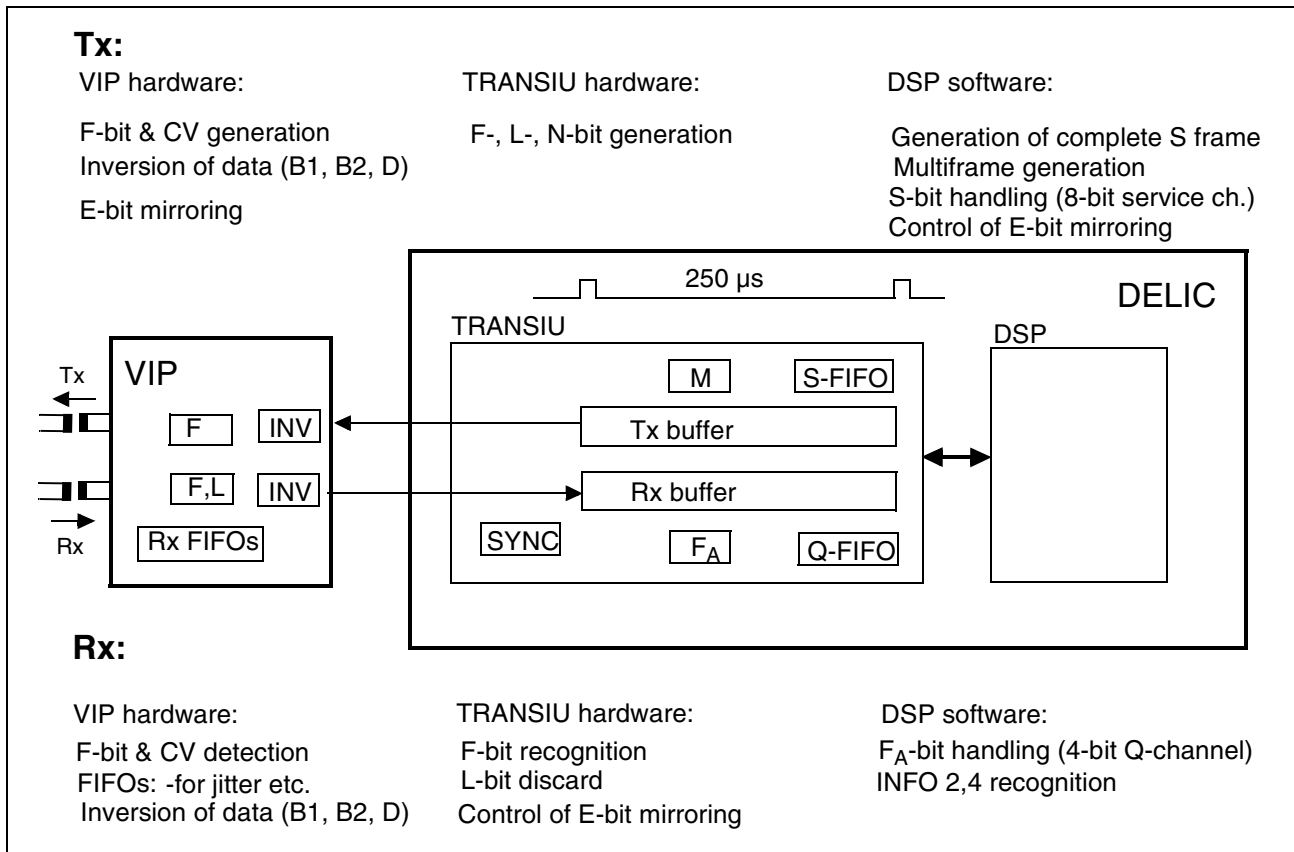

Figure 28 Handling of So Frame in LT-S Mode (One Channel)

Transmit Direction

- Since the DELIC is master in the LT-S mode, all transmitted frames always start with the FSC-2000 (the transmission starts from ch_0.bit_0 which is followed by ch_1.bit_0, ch_2.bit_0,... ch_7.bit_0, ch_0.bit_1, etc.; see also [Figure 12](#))
- The F-, L- and N-bits are generated and inserted into the S/T frame
- The information about D-channel availability is transmitted at the E-bit position
- The B- and D-channel data, A-, F_a-, M- and S-bits are prepared by the DSP and inserted into transmitted S/T frame by the IOM-2000

Receive Direction

- The received frame start is recognized by the F-bit. Since the received frames start at different points of time (due to the different line delays) the frame start recognition is performed for each channel separately
- The received L-bits are discarded
- The B- and D-channel data bits and F_a-bit are arranged in the Data RAM

D-echo Bit Generation in LT-S Mode

In the LT-S mode, the last received D-bit has to be reflected in the next available E-bit ($E=D$). If there are no HDLC controllers available, the D-channel is blocked ($E=\bar{D}$ is transmitted). Since it is necessary to meet the ITU requirement to react immediately (i.e., even when line delays of several bits have occurred) upon the reception of a D-bit by issuing the E-bit, the E-bit has to be inserted by the VIP. The information about the D-channel availability is provided to the VIP in the E-bit data field.

Table 28 D-Echo Bit

bit0 (data)	bit1(control)	
0	0	The transmitted E-bit is equal to the received D-bit
1	0	The transmitted E-bit is equal to the inverted received D-bit

Information about the availability of HDLC controllers is provided to the IOM-2000 by the DSP.

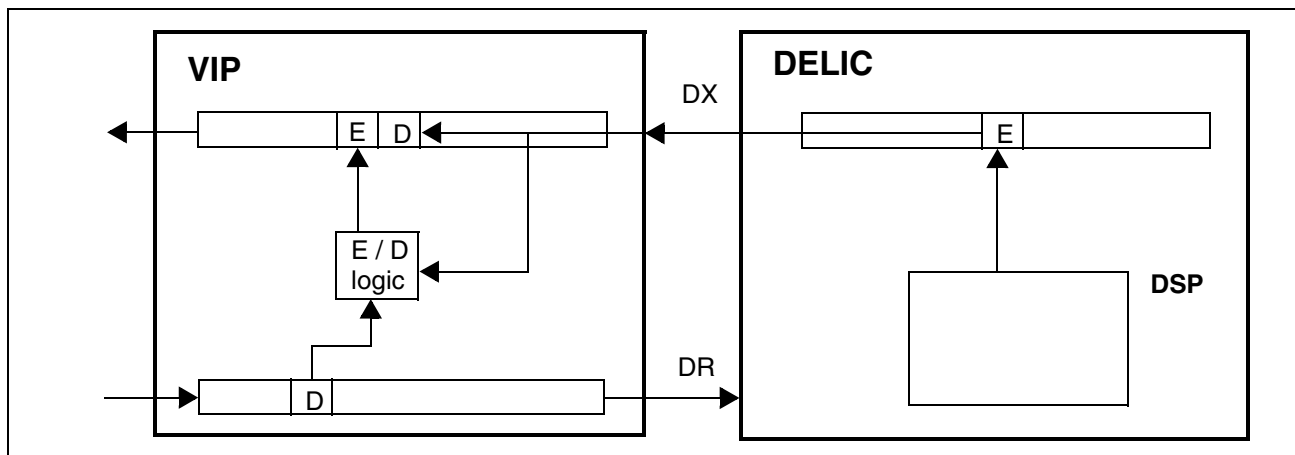

Figure 29 D-Echo Bit Generation

4.2.9.2 LT-T Mode

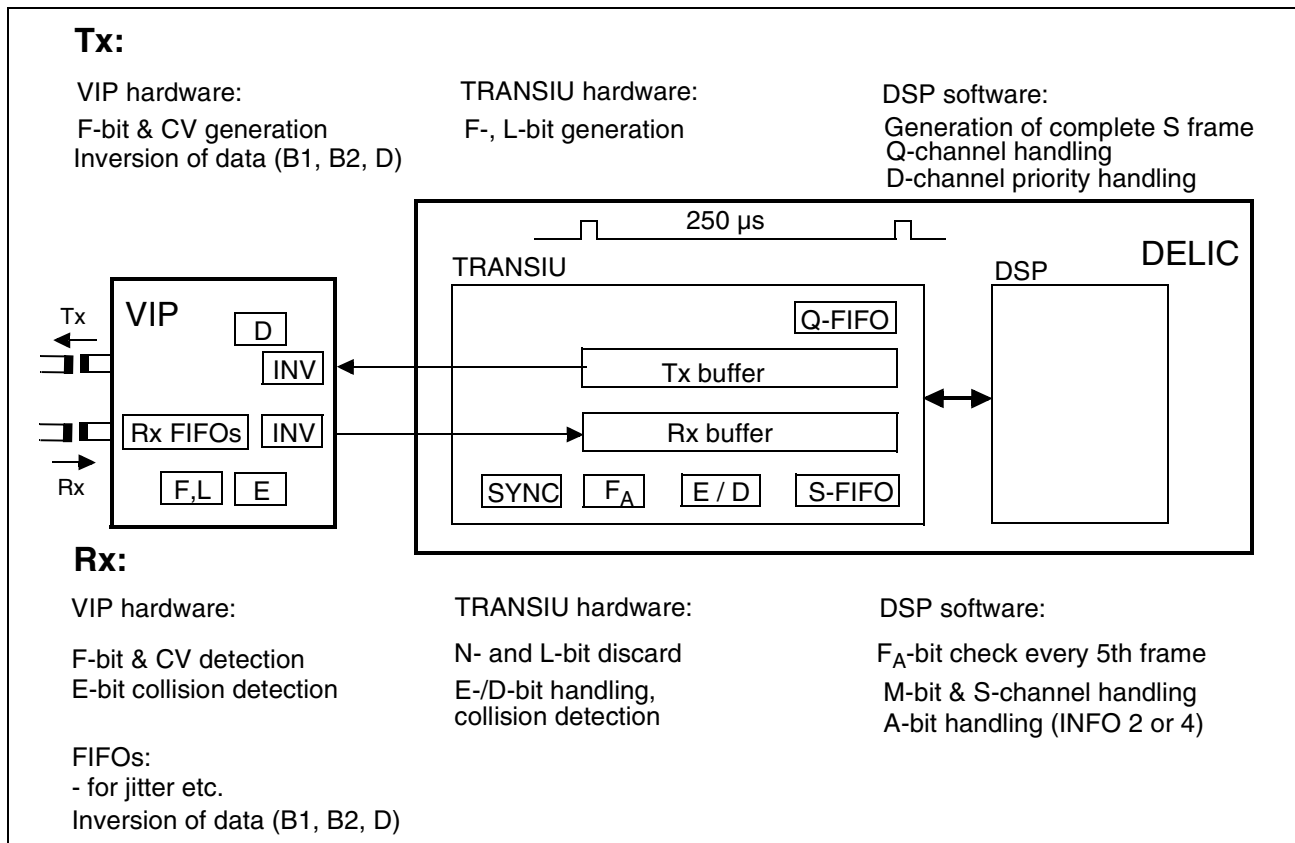

Figure 30 Handling of So Frame in LT-T Mode (One Channel)

Receive Direction

- The received frame start is recognized by the F-bit. Since the DELIC is a slave in the LT-T mode, the received frames may start at any point of time, and the frame start recognition is performed for each channel independently.
- The received L- and N-bits are discarded
- The received E-bit is compared with the last transmitted D-bit—if collision is detected on the D-channel it is reported to the DSP
- The received B- and D-channel data bits, A-, F_a-, M- and S-bits as well as the information about collision detected on the D-channel are stored in the Data RAM.

Transmit Direction

- According to ITU.430, the 2-bit delay between received and transmitted frames must be guaranteed at the TE (i.e., this delay must be controlled by the VIP). Because of the VIP delay in both receive and transmit directions (this delay is the same for all LT-T lines and is always constant (TBD during VIP design)), the TRANSIU starts the LT-T frame transmission before the F-bit of received frame is recognized.
- The F- and L-bits are generated and inserted into the S/T frame

Functional Description

- The B-channel data is prepared by the DSP in the Data RAM and inserted into the downstream frame by the TRANSIU
- If collision was detected on the D-channel, the data transmission on this channel is blocked by the TRANSIU and the 1's are sent on the D-channel instead of the data from the Data RAM until the data sending is enabled by the DSP
- The B- and D-channel data bits and F_a -bit are prepared by the DSP in the Data RAM in the same format as LT-S received frames

Collision Detection on D-channel in LT-T Mode

The collision is detected on the D-channel when the received E-bit is not equal to the last transmitted D-bit.

- The TRANSIU compares the E-bit with the D-bit
- When the collision is detected, the TRANSIU indicates collision to the DSP, and starts to send 1's on the D-channel.
- The priority mechanism is implemented in software. The TRANSIU provides the following information to the DSP (2 bits per LT-T – configured channel, which are stored in the Data RAM, see **“LT-T Mode Receive Data Format” on Page 94**.
 - Collision detection on D-channel (CI-bit): '0' – no collision in the D-channel, '1' – collision was detected in the D-channel.
 - Collision detection bit number: '0' – collision was detected in the 1-st bit of the frame, '1' – collision was detected in the 2-nd bit of the frame.
- The DSP counts to 8/9 (higher priority) or 10/11 (lower priority) and enables the TRANSIU to transmit the data on the D-channel at the end of counting. The TRANSIU stops D-channel blocking immediately, all relevant data (end of Idle or start of the flag) is already prepared by the DSP in the Data RAM.
- If the new collision was detected by the TRANSIU during the current collision, the DSP resets the priority mechanism counters and starts counting from the beginning.

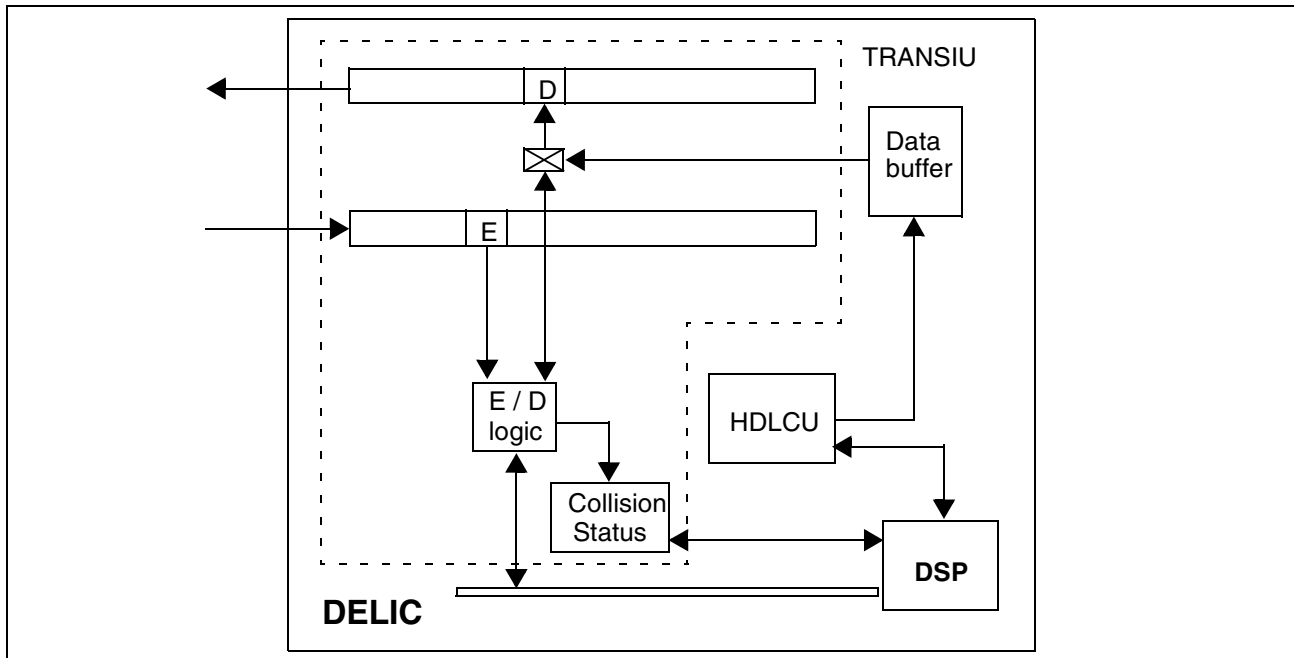

Figure 31 Collision Detection in the LT-T Mode

4.2.10 S/T Mode Control and Framing Bits on IOM-2000

4.2.10.1 Framing Bit (F-Bit)

The framing (F) bit is recognized on the TRANSIU interface, when both data and control bits are equal to '1'. In the transmit direction the data and control bits are inserted by the TRANSIU at the beginning of every transmitted frame; in the receive direction the framing bit is used for frame start recognition.

4.2.10.2 Multiframing Bits

In S/T interface, the multiframe includes 20 S/T frames. The start of a multiframe is indicated by the M- and F_a -bits (the M-bit is set to '1' in every 20th frame, the F_a -bit is set to '1' in every 5th frame).

The S/Q channel provides the additional capability for data exchange between LT-S and TE or between the Central Office (CO) and the LT-T at the multiframe level. In the LT-S-to-TE direction the S-channel (S-bit in S/T frame) is used. In the opposite direction (TE to LT-S) the data is transferred on the Q-channel. The Q-bits are defined to be the bits in the F_a bit position of every 5th frame. The Q-bit position is identified by $F_a = '1'$ in the TE to LT-S direction. A multiframe is provided for structuring the Q-bits in groups of four (Q1-Q4).

The Q- and S-channel coding with respect to the frame number is shown in [Table 29](#).

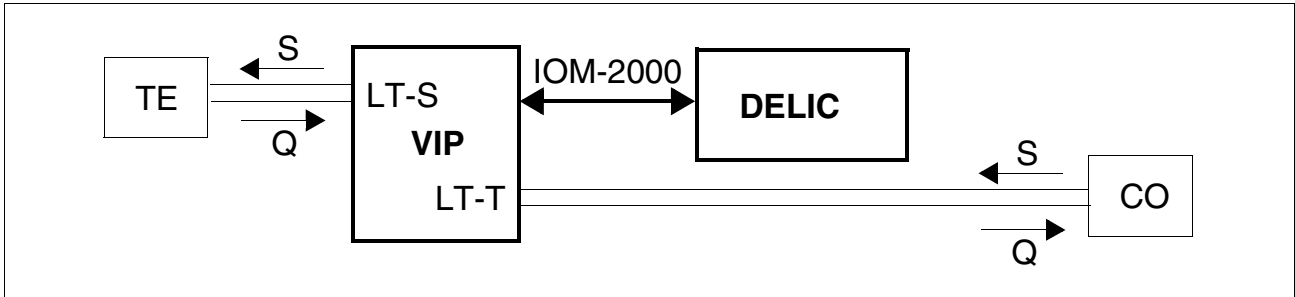

Figure 32 S/Q Channel Assignment

Table 29 S/T Mode Multiframe Bit Positions

Frame number	LT-S to TE or CO to LT-T, F_a bit position	LT-S to TE or CO to LT-T, M-bit	LT-S to TE or CO to LT-T, S-bit	TE to LT-S or LT-T to CO F_a bit position
1	1	1	S11	Q1
2	0	0	S21	0
6	1	0	S12	Q2
7	0	0	S22	0
11	1	0	S13	Q3
12	0	0	S23	0
16	1	0	S14	Q4
17	0	0	S24	0
...

*Note: 1. Only frame positions (within the 20-frame multiframe) that carry S- or Q-channel information are shown here
2. The Q- and S-bits, which are not used, are set to '1'.*

On the IOM-2000 interface, the S/T multiframe information is included in the DX/DR data stream (transparent to the VIP). The values of the multiframe are controlled by the DSP software in the DELIC.

When multiframe synchronization is not achieved or lost, the VIP mirrors the received F_a bits. Once the multiframe synchronization is established, the DSP sends the multiframe synchronization command to the VIP (MSYNC bit). Upon reception of the MSYNC, the VIP stops mirroring the F_a -bit.

4.2.10.3 F_a/N Bit

In the transmit direction the F_a/N bit pair is coded in such a way that N is the binary opposite of the F_a . The F_a bit is equal to binary '0', except every 5th frame when it is set to '1', which indicates the Q-bit position to the TE.

The receive direction, the F_a bit positions represent the Q-channel.

4.2.10.4 DC-Balancing Bit (L-Bit)

In transmit (downstream) direction the L-bit is generated in compliance with ITU-T I.430:

- A balance bit is '0' if the number of 0's following the previous balance bit is odd.
- A balance bit is '1' if the number of 0's following the previous balance bit is even.

It is inserted by the VIP according to the Balancing Bit Control (BBC) bit sent to the VIP by the DELIC via the CMD line.

In receive (upstream) direction, the DC balancing bit is received on the line, but not evaluated.

4.2.11 IOM-2000 Data Interface

Data processing and frame handling in the TRANSIU is fully DSP controlled. Serial data received and transmitted on the TRANSIU Interface is arranged in the Shift Receive RAM and Shift Transmit RAM.

The DSP processed bytes are stored in the TRANSIU Current Buffer. Every 8 kHz frame the TRANSIU and DSP Current Buffers are switched.

4.2.11.1 S/T Mode Data Format

Data is received/transmitted at a nominal rate of 192 kbit/s. Each S/T data bit is translated into two bits on IOM-2000: data (bit0) and control (bit1).

LT-S Mode Transmit Data Format

7	6	5	4	3	2	1	0
B1-channel data							
B2-channel data							
D-channel	x	F _a	M	S	x	x	
Operation Mode Command/Status bits							

LT-S Mode Receive Data Format

7	6	5	4	3	2	1	0
B1 - channel data							
B2 - channel data							
D-channel	F _a	x	x	x	x	x	
Operation Mode Command/Status bits							

LT-T Mode Transmit Data Format

7	6	5	4	3	2	1	0
B1-channel data							
B2-channel data							
D-channel	F_a	x	x	x	x	x	x
Operation Mode Command/Status bits							

LT-T Mode Receive Data Format

7	6	5	4	3	2	1	0
B1-channel data							
B2-channel data							
D-channel	x	F_a	M	S	CBN	CDI	
Operation Mode Command/Status bits							

CBN Collision Detection Bit Number
 0 = Collision was detected in the first D-bit of the S-frame half
 (corresponds to the second echo-bit of the frame half)
 1 = Collision was detected in the second D-bit of the S-frame half
 (corresponds to the first echo-bit of the frame half)

CDI Collision Detection Indication
 0 = No collision in D-channel
 1 = Collision in D-channel detected

4.2.12 Test Loop

The DELIC/VIP allows to set up internal as well as remote loops for testing by programming registers TICCMR and TUTRL.

Note: Please refer also to the Application Note 'Test Loops in the VIP'.

4.3 IOM-2 Unit

4.3.1 IOMU Features

The IOMU provides the DSP access to incoming time slots from the IOM-2 interface.

Features

- DSP access for switching of B1 and B2 data to the PCMU, TRANSIU and IOMU (providing a constant switching delay of two 8 kHz frames)
- DSP access for extracting D-channel information
- DSP access for control of IOM-2 Command/Indication (C/I) and Monitor channel information

Interface Configuration

- Two IOM-2 ports providing up to 16 IOM-2 channels (up to 16 ISDN or 32 analog subscribers)
- Available data rate modes:
 - One port of 384 kbit/s each (1 x 6 time slots per frame)
 - One port of 768 kbit/s each (1 x 12 time slots per frame)
 - Two ports of 2.048 Mbit/s each (2 x 32 time slots per frame)
 - One port of 4.096 Mbit/s (1 x 64 time slots per frame)
- Single or double data rate clock selectable for data rates up to data rates up to 2.048 Mbit/s
- Programmable tri-state control for each port and channel (=4 time slots)
- Push-pull or open-drain configuration
- DRDY signal for D-channel control when connected to QUAT-S PEB 2084

4.3.2 IOMU Functional and Operational Description

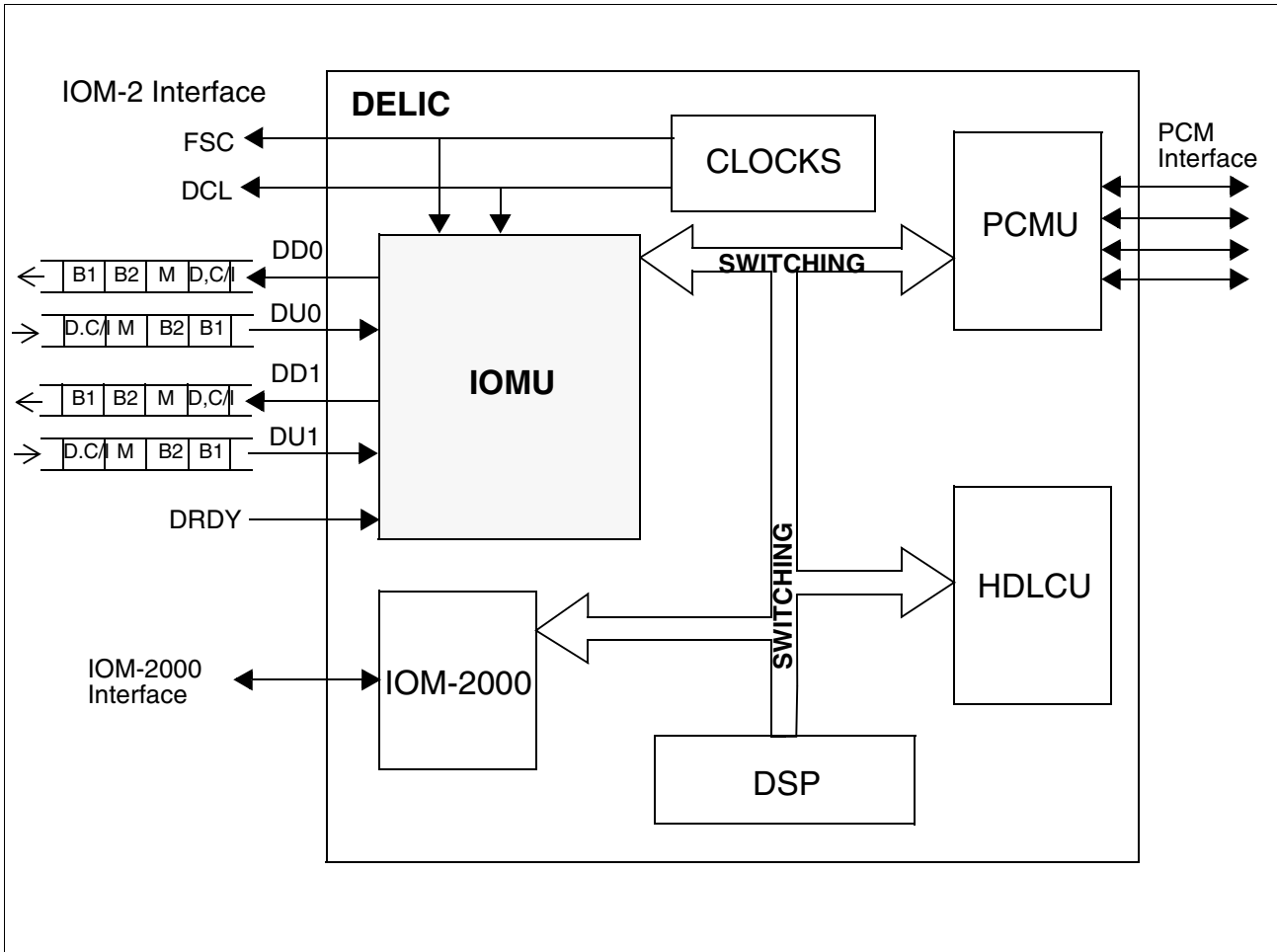

Figure 33 IOMU Integration in DELIC

4.3.2.1 Frame-Wise Buffer Swapping

The main task of the IOMU is the serial-to-parallel conversion of incoming IOM-2 data to a parallel data format which is directly read by the DSP. This access is required for the DSP to perform switching of B-channels, extraction of D-channels, and layer-1 control via the IOM-2 C/I and Monitor channels.

The data conversion in the IOMU is done by frame-wise swapping based on a circular buffer structure. During each 8 kHz frame, one buffer is assigned to the IOMU (I-buffer), and the other one to the DSP (D-buffer). At the end of every frame, the buffers are swapped.

4.3.2.2 DSP Inaccessible Buffer (I-buffer) Logical Structure

The logical partitioning of each frame buffer into input and output blocks is determined according to the requested data rate as shown in the table below.

Table 30 I-Buffer Logical Memory Mapping

Data Rate	Input Blocks		Output Blocks	
	in0	in1	out0	out1
2 x 2.048 Mbit/s	00 _H - 1F _H	20 _H - 3F _H	40 _H - 5F _H	60 _H - 7F _H
1 x 384 kbit/s	00 _H - 05 _H	--	40 _H - 05 _H	--
1 x 768 kbit/s	00 _H - 0B _H	--	40 _H - 4B _H	--
1 x 4.096 Mbit/s	00 _H - 3F _H	--	40 _H - 7F _H	--

4.3.2.3 DSP Access to the D-Buffer

The D-buffer is mapped to a fixed DSP address space. Every DSP access to the D-buffer space is directed automatically to the appropriate sub-buffer. E.g. the address of time slot 5 is 0x8005 in receive and 0x8045 in transmit direction.

Table 31 D-Buffer Address Space

Data-Rate Mode	D-Buffer			
	in0	in1	out0	out1
2 x 32 time slots/frame	8000 _H - 801F _H	8020 _H - 803F _H	8040 _H - 805F _H	8060 _H - 807F _H
1 x 6 time slots/frame	8000 _H - 8005 _H	-	8040 _H - 8045 _H	-
1 x 12 time slots/frame	8000 _H - 800B _H	-	8040 _H - 804B _H	-
1 x 64 time slots/frame	8000 _H - 803F _H	-	8040 _H - 807F _H	-

4.3.2.4 Circular Buffer Architecture

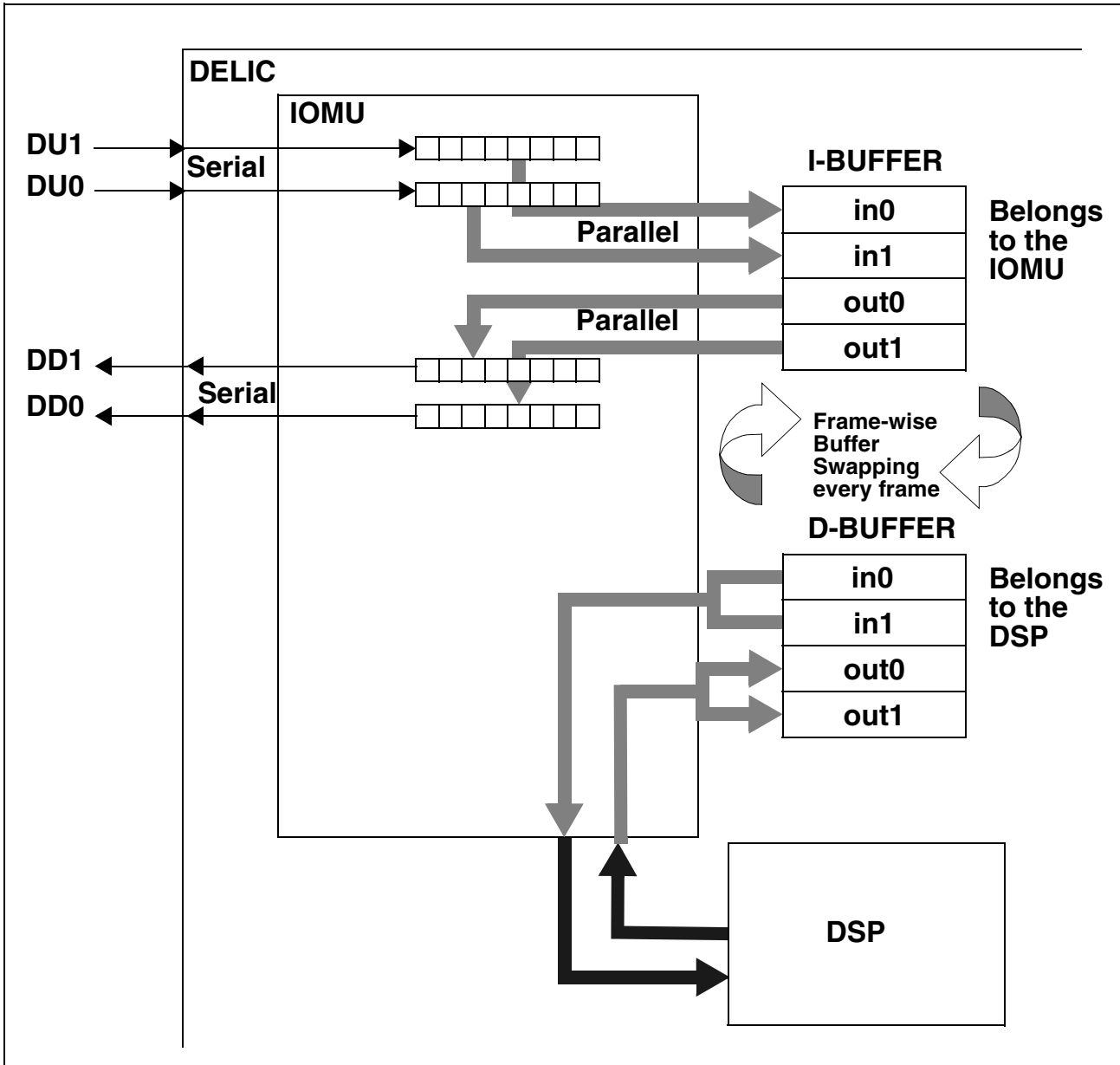

Figure 34 IOMU Frame-Wise Circular-Buffer Architecture

The following description analyses the frame-wise circular-buffering scheme, on a frame to frame basis.

Assume that during frame n , buffer-0 is used as I-buffer, while buffer-1 is used as D-buffer. The IOMU stores the incoming frame- n time-slots in buffer-0 input-blocks and drives outward the frame n time-slots which are read from buffer-0 output-blocks. At the same time the DSP reads the time-slots that arrived during frame $n-1$ (the previous frame) from buffer-1 input-blocks and prepares the time-slots to be driven outward in the next frame, frame $n+1$, in buffer-1 output blocks.

Functional Description

A buffer-swapping takes place at the end of frame-n, as at the end of any other frame. This means that during frame-n+1, buffer-1 is used as I-buffer, while buffer-0 is used as D-buffer. During this frame the IOMU handles the incoming and outgoing frames n+1, and writes/reads the time-slots to/from buffer-1 input/output blocks. In parallel, the DSP handles buffer-0 input and output blocks. It reads the frame-n up-stream time-slots from the input-blocks and prepares the frame-n+2 down-stream time-slots in the output blocks. The buffer-swapping at the end of frame-n+1 re-assigns buffer-0 as the I-buffer and buffer-1 as the D-buffer (exactly as in frame-n).

Figure 35 illustrates the frame-wise circular-buffering scheme during two consecutive frames, as described in the previous example.

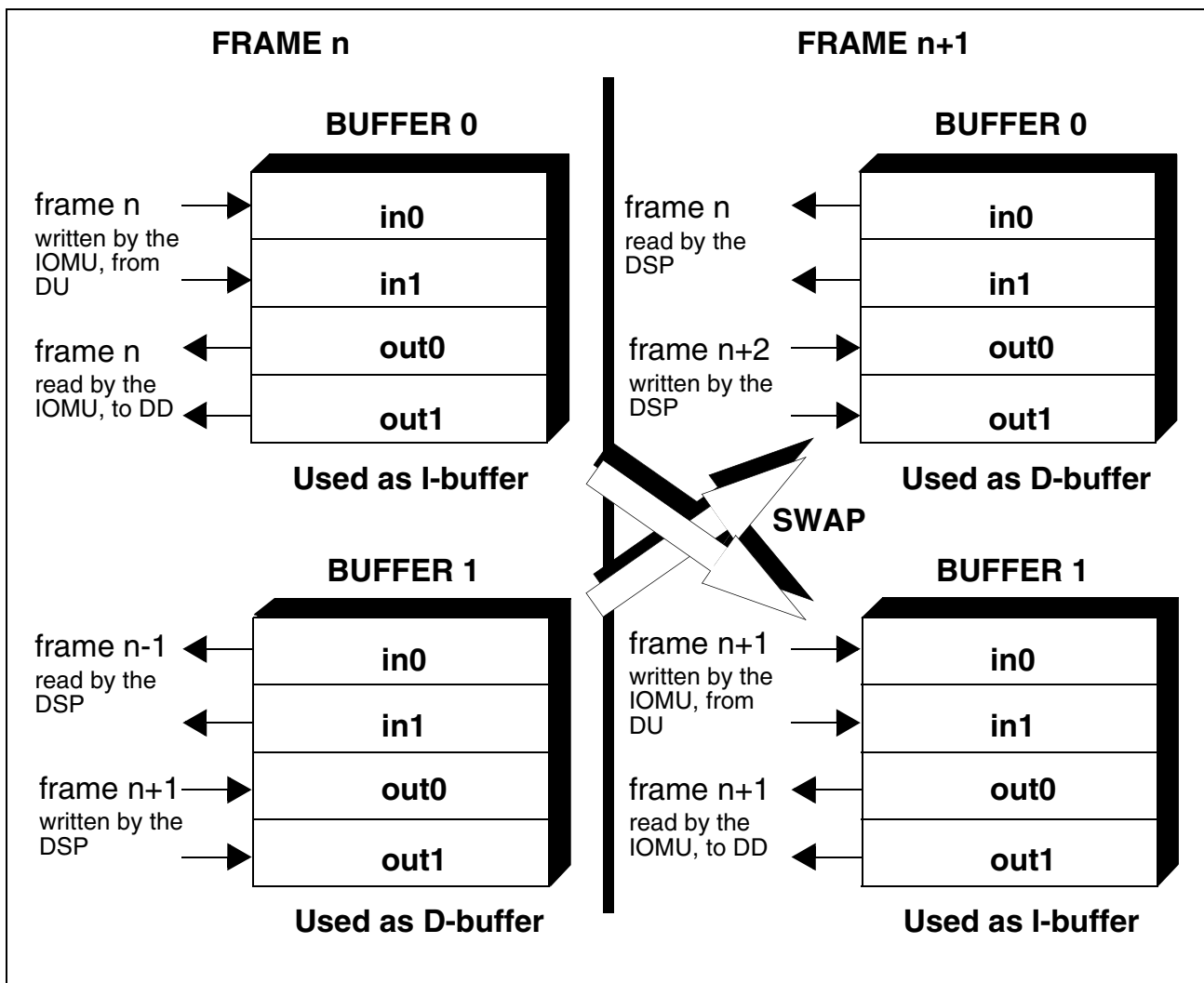

Figure 35 The Circular-Buffer During two Consecutive Frames

4.3.2.5 IOM-2 Interface Data Rate Modes

The IOMU may support different serial data rates of the IOM-2 interface:

- 384 kbit/s (6 time slots per frame)
- 768 kbit/s (12 time slots per frame)
- 2.048 Mbit/s (32 time slots per frame = 8 IOM-2 channels per frame)
- 4.096 Mbit/s (64 time slots per frame = 16 IOM-2 channels per frame)

The IOMU circular buffer may handle up to 64 time slots per frame. Thus, when in 4.096 Mbit/s mode, only IOM-2 port 0 is used. In this case IOM-2 port 1 remains in IDLE mode, i.e. the DD1 output pin is tri-stated.

Table 32 DCL Frequency in Different IOM-2 Modes

Single/Double Rate DCL Mode	IOM-2 Mode			
	1x384 kbit/s	1x768 kbit/s	2x2.048 Mbit/s	1x4.096 Mbit/s
Single	384 kHz	768 kHz	2.048 MHz	4.096 MHz
Double	768 kHz	1536 kHz	4.096 MHz	-

The IOMU meets the IOM-2 interface timing specifications as described below.

Single Data Rate DCL Mode

- Serial transmission via DD0/DD1 with every DCL rising edge
- Sampling of the incoming serial data (DU0/DU1) with every DCL falling edge
- Sampling FSC with every DCL falling edge. Sampling of FSC = 1 after sampling of FSC = 0 is considered to be the start of a frame.

Double Data Rate DCL Mode

- Two DCL cycles per bit (the bits are aligned to the frame start)
- Serial transmission via DU0/1 with every second DCL rising edge.
- Sampling of incoming serial data (DD0/1) with the second DCL falling edge of each bit.
- Sampling of FSC every DCL falling edge. Sampling of FSC = 1 after sampling of FSC = 0, is considered to be the start of a new frame.

Figure 36 shows the IOM-2 interface timing with single and double rate DCL.

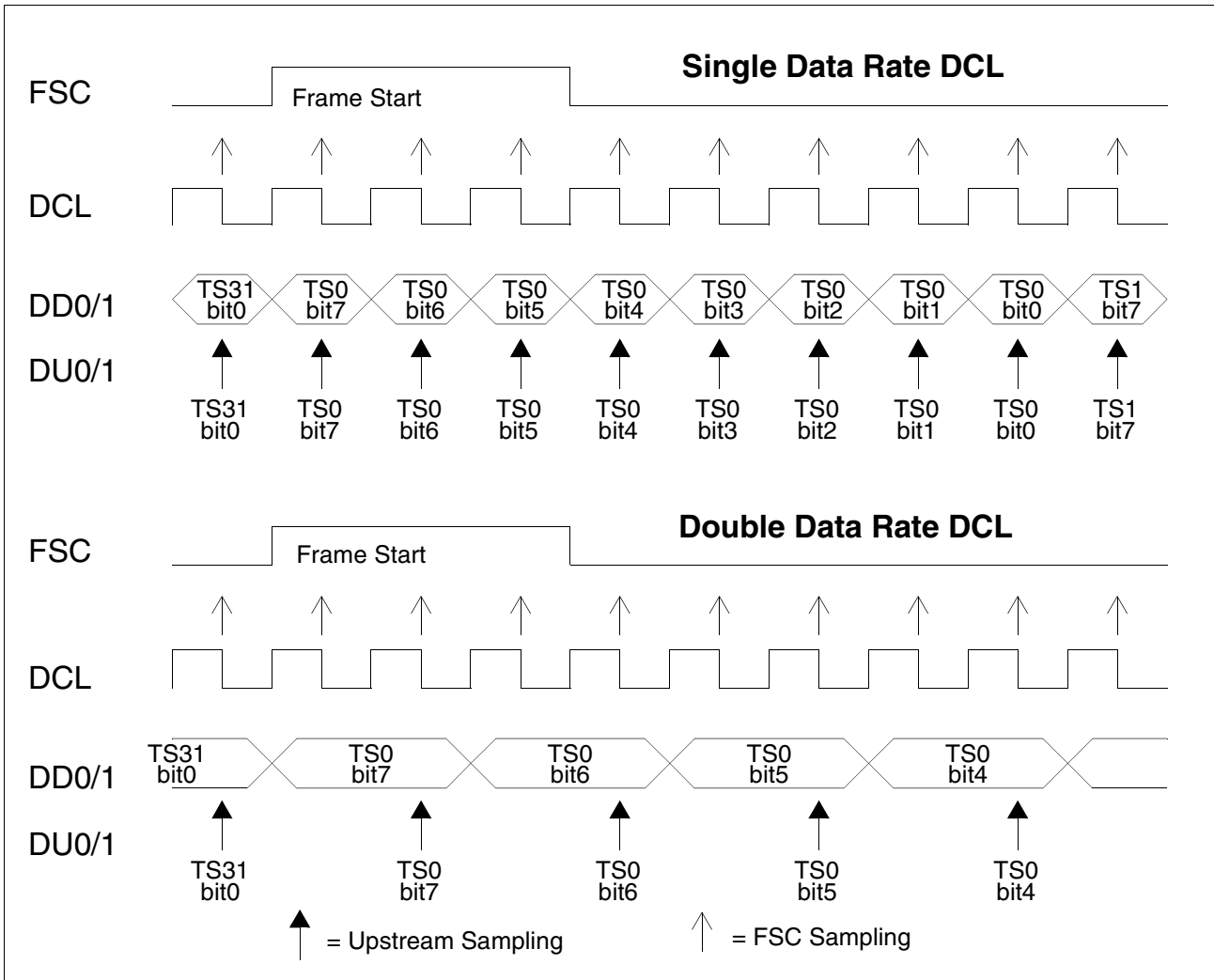

Figure 36 IOM-2 Interface Timing in Single/Double Clock Mode

4.3.2.6 IOMU Serial Data Processing

The IOMU serial data processing is according to the IOM-2 specifications. Incoming serial data is converted into parallel bytes, and stored in the I-buffer input blocks. The sequence for every time slot received is from MSB (bit 7) to LSB (bit 0). Transmission is performed in the opposite direction, from MSB (bit 7) to LSB (bit 0).

4.3.2.7 IOMU Parallel Data Processing

The data read from the IOMU frame buffers by the DSP always reside in the low byte of the 16-bit word. The high byte of the read word is driven by the 8-bit IOMU Data Prefix Register (IDPR). The data prefix is used to accelerate the A- μ -law to linear conversions (refer to [Chapter 4.5](#)).

Note: Any octet written by the DSP to any location in the IOMU frame buffers should reside in the low byte (8 LSB). The high byte of the written word is "don't care".

4.3.2.8 IOM-2 Push-Pull and Open-Drain Modes

The IOM-2 ports can be configured to Push-Pull or Open-Drain modes by a dedicated bit in the IOMU Control Register. When programmed to Open-Drain, DD0/DD1 is tri-stated when a '1' is supposed to be transmitted, or during a time slot quadruplet with the associated Tri-State Register bit set.

In both cases the external pull-up resistor, which is used when working in open-drain mode, will “pull” the value to '1'.

Note: When the IOMU is programmed to 1x 64 time slots per frame mode, DD1 is tri-stated, independently of the IOM-2 interface push-pull or open-drain mode.

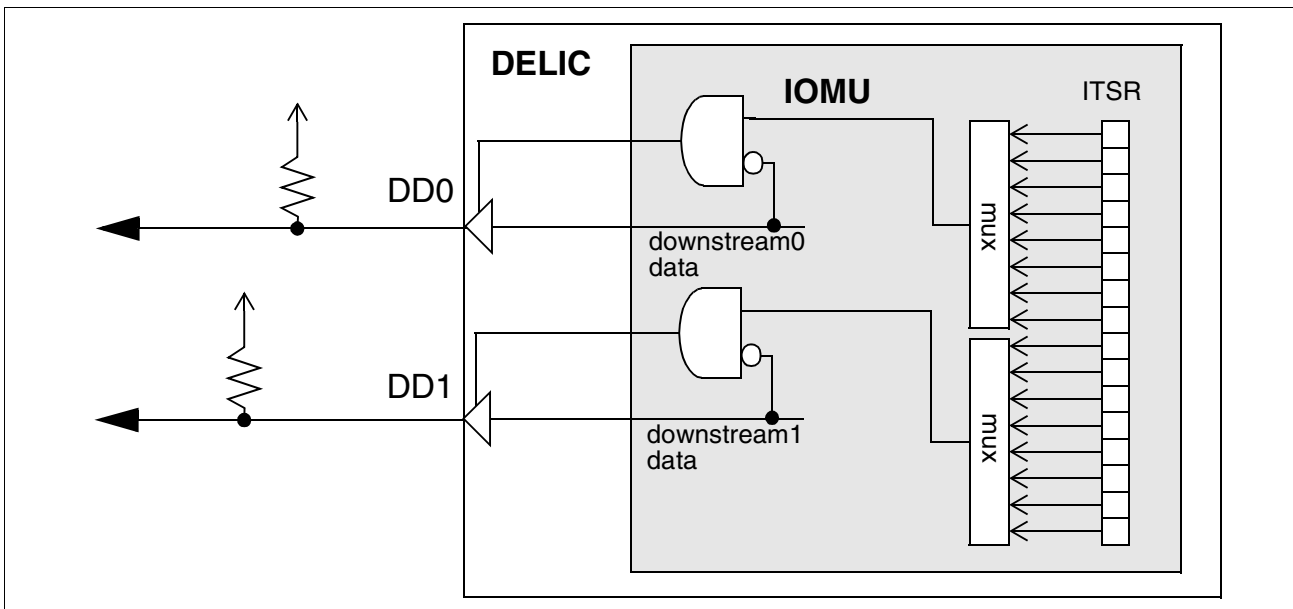

Figure 37 IOM-2 Interface Open-Drain Mode

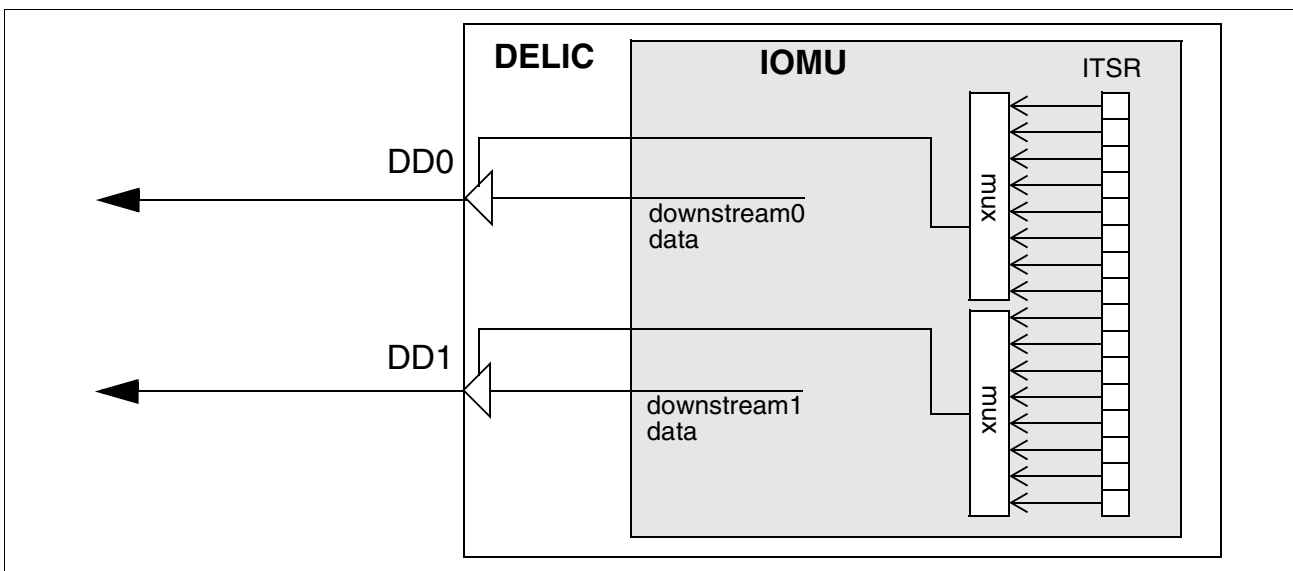

Figure 38 IOM-2 Interface Push-Pull Mode

4.3.2.9 Support of DRDY Signal from QUAT-S

The DRDY input is used when connecting an Infineon QUAT-S transceiver to the DELIC via the IOM-2 interface. It is driven by the QUAT-S to inform the DELIC when a D-channel is occupied by another S-interface device.

The IOMU supports the synchronous DRDY mode, i.e. the QUAT-S is operated in LT-T mode. In this mode, the DRDY signal is valid only during the D-channels.

DRDY = '0' means STOP (ABORT HDLC message), and DRDY = '1' means GO.

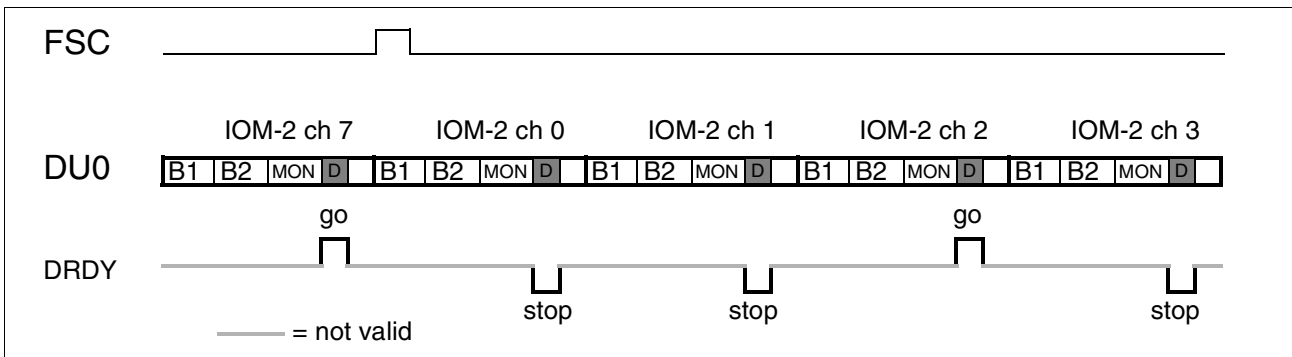

Figure 39 DRDY Signal Behavior

IOMU DRDY support features:

- Sampling DRDY only once every D-channel at the first bit.
- Sampling with the first DCL falling edge (in single data-rate DCL mode) or with the second falling DCL edge (in double data-rate DCL mode), refer to [Figure 40](#).
- DRDY support via IOM-2 port 0 only (with a constant delay of one 8 kHz frame)
- The status of the DRDY line can be read from register IDRDRYR

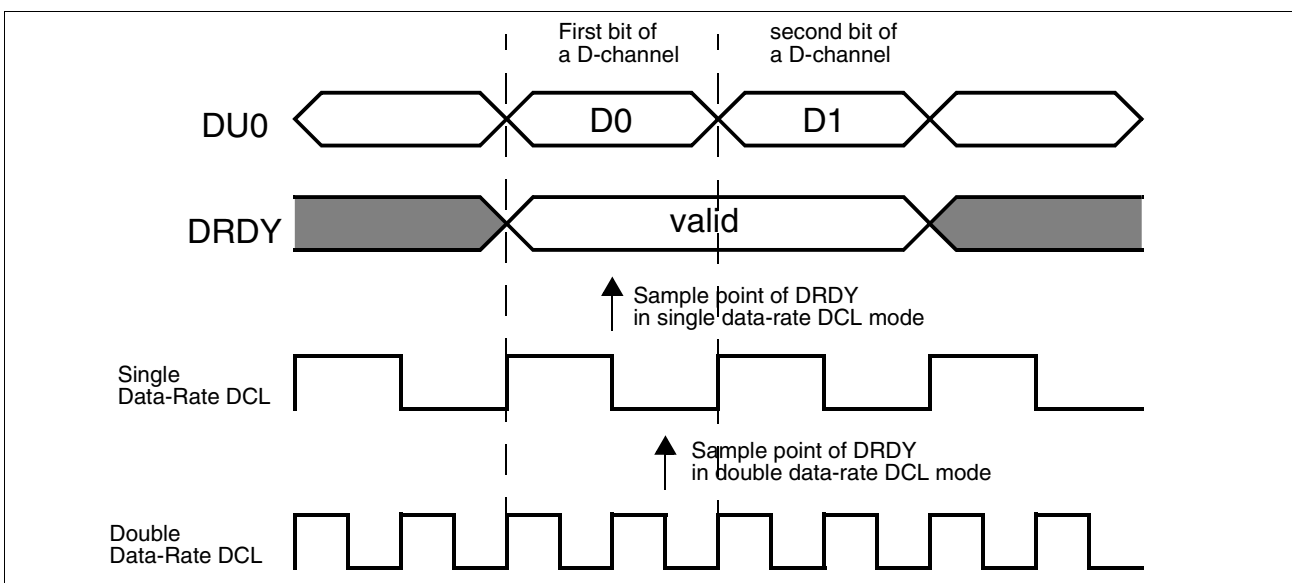

Figure 40 DRDY Sampling Timing

Note: If DRDY is not used, DRDY has to be set to 'high'.

4.4 PCM Unit

PCM Interface Features

The PCMU enables the DSP to control the 4 PCM ports. The DSP accesses the incoming PCM time slots, and prepares the outgoing PCM time slots. In general, the PCMU enables the DSP to switch time slots from PCMU to PCMU, IOMU and TRANSIU.

The basic structure and programming model of the PCMU is similar to the IOMU. However, the PCMU provides the double capacity of the IOMU. Thus it may handle up to 4 PCM ports and an overall of 128 time slots per frame in the receive direction and 128 time slots per frame in the transmit direction.

The following PCMU data rate modes are available:

- Four streams of 2.048 Mbit/s each (single and double clock)
- Two streams of 4.096 Mbit/s each (single and double clock)
- One stream of 8.192 Mbit/s (single and double clock)
- One stream of 16.384 Mbit/s (single clock). It is programmable, whether the first or the second 128 time slots of the 8 kHz frame are handled in the PCMU.

Note: Other data rates, e.g. 3 x 8.192 Mbit/s are possible by a firmware change. This is realized by assigning DSP data memory to the PCMU.

Tri-state control is performed via pins \overline{TSCn} , programmable per time slot and port.

4.4.1 PCMU Functional and Operational Description

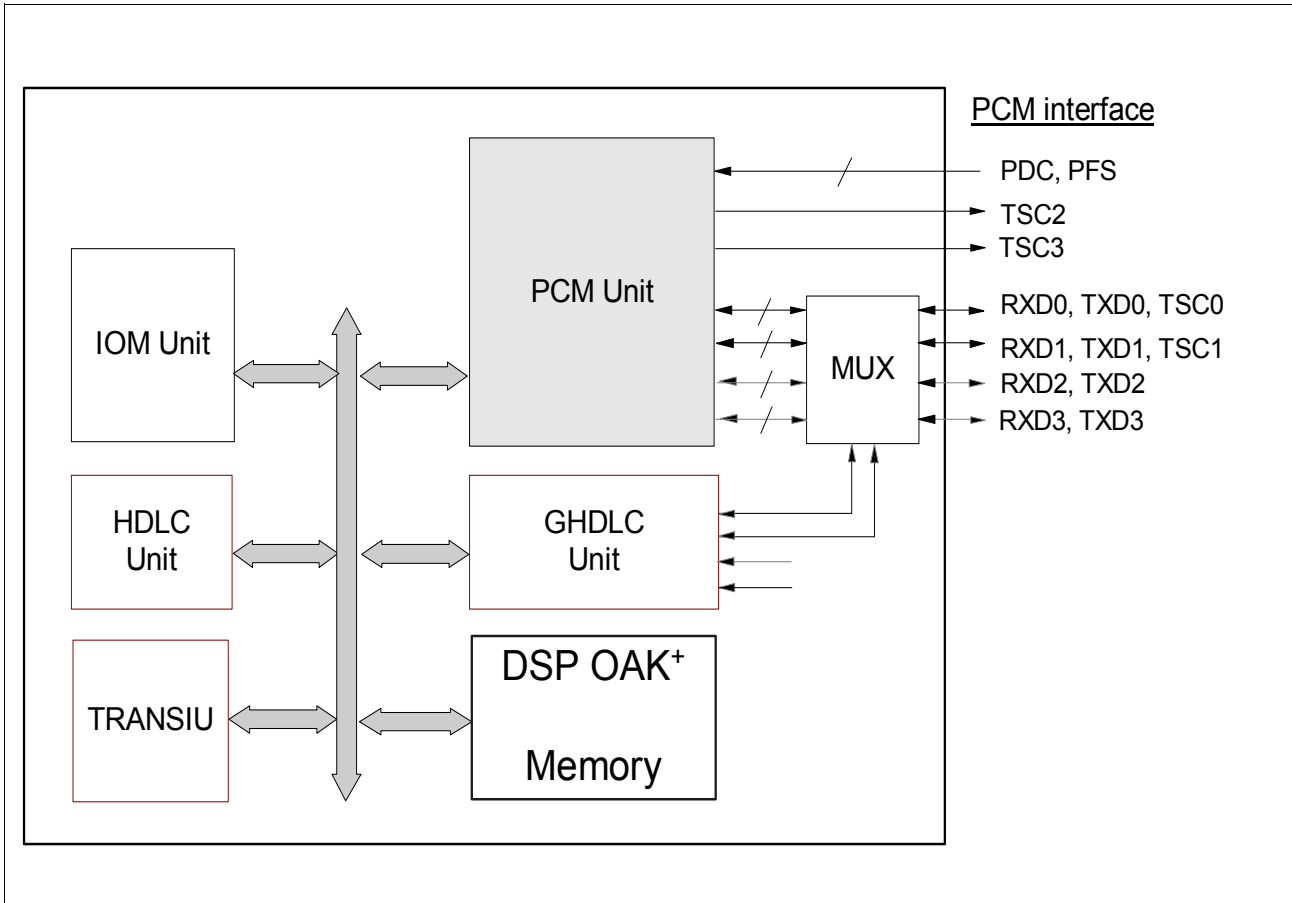

Figure 41 PCMU Integration in DELIC

The PCM-unit signals share port pins with the GHDLC-unit. A multiplexer controlled by register MUXCTRL allows to define the required functionality.

4.4.1.1 Frame-Wise Buffer Swapping

The main task of the PCMU is the serial-to-parallel conversion of incoming data to a parallel data format (and vice versa) which is directly read by the DSP. This access is required for the DSP to perform switching.

The data conversion in the PCMU is done by frame-wise swapping based on a circular buffer structure (see also [Figure 35](#)). During each 8 kHz frame one buffer is assigned to the PCMU (I-buffer) and the other one to the DSP (D-buffer). At the end of every frame the buffers are swapped.

4.4.1.2 DSP Inaccessible Buffer (I-buffer)

The logical partitioning of each frame buffer into input and output blocks is determined according to the requested data rate as shown in the table below.

Table 33 I-Buffer Logical Memory Mapping of Input Buffers

Data Rate	Input Blocks			
	in0	in1	in2	in3
related port	RXD0	RXD1	RXD2	RXD3
4 x 2.048 Mbit/s	00 _H - 1F _H	20 _H - 3F _H	40 _H - 5F _H	60 _H - 7F _H
2 x 4.096 Mbit/s	00 _H - 3F _H	-	40 _H - 7F _H	-
1 x 8.192 Mbit/s	00 _H - 7F _H	-	-	-
1 x 16.384 Mbit/s	00 _H - 7F _H	-	-	-

Table 34 I-Buffer Logical Memory Mapping of Output Buffers

Data Rate	Output Buffer Blocks			
	out0	out1	out2	out3
related port	TXD0	TXD1	TXD2	TXD3
4 x 2.048 Mbit/s	80 _H - 9F _H	A0 _H - BF _H	C0 _H - DF _H	E0 _H - FF _H
2 x 4.096 Mbit/s	80 _H - BF _H	-	C0 _H - FF _H	-
1 x 8.192 Mbit/s	80 _H - FF _H	-	-	-
1 x 16.384 Mbit/s	80 _H - FF _H	-	-	-

Note: In 1 x 16.384 Mbit/s only the first half of the frame is saved in the buffer

4.4.1.3 DSP Accessible Buffer (D-Buffer)

The D-buffer is mapped to a fixed DSP address space. Every DSP access to the D-buffer space is directed automatically to the appropriate sub-buffer. E.g. time slot 32 can be accessed at address 0xA020 in receive and 0xA0A0 in transmit direction.

Table 35 DSP Access to D-Buffer Input Blocks

Data Rate	Input Buffer Blocks			
	in0	in1	in2	in3
related port	RXD0	RXD1	RXD2	RXD3
4 x 2.048 Mbit/s	A000 _H - A01F _H	A020 _H - A03F _H	A040 _H - A05F _H	A060 _H - A07F _H
2 x 4.096 Mbit/s	A000 _H - A03F _H	-	A040 _H - A07F _H	-
1 x 8.192 Mbit/s	A000 _H - A07F _H	-	-	-
1 x 16.384 Mbit/s	A000 _H - A07F _H	-	-	-

Table 36 DSP Access to D-Buffer Output Blocks

Data Rate	Output Buffer Blocks			
	out0	out1	out2	out3
related port	TXD0	TXD1	TXD2	TXD3
4 x 2.048 Mbit/s	A080 _H - A09F _H	A0A0 _H - A0BF _H	A0C0 _H - A0DF _H	A0E0 _H - A0FF _H
2 x 4.096 Mbit/s	A080 _H - A0BF _H	-	A0C0 _H - A0FF _H	-
1 x 8.192 Mbit/s	A080 _H - A0FF _H	-	-	-
1 x 16.384 Mbit/s	A080 _H - A0FF _H	-	-	-

Note: In 1 x 16.384 Mbit/s only the first half of the frame is saved in the buffer.

4.4.1.4 PCMU Interface Data Rate Modes

The PCMU may support different serial data rates:

- up to 4 ports with 2048 Mbit/s (32 time slots per frame)
- up to 2 ports with 4.096 Mbit/s (64 time slots per frame)
- 1 port with 8.196 Mbit/s (128 time slots per frame)
- 1 port with 16.384 Mbit/s (only 128 time slots of the frame are supported)

The PCMU circular buffer may handle up to 128 time slots per frame. Thus, when e.g. configured in 4.096 Mbit/s mode, only PCM port 0 and 2 are used. In this case PCM port 1 and 3 remain in IDLE mode, i.e. the TXD1, TXD3 output pins are tri-stated.

For the data rate modes up to 8.192 MBit/s, single rate Data Clock (PDC) or double rate Data Clock may be selected. For 16.384 MHz mode only single clock is supported.

Single Data Rate PDC Mode

- Serial transmission via TXDn with every DCL rising edge
- Sampling of the incoming serial data (RXDn) with every PDC falling edge
- Sampling PFS with every PDC falling edge. Sampling of PFS = 1 after sampling of PFS = 0 is considered to be the start of a frame.

Double Data Rate PDC Mode

- Two PDC cycles per bit (the bits are aligned to the frame start)
- Serial transmission via TXDn with every second PDC rising edge.
- Sampling of incoming serial data (RXDn) with the second PDC falling edge of each bit.
- Sampling of PFS every PDC falling edge. Sampling of PFS = 1 after sampling of PFS = 0, is considered to be the start of a new frame.

Figure 36 shows the PCM interface timing with single and double rate PDC.

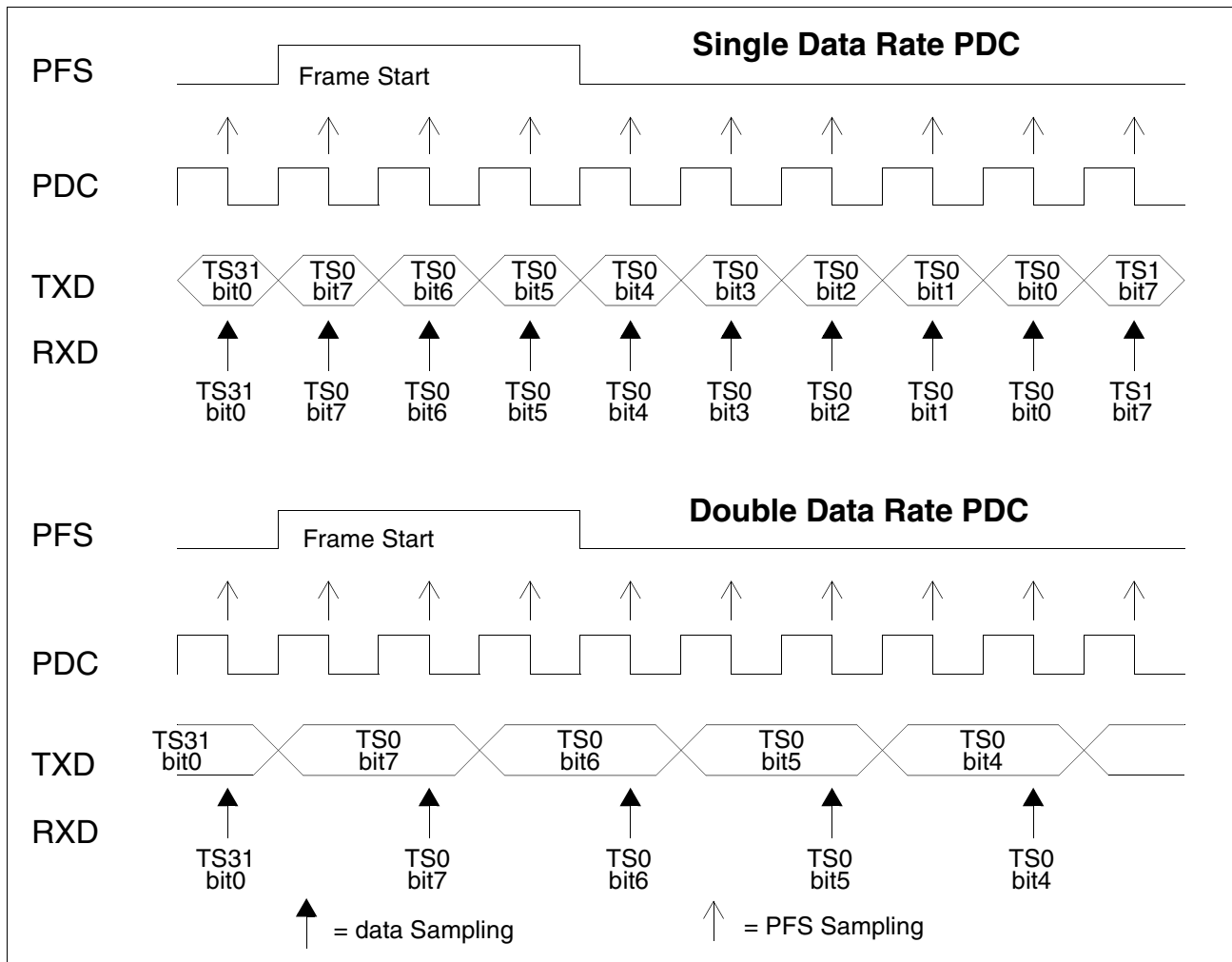

Figure 42 IOM-2 Interface Timing in Single/Double Clock Mode

4.4.1.5 PCMU Serial Data Processing

The incoming serial data is converted into parallel bytes, and stored in the I-buffer input blocks. The sequence for every time slot received is from MSB (bit 7) to LSB (bit 0). Transmission is performed from MSB (bit 7) to LSB (bit 0).

4.4.1.6 PCMU Parallel Data Processing

The data read from the PCMU frame buffers by the DSP always reside in the low byte of the 16-bit word. The high byte of the read word is driven by the 8-bit PCMU Data Prefix Register (P DPR). The data prefix is used to accelerate the A- μ -law to linear conversions (refer to [Chapter 4.5](#)).

Any octet written by the DSP to any location in the PCMU frame buffers should reside in the low byte (8 LSB). The high byte of the written word is “don’t care”.

4.4.1.7 PCMU Tri-state Control Logic

There are eight 16-bit tri-state control registers in the PCMU. Each bit determines whether its associated time slot is valid or invalid.

- '0' = the controlled time slot is invalid
- '1' = the controlled time slot is valid

The tri-state bits control the data transmit pins TXD0 - TXD3.

A special set/reset write method is used for updating the tri-state control registers. Every tri-state control register is mapped to 2 addresses: the first is used for set operation, the second for reset operation. Both addresses may be used for read operation.

- Set operation: This operation is executed during DSP write access to the set address of one of the TSC registers. The bits in the TSC register are set to '1' according to the bits in the written word. The other bits maintain their value.
- Reset operation: This operation is executed during DSP write access to the reset address of one of the TSC registers. The bits in the TSC register are reset to '0' according to the bits in the written word. The other bits maintain their value.

The Tri-state Control Registers (PTS0-7) can be accessed by the DSP. Every bit of them controls the TSC signal of one of the 4 PCM ports, for one time slot. The time slot and the port controlled by every bit depend on the data rate mode. In 1 x 256 TS/frame, it depends also on the selected half of the frame. Each TSC signals controls directly its respective TxD port, and is also driven outward via the corresponding TSCn output pin.

For the 4 x 32 time slot per frame mode, the next table depicts which port is controlled by each TSC register, and during which time slot. Bit 0 of each TSC register controls the first time slot of the listed time slot range, bit 1 controls the second one etc.

Table 37 PCM TSC in 4 x 32 TS Mode (4 x 2 MBit/s)

Time Slots	TSC0	TSC1	TSC2	TSC3
0..15	PTSC0	PTSC2	PTSC4	PTSC6
16..31	PTSC1	PTSC3	PTSC5	PTSC7

In 2 x 64 time slot per frame mode, only PCM ports 0 and 2 are used. TSC1 and TSC3 are permanently '0' (all time slots are invalid).

Table 38 PCM TSC in 2 x 64 TS Mode (2 x 4MBit/s)

Time Slots	TSC0	TSC1	TSC2	TSC3
0..15	PTSC0	inactive	PTSC4	inactive
16..31	PTSC1	inactive	PTSC5	inactive
32..47	PTSC2	inactive	PTSC6	inactive
48..63	PTSC3	inactive	PTSC7	inactive

Functional Description

In 1 x 128 time slot per frame mode, only PCM port 0 is used. TSC1, TSC2 and TSC3 are permanently '0' (all time slots are invalid). In 1 x 256 time slot per frame mode, only one half of the frame is used. All TSC pins are permanently '0' during the other half of the frame.

Table 39 PCM TSC in 1 x 128 TS (1 x 8 MBit/s) and 1 x 256 TS (1 x 16 MBit/s) (1st Half) Mode

Time Slots	TSC0	TSC1	TSC2	TSC3
0..15	PTSC0	inactive	inactive	inactive
16..31	PTSC1	inactive	inactive	inactive
32..47	PTSC2	inactive	inactive	inactive
48..63	PTSC3	inactive	inactive	inactive
64..79	PTSC4	inactive	inactive	inactive
80..95	PTSC5	inactive	inactive	inactive
96..111	PTSC6	inactive	inactive	inactive
112..127	PTSC7	inactive	inactive	inactive

Note: The same structure applies to the 256 TS per frame (first frame half) mode, except that all time slots (0..127) are transmitted in the first half of the 8 kHz frame.

Table 40 PCM TSC in 1 x 256 TS (1 x 16 MBit/s) (2nd Half) Mode

Time Slots	TSC0	TSC1	TSC2	TSC3
0..127	inactive	inactive	inactive	inactive
128..143	PTSC0	inactive	inactive	inactive
144..159	PTSC1	inactive	inactive	inactive
160..175	PTSC2	inactive	inactive	inactive
176..191	PTSC3	inactive	inactive	inactive
192..207	PTSC4	inactive	inactive	inactive
208..223	PTSC5	inactive	inactive	inactive
224..239	PTSC6	inactive	inactive	inactive
240..255	PTSC7	inactive	inactive	inactive

Note: Concerning the behavior of PCM output driver also see [“PCM Output Driver Anomaly” on Page 286](#)

4.5 A- μ -law Conversion Unit

The A- μ -law Unit performs a bi-directional conversion between a linear representation of voice data and its companded representation (according to **A-law** or **μ -law**). The conversion is applicable on all B-channels via IOM-2, IOM-2000 or PCM.

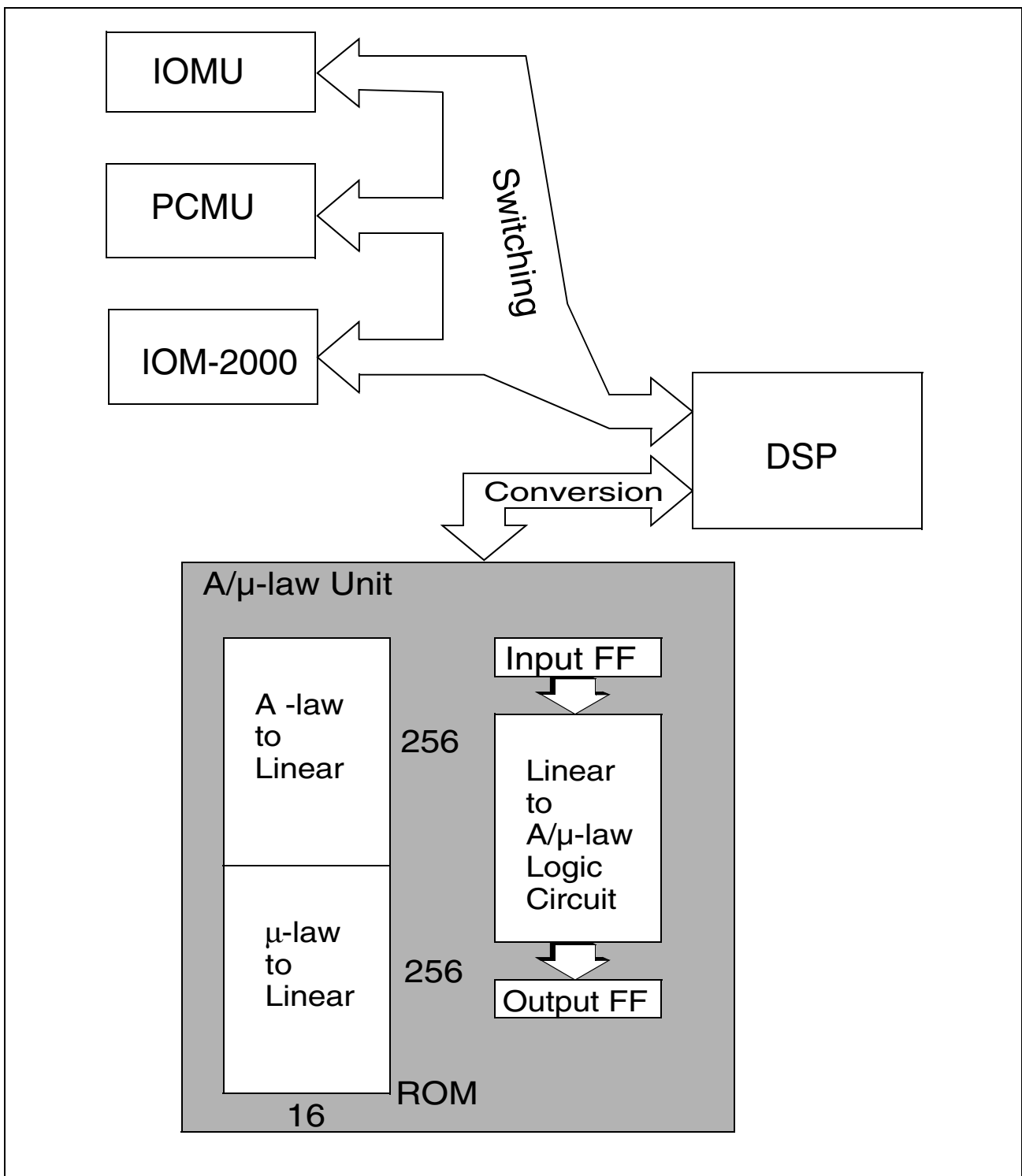

Figure 43 A- μ -law Unit Integration

A- μ -law to Linear Conversion

The conversion is done via a 512 x 16 ROM table. The low 256 bytes translate the A-law value into linear, while the high 256 words translate the μ -law to linear.

The DSP issues a read cycle, in which the 8 MSBs of the 16-bit address represent the ROM table address, and the 8 LSBs are the actual value which is to be converted. The converted linear value is the contents read from the ROM. Note that no wait states are required for this direction of conversion.

A-law values in the ROM are stored in the 13 MSBs. The 3 LSBs are always '0'. The μ -law values in the ROM are stored in the 14 MSBs. The 2 LSBs are always '0'.

Linear to A- μ -law Conversion

The conversion is done by dedicated hardware. The DSP programs the control register to perform either A-law or μ -law conversion. The linear value is written into the Input register (AMIR), and the A-law or μ -law value is read from the Output register (AMOR). Note that this is only possible one cycle later.

4.6 HDLC Unit

4.6.1 HDLC Overview

High-level data link control (HDLC) is a most common protocol in the data link layer, layer 2 of the OSI model. Signalling protocols LABD and LAPB are based on HDLC and its framing structure: Opening Flag, Address Field, Control Field, Data Field, CRC, Closing Flag, Interframe Timefill.

HDLC uses a zero insertion/deletion process (bit-stuffing) to ensure that a data bit pattern matching the delimiter flag (01111110 = 7EH) does not occur in a field between the starting and the closing flag. The HDLC frame is synchronous. An address field is needed to carry the frame's destination address because the frame can be sent to different systems. An address field can be 8, or 16 bits long, depending on the data link layer protocol. LAPB uses an 8-bit address, LAPD 16-bit address. The length of the data in the data field depends on the frame protocol. Error control is implemented by appending a cyclic redundancy check (CRC) to the frame, which is 16 bits long.

The multichannel HDLC controller within the DELIC consists of two parts: a hardware block (HDLC Unit) and a dedicated on-chip processor (OAK DSP). The processor handles the HDLCU by writing/reading signalling data and reacts on slow events by software.

The following table shows the main HDLC features and the responsible unit for its handling:

HDLC Features	HDLC Unit	Processor
Flag detection and generation	X	
Zero insertion/deletion (bit stuffing)	X	
16-bit CRC-CCITT generation and checking	X	
Time slot assignment (2- or 16-bit)		X
Programmable flags between successive frames	X	X
Flexible address handling		X
Flexible buffers management (per frame)		X
Separate interrupts for frames and buffers (Rx and Tx)		X
Flag/abort/idle generation and detection	X	X
Detection of non-octet aligned frames	X	
Automatic retransmission in case of collision		X

Note: The multichannel HDLC Unit is not connected to any DELIC pin.

Functional Description

The HDLC automatically recognizes HDLC frames with the following interframe time fill combinations:

- n consecutive flags (n = 1, 2, 3,.. ; n = 1 is called shared flag, if the closing flag of one frame is the opening flag of the next frame. n > 1 is also called unshared flag mode.)
- m "ones" between the closing flag and the opening flag (even when m = 1 to 5)
- corrupted flag between the closing flag and the opening flag

The HDLCU may process up to 32 full-duplex HDLC channels in parallel. As it is controlled by the DSP, it is very flexible. The HDLCU includes 32 Receive Input Buffers, 32 Receive Output Buffers, 32 Transmit Input Buffers and 32 Transmit Output Buffers, some HDLC protocol processing logic and a command RAM.

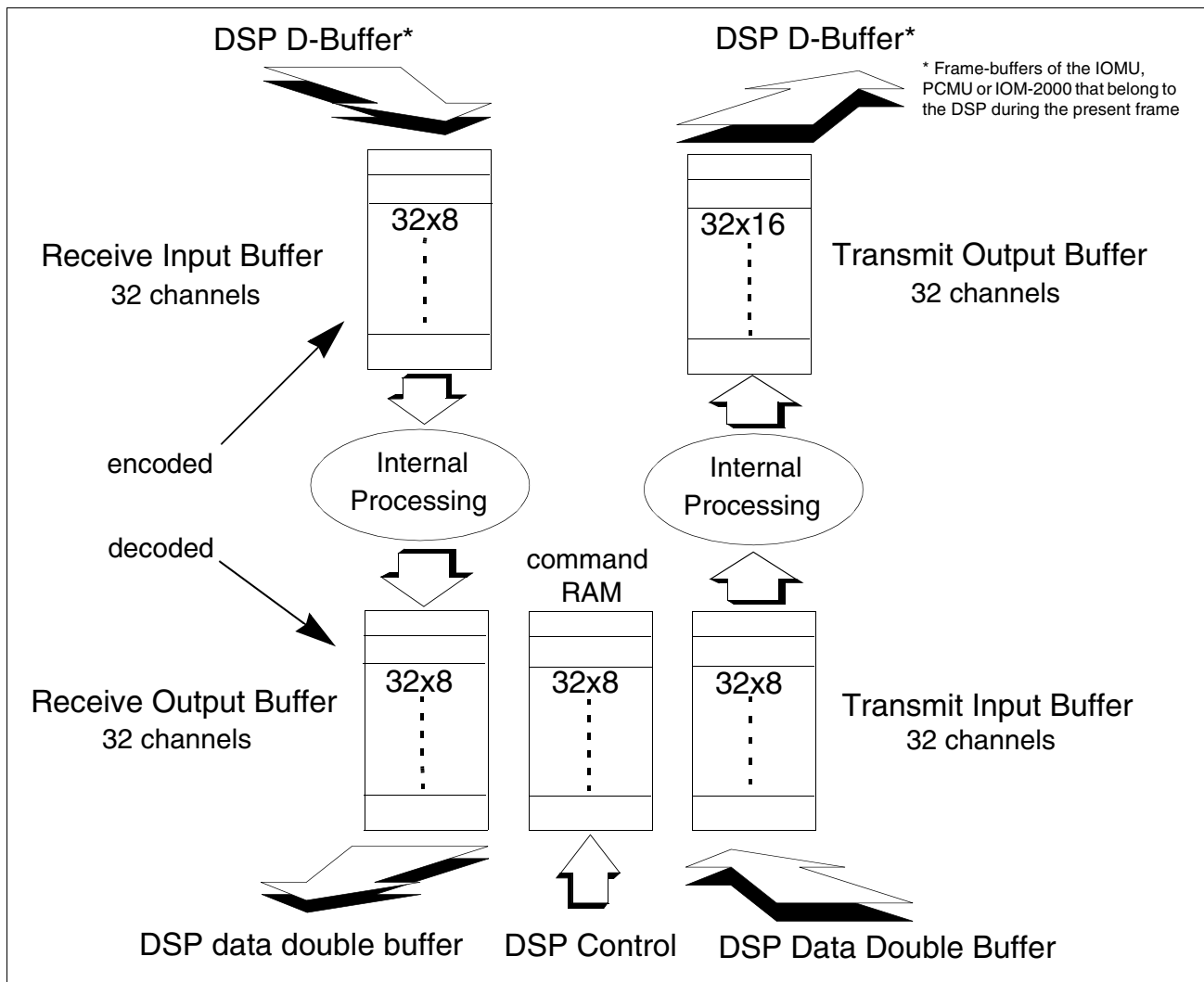

Figure 44 HDLCU General Block Diagram

Figure 44 shows the HDLCU structure. Each buffer, except the Transmit Output Buffer, is 1 Byte small, hence one byte is assigned to each HDLC channel per direction. The Transmit Output Buffer is 2 Bytes as it also contains a 7-bit status vector assigned to the channel.

Functional Description

The DSP assigns each time slot used for transmitting an HDLC message to a different address in the Receive/Transmit Input Buffers. The HDLCU decodes/encodes the time slots into the corresponding addresses in the Receive/Transmit Output Buffers.

During every frame, two HDLCU activities are performed:

1. DSP access to the HDLCU
2. HDLCU encoding/decoding

At the beginning of a frame the DSP checks if the HDLCU is busy (HHOLD = '0').

Note: The DSP may only access the buffers and command RAM when DSPCTRL = '1'.

In the **receive direction** the DSP places HDLC message time slots to be processed from the D-buffers into the Receive Input Buffer. Processed message time slot octets may be read by the DSP from the Receive Output Buffer.

In the **transmit direction** the DSP places HDLC message time slots to be processed in the Transmit Input Buffer. Processed time slots may be read from the Transmit Output Buffer and placed into the D-Buffer of the IOMU, PCMU or TRANSIU from which they will be transmitted during the next frame.

4.6.2 HDLCU Operation

4.6.2.1 Initialization of the HDLCU

The DSP first resets the receive and transmit mechanisms of all HDLC channels.

1. The DSP requests the External Controller for HDLCU setup.
2. The DSP sets the bit DSPCTRL to '1'.
3. The DSP resets the receive mechanism and transmit mechanism of a channel by setting the RECRES flag of its command vector to '1' and inserting an abort command. The DSP also writes the setup of the HDLCU.
4. The DSP sets DSPCTRL to '0'.
5. When the HDLCU finishes processing (HHOLD = '1'), the HDLCU is initialized and is ready for use.

4.6.2.2 Transmitting a Message

The DSP must place a Start transmission command at the appropriate address in the command RAM. If CRC encoding is required, the DSP must set bit 1 to '1' in the command vector. After the first flag has been transmitted, the HDLC starts to transmit the message. In shared flag mode the HDLCU starts transmitting the message in the frame adjacent to the reception of the Start transmission command.

Note: Messages with zero byte data content are not supported.

4.6.2.3 Ending a Transmission

When placing the last octet of the message into the Transmit Input Buffer, the DSP places an End transmission command in place of the Start transmission command without changing the CRC bit.

If CRC encoding is required, the CRC vector will be transmitted bit by bit after the octet of the message, and then a flag will be transmitted. If CRC encoding is not required, a flag will be transmitted directly after the last octet of the message.

4.6.2.4 Aborting a Transmission

In order to abort transmission of a message over a dedicated channel, the DSP places an abort command in the appropriate address in the command RAM. The message being transmitted over the channel is aborted and 'ones' are transmitted over the channel instead (even in shared flag mode).

4.6.2.5 DSP Access to the HDLCU Buffers

Reading a channel from the Receive Output Buffer and writing to a channel in the Transmit Input Buffer is done according to the channel status vector and according to the Empty and Full procedures as shown below:

Empty procedure

- If the **EMPTY** flag of a channel is set by the HDLCU to '1', then move a new time slot to be transmitted from the pipe to the Transmit Input Buffer.
- If the pipe is empty change the pipe page and ask for the next 8 bytes of data from the external controller by means of DMA or transfer ready indication.

Note: The B-channel buffer may be emptied within a single frame, while it takes at least 4 frames to empty a D-channel buffer.

Full procedure

- If the **FULL** flag of a channel is set by the HDLCU to '1' then the DSP moves the time slot from the Receive Output Buffer into the double buffer.
- If the pipe is full change the pipe page and transfer the next 8 bytes of data to the External Controller by means of DMA or transfer ready indication.

Note: The B-channel buffer may be filled within a single frame, while a D-channel buffer will take at least 4 frames to fill.

4.6.3 Functionality

The multichannel HDLC controller can be assigned to any timeslot on any time-division multiplexing (TDM) port: IOM-2, PCM and TRANSIU.

Functional Description

In receive direction, the processor fetches the D-channel (16 kbit/s signalling) or the B-channel (64 kbit/s) from the assigned timeslot and writes it into the corresponding channel register of the HDLC Unit. After the HDLC Unit encoded the data (e.g. performed bit stuffing), the processor reads ready data and stores it in the receive buffer in on-chip memory. The data flow is shown in the following figure.

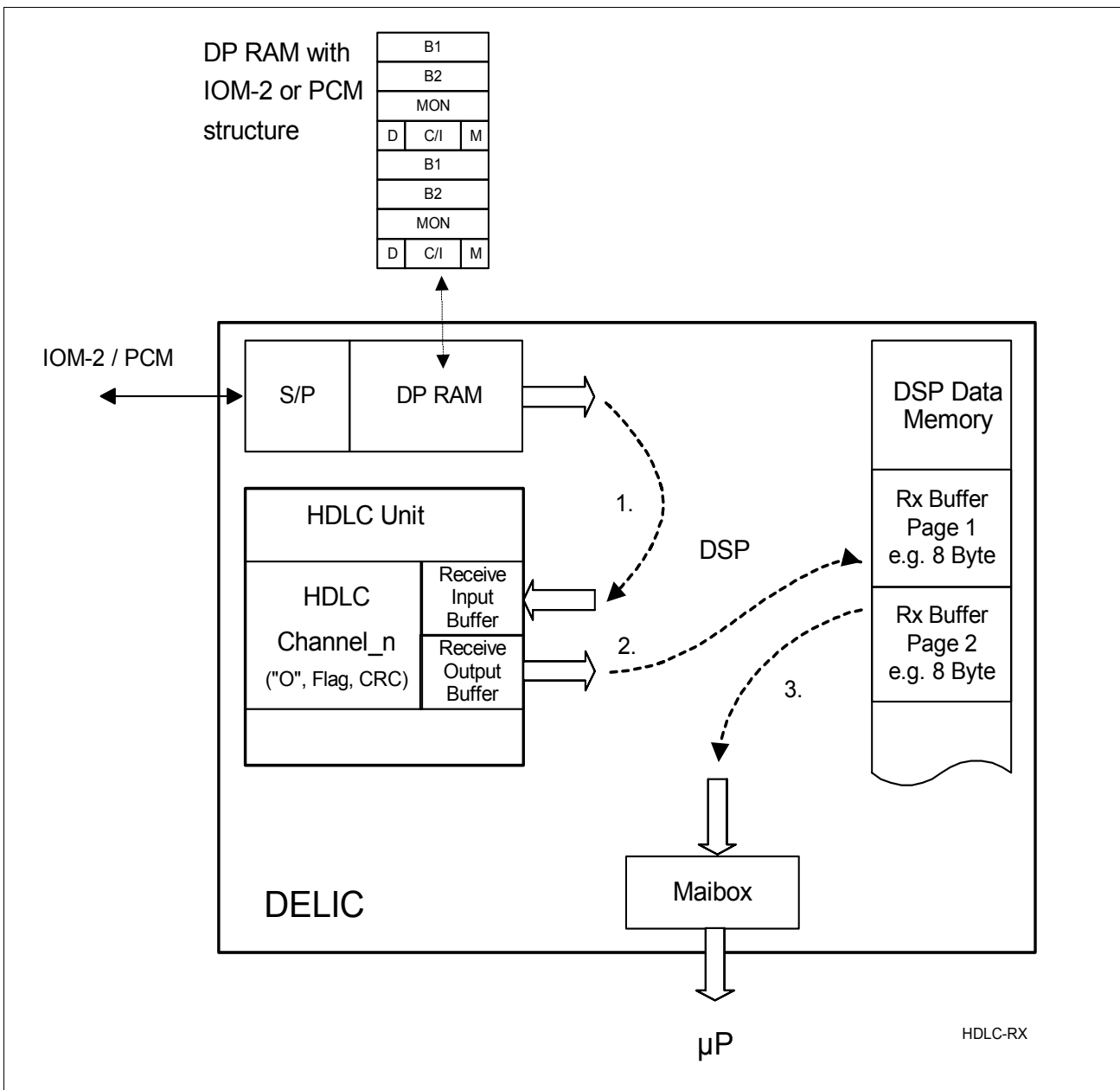

Figure 45 HDLC Data Flow in Receive Direction

The Receive Input and Receive Output Buffers within the HDLCU are 1 Byte per HDLC channel. The main Rx Buffer in DSP RAM is 2 x 8-Byte large per HDLC channel (in the DELIC-LC version).

Functional Description

The processor handles the HDLCU (tasks 1) during every IOM frame, i.e. every 125 μ s. If a 16-kbit/s channel is handled, the task 2 is performed about every 4th to 5th frame (4 x 2-bit writing to the HDLCU minus "0-detection" => 8-bit output).

At the beginning of a frame, the DSP checks if the HDLCU is busy (HHOLD = '0').

The DSP may only access the buffers and command RAM when DSPCTRL = '1'.

In **transmit direction**, the DSP writes data 8-bit wise into the Transmit Input Buffers, reads the processed data from the Transmit Output Buffers and places the coded data into the assigned destination time slot like in the following example:

- 2-bit wise writing into the D-channel of an IOM-2 interface of the IOM Unit, or into the TRANSIU in case of TRANSIU interface,
- 8-bit wise writing into a signalling channel of the PCM highway by writing into the PCM Unit.

In general, the HDLC controller can handle all 32 HDLC channels at different data rates using any TDM channel: e.g.

- 16 kbit/s for D-channel signalling
- 64 kbit/s for B-channel signalling
- 8 kbit/s for proprietary signalling (only PB version)
- 256 kbit/s for data transfer in transparent mode.

4.7 GHDLC Unit

4.7.1 GHDLC Overview

Messages are transceived serially, bit by bit over the line and undergo encoding/decoding according to the HDLC protocol. A received message is collected bit by bit from the line and stored as octets in the Receive buffer and read by the DSP. A transmitted message which is placed by the DSP as octets in the Transmit buffer, is transmitted bit by bit over the line.

The GHDLC (General HDLC) controller works similar to HDLCU (refer to [“HDLC Overview” on Page 113](#)). Main features/differences:

- it has its own physical interface with the following signal lines: LRxD, LTxD, LTSC, LCxD, LCLK,
- it works at a speed of up to 8.192 Mbit/s
- it supports also multi master bus
- it may work independently from the internal clocking (FSC, PDC,..) using an external clock
- the receive/transmit buffer in the GHDLC are 2 x 32 Bytes large, respectively

Like the HDLC Controller, the GHDLC Controller consists also of two parts: a hardware block (GHDLC Unit for fast events) and a processor (OAK DSP).

Data from the serial input line (LRxD) is processed and stored in the Receive Buffer which is to be read by the DSP. Transmit data is placed by the DSP in the Transmit Buffer, is processed by hardware and transmitted over the serial line (LTxD).

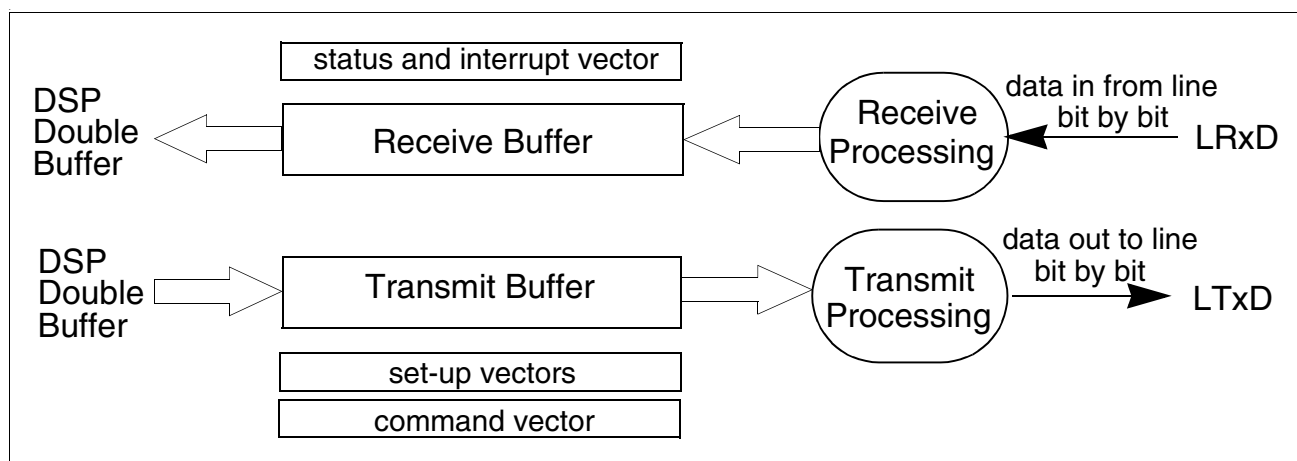

Figure 46 Data Processing in the GHDLC

4.7.2 GHDLC General Modes of Operation

Each GHDLC channel has three main modes of operation:

- **HDLC Mode:** In this mode flag-recognition/insertion and zero deletion/addition are performed. CRC decoding/encoding may be performed.

Functional Description

- **Transparent Mode:** No HDLC framing exists. In the receive direction everything on the line is automatically passed to the buffer. Each time the buffer is filled an interrupt to the DSP is generated.
- **Asynchronous Mode:** This mode is used with request to send/ clear to send handshaking. In this mode data is transmitted over a channel at a very slow rate of up to 300 baud and controlled directly by the DSP.

RTS/CTS Hand-shaking

In point to point configuration the LCxD and LTxD are used for CTS and RTS handshaking. A transmission request is indicated by outputting a logical '0' on the request to send output (RTS). After having received the permission to transmit (CTS), the HDLC starts data transmission. If permission to transmit is withdrawn in the course of transmission, the frame is aborted and an idle is sent.

4.7.3 External Configuration and Handshaking in Bus Mode

The GHDLIC is connected to the following DELIC interface lines:

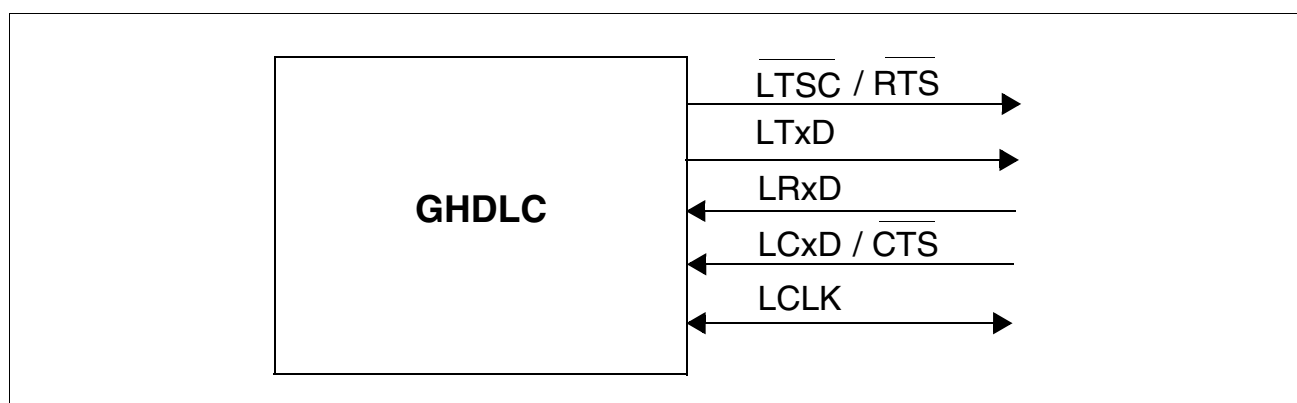

Figure 47 GHDLIC Interface Lines

Serial data is transceived over the LRxD/LTxD lines. The line clock can be driven by an external GHDLIC device or can be generated internally by the PCM clocking path. The selected internal clock is also driven outward via LCLK.

4.7.3.1 External Tri-State in Point-to-Multi-Point Mode

$\overline{\text{LTSC}}$ is the external tri-state control line. When $\overline{\text{LTSC}}$ is high LTxD is disabled and in high impedance state. When $\overline{\text{LTSC}}$ is low, LTxD may take on values 0 or 1 when in push pull mode, 0 or high impedance when in open drain mode.

4.7.3.2 Arbitration Between Several GHDLICs

Arbitration between several GHDLICs can be done in two ways:

- Polling
- Collision Detection

Functional Description

Polling means that the DSP is polled to see if it has anything to send by way of a frame which is actually a question. The GHDLC simply receives this frame and passes it on to the DSP like any other.

Note: This mode is not supported by the DELIC-LC.

When using Collision Detection many GHDLCs may start transmitting at the same time. Suppose that several GHDLCs start transmitting simultaneously, the first byte transmitted is always a flag which is common to every GHDLC. Afterwards each GHDLC transmits its address which is, of course, unique to each GHDLC. When a difference is discovered between the transmitted bit (LTxD) and the collision bit (LCxD), the transmission is aborted. The GHDLC will try to send the message again after it has detected the bus to be idle for a specified time, according to its **class**. Arbitration on a line is such that the GHDLC channel with the lowest address gets the highest priority. All the GHDLC channels are divided up into two groups: classes 8, 9 and classes 10, 11. Initially the DSP programs each channel to be either class 8 or 10. If during transmission a bit collision occurs the GHDLC will have to count 8 consecutive ones (in class 8) or 10 consecutive ones (in class 10) before it tries to retransmit. After a certain GHDLC channel succeeds in making a full transmission its class is increased by 1 to 9 or 11 so that if a bit collision occurs the GHDLC channel will have to count more ones before retransmitting. After the GHDLC channel has counted 9 or 11 consecutive ones its class is brought back down to its former level (see ITU-T 1.430 section 6.1.4).

Collision Detection in Point-to-Multi Point Configuration

The GHDLC can perform a bus access procedure and collision detection. As a result, any number of HDLC controllers can be assigned to one physical channel, where they perform statistical multiplexing. When a mismatch between a transmitted bit and the bit on CxD is detected, the GHDLC stops sending further data and an idle is transmitted. As soon as it detects the transmit bus to be idle again, the GHDLC automatically attempts to re-transmit its frame. The DSP programs the HDLC its class and the HDLC performs a priority mechanism to detect idle on the line.

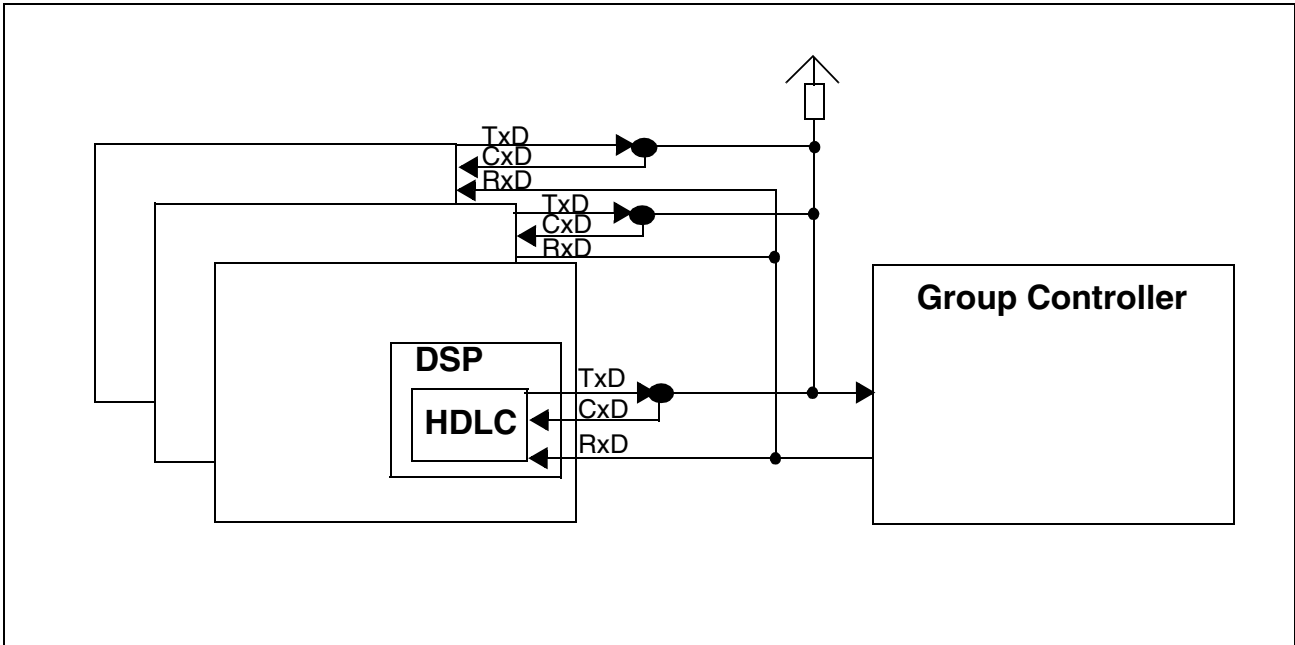

Figure 48 Point-to-Multi Point Bus Structure

If a TxD and CxD difference occur, the HDLC aborts its transmission, generates an interrupt for the DSP reporting the collision and disables the output of TxD (High Impedance or '1' programmable selecting). The HDLC automatically restarts transmission when the bus is detected to be idle again. The HDLC detects idle if CxD was 'high' for $(8 + 2 \cdot \text{Class} + D)$, where Class is a DSP programmable and is 0 for class 1 and 1 for class 2. D is 1 between a success transmission and idle detection on the bus.

4.7.4 GHDLC Memory Allocation

The memory in the GHDLC is build by a 128 x 8 bit RAM equally divided between the GHDLC and the DSP. The GHDLC has a receive buffer and a transmit buffer, divided into two blocks. One block is allocated to the GHDLC channel in the receive direction, the other block is read by the DSP. Similarly in the transmit buffer, one block is allocated to the GHDLC channel in the transmit direction, the other block is written to by the DSP as shown in [Figure 49](#). Note that the GHDLC has higher priority for the buffer access, whereas the DSP is able to read and write the RAM at a much higher frequency.

The DELIC contains 4 GDLC Controllers.

If only one GHDLC Controller is used, the visible buffer size is 32 bytes for each direction, for two channels 16 bytes per channel and for 4 channels 8 bytes per channel.

Memory is allocated to each receive and transmit buffer according to the number of used channels by the following table:

Functional Description

	Receive Buffer		Transmit Buffer	
	Block 0	Block 1	Block 0	Block 1
one channel	32 bytes	32 bytes	32 bytes	32 bytes
two channels	16 bytes	16 bytes	16 bytes	16 bytes
four channels	8 bytes	8 bytes	8 bytes	8 bytes

This leads to the following address configuration:

Table 41 GHDLCU Receive Buffer Configuration

No. of Channels	Direction	Channel Address			
		ch 0	ch1	ch 2	ch3
1 channel	Receive	0x2040			
	Transmit	0x2000			
2 channels	Receive	0x2040			0x2060
	Transmit	0x2000			0x2020
4 channels	Receive	0x2040	0x2060	0x2070	0x2050
	Transmit	0x2000	0x2020	0x2030	0x2010

In the receive direction, blocks are swapped in two cases:

- The receive buffer is full. The swap is issued immediately after the buffer has become full.
- An end of a frame indication was detected at the beginning of a frame. The frame is programmable to 62.5 μ s or 10 μ s (see [Chapter 6.2.6.15](#)). To avoid a loss of data in case of a buffer full indication followed by an end of frame indication, this condition becomes true only if additionally there was no **FULL** interrupt during the previous frame.

In the transmit direction blocks are swapped each time a start transmission command is issued in the command register.

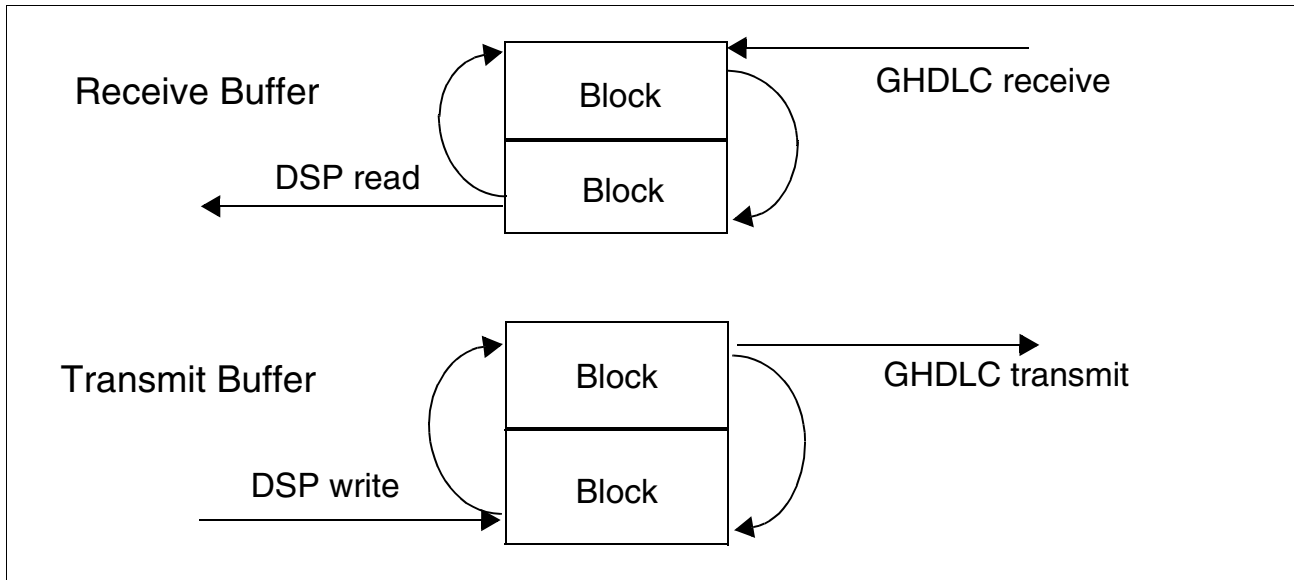

Figure 49 GHDLC Receive and Transmit Buffer Structure

The GHDLC unit and DSP always read and write to different areas in the RAM. Memory is equally allocated to each of the receive and transmit buffer blocks (32 bytes each).

The DSP always writes to the block addresses. The switching between blocks is done internally and does not concern the DSP.

4.7.5 GHDLC Interrupts

Full Interrupt: A full interrupt is generated if:

- The receive buffer is full. The interrupt is issued immediately after the buffer has become full.
- An end of a frame indication was detected at the beginning of a frame. The frame is programmable to 62.5 μs or 10 μs ([Chapter 6.2.6.15](#)). To avoid a loss of data in case of a buffer full indication followed by an end of frame indication, this condition becomes only true if additionally there was no **FULL** interrupt during the previous frame.

Empty Interrupt: An empty interrupt is generated every time a transmit buffer was emptied by the GHDLC.

Note: Messages with zero byte data content are not supported.

4.7.6 Operational Description

4.7.6.1 GHDLC Initialization

The initialization procedure include writing for each HDLC it's configuration to the registers set. The four HDLCs will be arranged according to the specified configuration.

4.7.7 GHDLC Protocol Features

The following GHDLC features related to HDLC protocol may be selected in HDLC mode:

- **Collision Detection:** May be active or inactive (relates only to the transmit direction)
- **Flags / Ones Interframe:** Flags or Ones are transmitted between each frame and are automatically recognized in receive direction. In transmit direction the GHDLCU can be programmed for either Interframe.
- **CRC Mode:** Two possible settings: 16-bit CRC / No CRC (relates to both the transmit and receive directions, and only when operating in the HDLC mode).
- **Push-Pull / Open drain:** In push pull mode a pin may be driven to '1' or '0'. When in open drain mode a pin may be driven to '0' or high impedance.

The GHDLCU is able to receive 'flags' as well as '1' as ITF. If flags are used as ITF the DELIC is able to detect ITF-flags with only one 'Zero' between the 'Ones' (shared '0').

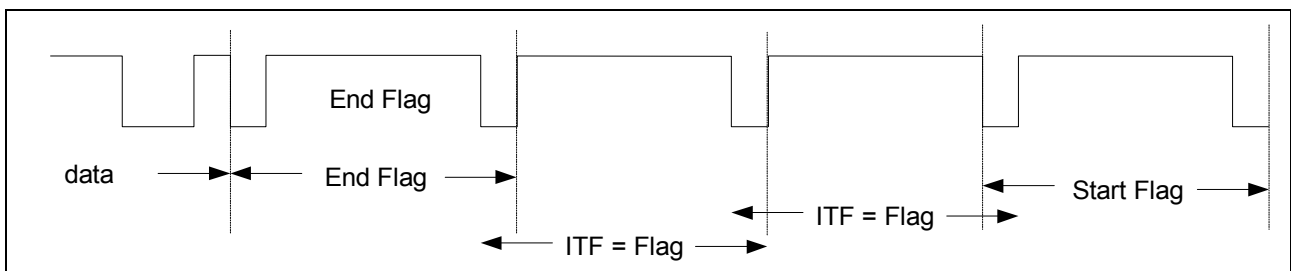

Figure 50 Interframe Time Fill with shared Zero

4.7.8 GHDLC possible Data Rates for the DELIC-LC/PB

The DELIC-LC has one GHDLC channel with a data rate of up to 2.048 Mbit/s.

Although the DELIC-PB features 4 GHDLC channels, not all channels are available for each application. If full duplex operation is assumed and if the receive data comes randomly, it's recommended to use not more than two channels with 2 Mbit/s or 1 channel with up to 8 Mbit/s.

The reason for this is that the data flow through the μ P-interface is limited by the μ P-access time, the maximum number of interrupts supported by the μ P and by the DMA-access time.

Assuming a system with 4 x 2 Mbit/s GHDLC ports this would mean a worst case interrupt repetition rate of 12.5 μ s (i.e. 4 x 32 bytes per direction have to be transmitted via a 32 byte mailbox). Usually the Operating System wouldn't allow such a high interrupt rate. However if the performance requirements can be reduced (e.g. not all channels are active at the same time or the HDLC packet size is small or the packet rate is low) then a system with 4 x 2 Mbit/s might be reasonable with the DELIC.

Data rates other than 2.048, 4.096 and 8.192 Mbit/s require an external clock. The DELIC may be configured to use an external clock for each GHDLC port.

4.7.9 GHDLC Using external DMA Controller

One of the four GHDLC channel of the DELIC-PB can be assigned to the DMA mailbox handled by an external DMA controller.

The detailed handling of DMA is described in [“DMA Mailbox \(DELIC-PB only\).” on Page 133.](#)

4.8 DSP Control Unit

4.8.1 General

The DSP Control Unit (DCU) controls the DSP access to DELIC's blocks. It performs the following tasks:

- DSP program and data address decoding
- Interrupt handling
- Data Bus and Program Bus arbitration
- DSP run time statistics
- Boot support
- Emulation support

4.8.2 DSP Address Decoding

The DCU decodes the DSP data address bus (DXAP) and the DSP program address bus (PPAP) for performing the following tasks:

- Generating the DSP memory mapped register controls, based on decoding of the 8 MSB lines of the data address bus
- Generating the GHDL, TRANSIU, HDLCU, IOMU and PCMU RAM controls
- Generating program and data RAM controls upon detection of their address
- Generating the read signal for the program ROM

4.8.3 Interrupt Handling

The following events are reported by the various telecom peripheral blocks to the DSP:

- GHDL
- DMA mailbox
- μ P mailbox
- IOM interface Frame synchronization (FSC) interrupt
- PCM interface Frame synchronization (PFS) interrupt

The GHDL, DMA Mailbox and Microprocessor Mailbox interrupt sources are assigned to the DSP interrupts (INT0, INT1 and INT2) as shown in [Figure 42](#). The FSC and PFS are reported as status bits (require DSP polling) in the Status Event Register (STEVE).

Table 42 Interrupt Map

Interrupt	Source
INT0	μ P DMA Mailbox
INT1	μ P General Mailbox
INT2	FSC & PFS
NMI	GHDL

Note: The NMI interrupt maybe enabled/disabled in the INTMASK register.

4.8.4 DSP Run Time Statistics

The DSP run time statistics is used for the DSP work load estimation. By using this HW, the maximum time spent by the DSP from the FSC until the tasks ends may be found.

The DSP statistics include an eight bit counter STATC which is counting up every 1 μ s.

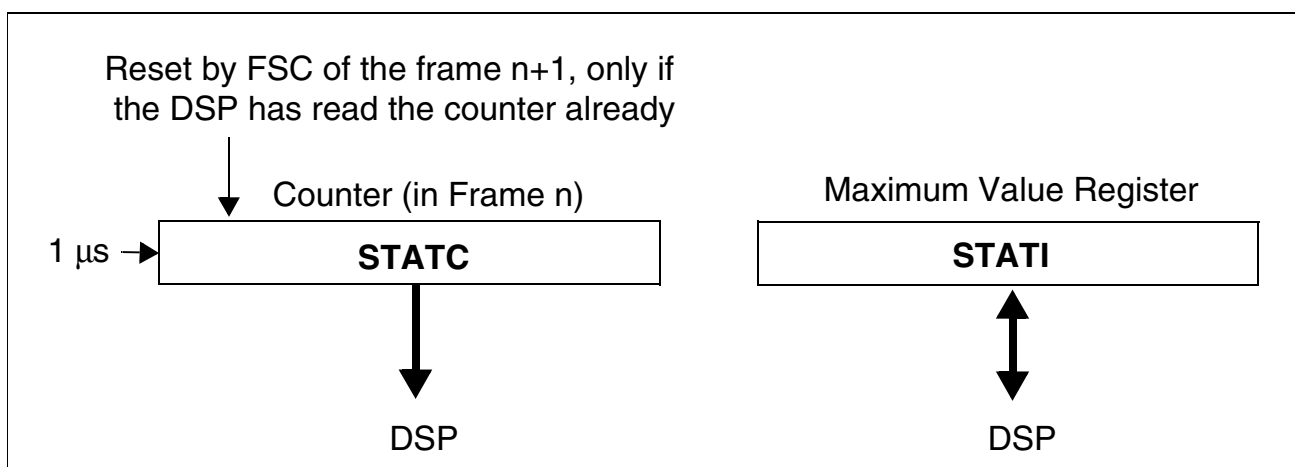

Figure 51 Statistics Registers

STATC is reset upon FSC rising edge. When the DSP finishes a task, it reads STATC. The time between two consecutive FSC is always 125 μ s, therefore, if the DSP is working properly, the counter value should always be less than 125 μ s.

If the DSP failed to read the counter value and a new FSC rising edge has arrived, the counter is not reset. Therefore, the DSP reads a value greater than 125. It means that the DSP failed to finish its tasks within the time frame of 125 μ s.

The STATI register is added for helping the user to perform the statistics. STATI is a general purpose 8-bit read/write register.

The user program should perform statistics in the following way:

- The STATC is reset upon detection of FSC rising edge.
- The DSP finishes its activities and reads the value of STATC and STATI. The DSP compares STATC to the previous maximum value saved in STATI.
- If the new value is larger, it is written to STATI.

The system programmer can get the counter value via μ P Mailbox and thus can change the DSP program.

4.8.5 Data Bus and Program Bus Arbitration

The internal data bus (GEXDBP) and program data bus (GIP) are tri-state buses. Since these buses must never float, the DCU keeps track of the bus activities. If during a dedicated cycle no driver is on the bus, the DCU puts a default value on the bus.

4.8.6 Boot Support

The μ P boot is the process which loads the external μ P program RAM via the μ P Mailbox into the on-chip DSP program RAM. The boot is controlled by a boot routine residing in the internal DSP program ROM. This routine is started upon DELIC reset according to the $\overline{\text{BOOT}}$ strap pin status.

The second boot option is the emulation boot, which loads the monitor (BI routine) to the program RAM. This routine enables the PC emulator to control the DSP.

At system start-up the program code for the DSP is transferred into the internal RAM from the external μ P. The contents for the program and data boot is delivered in a so called HEX file.

The code format of the HEX file is the following:

```
Code, :,16 bit address, 16 bit opcode
C:0000 4180
C:0001 0018
C:0004 4180
C:0005 00BA
C:0006 4180
C:0007 00BD
C:000E 4180
C:000F 00BE ...
```

The program boot starts with the "Start Loading Program RAM" command which is coming from the DELIC boot routine.

OCMD = 0x1F

This command must be polled from the μ P because the interrupt is still not activated.

The μ P confirms this with the "Start Boot" command.

MCMD = 0x55

Functional Description

The program code is now transferred in pieces of maximum 15 words by use of the "Write Program Memory Command".

MDT0 = 0xDESTINATION_ADDRESS

MDTn = 0xOPCODE_WORDn

MCMD = 0xAn[n=1..15 number of code words to write to address++]

Before writing this command, the μ P must check that the mailbox is free. This is done by reading the MBUSY bit (bit 7 of address 0x41). The μ P must wait until this bit is reset before sending the next command.

Missing addresses in the HEX file must not be loaded. The "Write Program Memory Command" must be repeated until the program code is fully loaded. The end of the code segment inside the HEX file is the change from C: (code) to D: (data). This is the start of the data segment, which is needed for the Data Boot, described in the next step.

After all the code has been loaded, the "Finish Boot" command must be sent:

MCMD = 0x1F

4.8.7 Reset Execution and Boot Strap Pin Setting

The reset is executed via low signals on the DELIC RESET pin (29) and the VIP RESET pin (44). It is recommended to connect the VIP RESET inputs to the DELIC RESIND output pin (89). The RESIND signal is a delayed reset signal and stays at least 500 us after termination of the DELIC RESET input. This mechanism ensures that all output clocks of the DELIC have become stable even after a short reset was applied. Connecting the VIP reset to this RESIND signal ensures stable VIP clocking after reset (Layer1 clock, DCL2000, FSC).

Together with applying the reset signal to the DELIC, the strap pin signals must be defined. There are 9 pins at the DELIC device which have a special functionality. These so called strap pins are used as inputs while reset is active and determine different modes like master/slave mode of the PCM interface, test modes, boot mode,... Please refer to [page 38](#) for detailed information about the strap pin options.

The settings of the strap signals are sampled with the rising edge of the DELIC RESET input signal. For a μ P- boot, the default settings of strap 4 (emulation boot) and strap 6 (boot strap) are needed.

After a correct reset execution and strap pin setting, the DELIC sends the command "Start Loading Program RAM" to the uP: OCMD = 0x1F

4.9 General Mailbox

4.9.1 Overview

The μ P and the DSP communicate via a bidirectional Mailbox according to the mailbox protocol described in **DELIC-LC/-PB Software User's Manual**. The DELIC provides two dedicated Mailboxes that may be used in two operational modes:

- **DMA mode** in which the two Mailboxes operate independently, one serves as a general purpose Mailbox and the other serves as a DMA Mailbox.
- **Expanded Mailbox mode** in which the two Mailboxes are regarded as a enlarged general purpose Mailbox, providing a double number of registers.

The general purpose Mailbox includes two separate parts:

- **μ P Mailbox** - enables transfers from the μ P to the OAK.
- **OAK DSP Mailbox** - enables transfers from the OAK to the μ P.

Both parts include a command register, 9 x (16-bit) registers (17 registers in expanded mode) and a busy bit. One of the data registers in every part has a special addressing mode, i.e. the OAK may access either a certain byte of a word or the whole word which is temporarily stored in the Mailbox. This requires to use 3 different addresses in OAK's direction.

*Note: The Mailbox protocol commands structure is described in **DELIC-LC/-PB Software User's Manual**.*

4.9.2 μ P Mailbox

The μ P Mailbox includes:

- Eight 16-bit data registers (MDTn)
- A 16-bit general register (MGEN)
- An 8-bit command register (MCMD)
- A 1-bit busy register (MBUSY)

Registers MDTn, MGEN and MCMD may be written by the μ P and read by the OAK. The MBUSY register may be written by the DSP and read by the μ P.

A write of the μ P to the MCMD-register of the μ P-mailbox generates an interrupt to the OAK. Thus, the user has to provide all mailbox data prior to writing to register MCMD.

The MBUSY **bit** which may be read by the μ P (register MBUSY) is set automatically after a write to the μ P command register (MCMD) and reset automatically by a direct OAK write operation to it.

*Note: The command Opcodes are defined in **DELIC-LC/-PB Software User's Manual**.*

Data Transfer from the μ P to the OAK

- The μ P reads the busy bit and checks whether the Mailbox is available (MBUSY='0')
- The μ P writes to the Data registers MDTn (optional)
- The μ P writes to the μ P Command register (MCMD), this write must be performed and sets automatically the μ P Mailbox busy bit (MBUSY).
- An OAK interrupt (INT2) is activated due to the write to the Command register (MCMD).
- The OAK INT2 routine reads MCMD and performs the command (the read of the command register resets the INT2 activation signal).
- When finished, the INT2 routine resets MBUSY for enabling the μ P to send the next command.

Note: The μ P may perform consecutive writes to the μ P Mailbox, and the user must guarantee that the data has been transferred to the OAK correctly (the busy bit has been reset) before writing new data to the μ P Mailbox.

4.9.3 OAK Mailbox

The OAK Mailbox includes:

- Eight 16-bit data registers (ODTx)
- A 16-bit general register (OGEN)
- An 8-bit command register (OCMD)
- A 1-bit busy register (OBUSY)

Registers ODTx, OGEN and OCMD may be written by the OAK and read by the μ P. The OBUSY bit may be written by the μ P and read by the OAK. In addition, the μ P can read this bit (because the μ P could poll this bit).

A write of the OAK to register OCMD of the OAK mailbox generates an interrupt to the μ P. Thus the OAK firmware provides all mailbox data prior to writing to register OCMD.

The OBUSY- bit which can be read by the OAK, is set automatically after a write of the OAK to register OCMD and is reset by a direct μ P write to it (when the μ P has finished reading the OAK Mailbox contents).

*Note: The Opcodes indications are defined in **DELIC-LC/-PB Software User's Manual**.*

Data Transfer from the OAK to the μ P

- The OAK reads the busy bit and checks whether the MB is available (OBUSY='0')
- The OAK writes to the data registers ODTn (optional)
- The OAK writes to the command register (OCMD). This write must be performed and automatically sets the OAK Mailbox busy bit (OBUSY)
- A μ P interrupt is activated due to the write operation to the register OCMD.
- The μ P reads the command register and performs the command.
- When finished, the μ P resets OBUSY for enabling the OAK to send the next command.

Note: The OAK may perform consecutive writes to the OAK Mailbox and the OAK firmware guarantees that the data has been transferred to the μ P correctly (OBUSY reset) before writing new data to the OAK Mailbox.

4.10 DMA Mailbox (DELIC-PB only).

The DELIC provides two dedicated mailboxes that may be used in two different ways:

1. In DMA mode, one may be used as a DMA mailbox (16 bytes) and one as general purpose mailbox (16 bytes). Both mailboxes operate independently.
2. In Expanded Mailbox mode, the two mailboxes are regarded as one large general purpose mailbox, providing double number of registers (32 bytes).

The mailbox mode can be configured in the configuration register (MCFG:DMA).

The 16-byte deep DMA mailbox connects the DELIC and an external DMA controller. The DMA mailbox can be accessed only by the DMA controller and only upon a request from DELIC.

Note: The μ P can not access the DMA mailbox. It can access directly only the General Mailbox.

The DMA mailbox can be used for different data transfers, e.g.:

- Data transfer via GHDLC (e.g. 2 Mbit/s)
- Transfer of D-channel signaling data (16 kbit/s)
- Recording and replay of voice channels (64 kbit/s)
- Fast data transfers between external and DELIC internal memories

The DMA mailbox consists of two separate parts:

- Transmit mailbox - for DMA data transfer from memory to DELIC.
- Receive mailbox - for DMA data transfer from DELIC to memory.

In order to transmit data, the DELIC must initiate a DMA Request for Transmit data (DREQT); for receiving data, it initiates DREQR. The DMA controller answers with DMA Acknowledge (DACK) signal together with RD or WR signal (Intel/Infineon bus type), or R/W and DS (Motorola bus type). Which signals are used depends on the selected

DMA mode, and the data transfer direction.

Two DMA modes are supported:

- Two-cycle DMA transfer mode called also Memory-to-memory mode
- Single cycle DMA transfer mode called also Fly-by mode

An example for a two-cycle DMA transfer in receive direction (data is read from DELIC and written to memory) in Intel/Infineon Mode is shown in **Figure 52**.

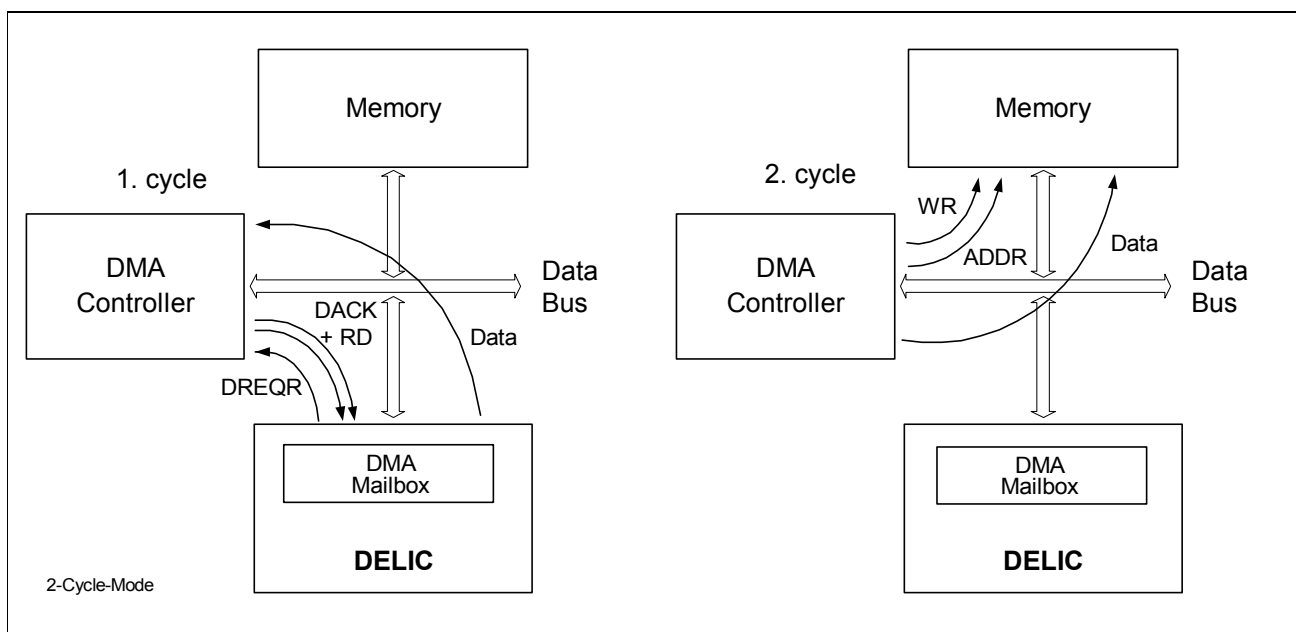

Figure 52 Two-cycle DMA Transfer Mode for Receive Direction

1. The DMA mailbox contains data (the receive mailbox contains up to 16 bytes of data)
2. DELIC requests DMA service via DREQR
3. DMA controller issues a DMA Acknowledge (DACK) signal for addressing the DMA mailbox and a "read" signal for indicating DELIC that it will read the receive mailbox
4. The DMA controller reads the data into an on-chip register (= end of first cycle).
5. The DMA controller writes the data into the memory using ADDR and WR (= second cycle).

The main advantage of the two-cycle DMA transfer mode, compared to general mailbox access by a μ P, is its faster response time (depends on the operating system) and a simple data flow control.

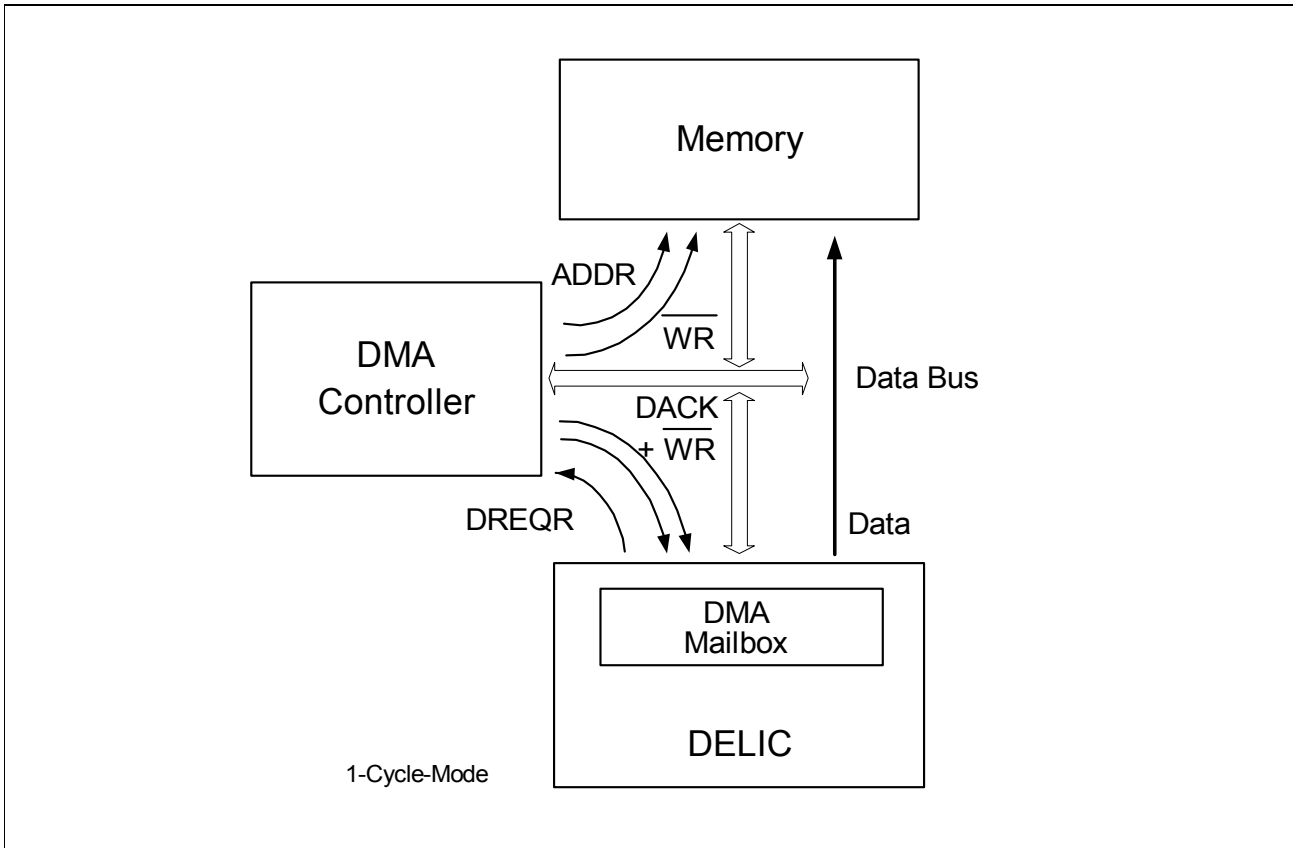

Figure 53 Single cycle DMA transfer mode for Receive Data

Example for a single-cycle DMA transfer mode in receive direction (data is read from DELIC and written to memory) in Intel/Infineon Mode. **Figure 53:**

1. The DMA mailbox contains data (the receive mailbox contains up to 16 bytes of data)
2. DELIC requests DMA service via DREQR
3. DMA controller issues a DMA Acknowledge (DACK) signal for addressing the DMA mailbox and a "read" signal for indicating DELIC that it will read the receive mailbox
4. In parallel, when the read data are stable on the bus, the DMA controller writes the data directly into the memory using ADDR and WR.

Note: In Intel/Infineon Mode, WR is used as "read" signal for the receive mailbox.

An example for a single-cycle DMA transfer in Intel/Infineon mode in transmit direction (data is read from memory and written into DELIC) is shown in **Figure 54:**

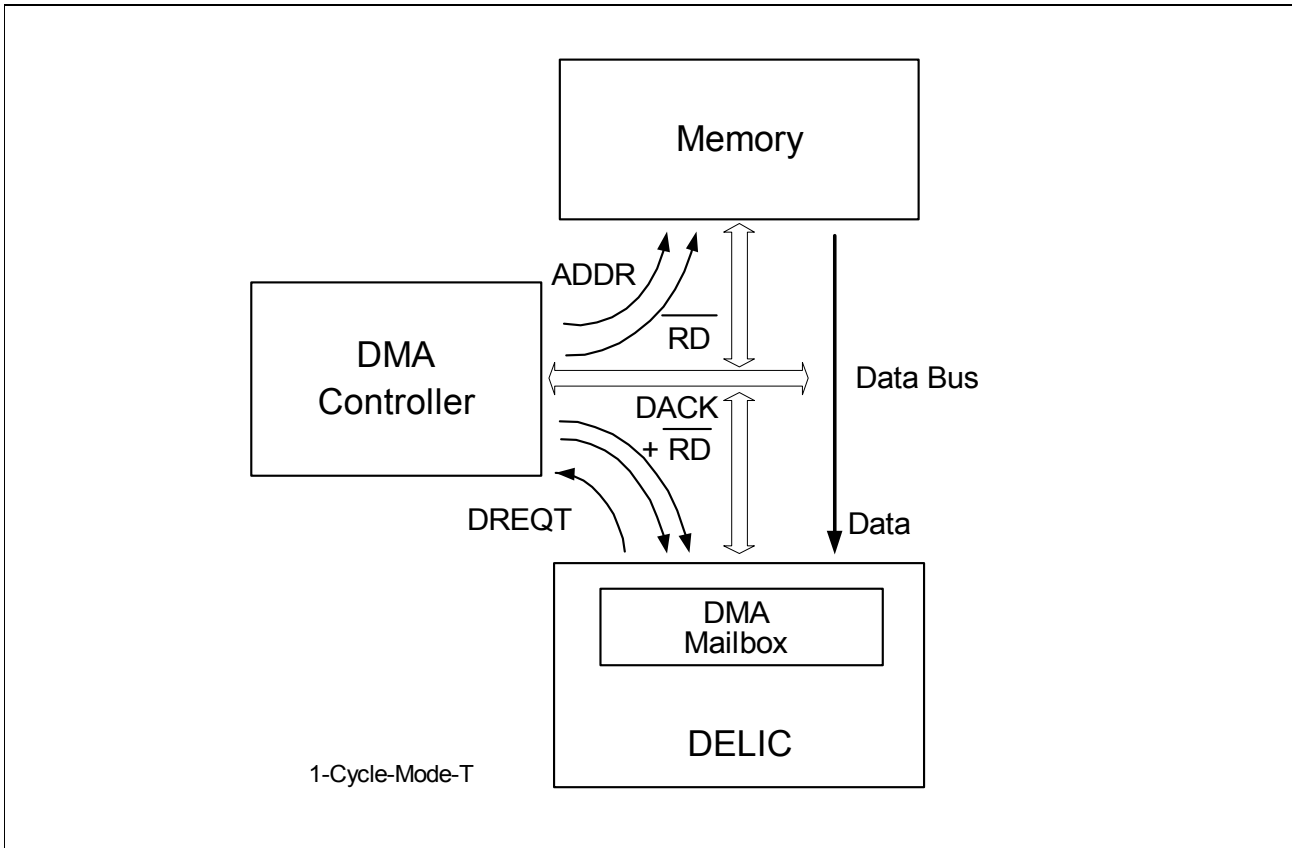

Figure 54 Single cycle DMA transfer mode for Transmit Data

1. The DMA transmit mailbox is empty
2. DELIC requests DMA service via DREQT
3. The DMA controller addresses memory with ADDR and the DELIC with DACK
4. With read signal (RD), memory data reach the data bus
5. In parallel, when the data are stable on the bus, the DMA controller writes it directly into the transmit mailbox.

Note: In Intel/Infineon Mode, RD is used as write signal for the transmit mailbox.

4.10.1 DMA Handshake

In transactions between DMA controller and DELIC, the DELIC indicates that it is ready to transmit/ receive data by setting DREQT / DREQR high. The DMA controller answers by driving $\overline{\text{DACK}}$ low. $\overline{\text{DACK}}$ acts like a CS and remains low during the entire transaction. By driving DACK high, the DMA controller can stop the transaction on any stage, even if the data transfer has not been finished yet.

DELIC Programming

1. Set the DMA transfer mode in MCFG register by the μP to Memory-to-Memory or Fly-by mode.

Functional Description

2. Select the type of used data bus via DELIC pin "MODE": Intel/ Infineon or Motorola
3. Set byte count by writing the number of bytes to be transferred, minus 1, into DTXCNT/DRXCNT register (is handled by the OAK firmware).
4. Et the end of a transaction, OAK INT0 is automatically activated (if not masked) in order to indicate that the mailbox is empty and available for a next operation. The OAK can mask INT0 as a whole or just one of its components (for receive or transmit direction) via register DINSTA.

4.10.1.1 Two-cycle DMA Transfer Mode

Depending on the selected bus mode (Intel / Infineon or Motorola), different signals are used.

In Intel/Infineon mode, the control lines are \overline{DACK} , \overline{RD} , \overline{WR} . Driving \overline{RD} low when \overline{DACK} is low causes a read from the mailbox. Driving \overline{WR} low when \overline{DACK} is low causes a write into the mailbox.

In Motorola mode, the control lines are \overline{DACK} , R/\overline{W} , \overline{DS} . Driving R/\overline{W} high when \overline{DACK} and \overline{DS} are low causes a read from the mailbox. Driving R/\overline{W} low when \overline{DACK} and \overline{DS} are low causes a write into the mailbox.

4.10.1.2 Fly-by Mode

In Fly-by mode, the DMA transfer is done in one bus transaction. The DMA controller controls the DMA mailbox and the conventional memory within the same cycle; write strobe just when the read data is valid on the bus. See timing diagrams for Intel/Infineon and for Motorola bus type in [Chapter 8](#).

4.10.2 PEC Mode.

The PEC-mode supports Infineon μ Ps C16x, which use an integrated Peripherals Event Controller (PEC) as a DMA controller. This DMA controller is edge sensitive, meaning edges have to be provided on the DREQ line in order to initiate every DMA transfer.

DREQ is internally controlled by the Read/Write signals. \overline{WR} falling edge disables DREQT, i.e. drives it inactive, and \overline{RD} falling edge does the same for DREQT. Rising edges of these signals enable DREQs again.

4.10.3 Transmit DMA Mailbox

The Transmit DMA mailbox includes:

- A 16-byte FIFO which the DMA controller writes in (addresses TDT0-7) and the OAK reads out as from 8 regular 16-bit-wide registers.
- A 4-bit counter for indicating the number of transfers remaining in the current transaction (register DTXCNT).

Functional Description

- A 4-bit Interrupt status register (DINSTA), which actually belongs to both directions - Transmit and Receive.

The DELIC initiates all transfers, i.e. each transmit is initiated by the OAK. But the transfers are carried out by the DMA controller.

If the DELIC transmits data e.g. to the GHDLIC unit, the OAK writes the requested number of bytes (minus 1) into the DTXCNT register which causes the assertion of DREQT (“DMA Request for Transmit direction”) pin.

The DMA controller grants the bus to the DELIC, it drives $\overline{\text{DACK}}$ low and begins toggling the control lines.

In Intel / Infineon (Memory-to-Memory) mode it drives $\overline{\text{WR}}$ line low when writing a byte to the mailbox. $\overline{\text{RD}}$ line stays high during all the “Write” transfer. $\overline{\text{DACK}}$ functions as a $\overline{\text{CS}}$ and is driven low during each “Write” access. Refer to AC specification, in [Chapter 8](#).

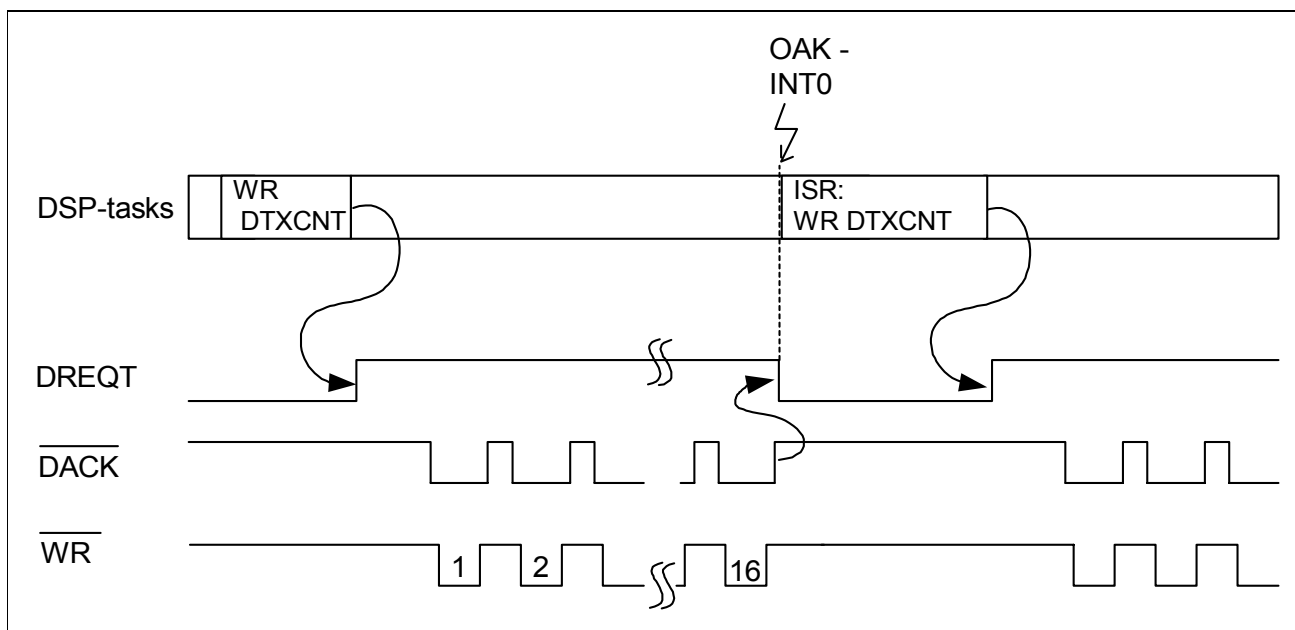

Figure 55 Timing in two-cycle DMA Mode for Transmit Direction and Infineon/Intel Bus Type

In Motorola (Memory-to-Memory) mode the DMA controller drives $\overline{\text{R/W}}$ line low during ‘Write’ operations when $\overline{\text{DACK}}$ is low and $\overline{\text{DS}}$ is used for access timing. In Fly-by mode the meaning of ‘Read’ and ‘Write’ commands is opposite for the mailbox ([see Chapter 4.10.1.2](#)). After every ‘Write’ operation the counter (DTXCNT) is decremented by one. DMA-operation is finished with the count down from ‘0_H’ to the value ‘F_H’.

The DMA controller can stop the transaction (before frame end) driving $\overline{\text{DACK}}$ high. The DELIC continues keeps DREQT active, stops decrementing DTXCNT and waits until $\overline{\text{DACK}}$ becomes low again.

Functional Description

After the DMA Controller has written the requested number of bytes to the transmit mailbox, DTXCNT becomes 'F_H', and DREQT is deasserted. Register DINSTA can be programmed to cause an interrupt (INT0) to the OAK.

The OAK can now read the data from the transmit mailbox:

- 1st byte in least significant (LS) byte of LS word of the FIFO
- 2nd byte in most significant (MS) byte of LS word of the FIFO, and so on

Note:

1. In case of an odd number of bytes, the last byte is available as the LS byte of the last word while the MS byte of this word is do not care.
2. The OAK reads data word-by-word, exactly like in a non-DMA transfer.

Data Transfer via the Transmit Mailbox - Steps

1. The OAK writes into DTXCNT the number of bytes to be transferred minus one (Tr_Num).
2. DREQT is asserted ("high" or "low" depending on register MCFG:DRQLV).
3. The DMA asserts $\overline{DACK} = 0$ and issues (Tr_Num+1) write transactions to the mailbox ("FIFO").
4. DREQT is deasserted ("low" or "high").
5. If bit DINSTA:TMSK is inactive ("1"), the DMA interrupt (INT0) of the OAK is activated.
6. The OAK reads Tr_Num bytes from the mailbox.

Note: The OAK must not write to the register DTXCNT while the previous DMA transfer has not been finished. (The OAK waits for Transmit DMA Interrupt and tests if DTXCNT equals 'F_H'.)

4.10.4 Receive DMA Mailbox

The receive mailbox includes:

- A 16-byte FIFO which the OAK writes into as in 8 regular 16-bit-wide registers and the DMA controller reads out like from a FIFO (RDT0-7).
- A 4-bit counter for indicating the number of transactions that remain for the transfer (DRXCNT).

The DELIC initiates all transfers, i.e. each receive is initiated by the OAK. But the transfers are done by the DMA controller.

When the DELIC receives data e.g. from the GHDLIC Unit, the OAK writes this data into the receive mailbox whereas the 1st byte is put into LS byte of LS word, the 2nd byte into MS byte of LS word, and so on.

Note: In case of an odd number of bytes, the MS byte of the last word is don't care.

Then the OAK writes the byte count into register DRXCNT, which causes the assertion of DREQR ("DMA Request for Receive direction") pin.

Functional Description

If the DMA controller grants the bus to the DELIC, it drives DACK low and begins toggling the control lines.

In Memory-to-Memory mode on Intel / Infineon bus type, it drives \overline{RD} line low when reading from the receive mailbox. The \overline{WR} line stays high during all the “Read” transfer. \overline{DACK} functions as a \overline{CS} and is driven low during each “Read” access.

In Memory-to-Memory mode on Motorola bus type, the DMAC drives R/ \overline{W} line ‘high’ during ‘Read’ operations while \overline{DACK} is low and \overline{DS} controls the read access. In Fly-by mode the meaning of ‘Read’ and ‘Write’ commands is opposite for the mailbox (see [Chapter 4.10.1.2](#)). After each ‘Read’ operation the counter (DRXCNT) is decremented by one. DMA-operation finishes with the count down from ‘0_H’ to the value ‘F_H’.

The DMA controller can stop the transaction (before frame end) driving \overline{DACK} high. The DELIC continues driving DREQR active, stops decrementing DRXCNT and waits until \overline{DACK} becomes low again.

After the DMA controller has read the requested number of bytes from the receive mailbox, DRXCNT becomes ‘F_H’, and DREQR is deasserted. DINSTA can be programmed to cause an interrupt (INT0) to the OAK.

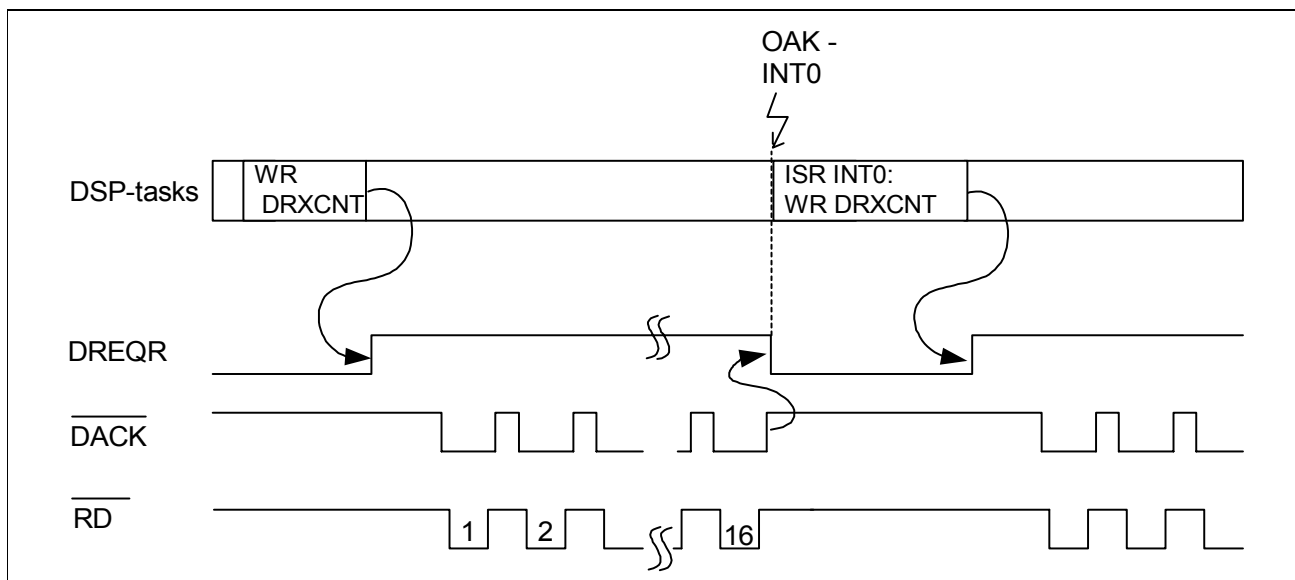

Figure 56 Timing in two-cycle DMA Mode for Receive Direction and Infineon/ Intel Bus Type

Receive Data via the Receive Mailbox-Steps

1. The OAK writes the received data to into the receive mailbox.
2. The OAK writes the number of bytes to be transferred minus one into DRXCNT (Rc_Num).
3. DREQR is asserted (“high” or “low”).

Functional Description

4. The DMA controller asserts $\overline{\text{DACK}}$ and issues (Rc_Num+1) read transactions from the receive mailbox ("FIFO").
5. DREQR is deasserted ("high" or "low").
6. If RMSK bit in DINSTA is inactive ("1"), the DMA interrupt to OAK (INT0) is activated.

Note: The OAK must not write to the register DRXCNT while the previous DMA receive transaction has not been finished. (The OAK waits for Receive DMA Interrupt and tests if DTXCNT equals 'F_H'.)

4.10.5 FIFO Access

The FIFO size is 16 bytes (8 words) each (Transmit, Receive). On the OAK side, each of the 8 data registers (TDT0-7 and RDT0-7) can be accessed separately. On the DMA controller side, only the current top of FIFO is accessible.

Note: The Transmit FIFO and the Receive FIFO are functioning as explained above only when the mailbox is in DMA mode (MCFG:DMA = '1'). In case of non-DMA mode (MCFG:DMA = '0') the FIFOs are used as secondary (extension) to the general mailbox, which means that the general mailbox will have 16 words for each direction (OAK and μ P), instead of 8.

4.11 Clock Generator

4.11.1 Overview

The DELIC clock generator provides all necessary clock signals for the DELIC and connected clock slave devices. The internal clocks are generated by two on-chip PLLs:

1. A digital controlled oscillator (DCXO) generates a 16.384 MHz clock from an external crystal.
2. A PLL multiplies the 16.384 MHz clock to a 61.44 MHz clock.

An overview of the clock signals and a block diagram is shown below.

Table 43 Overview of Clock Signals

Pin	Function	I/O	During Reset
CLK16-XI	16.384 MHz External Crystal Input	I	I
CLK16-XO	16.384 MHz External Crystal Output	O	O
XCLK	External Reference Clock from layer-1 IC (2.048 MHz, 1.536 MHz or 8 kHz)	I	I (1.536 MHz)
REFCLK	PCM Reference Clock (8 kHz or 512 kHz)	I/O	tristate
PFS	PCM Frame Synchronization 8 kHz (I/O) or 4 kHz (I)	I/O	I (Slave) O (Master)
PDC	PCM Data Clock (2.048, 4.096, 8.192 or 16.384 MHz)	I/O	I (Slave) O (Master) (2.048 MHz)
CLKOUT	Auxiliary Clock (2.048, 4.096, 8.192, 16.384, or 15.36 MHz)	O	O (4.096 MHz)
DCL_2000	IOM-2000 Data Clock (3.072, 6.144 or 12.288 MHz)	O	O (3.072 MHz)
DCL	IOM-2 Data Clock (384 kHz, 768 kHz, 2.048 MHz or 4.096 MHz)	O	O (384 kHz)
FSC	IOM-2 and IOM-2000 Frame Synchronization 8 kHz.	O	O
L1_CLK	Layer-1 Clock 15.36 or 7.68 MHz (e.g. OCTAT-P / QUAT-S)	O	O (7.68 MHz)
DSP_CLK	DSP Test Clock. (to run the DSP at clock rates other than 61.44 MHz)	I	I

Functional Description

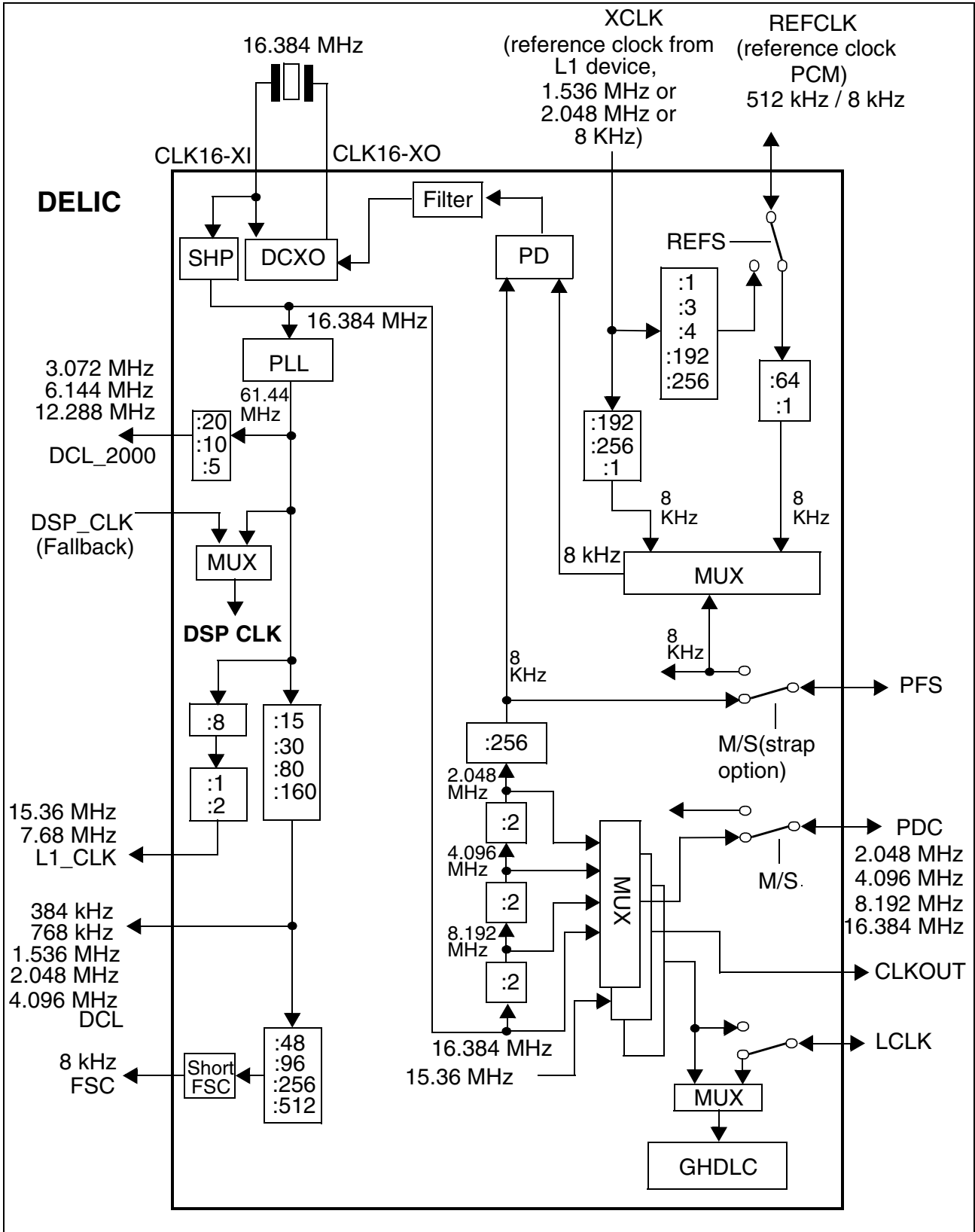

Figure 57 DELIC Clock Generator

4.11.2 DSP Clock Selection

The default DSP clock is the internal 61.44 MHz generated by the PLL. For test purpose, a different frequency may be provided via DSP_CLK input pin. The selection between the internal 61.44 MHz or external clock source is done by the DSP_FRQ input pin.

4.11.3 PCM Master/Slave Mode Clocks Selection

In PCM Master mode, the PFS and PDC are derived from the internal 16.384 MHz signal, and driven to the PCM interface via the PFS pin (output) and PDC pin (output). In PCM Slave mode, the PFS and PDC are generated from an external signal, and input to the DELIC via the PFS pin and the PDC pin.

Note: During reset, a strap pin determines whether the DELIC operates in clock Master or Slave mode. When setting to slave mode the register PFS SYNC ([Chapter 6.2.11.10](#)) has to be written in order to align the clocks.

4.11.4 DELIC Clock System Synchronization

The PCM clock division chain is synchronized to an external reference clock, used as one of the inputs to a phase comparator, after being divided into 8 KHz. The other phase comparator input is the 8 KHz clock, derived from the 16.384 MHz clock. The phase comparator output is used as control input of the DCXO, after being filtered by a low-pass filter. The reference clock can be driven by one of the following input pins:

- XCLK - 2.048 MHz, 1.536 MHz or 8 KHz:
Can be driven by a layer-1 transceiver (e.g. VIP, QUAT-S) connected to the Central Office. Only a clock master DELIC can be synchronized directly according to this input. In other cases (clock slave DELIC), this input signal may be divided to 8 KHz or 512 KHz, and driven out via REFCLK, in purpose to be used for the synchronization of the clock-master DELIC.
- REFCLK - 512 KHz or 8 KHz:
Used for synchronization of the clock master DELIC, when not synchronized by XCLK. Usually this signal is driven by a clock slave DELIC, or another PBX in the system. In a clock slave DELIC this pin is used as output.
- PFS - 8 KHz:
Driven by the system clock master. May be used for synchronization of the clock slave DELICs. In a clock master DELIC this pin is used as output.

4.11.5 IOM-2 Clock Selection

The IOM-2 interface clocks FSC and DCL are always output.

The FSC output signal is usually generated with 50% duty cycle. A short FSC pulse is required for multiframe start indication (one DCL cycle long). One cycle after the short FSC pulse, the normal FSC is generated again with 50% duty cycle.

4.11.6 IOM-2000 Clock Selection

The IOM-2000 interface uses the same FSC like IOM-2, whereas the data clock DCL2000 is a dedicated pin (always output).

4.11.7 REFCLK Configuration

REFCLK is an I/O pin for synchronizing the PCM interface (to 8 kHz or 512 kHz).

The clock master DELIC may synchronize the internal clocks to REFCLK by selecting REFCLK as the reference clock source.

A clock slave DELIC may use REFCLK as output, when REFCLK is driven by the XCLK input pin. The slave DELIC may transfer the XCLK signal to the clock master DELIC, and enable the clock master to synchronize to a layer-1 device, which is connected to another DELIC in the system.

4.11.8 GHDLC Clock Selection

Any of the next signals may be provided to the GHDLC channel as input clock:

1. LCLK Input Pin

This option is possible only when a LNC interface is assigned to the GHDLC unit.

2. 2.048 MHz, 4.096 MHz, 8.192 MHz or 16.384 MHz

These clock signals are generated internally by the PCM clocking path. The selected internal clock is also driven outward via LCLK.

Note: One of these signals must be selected as the clock of the GHDLC channel when the DELIC is the clock master of this channel.

Note: It's not possible to operate a GHDLC-channel with 16.384 MHz. However if the respective port isn't used this clock can be driven externally.

5 DELIC Memory Structure

The following tables provide the DELIC memory map for the DSP and the μ P.

5.1 DSP Address Space

5.1.1 DSP Register Address Space

Table 44 DSP Registers Address Space

Address	Description
D000 - D01F	DCU registers
D020 - D03F	A/ μ -law registers
D040 - D05F	IOMU registers
D060 - D07F	PCMU registers
D080 - D09F	Clocks registers
D0A0 - D0BF	TRANSIU registers
D0C0 - D0DF	GHDLC registers
D100 - D17F	μ P Mailbox and DMA Mailbox registers
D180 - D1FF	HDLCU registers
D1A0 - DFFF	not used

5.1.2 DSP Program Address Space

Table 45 DSP Program Address Space

Address	Size	Description
0000 - 0FFF	4Kw	Program RAM
1000 - F7FF	58Kw	Not used
F800 - FFFF	2Kw	Program ROM

5.1.3 DSP Data Address Space

Table 46 Occupied DSP Data Address Space

Address	Size	Description
0000 - 03FF	1Kw	Internal XRAM
2000 - 203F	64w	GHDLC data buffer
2040 - 207F	64w	reserved for test (**)
4000 - 401F	32w	HDLCU receive output buffer
4020 - 403F	32w	HDLCU transmit input buffer
4040 - 405F	32w	HDLCU command RAM
4060 - 407F	32w	HDLCU receive input buffer
4080 - 409F	32w	HDLCU transmit output buffer
40A0 - 40BF	32w	HDLCU status buffer
6000 - 605F	96w	TRANSIU receive data buffer
6080 - 60DF	96w	TRANSIU transmit data buffer
6100 - 61BF	192w	reserved for test (**)
6200 - 6248	72w	reserved for test (**)
6280 - 62C8	72w	reserved for test (**)
8000 - 803F	64w	IOMU receive data buffer
8040 - 807F	64w	IOMU transmit data buffer
8080 - 80FF	128w	reserved for test (**)
9000 - 9017	24w	HRAM for U _{PN} scrambler
9020 - 9037	24w	HRAM for U _{PN} descrambler
A000 - A07F	128w	PCMU receive data buffer
A080 - A0FF	128w	PCMU transmit data buffer
A100 - A1FF	256w	reserved for test (**)
D000 - DFFF	4Kw	OAK memory mapped registers(*)
E000 - E1FF	0.5Kw	A/ μ -Law ROM
F400 - F7EE	1Kw-16w	Emulation mail box (on SCDI)
F7F0 - F7FF	16w	OCEM [®] Registers
FC00 - FFFF	1Kw	Internal YRAM

DELIC Memory Structure

Note: (*) The OAK memory mapped registers address space is described in the following table:

(**) Accessing these addresses may cause unpredictable results.

Table 47 OAK Memory Mapped Registers Address Space

Address	Description
D000 - D01F	DCU registers
D020 - D03F	A/m-law registers
D040 - D05F	IOMU registers
D060 - D07F	PCMU registers
D080 - D09F	Clocks registers
D0A0 - D0BF	TRANSIU registers
D0C0 - D0DF	HDLCU registers
D100 - D17F	CPU+DMA mailbox registers
D180 - D1FF	GHDLC registers
D1A0 - DFFF	not used

For connecting a HDLC channel to a subscriber, the receive and transmit time slot address must be determined. Usually the HDLC channels perform signalling to a terminal which can be accessed via IOM2 or IOM2000 interface. Either D-channel handling (2 bit) or signalling via a B-channel (8 bit) can be selected. The following figures show the memory organization and help to determine initialization addresses for the HDLC software registers.

The TRANSIU receive and transmit buffers are accessed directly by the DSP: switching- and HDLC-tasks. Accesses to the 'Operation Mode Command and Status Bits' are possible via addresses: $6003_H + n * 4$ with $n = 0..23$.

DELIC Memory Structure

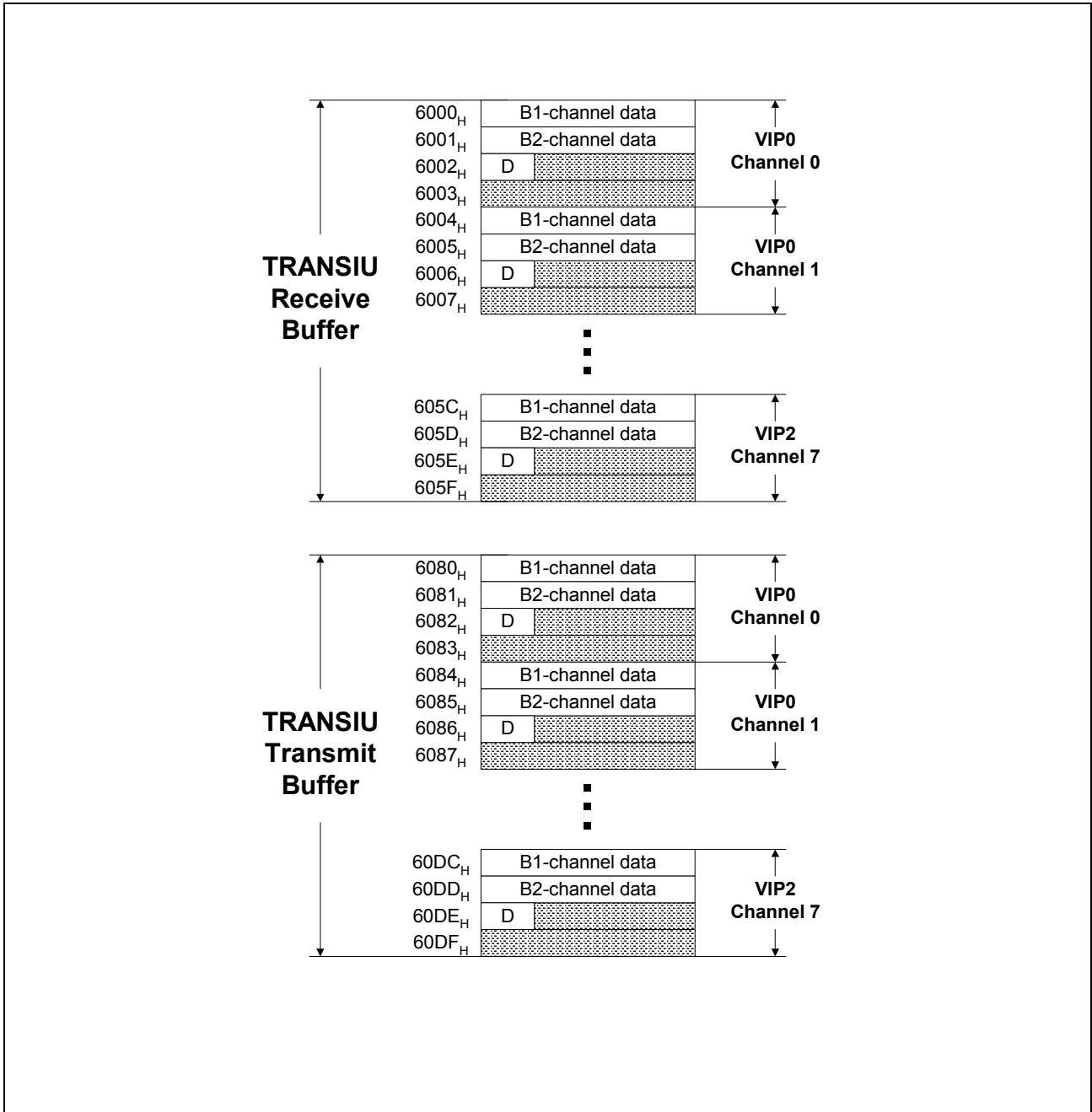

Figure 58 TRANSIU Buffer Addresses

5.2 μ P Address Space

The μ P address space consists of the general mail-box registers, the DMA mail-box registers (only in non-DMA mode), the μ P-interface control register, and the μ P-interface status register (MISR)

Table 48 μ P Address Space Table

Address	Description
00 _H - 43 _H 60 _H - 62 _H	μ P- mail box registers
48 _H , 68 _H , 6A _H	μ P-configuration registers
6B _H - 7F _H	Reserved. Accessing these addresses may cause unpredictable results

6 Register Description

6.1 Register Map

Table 49 TRANSIU Register Map

Reg Name	Access	Address	Reset Value	Comment	Page No.
TICR	RD/WR	D0A0 _H	0000 _H	IOM-2000 global configuration	161
TCCR0	RD/WR	D0A1 _H	FFFF _H	Channel 7..0 configuration	162
TCCR1	RD/WR	D0A2 _H	FFFF _H	Channel 15..8 configuration	162
TCCR2	RD/WR	D0A3 _H	FFFF _H	Channel 23..16 configuration	162
VIPCMR0	WR	D0A8 _H	0000 _H	VIP_0 command registers	164
VIPCMR1	WR	D0A9 _H	0000 _H	VIP_1 command registers	164
VIPCMR2	WR	D0AA _H	0000 _H	VIP_2 command registers	164
VIPSTR0	RD	D0AC	0000 _H	VIP_0 status register	167
VIPSTR1	RD	D0AD _H	0000 _H	VIP_1 status register	167
VIPSTR2	RD	D0AE _H	0000 _H	VIP_2 status register	167
TICCMR	WR	D0B0 _H (LS-word) D0B1 _H (MS-word)	0000 _H 0000 _H	Channel initialization command	168
TICSTR	RD	D0B2 _H (LS-word) D0B3 _H (MS-word)	0000 _H 0000 _H	Channel initialization status	173
TUTLR	RD/WR	D0B4 _H (LS-word) D0B5 _H (MS-word)	0000 _H 0000 _H	Up test loop register	174

Register Description

Table 50 Scrambler Register Map

Reg Name	Access	Address	Reset Value	Comment	Page No.
SCMOD	RD/WR	D010 _H	0003 _H	Scrambler mode	175
SCSTA	RD/WR	D011 _H	undef.	Scrambler status	176

Table 51 IOMU Register Map

Reg Name	Access	Address	Reset Value	Comment	Page No.
ICR	R/W	D040 _H	0002 _H	IOMU Control	177
ISR	R	D041 _H	undef.	IOMU Status	178
ITSCR	Set (W)	D042 _H	0000 _H	IOMU Tri-State Control	179
	Reset (W)	D043 _H			
	R	D044 _H			
IDRDYR	R	D045 _H	undef.	IOMU DRDY	181
IDPR	R/W	D046 _H	00E0 _H	IOMU Data Prefix	182

Table 52 PCMU Register Map

Reg Name	Access	Address	Reset Value	Comment	Page No.
PCR	RD/WR	D060 _H	00 _H	PCMU Control	183
PSR	RD	D061 _H	undef.	PCMU Status	184
PTSC0	RD/WR	D062 _H (read/set) D063 _H (read/reset)	00 _H	PCMU Tristate control 0	185
PTSC1	RD/WR	D064 _H (read/set) D065 _H (read/reset)	00 _H	PCMU Tristate control 1	185
PTSC2	RD/WR	D066 _H (read/set) D067 _H (read/reset)	00 _H	PCMU Tristate control 2	185

Register Description

Table 52 PCMU Register Map (cont'd)

Reg Name	Access	Address	Reset Value	Comment	Page No.
PTSC3	RD/WR	D068 _H (read/set) D069 _H (read/reset)	00 _H	PCMU Tristate control 3	185
PTSC4	RD/WR	D06A _H (read/set) D06B _H (read/reset)	00 _H	PCMU Tristate control 4	185
PTSC5	RD/WR	D06C _H (read/set) D06D _H (read/reset)	00 _H	PCMU Tristate control 5	185
PTSC6	RD/WR	D06E _H (read/set) D06F _H (read/reset)	00 _H	PCMU Tristate control 6	185
PTSC7	RD/WR	D070 _H (read/set) D071 _H (read/reset)	00 _H	PCMU Tristate control 7	185
PDPR	RD/WR	D072 _H	E0 _H	PCMU Data Prefix	187

Table 53 A-/μ-Law Unit Register Map

Reg Name	Access	Address	Reset Value	Comment	Page No.
AMCR	R/W	D020 _H	00 _H	A/μ-law Unit Control	188
AMIR	W	D021 _H	undefined	A/μ-law Unit Input	189
AMOR	R	D022 _H	undefined	A/μ-law Output	190

Register Description

Table 54 HDLCU Register Map

Reg Name	Access	Address	Reset Value	Comment	Page No.
HCR	W	D180 _H	0001 _H	HDLC Control	191
HSTA	R	D180 _H	0001 _H	HDLC Status	192
HCCV	R/W	4040 _H -405F _H	undefined	Channel Command Vector	193
HCSV	R	40A0 _H -40BF _H	undefined	Channel Status Vector	195

Table 55 GHDLIC Register Map

Reg Name	Access	Address	Reset Value	Comment	Page No.
GTEST	W	D0C0 _H	0001 _H	GHDLIC Test/ Normal Mode	197
GCHM	W	D0C1 _H	0000 _H	GHDLIC Channel Mode	198
GINT	R	D0D4 _H	0000 _H	GHDLIC Interrupt	199
GFINT	R/W	D0D3 _H	0000 _H	GHDLIC Frame Interrupt	200
GRSTA0	R	D0C2 _H	001F _H	GHDLIC Receive Status cha. 0	201
GRSTA1	R	D0C3 _H	001F _H	GHDLIC Receive Status cha. 1	201
GRSTA2	R	D0C4 _H	001F _H	GHDLIC Receive Status cha. 2	201
GRSTA3	R	D0C5 _H	001F _H	GHDLIC Receive Status cha. 3	201
RXDAT	RD	2000 _H -203F _H	0000 _H	Receive data and status	203
GMOD0	W	D0C6 _H	0140 _H	GHDLIC Mode cha. 0	204
GMOD1	W	D0C7 _H	0140 _H	GHDLIC Mode cha. 1	204
GMOD2	W	D0C8 _H	0140 _H	GHDLIC Mode cha. 2	204
GMOD3	W	D0C9 _H	0140 _H	GHDLIC Mode cha. 3	204
GTCMD0	W	D0CA _H	0000 _H	GHDLIC TX Command cha. 0	206
GTCMD1	W	D0CC _H	0000 _H	GHDLIC TX Command cha. 1	206
GTCMD2	W	D0CE _H	0000 _H	GHDLIC TX Command cha. 2	206
GTCMD3	W	D0D0 _H	0000 _H	GHDLIC TX Command cha. 3	206
GASYNC	R/W	D0D2 _H	0000 _H	ASYNC Control/ Status	207
GLCLK0	R/W	D08A _H	0000 _H	LCLK0 Control Register	208

Register Description

Table 55 GHDLC Register Map (cont'd)

Reg Name	Access	Address	Reset Value	Comment	Page No.
GLCLK1	R/W	D08B _H	0000 _H	LCLK1 Control Register	209
GLCLK2	R/W	D08C _H	0000 _H	LCLK2 Control Register	210
GLCLK3	R/W	D08D _H	0000 _H	LCLK3 Control Register	211
MUXCTRL	R/W	D14A _H	0000 _H	Multiplexer Control	212
ST2	W	OAK register	xxxx xx0x xxxx xxxx _B	GHDLCU frame frequency	213

Table 56 DCU Register Map

Reg Name	Access	Address	Reset Value	Comment	Page No.
IMASK	R/W	D002 _H	0000 _H	Interrupt Mask	214
STEVE	R	D003 _H	0000 _H	Status Event	215
STATC	R	D004 _H	unchan.	Statistics Counter	216
STATI	R	D005 _H	0000 _H	Statistics	217

Table 57 μ P Configuration Register Map

Reg. (16 bit)	Description	Reset Value	Bit	DSP Word Access	μ P Byte Access	μ P-Addr. MSB of Word	μ P-Addr. LSB of Word	DSP Addr.	Page No.
MCFG	configuration	0 _H	6	R	R/W	none	48 _H	D148 _H	218
IVEC	int vector reg	unchanged	8	R/W	R	none	68 _H	D168 _H	220

Table 58 General Mailbox Register Map

Register (16 bit)	Description	Reset Value	Bit	DSP Word Access	μP Byte Acc.	μP-Addr. MSB of Word	μP-Addr. LSB of Word	DSP Addr.	Page No.
MCMD	μP command	00 _H	8	R	W	none	40 _H	D140 _H	221
MBUS Y	μP MB busy	0 _H	1	W	R	41 _H	none	D141 _H	222
MGEN	μP generic data reg.	unchanged	16	R	W	43 _H	42 _H	D142 _H (LSB) D143 _H (MSB) D144 _H (All)	223
MDT0	μP data reg0	unchanged	16	R	W	01 _H	00 _H	D100 _H	224
MDT1	μP data reg1	unchanged	16	R	W	03 _H	02 _H	D102 _H	224
MDT2	μP data reg2	unchanged	16	R	W	05 _H	04 _H	D104 _H	224
MDT3	μP data reg3	unchanged	16	R	W	07 _H	06 _H	D106 _H	224
MDT4	μP data reg4	unchanged	16	R	W	09 _H	08 _H	D108 _H	224
MDT5	μP data reg5	unchanged	16	R	W	0B _H	0A _H	D10A _H	224
MDT6	μP data reg6	unchanged	16	R	W	0D _H	0C _H	D10C _H	224
MDT7	μP data reg7	unchanged	16	R	W	0F _H	0E _H	D10E _H	224
OCMD	DSP command	00 _H	8	W	R	none	60 _H	D160 _H	225
OBUS Y	DSP MB busy	0 _H	1	R	R/W	61 _H	none	D161 _H	226

Register Description

Table 58 General Mailbox Register Map (cont'd)

Register (16 bit)	Description	Reset Value	Bit	DSP Word Access	µP Byte Acc.	µP-Addr. MSB of Word	µP-Addr. LSB of Word	DSP Addr.	Page No.
OGEN	DSP generic data reg	unchanged	16	W	R	63 _H	62 _H	D162 _H (LSB) D163 _H (MSB) D164 _H (All)	227
ODT0	DSP data reg0	unchanged	16	W	R	21 _H	20 _H	D120 _H	228
ODT1	DSP data reg1	unchanged	16	W	R	23 _H	22 _H	D122 _H	228
ODT2	DSP data reg2	unchanged	16	W	R	25 _H	24 _H	D124 _H	228
ODT3	DSP data reg3	unchanged	16	W	R	27 _H	26 _H	D126 _H	228
ODT4	DSP data reg4	unchanged	16	W	R	29 _H	28 _H	D128 _H	228
ODT5	DSP data reg5	unchanged	16	W	R	2B _H	2A _H	D12A _H	228
ODT6	DSP data reg6	unchanged	16	W	R	2D _H	2C _H	D12C _H	228
ODT7	DSP data reg7	unchanged	16	W	R	2F _H	2E _H	D12E _H	228

Note: MDT8..15 and ODT8..15 are accessible only in non-DMA mode, when the DMA Mailbox data registers are used for doubling the size of General Mailbox.

Register Description

Table 59 DMA Mailbox Register Map

Register	Description	Reset Value	Bit	DSP Access	DMA / μ P Acc.	μ P MSB Addr.	μ P LSB Addr.	DSP Addr.	Page No.
DTXCNT	Tx counter	0 _H	4	R/W	none	none	none	D150 _H	229
DINSTA	DMA Int status	0 _H	4	R	none	none	none	D152 _H	231
TDT0/MDT8	Tx data reg0/ μ P data reg8	unchanged	16	R	W	11 _H	10 _H	D110 _H	224
TDT1/MDT9	Tx data reg1/ μ P data reg9	unchanged	16	R	W	13 _H	12 _H	D112 _H	224
TDT2/MDT10	Tx data reg2/ μ P data reg10	unchanged	16	R	W	15 _H	14 _H	D114 _H	224
TDT3/MDT11	Tx data reg3/ μ P data reg11	unchanged	16	R	W	17 _H	16 _H	D116 _H	224
TDT4/MDT12	Tx data reg4/ μ P data reg12	unchanged	16	R	W	19 _H	18 _H	D118 _H	224
TDT5/MDT13	Tx data reg5/ μ P data reg13	unchanged	16	R	W	1B _H	1A _H	D11A _H	224
TDT6/MDT14	Tx data reg6/ μ P data reg14	unchanged	16	R	W	1D _H	1C _H	D11C _H	224
TDT7/MDT15	Tx data reg7/ μ P data reg15	unchanged	16	R	W	1F _H	1E _H	D11E _H	224
DRXCNT	Rx counter	0 _H	4	R/W	none	none	none	D170 _H	230
RDT0/ODT8	Rx data reg0/ DSP data reg8	unchanged	16	W	R	31 _H	30 _H	D130 _H	228

Register Description

Table 59 DMA Mailbox Register Map (cont'd)

Register	Description	Reset Value	Bit	DSP Access	DMA / μ P Acc.	μ P MSB Addr.	μ P LSB Addr.	DSP Addr.	Page No.
RDT1/ ODT9	Rx data reg1/ DSP data reg9	unchanged	16	W	R	33 _H	32 _H	D132 H	228
RDT2/ ODT10	Rx data reg2/ DSP data reg10	unchanged	16	W	R	35 _H	34 _H	D134 H	228
RDT3/ ODT11	Rx data reg3/ DSP data reg11	unchanged	16	W	R	37 _H	36 _H	D136 H	228
RDT4/ ODT12	Rx data reg4/ DSP data reg12	unchanged	16	W	R	39 _H	38 _H	D138 H	228
RDT5/ ODT13	Rx data reg5/ DSP data reg13	unchanged	16	W	R	3B _H	3A _H	D13A H	228
RDT6/ ODT14	Rx data reg6/ DSP data reg14	unchanged	16	W	R	3D _H	3C _H	D13C H	228
RDT7/ ODT15	Rx data reg7/ DSP data reg15	unchanged	16	W	R	3F _H	3E _H	D13E H	228

Note: MDT8..15 and ODT8..15 are accessible only in non-DMA mode, when the DMA Mailbox data registers are used for doubling the size of General Mailbox.

Register Description

Table 60 Clock Generator Register Map

Reg Name	Access	Address	Reset Value	Comment	Page No.
CPDC	R/W	D080 _H	0000 _H	PDC Control	232
CPFS	R/W	D081 _H	0001 _H	PFS Control	233
CLKOUT	R/W	D082 _H	0008 _H	CLKOUT Control	234
CREFSEL	R/W	D083 _H	0000 _H	DCXO Reference Clock Selection	235
CREFCLK	R/W	D084 _H	0003 _H	REFCLK Control	236
CDCL2	R/W	D085 _H	0004 _H	DCL_2000 Control	236
CDCL	R/W	D086 _H	000B _H	DCL Control	238
CFSC	R/W	D087 _H	0002 _H	FSC Control	239
CL1CLK	R/W	D088 _H	0000 _H	L1_CLK Control	240
CPFSSY	R/W	D089 _H	0000 _H	PFS Synchronization Mode	241
CRTCNT	R	D08E _H	0000 _H	Real-time Counter	242
CSTRAP	R/W	D08F _H	xxxx xxxx xxxx xx10 _B	Strap Status Register	243

6.2 Detailed Register Description

6.2.1 TRANSIU Register Description

6.2.1.1 TRANSIU IOM-2000 Configuration Register

TICR Register read/write Address: D0A0_H
Reset value: 0000_H

Note: The reset value of bit 4KFSC is undefined, since this read-only bit is toggled every 250 μs.

15	14	13	12	11	10	9	8
x	x	x	x	x	x	x	x
7	6	5	4	3	2	1	0
x	x	x	4KFSC	CMDEN	DXEN	DR1	DR0

DR1..0 IOM-2000 Data Rate and Channel Number

- 00 = 3.072 Mbit/s data rate; 8 IOM-2000 channels are supported
- 01 = 6.144 Mbit/s data rate; 16 IOM-2000 channels are supported
- 10 = 12.288 Mbit/s data rate; 24 IOM-2000 channels are supported
- 11 = Reserved

DXEN DX Line Enable

- 0 = IOM-2000 DX line to the VIP is in tri-state
- 1 = IOM-2000 DX line to the VIP is enabled (starting with the next 4 kHz frame)

CMDEN CMD Line Enable

- 0 = IOM-2000 CMD line to the VIP is in tri-state
- 1 = IOM-2000 CMD line to the VIP is enabled (starting with the next 4 kHz frame)

4KFSC 4 kHz FSC (read only)

- 0 = In the TRANSIU, the current 8 kHz IOM-2000 frame starts in the second half of the current 4 kHz U_{PN} of S/T frame
- 1 = In the TRANSIU, the current 8 kHz IOM-2000 frame starts in the first half of the current 4 kHz U_{PN} of S/T frame

Note: 'x' = unused (read as '0')

6.2.1.2 TRANSIU Channel Configuration Registers

The Channel registers are used for IOM-2000 channel disabling and mode programming. Each IOM-2000 channel may be programmed to U_{PN}, LT-S, or LT-T mode, or completely disabled.

Important

Only four channels out of eight channels are programmable to U_{PN} and S/T modes in VIP PEB 20590, the remaining four channels may be operated as U_{PN} transceiver only. It is the user's responsibility to ensure that the IOM-2000 channels in the TRANSIU are correctly configured in order to match with the line configuration of the VIP see below:

Table 61 Available ISDN Modes for Each VIP Channel

VIP_0,1,2 channel	0	1	2	3	4	5	6	7
TRANSIU channel	0 8 16	1 9 17	2 10 18	3 11 19	4 12 20	5 13 21	6 14 22	7 15 23
Available VIP Mode	U _{PN}	U _{PN} S/T	U _{PN}	U _{PN} S/T	U _{PN}	U _{PN} S/T	U _{PN}	U _{PN} S/T
Available VIP8 Mode	U _{PN} S/T	U _{PN} S/T	U _{PN} S/T	U _{PN} S/T	U _{PN} S/T	U _{PN} S/T	U _{PN} S/T	U _{PN} S/T

Registers TCCR0 - 2

read/write

Address:
TCCR0: D0A1_H
TCCR1: D0A2_H
TCCR2: D0A3_H

Reset values: FFFF_H

15	14	13	12	11	10	9	8
C7M(1:0)		C6M(1:0)		C5M(1:0)		C4M(1:0)	
7	6	5	4	3	2	1	0
C3M(1:0)		C2M(1:0)		C1M(1:0)		C0M(1:0)	

Register Description

- C7..0M(1:0) Operational Mode of IOM-2000 Channel7..0
- 00 = Channel is configured to S mode (LT-S)
 - 01 = Channel is configured to S mode (LT-T)
 - 10 = Channel is configured to U_{PN} mode
 - 11 = Channel is disabled, '0's are sent on the DX line

Note: TCCR0 (channel 7..0), TCCR1 (channel 15..8) and TCCR2 (channel 23..16) have the same structure, only TCRR1 is shown here.

Note: IOM-2000 cha. 0 and 1 are restricted to the modes LT-S and U_{PN}. This means that TCCR0:C0M1..0 and TCCR0:C1M1..0 must not be programmed to the value 01.

6.2.1.3 VIP Command Registers (VIPCMR0, VIPCMR1, VIPCMR2)

The VIPCMR0-2 registers contain command information dedicated to the VIP 0, 1, 2 (only the VIPCMR0 is shown here, VIPCMR1 and VIPCMR2 have the same structure).

VIPCMR Register

write

Address:

VIPCMR0:

D0A8_H

VIPCMR1:

D0A9_H

VIPCMR2_H:

D0AA_H

Reset value: 0000_H

15	14	13	12	11	10	9	8
x	x	x	x	RD _n	PLLPPS	SH_FSC	DELRE
7	6	5	4	3	2	1	0
DELCH(2:0)			EXREF	REFSEL (2:0)			WR _n

WR_n Write Command to VIP_n (S/T, U_{PN})

0 = Data sent to VIP_n is invalid

1 = Data sent to VIP_n is valid

REFSEL(2:0) Reference Clock Channel Select (LT-T)

The reference clock signal for the DELIC oscillator is generated from the internal VIP_n Channel_m coded in these 3 bits and passed on via pin REFCLK to the next cascaded VIP or directly to the DELIC

000 = Reference clock provided by Channel₀

001 = Reference clock provided by Channel₁

...

007 = Reference clock provided by Channel₇

EXREF External Reference Clock Selection (LT-T)

Register Description

	0 =	No external reference clock source. Reference clock is generated from internal VIP _n channel specified in REFCLK(2:0) and passed on via REFCLK pin to VIP _{n-1} or directly to DELIC.
	1 =	Reference clock is generated from external source via pin INCLK and passed on via REFCLK pin to VIP _{n-1} or directly to DELIC. The internal reference clock generation logic is disabled. Note that VIP ₀ has the highest priority in terms of clock selection
DELCH(2:0)		Delay Measurement Channel Selection (U _{PN}) Selects one of the eight U _{PN} line interface channels of each VIP where the delay is to be measured.
	000 =	Delay is measured in U _{PN} Channel_0
	001 =	Delay is measured in U _{PN} Channel_1
	...	
	111 =	Delay is measured in U _{PN} Channel_7
DELRE		Delay Counter Resolution (U _{PN}) Resolution of the delay counter.
	0 =	Resolution of 65 ns (15.36 MHz period)
	1 =	Resolution of 130 ns (7.68 MHz period)
		<i>Note: Using a resolution of 65 ns, the maximum delay of 20.8 μs is not covered (refer to DELAY(7:0) bits)</i>
SH_FSC		Short FSC Pulse
	0 =	The next FSC frame is no superframe
	1 =	The next FSC is assumed as superframe
PLLPPS		PLL Positive Pulse Sensing
	0 =	Normal operation
	1 =	The clock recovering PLLs of all VIP channels operate on positive line pulses only
RD _n		Read Request to VIP Status Register S _n (S/T, U _{PN})
	0 =	No register read

Register Description

- 1 = The DSP reads the VIP register (during initialization, debugging or error conditions). The register value is available for the read operation in the consecutive frame (after the next FSC).

Note: To avoid blocking, the DSP must not issue this bit during normal operation.

Note: Unused bits (x) read as '0'. The registers are reset upon every 8 kHz frame sync to avoid multiple data transmit/receive to/from the VIP.

6.2.1.4 VIP Status Registers

The VIPSTR0-2 registers contain the status bits received from the dedicated VIP for VIPs 0, 1, 2 respectively (all three registers have the same structure).

VIPSTR Register

read

Address:

VIPSTR0: D0AC_H,

VIPSTR1:

D0AD_H,

VIPSTR2: D0AE_H

Reset value: 0000_H

15	14	13	12	11	10	9	8
x	x	x	x	x	VIPVNR(1..0)		x
7	6	5	4	3	2	1	0
DELAY(7:0)							

DELAY(7:0) Line Delay Value (U_{PN})

Returns the value of the measured line delay (in μs) between the U_{PN} transmit and receive frame with a resolution of 65 ns or 130 ns (programmable in VIPCMR.DELRE bits).

The value indicates the delay between the transmitted M-bit and the received LF-bit (minus the U_{PN} guard time of 2 bits). The delay for one direction equals to the measured delay divided by two.

The channel address for the delay measurement is coded in VIPCMR.DELCH(2:0) bits.

The VIP provides 2 values in one U_{PN} frame (one every 125 μs) from which the bigger one is the valid.

Note: The transceiver delays of the VIP are included in the delay measurement.

VIPVNR(1..0) VIP Version Number

0 = VIP version V1.1

1 = VIP version V2.1

Note: Unused bits (x) read as '0'.

6.2.1.5 TRANSIU Initialization Channel Command Register

The Initialization Channel Command Register contains the Command bits for VIP_n, Channel_m together with 5 bits of the VIP channel address.

The VIP only acts upon the command bits if they were declared valid by the DELIC issuing a write command. Bit WR is dedicated to the command bits of groups CONF1, CONF2 and TST2, whereas WR_ST informs the VIP about changes in the layer 1 state machine of the DELIC (SMINI(2:0) and MSYNC bits).

The DELIC may also explicitly read the VIP's status information by issuing bit RD.

The reset value of each bit is '0' except bits MODE(2:0) which are set to '011'

Note: A read command to the VIP must not be issued during normal operation to avoid a loss of information when the VIP is reporting status information at the same time.

TICCMR Register

write

LS-word: D0B0_H,

Address:

MS-word: D0B1_H

Reset value: 0000_H

31	30	29	28	27	26	25	24
x	VIPADR(1:0)		CHADR(2:0)			FIL	EXLP
23	22	21	20	19	18	17	16
PLLS	PD	DHEN	x	FIL1	PDOWN	LOOP	TX_EN
15	14	13	12	11	10	9	8
PLLINT	AAC(1:0)		BBC(1:0)		OWIN(2:0)		
7	6	5	4	3	2	1	0
MF_EN	MODE(2:0)			MOSEL(1:0)		RD	WR

WR Write Command (S/T, U_{PN})

0 = Data sent in these bits is invalid

1 = All configuration bits contain valid data

Note: Does not apply to SMINI(2:0) and MSYNC bits

RD Read Request to VIP Command Bits (S/T, U_{PN})

0 = Normal operation

Register Description

1 = DELIC read request of the TICCMR register which was sent to the VIP. It includes initialization and configuration commands and the channel addresses. The VIP returns these values (instead of sending the actual VIP status information) within the IOM-2000 STAT_n_m bit stream. The values are available in the next frame (after next FSC) in DELIC TICSTR register.
Note: To avoid blocking, the DELIC must not issue this bit during normal operation.

MOSEL(1:0) Interface Mode Selection (S/T, U_{PN})

00 = Channel programmed to S/T mode
01 = Channel programmed to U_{PN} mode
10 = reserved
11 = reserved

MODE(2:0) Mode Configuration (S/T, U_{PN})

001 = Channel programmed to LT-T mode

Note: IOM-2000 cha. 0 and 1 are restricted to the modes LT-S and U_{PN}. This means that MODE(2..0) must not be programmed to the value 001 for these channels. Also see [Section 3.2.4.2](#) on [page 58](#).

011 = Channel programmed to LT-S mode (point-to-point or extended passive bus configuration) or U_{PN} mode

111 = Channel programmed to LT-S mode (short passive bus mode)

Note: All other states are reserved. The reset value is 011, e.g. the default mode of VIP is LT-S

MF_EN Multiframe Enable (S/T)

0 = Multiframe are disabled
1 = Multiframe are enabled

OWIN(2:0) Oversampling Window Size (S/T, U_{PN})

Specifies the width of the oversampling window in bit samples. The window is centered about the middle of the bit. For example, a size of 16 means that, upon detection of $(16/2) = 8$ times logical '1', the received bit is detected as '1'. The window size is programmed in steps of two as shown below:

000 = 2
001 = 4
010 = 6

Register Description

	...
	111 = 16
BBC(1:0)	Balancing Bit Control (U_{PN})
	00 = Adaptive generation of balancing bit (depending on line delay). upon reception of INFO3 or INFO4
	10 = Balancing bit control is disabled, and no balancing bit is added
	11 = Balancing bit control is disabled, and balancing bit is added after each code violation in the M-bit (INFO3 or INFO4)
AAC(1:0)	Adaptive Amplifier Control (S/T, U_{PN})
	00 = Adaptive amplifier control in VIP is enabled. The amplifier and the equalizer are switched on/off depending on the level of the received line signal with respect to the comparator threshold.
	10 = Adaptive amplifier control is disabled. The amplifier and the equalizer are switched off permanently.
	11 = Adaptive amplifier control is disabled. The amplifier and the equalizer are switched on permanently
PLLINT	Receive PLL Integrator (U_{PN})
	0 = Programmable deviation disabled
	1 = Programmable deviation enabled, i.e., the RxPLL reacts only after a certain number of consequent deviations from the PLL controlling range.
TX_EN	Transmitter Enable (S/T, U_{PN})
	0 = Transmitter (analog line driver) is disabled (e.g. for non- transparent analog loops in LT-T)
	1 = Transmitter is enabled (e.g. for switching of transparent analog loops in LT-S)
LOOP	Loop-back Mode in VIP Enable (S/T, U_{PN})
	0 = Loops disabled
	1 = Loop-back enabled. Channel_m transmit data is looped back to the receive data path (either transparent or non-transparent according to state of bit TX_EN). Depending on bit EXLP the loop is closed internally or externally.
	<i>Note: For U_{PN} additionally bit TUTLR:UTn has to be set to enable the test loop in the DELIC (n= IOM-2000 channel number)</i>
PDOWN	Power Down Mode (S/T, U_{PN})

Register Description

	0 =	Operational mode
	1 =	Channel_m in power-down mode (only the level detector in the VIP receiver is in operational mode)
DHEN		D-channel Handling Enable (LT-T)
	0 =	D-channel transmitted transparently, without any condition
	1 =	D-channel transmitted transparently if no collision is detected (E=D), if collision is detected (E ≠ D) '1s' are transmitted in D-channel
FIL1		Test Filter enable (applicable only in VIP V2.1 and higher versions)
	0 =	Test filter disable (default setting)
	1 =	Test filter enable (only for test purpose)
PD		Phase Deviation Selection (LT-T)
	0 =	Phase deviation = (2 bits - 2 oscillator periods + analog delay)
	1 =	Phase deviation = (2 bits - 4 oscillator periods + analog delay)
PLLS		Receive PLL Adjustment (S/T, U _{PN})
	0 =	tracking step equals 0.5 oscillator period
	1 =	tracking step equals 1.0 oscillator period
EXLP		External Loop (S/T, U _{PN})
	0 =	No external analog loop. If bit LOOP=1 the loop is closed internally
	1 =	External analog loop. If bit LOOP=1 the loop is closed externally
FIL		Filter Enable (U _{PN} only)
	0 =	Filter of equalizer inside the VIP receiver disabled
	1 =	Filter of equalizer inside the VIP receiver enabled
CHADR(2:0)		Channel_m Address for Commands
	000 =	Command word is dedicated to VIP_n Channel_0
	001 =	Command word is dedicated to VIP_n Channel_1
	010 =	Command word is dedicated to VIP_n Channel_2
	011 =	Command word is dedicated to VIP_n Channel_3
	100 =	Command word is dedicated to VIP_n Channel_4
	101 =	Command word is dedicated to VIP_n Channel_5
	110 =	Command word is dedicated to VIP_n Channel_6

Register Description

	111 =	Command word is dedicated to VIP_n Channel_7
VIPADR(2:0)		VIP_n Address for Commands
	00 =	Command word is dedicated to VIP_0
	01 =	Command word is dedicated to VIP_1
	10 =	Command word is dedicated to VIP_2
	11 =	Reserved

Note: Unused bits (x) read as '0'.

6.2.1.6 TRANSIU Initialization Channel Status Register (TICSTR)

The Initialization Channel Status Register contains the Command bits to VIP_n, Channel_m mirrored by the VIP in response to a read command issued by the DELIC in the previous frame.

Note: The actual Status information from the VIP channels is stored in the data RAM to make it accessible for the DELIC layer-1 state machine software in the DSP.

TICSTR Register

read Address:
LS-word: D0B2_H, MS-word: D0B3_H

Reset value: 0000_H

31	30	29	28	27	26	25	24
x	VIPADR(1:0)		CHADR(2:0)			FIL	EXLP
23	22	21	20	19	18	17	16
PLLS	PD	DHEN	x	x	PDOWN	LOOP	TX_EN
15	14	13	12	11	10	9	8
PLLINT	AAC(1:0)		BBC(1:0)		OWIN(2:0)		
7	6	5	4	3	2	1	0
MF_EN	MODE(2:0)			MOSEL(1:0)		RD	WR

6.2.1.7 Up Test Loop Register

The Up Test Loop Register allows to switch an analog loop in the VIP for test purposes.

TUTLR Register

read/ write

Address:

LS-word: D0B4_H, MS-word: D0B5_H

Reset value: 0000_H

31	30	29	28	27	26	25	24
x	x	x	x	x	x	x	x
23	22	21	20	19	18	17	16
UT(23:16)							
15	14	13	12	11	10	9	8
UT(15:8)							
7	6	5	4	3	2	1	0
UT(7:0)							

UT(n)

Up loop back bit for IOM-2000 channel n

0 = Up channel is set to normal mode

1 = Up channel is set to loop back test mode in the VIP

Note: When a channel is programmed to Up loop back test-mode, the TRANSIU expects the frame-start in the receive direction to be detected with very small delay after the frame-start in the transmit direction, and not after 125 us or more (as in normal work mode).

Note: To enable the loop in the VIP, additionally TICCMR:LOOP must be set to 1 for the respective channel.

6.2.1.8 Scrambler Mode Register

SCMOD Register

read/write

Address: D010_H

Reset value: 0003_H

15	14	13	12	11	10	9	8
x	x	x	x	x	x	x	x
7	6	5	4	3	2	1	0
x	x	x	x	x	SCMOD2	SCMOD1..0	

SCMOD1..0 Scrambling Mode of the U_{PN} Line Interface

00 = Scrambling according to ITU-T V.27

01 = Scrambling compatible to OCTAT-P PEB 2096

10 = DASL scrambler

11 = No scrambling

SCMOD2 Scrambler/ Descrambler indication mode (only valid in DELIC V2.3 and higher versions)

0 = No "scrambling finished" indication is provided
Descrambling is initiated following FSC rising edge

1 = "Scrambling finished" indication is provided by register SCSTA.
Descrambling is initiated by writing to register SCSTA

6.2.1.9 Scrambler Status Register

SCSTA Register

read/write

Address: D011_H

Reset value: undefined

15	14	13	12	11	10	9	8
x	x	x	x	x	x	x	x
7	6	5	4	3	2	1	0
x	x	x	x	x	x	SCSTA1	SCSTA0

SCSTA0 Descrambler Status

- 0 = Write access: start of descrambling algorithm for all channels enabled in the HRAM (**only valid if bit SCMOD2 = 1!**)
read access: descrambler is processing data
- 1 = Write access: start of scrambling algorithm for all channels enabled in the HRAM
read access: descrambling is finished

SCSTA1 Scrambler Status (**only valid if bit SCMOD2 = 1**)

- 0 = read access: scrambler is processing data
- 1 = read access: scrambling is finished

Note: Scrambling and descrambling will only work correctly if (in the initialization phase) bit 8 of the OAK register ST2 is set to '1' (See "GHDLUCU Frame Frequency" on page 213.)

6.2.2 IOMU Register Description

6.2.2.1 IOMU Control Register

ICR Register

read/write

Address: D040_H

Reset value: 02_H

15	14	13	12	11	10	9	8
x	x	x	x	x	x	x	x
7	6	5	4	3	2	1	0
x	x	ICDB	A	OD	DC	DR(1:0)	

ICDB Idle Current D-Buffer (for test purpose; only if IOMU is in idle mode: ICR:A = '0')

0 = Make frame buffer 0 accessible to the DSP

1 = Make frame buffer 1 accessible to the DSP

A IOMU Activation

0 = The IOMU is Idle. The state machine of the IOMU is idle, and no accesses to the I-buffer are executed by the IOMU.

1 = The IOMU is active, and works according to the programming of the other Control Register bits.

OD DD0 and DD1 Output Mode

0 = Push-Pull mode.

1 = Open-Drain mode

DC Double Data Rate Clock

0 = Single clock (DCL frequency is identical to the IOM-2 data rate)

1 = Double clock (DCL frequency is double the IOM-2 data rate)

DR(1:0) IOM-2 Data Rate

00 = IOM-2 data rate of 1 x 384 kbit/s (1 x 6 time slots/frame)

01 = IOM-2 data rate of 1 x 768 kbit/s (1 x 12 time slots/frame)

10 = IOM-2 data rate of 2 x 2.048 Mbit/s (2 x 32 time slots/frame)
(default)

11 = IOM-2 data rate of 1 x 4.096 Mbit/s (1 x 64 time slots/frame)

6.2.2.2 IOMU Status Register

ISR Register

read

Address: D041_H

Reset value: undefined

15	14	13	12	11	10	9	8
IBUFF	x	x	x	x	x	x	x
7	6	5	4	3	2	1	0
x	x	x	x	x	x	x	x

IBUFF I-Buffer Index

Note: Used for testing. May also be used in double data rate mode of the IOMU to determine if the IOMU buffers have been swapped already

0 = Buffer 0 is currently used as I-buffer, buffer 1 is used as D-buffer

1 = Buffer 1 is currently used as I-buffer, buffer 0 is used as D-buffer

Note: (x) unused bits read as '0'

6.2.2.3 IOMU Tri-State Control Register

ITSCR Register

read/write

Address:

Set Address:

D042_H

Reset Address:

D043_H

Read Address:

D044_H

Reset Value: 00_H

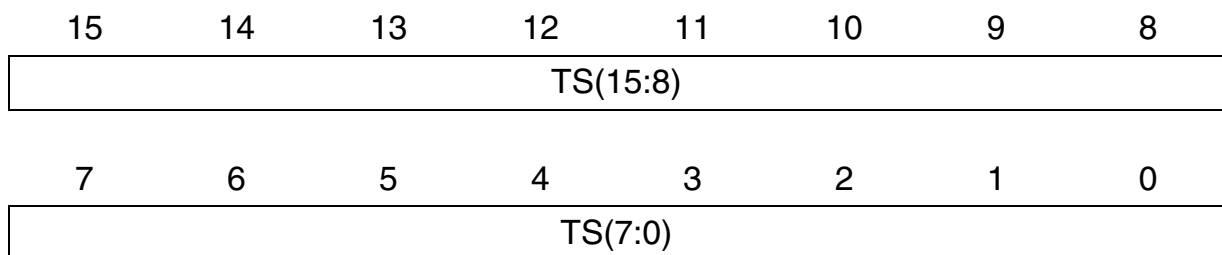

TS(15:0)

Every bit determines whether DD0/1 output is in tri-state during the time slot sequence. The time slot sequence length, indices and port controlled by each TS-bit is defined according the IOMU data rate mode (ICR.DR(1:0))

0 = DD0/1 is in tri-state during the related time slot sequence

1 = DD0/1 is driven by the IOMU during the related time slot sequence

Register Description

Table 62 Tristate Control Assignment for IOM-2 Time Slots

ITSCR Bit	1 x 6 TS/frame		1 x 12 TS/frame		2 x 32 TS/frame		1 x 64 TS/frame	
	DD0	TS	DD0	TS	DD0/1	TS	DD0/1	TS
TS0	DD0	0	DD0	0	DD0	0-3	DD0	0-3
TS1	DD0	1	DD0	1	DD0	4-7	DD0	4-7
TS2	DD0	2	DD0	2	DD0	8-11	DD0	8-11
TS3	DD0	3	DD0	3	DD0	12-15	DD0	12-15
TS4	DD0	4	DD0	4	DD0	16-19	DD0	16-19
TS5	DD0	5	DD0	5	DD0	20-23	DD0	20-23
TS6	not used		DD0	6	DD0	24-27	DD0	24-27
TS7	not used		DD0	7	DD0	28-31	DD0	28-31
TS8	not used		DD0	8	DD1	0-3	DD0	32-35
TS9	not used		DD0	9	DD1	4-7	DD0	36-39
TS10	not used		DD0	10	DD1	8-11	DD0	40-43
TS11	not used		DD0	11	DD1	12-15	DD0	44-47
TS12	not used		not used		DD1	16-19	DD0	48-51
TS13	not used		not used		DD1	20-23	DD0	52-55
TS14	not used		not used		DD1	24-27	DD0	56-59
TS15	not used		not used		DD1	28-31	DD0	60-63

6.2.2.4 IOMU DRDY Register

IDRDYR Register

read

Address: D045_H

Reset value: undefined

15	14	13	12	11	10	9	8
0	0	0	0	0	0	0	0
7	6	5	4	3	2	1	0
DS(7:0)							

bit DRDY Sample

DS_x indicates the availability of the D-channels of the previous frame.

0 = STOP (D-channel blocked due to collision), 1 = GO

e.g. DS₁ was sampled during the D-channel of IOM-2 channel 1, etc.

DS0	corresponds to D-channel of IOM-2 port 0 cha 0
DS1	corresponds to D-channel of IOM-2 port 0 cha 1
DS2	corresponds to D-channel of IOM-2 port 0 cha 2
DS3	corresponds to D-channel of IOM-2 port 0 cha 3
DS4	corresponds to D-channel of IOM-2 port 0 cha 4
DS5	corresponds to D-channel of IOM-2 port 0 cha 5
DS6	corresponds to D-channel of IOM-2 port 0 cha 6
DS7	corresponds to D-channel of IOM-2 port 0 cha 7

Note: In 1 x 4.096 Mbit/s mode (i.e. 16 IOM-2 channels/frame), DRDY is sampled only during the D-channels of the first eight IOM-2 channels of every frame.

6.2.2.5 IOMU Data Prefix Register

IDPR Register

read/write

Address: D046_H

Reset value: E0_H

15	14	13	12	11	10	9	8
IDP(7:0)							
7	6	5	4	3	2	1	0
x	x	x	x	x	x	x	x

IDP(7:0) IOMU Data Prefix

Determines the high byte of every word being read from the IOM circular-buffer (I-buffer or D-buffer). The low byte is the data being read from the circular buffer.

After reset this register contains the MSB of the base address of the A-law-to-linear ROM table: E0_H.

Note: (x) unused bits read as '0'

6.2.3 PCMU Register Description

6.2.3.1 PCMU Command Register

PCR Register

read/write

Address: D060_H

Reset value: 0000_H

15	14	13	12	11	10	9	8
x	x	x	x	x	x	x	x
7	6	5	4	3	2	1	0
x	x	SFH	ICDB	PA	PDCL	PDR(1:0)	

PDR(1:0) PCM Data Rate

- 00 = 2.048 Mbit/s (port 0..3)
- 01 = 4.096 Mbit/s (port 0, 2)
- 10 = 8.092 Mbit/s (port 0)
- 11 = 16.384 Mbit/s (1 x 256 time slots per frame, if only first or second half of 8 kHz frame is handled) (port 0)

PDCL PCM Double Data Rate Clock

- 0 = Single Data Rate Clock
- 1 = Double Data Rate Clock

PA PCMU Activation

- 0 = The PCMU is in idle mode
- 1 = The PCMU is in active mode

ICDB Idle Current D-Buffer

Used only for testing of PCMU in IDLE mode (PCR:PA = '0') to determine which buffer is being accessed by the DSP

- 0 = Frame buffer 0 is accessed by the DSP
- 1 = Frame buffer 1 is accessed by the DSP

SFH Second Frame Half

Applicable only in 16.384 Mbit/s data rate mode

- 0 = The first 128 time slots of each frame are handled by the PCMU
- 1 = The second 128 time slots of each frame are handled by the PCMU

Note: 'x' = unused (read as '0')

6.2.3.2 PCMU Status Register

PSR Register

read

Address: D061_H

Reset value: undefined

15	14	13	12	11	10	9	8
PBUFF	x	x	x	x	x	x	x
7	6	5	4	3	2	1	0
x	x	x	x	x	x	x	x

PBUFF P-Buffer Index

Note: Used for testing. May also be used in double data rate mode of the PCMU to determine if the PCMU buffers have been swapped already

0 = Buffer 0 is currently used as P-buffer, buffer 1 is used as D-buffer

1 = Buffer 1 is currently used as P-buffer, buffer 0 is used as D-buffer

Note: (x) unused bits read as '0'

Register Description

6.2.3.3 PCMU Tri-state Control Registers

PTSC0 Register	read/write (set/reset)	read Address: D062-63 _H set Address: D062H reset Address: D063H
PTSC1 Register	read/write (set/reset)	read Address: D064-65 _H set Address: D064 _H reset Address: D065H
PTSC2 Register	read/write (set/reset)	read Address: D066-67 _H set Address: D066 _H reset Address: D067 _H
PTSC3 Register	read/write (set/reset)	read Address: D068-69 _H set Address: D068 _H reset Address: D069 _H
PTSC4 Register	read/write (set/reset)	read Address: D06A-6B _H set Address: D06A _H reset Address: D06B _H

Register Description

PTSC5 Register	read/write (set/reset)	read Address: D06C-6D _H set Address: D06C _H reset Address: D06D _H
PTSC6 Register	read/write (set/reset)	read Address: D06E-6F _H set Address: D06E _H reset Address: D06F _H
PTSC7 Register	read/write (set/reset)	read Address: D070-71 _H set Address: D070 _H reset Address: D071 _H

Reset values (PTSC0..7): 0000_H

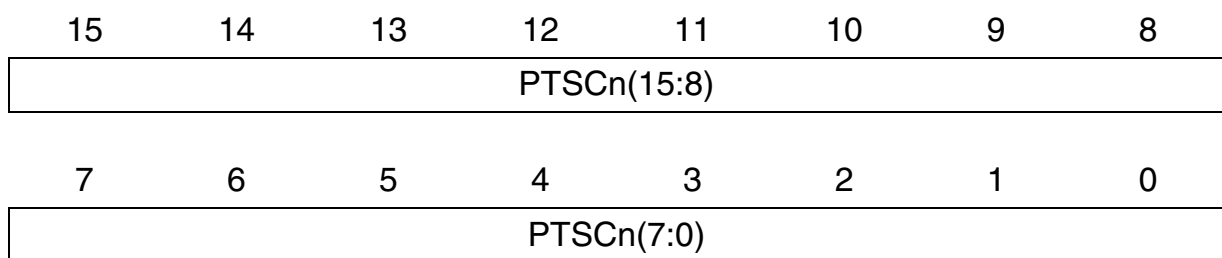

PTSCn (15..0) Tristate Control for each PCM Time Slot

0 = The controlled time slot is invalid

1 = The controlled time slot is valid

6.2.3.4 PCMU Data Prefix Register

P DPR Register

read/write

Address: D072_H

Reset value: E0_H

15	14	13	12	11	10	9	8
PDP(7:0)							
7	6	5	4	3	2	1	0
x	x	x	x	x	x	x	x

PDP(7:0) PCMU Data Prefix

The data written to this register is read as the most significant byte of every time slot read by the DSP from the PCMU frame buffers. Can be used for quick access to the a/μ-law ROM, for conversion of compressed data (received via the PCM interface) into linear value.

After reset this register contains the MSB of the base address of the a-law-to-linear ROM table: E0_H. To enable quick conversion from μ-law to linear, the PCMU Data Prefix Register should be programmed to E1_H.

Note: (x) unused bits read as '0'

6.2.4 A-/μ-law Unit Register Description

6.2.4.1 A/μ-law Unit Control Register

A/μ-law Unit Control Register (AMCR) read/write

Address: D020_H

Reset value: 0000_H

15	14	13	12	11	10	9	8
x	x	x	x	x	x	x	x
7	6	5	4	3	2	1	0
x	x	x	x	x	x	x	MODE

Note: 'x' = unused bits

This register controls the conversion mode of the A/μ-law unit

MODE	A/μ-law Mode Programming
0 =	Conversion from linear value to A-law value (default)
1 =	Conversion from linear value to μ-law value

6.2.4.2 A/ μ -law Input Register

A/ μ -law Unit Input Register (AMIR) write Address: D021_H

Reset value: undefined

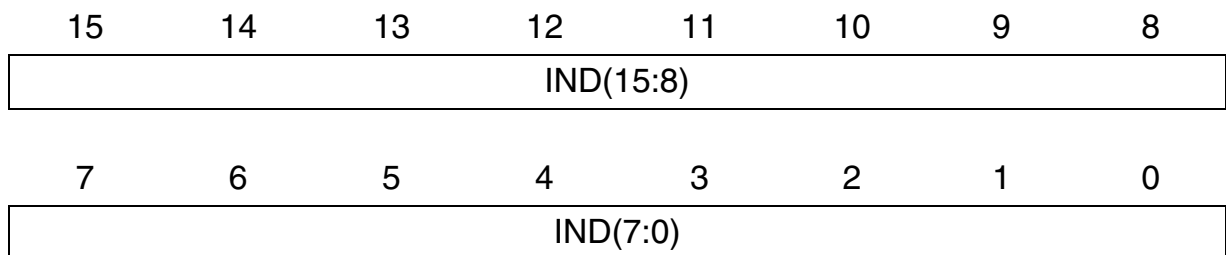

Note: - In μ -law mode, only the 14 MSBs are processed.
 - In A-law mode, only the 13 MSBs are processed.

IND(15:0) Linear Input Data
 Provides the linear input data that is to be converted into logarithmic data format according to A-law or μ -law algorithm.

6.2.4.3 A/ μ -law Output Register

A/ μ -law Unit Output Register (AMOR) read

Address: D022_H

Reset value: undefined

15	14	13	12	11	10	9	8
x	x	x	x	x	x	x	x
7	6	5	4	3	2	1	0
OUTD(7:0)							

Note: 'x' = unused bits, driven to '0'

OUTD(7:0) Logarithmic Output Data

Provides the logarithmic output data generated by the A/ μ -law unit out of the linear input data. The data format (A-law or μ -law) depends on the the selected conversion algorithm.

6.2.5 HDLCU Registers Description

6.2.5.1 HDLCU Control Register

In order to enable DSP access all the buffers and RAMS, DSPCTRL bit must be set to '1'.

HCR Register write Address: D180_H

Reset value: 0001_H

15	14	13	12	11	10	9	8
x	BITOR	x	x	x	x	x	x
7	6	5	4	3	2	1	0
x	HPRS(5:0)					DSPCTRL	

- BITOR** Determines the order of bits inside one HDLC data byte
 0 = HDLC data is transmitted/ received with MSB first (default)
 1 = HDLC data is transmitted/ received with LSB first
- HPRS(5:0)** HDLCU Channel Preset
 The number of HDLC channels to be processed by the HDLCU
- DSPCTRL** DSP Access Control to the HDLCU
 0 = The DSP must not access the HDLCU buffers and RAMs
 1 = The DSP may access the HDLCU buffers

Note: Each time DSPCTRL is set, HPRS is also set.

6.2.5.2 HDLCU Status Register

HSTA Register read Address: D180_H

Reset value: 0001_H

15	14	13	12	11	10	9	8
HHOLD	BITOR	x	CHCNT(5:1)				
7	6	5	4	3	2	1	0
CHCNT(0)		HPRS(5:0)					DSPCTRL

- DSPCTRL** DSP Access Control to the HDLCU
 0 = The HDLCU is currently processing the channel
 1 = The DSP is currently accessing the HDLCU
- HPRS(5:0)** HDLC Channel Preset
 Number of HDLC channels handled by the HDLCU (max. 32)
- CHCNT(5:0)** Channel Count
 Number of channels that have already been processed in the current frame
- BITOR** Bitorder
 Determines the order of bits inside an HDLC data byte going to (coming from) the IOMU, PCMU or TRANSIU.
 0 = HDLC data is transmitted with MSB first
 1 = HDLC data is transmitted with LSB first
- HHOLD** HDLCU Busy Indicator
 0 = HDLCU is processing the current frame
 1 = HDLCU has finished processing the current frame

6.2.5.3 Channel Command Vector

HCCV Registers read/ write Address: 4040_H - 405F_H

Each of the 32 HDLC channels has a 7-bit command vector that resides in the corresponding address of the command RAM. The structure of a command vector is as follows:

15	14	13	12	11	10	9	8
x	x	x	x	x	x	x	x
7	6	5	4	3	2	1	0
x	DBSEL	RECRES	TXCMD(2:0)			CRC	IDLE

*Note: Accesses to these registers are possible only if register bit HCR:DSPCTRL = 1
'x' = unused*

- DBSEL** D- or B-Channel Select
- 0 = Indication for a B-channel. HDLC protocol is performed on all 8 data bits
 - 1 = Indication for a D-channel. HDLC protocol is performed only on the 2 MSB data bit in the Receive Input Buffer and Transmit Output Buffer
- RECRES** Receiver Reset
- 0 = Normal operation
 - 1 = Reset the HDLC receiver
- TXCMD(2:0)** Transmit Command
- 000= End transmission
 - 001= Start transmission at the first bit of the D-channel
 - 010= Start transmission at the second bit of the D-channel
 - 011= Start transmitting a flag (beginning with the fifth bit of the flag, since '0111' is automatically inserted)
 - 100= Abort transmission
- Note: other combinations are reserved*
- CRC** CRC Enable
- 0 = CRC checking algorithm off

Register Description

IDLE	1 =	CRC checking algorithm on Inter Frame Timefill IDLE Mode
	0 =	Transmit 'ones' over an idle channel (no shared flag are possible in this mode)
	1 =	Transmit 'flags' over an idle channel (shared flags are supported)

Note: In the receive direction, the only function of the command vector is to indicate whether the channel is a D-channel or a B-channel, and whether to use CRC decoding or not.

The main function of the command vector is to control the flow of time slots in the transmit direction.

6.2.5.4 Channel Status Vector

HCSV Registers read Addresses: 40A0_H - 40BF_H

Reading a channel from the Receive Output Buffer and Writing to a channel in the Transmit Input Buffer is done according to the channel's status vector in the Transmit Output Buffer. This vector contains 7 flags:

15	14	13	12	11	10	9	8
x	x	x	x	x	x	x	x
7	6	5	4	3	2	1	0
x	FLAG	EMPTY	FULL	ABORT	STOP	CRC	NO

*Note: Accesses to these registers are possible only if register bit HCR:DSPCTRL = 1
'x' = not used*

NO	Not Octet 0 = Normal operation 1 = The last bits of a message have not filled an octet (8 bits)
CRC	CRC Error 0 = No CRC error in received message 1 = CRC error was detected in the received message
STOP	Stop Indication 0 = Normal operation 1 = HDLCU has detected an end of message flag in the receive direction. The DSP must read the octet in the Receive Output Buffer before the next message start flag is detected
ABORT	Abort Indication 0 = Normal operation 1 = The DSP has detected an incoming abort message (7 consecutive '1s'). The STOP flag is also set to 1. This means that the DSP should ignore the current message being transmitted over the channel in question and report to the external micro controller
FULL	Receive Buffer Full Indication

Register Description

- 0 = Normal operation
- 1 = Indicates that the Receive Output Buffer has a newly processed octet in it. The DSP must read this octet before starting the next processing session, otherwise it might be lost.

EMPTY Transmit Buffer Empty

- 0 = The transmit buffer is full.
- 1 = The transmit buffer is empty. The current time slot in the Transmit Input Buffer has been fully processed by the HDLCU. The Transmit Input buffer is ready to receive the next octet of the message by the DSP.

Note: The DSP must put a new octet into the buffer before starting the next processing session, otherwise the same octet will be read again.

FLAG Status Vector Flag

- 0 = Ignore the status vector and do not read or write on this channel
- 1 = Read the channel's status vector and process accordingly

Note: FLAG will go to '1' as soon as EMPTY or FULL go to '1'.

6.2.6 GHDLIC Register Description

6.2.6.1 GHDLIC Test/ Normal Mode Register

GTEST Register read/write Address: D0C0_H

Reset value: 0001_H

15	14	13	12	11	10	9	8
x	x	x	x	x	x	x	x
7	6	5	4	3	2	1	0
x	x	x	x	x	x	x	TEST

CHMOD1..0 Channel Mode

0 = Normal operation mode

1 = Test mode

Note: As GTEST has a reset value of 01H this register has to set to 0 to enable the GHDLICU

6.2.6.2 GHDLC Channel Mode Register

GCHM Register

read/write

Address: D0C1_H

Reset value: 0000_H

15	14	13	12	11	10	9	8
x	x	x	x	x	x	x	x
7	6	5	4	3	2	1	0
x	x	x	x	x	x	CHMOD(1..0)	

CHMOD1..0 Channel Mode

- 00 = Channel 0 used for up to 8.192 MHz (DELIC-PB only)
Channel 0 used for up to 2.048 MHz (DELIC-LC)
GHDLC buffer size = 32 bytes
- 01 = 2 channels (ch 0+3) used for up to 2.048 MHz
GHDLC buffer size = 2 x 16 bytes
Note: DELIC-PB only
- 10 = 4 channels (ch 0..3) used up to 2.048 MHz
GHDLC buffer size = 4 x 8 bytes
Note: DELIC-PB only
- 11 = Reserved

6.2.6.3 GHDLC Interrupt Register

GINT Register

read

Address: D0D4_H

Reset value: 0000_H

15	14	13	12	11	10	9	8
x	x	x	x	x	x	x	x
7	6	5	4	3	2	1	0
x	x	x	x	INT3	INT2	INT1	INT0

INT_n bits Interrupt Indication for GHDLC Channel n (= 0..3)

0 = Normal operation

1 = GHDLC interrupt has occurred

Note: INT0-INT3 are reset by a read access to this register

Note: For GCHM:CHMOD = 00 (cha. 0 up to 8 MBit/s) only INT0 is used

For GCHM:CHMOD = 01 (cha. 0 and 3 up to 2 MBit/s) only INT0, INT3 are used.

For GCHM:CHMOD = 10 (cha. 0..3 up to 2 MBit/s) all bits are used

6.2.6.4 GHDLC FSC Interrupt Control Register

GFINT Register

read

Address: D0D3_H

Reset value: 0000_H

15	14	13	12	11	10	9	8
x	x	x	x	x	x	x	x
7	6	5	4	3	2	1	0
x	x	x	x	FINT3	FINT2	FINT1	FINT0

FINT_n FSC Interrupt Control GHDLC Channel n (= 0..3)

0 = The rising edge of a 62.5 μs/ 10μs frame causes a receiver interrupt only if a full interrupt has not occurred during the previous frame

1 = The rising edge of a 62.5 μs/ 10μs frame causes a receiver interrupt regardless whether or not a full interrupt occurred during the previous frame

Note: The interrupt frequency can be set in register ST2 ([Chapter 6.2.6.15](#)).

6.2.6.5 GHDLC Receive Channel Status Registers 0..3

GRSTA Register 0	read	Address: D0C2 _H
GRSTA Register 1	read	Address: D0C3 _H
GRSTA Register 2	read	Address: D0C4 _H
GRSTA Register 3	read	Address: D0C5 _H

Reset value: 001F_H

15	14	13	12	11	10	9	8
x	x	x	x	x	x	COLLD	UNDER
7	6	5	4	3	2	1	0
EMPTY	OVER	FULL	RBFILL(4:0)				

- RBFILL(4:0)** Receive Buffer Fill
Indicates to the DSP the currently available number of bytes - 1 in the receive buffer
- FULL** Receive Buffer Full
0 = No receive buffer full indication
1 = Receive buffer block of the GHDLC is full. The blocks have been switched.
- OVER** Buffer Overrun
0 = No buffer overrun indication
1 = Two consecutive full interrupts were received without a GHDLC access to the status register in between, i.e. a buffer was missed.
- EMPTY** Transmit Buffer Empty
0 = No transmit buffer empty indication
1 = The transmit buffer block currently being transmitted over the GHDLC channel has been emptied
- UNDER** Buffer Underrun
0 = No buffer underrun indication
1 = A buffer containing an incomplete message has been emptied without a continuation of the message in the other buffer

Register Description

- COLLD** Collision Detected
- 0 = No collision detection indication
 - 1 = Collision detected during transmission. The message needs to be re-sent.
- Note: Only relevant in HDLC-Mode, if one device does not operate conform to the HDLC protocol definition*

Note: Reading the register GRSTA resets its bits to the default value.

6.2.6.6 GHDLIC Receive Data and Status

To each data byte in the receive buffer 4 flag bits are appended

RXDAT Registers read Address: 2040_H -207F_H

15	14	13	12	11	10	9	8
ABORT	END	CRC	NO	x	x	x	x
7	6	5	4	3	2	1	0
RDAT7..0							

- NO** Not Octet
 0 = Received message is a multiple of eight bits
 1 = Received message is not a multiple of eight bits
- CRC** CRC Error Flag
 0 = Received byte contains no CRC error flag.
 1 = Received byte contains a CRC error flag.
 A CRC error was detected in the received frame.
- END** END Flag
 0 = Received byte contains no END flag
 1 = Received byte contains an END flag
- ABORT** ABORT Flag
 0 = Received byte contains no ABORT flag
 1 = Received byte contains an ABORT flag
- RD7..0** Received data byte

6.2.6.7 GHDLC Mode Registers

GMOD Register 0	read/write	Address: D0C6 _H
GMOD Register 1	read/write	Address: D0C7 _H
GMOD Register 2	read/write	Address: D0C8 _H
GMOD Register 3	read/write	Address: D0C9 _H

Reset value: 0140_H

15	14	13	12	11	10	9	8
x	x	x	x	GEM	GEDGE	EDGE	TE
7	6	5	4	3	2	1	0
CLASS	COLLD	PPOD	IFTF	OPMOD(1:0)		CRCMOD(1:0)	

CRCMOD (1:0) CRC Mode

- 00 = CRC algorithm disabled
- 01 = 16-bit CRC algorithm ($X^{16}+X^{12}+X^5+1$)
- 10 = 32-bit CRC algorithm
($X^{31}+X^{26}+X^{23}+X^{22}+X^{16}+X^{12}+X^{11}+X^{10}+X^8+X^7+X^5+X^4+X^2+X^1+1$)
- 11 = reserved

OPMOD(1:0) Operational Mode
Programs the mode of the GHDLC channel

Note: Every channel of GHDLC, that is not in use, should be programmed to Async mode (OPMOD = "10"), in order to prevent any access of the idled channels to the GHDLC buffers. For example, if GHDLC channel mode register CHMOD = "00" (operation only of channel 0) then OPMOD field in registers GMOD 1/2/3 should be set to "10" (Async mode)

- 00 = HDLC mode
- 01 = Extended transparent mode
- 10 = Asynchronous mode (enables accesses to register GASYNC)
- 11 = reserved

IFTF Interframe Time Fill

- 0 = Sequence of '1s' is used as interframe time fill characters

Register Description

	1 =	Flags (7E _H) are used as interframe time fill characters
PPOD		Push-Pull / Open-Drain Configuration
	0 =	Open-drain
	1 =	Push-pull
COLLD		Collision Detection
	0 =	Collision detection disabled
	1 =	Arbitration between several GHDLC on a bus is done using collision detection
CLASS		Priority Class Assignment
	0 =	Channel has priority class 8
	1 =	Channel has priority class 10
TE		Transmit Enable
	0 =	Transmit line is only enabled during the transmission of a message including opening and closing flags
	1 =	Transmit line is always enabled
EDGE		Edge Programming for Receive Data Sampling
	0 =	Receiver samples data on rising edge of the line clock
	1 =	Receiver samples data on falling edge of the line clock
GEDGE		Edge Programming for GHDLC Receive Data Sampling
	0 =	Receiver samples data on rising edge of the line clock
	1 =	Receiver samples data on falling edge of the line clock
GEM		GHDLC Enhanced Mode
	0 =	Normal Operation GEDGE is disabled, EDGE is used for sampling the data.
	1 =	Enhanced Operation GEDGE is enabled, EDGE has to be programmed to the opposite of GEDGE.

Note: The enhanced mode ensures proper handling of Interframe time fill (ITF) flags with shared '0' (please refer to [Figure 50](#)). In enhanced operation an additional delay of 15 μs is added to the received data.

6.2.6.8 GHDLC Channel Transmit Command Registers

GTCMD Register 0	write	Address: D0CA _H
GTCMD Register 1	write	Address: D0CC _H
GTCMD Register 2	write	Address: D0CE _H
GTCMD Register 3	write	Address: D0D0 _H

Reset value: 0000_H

15	14	13	12	11	10	9	8
x	x	x	x	x	x	x	x
7	6	5	4	3	2	1	0
x	STOP	TXCMD	TBFILL(4:0)				

- TBFILL(4:0)** Transmit Buffer Fill
Indicates to the GHDLC unit the currently available number of bytes - 1 in the transmit buffer.
- TXCMD** Transmission Command
0 = Transmission is not started
1 = Start transmission
- STOP** Stop Command
0 = Message continues in the next buffer
1 = End of the message is in this buffer

6.2.6.9 ASYNC Control Register

GASYNC Register

read/ write

Address: D0D2_H

Reset value: 0000

15	14	13	12	11	10	9	8
x	x	x	x	x	x	x	x
7	6	5	4	3	2	1	0
IOPORT(7..0)							

Accesses to register GASYNC:

IOPORT bits	Writing a "1" to the bit position sets the port pin below	Reading from the bit position indicates the current state of the port pin below
bit 0	LTXD0	LRXD0
bit 1	LTXD1	LRXD1
bit 2	LTXD2	LRXD2
bit 3	LTXD3	LRXD3
bit 4	LRTS0	LCTS0
bit 5	LRTS1	LCTS1
bit 6	LRTS2	LCTS2
bit 7	LRTS3	LCTS3

Accesses to the different bits of this register are only possible in ASYNC mode of the corresponding GHDLC channel (See "GHDLC Mode Registers" on page 204.).

Note: GHDLC channels 3,2,1 are only accessible, if the respective bits in register MUXCTRL are set.

6.2.6.10 LCLK0 Control Register

LCLK0 Control Register (GLCLK0) read/write

Address: D08A_H

Reset value: 0000_H

15	14	13	12	11	10	9	8
x	x	x	x	x	x	x	x
7	6	5	4	3	2	1	0
x	x	x	x	x	LCLK0EN	LCLK0(1:0)	

Note: 'x' = unused bits, read as 0

LCLK0EN LCLK0 Output Enable

0 = LCLK0 is input (default)

1 = LCLK0 is driven outward via LCLK0 pin

LCLK0(1:0) LCLK0 Output Clock Rate

Note: This option is valid only when LCLK0 is output. When LCLK0 is input the frequency is determined externally.

00 = 2.048 MHz (default)

01 = 4.096 MHz

10 = 8.192 MHz

11 = 16.384 MHz

6.2.6.11 LCLK1 Control Register

LCLK1 Control Register (GLCLK1) read/write

Address: D08B_H

Reset value: 0000_H

15	14	13	12	11	10	9	8
x	x	x	x	x	x	x	x
7	6	5	4	3	2	1	0
x	x	x	x	x	LCLK1EN	LCLK1(1:0)	

Note: 'x' = unused bits, read as 0

LCLK1EN LCLK1 Output Enable

0 = LCLK1 is input (default)

1 = LCLK1 is driven outward via LCLK1 pin

LCLK1(1:0) LCLK1 Output Clock Rate

Note: This option is valid only when LCLK1 is output. When LCLK1 is input the frequency is determined externally.

00 = 2.048 MHz (default)

01 = 4.096 MHz

10 = 8.192 MHz

11 = 16.384 MHz

6.2.6.12 LCLK2 Control Register

LCLK2 Control Register (GLCLK2) read/write

Address: D08C_H

Reset value: 0000_H

15	14	13	12	11	10	9	8
x	x	x	x	x	x	x	x
7	6	5	4	3	2	1	0
x	x	x	x	x	LCLK2EN	LCLK2(1:0)	

Note: 'x' = unused bits, read as 0

LCLK2EN LCLK2 Output Enable

0 = LCLK2 is input (default)

1 = LCLK2 is driven outward via LCLK2 pin

LCLK2(1:0) LCLK2 Output Clock Rate

Note: This option is valid only when LCLK2 is output. When LCLK2 is input the frequency is determined externally.

00 = 2.048 MHz (default)

01 = 4.096 MHz

10 = 8.192 MHz

11 = 16.384 MHz

6.2.6.13 LCLK3 Control Register

LCLK3 Control Register (GLCLK3) read/write

Address: D08D_H

Reset value: 0000_H

15	14	13	12	11	10	9	8
x	x	x	x	x	x	x	x
7	6	5	4	3	2	1	0
x	x	x	x	x	LCLK3EN	LCLK3(1:0)	

Note: 'x' = unused bits, read as 0

LCLK3EN LCLK3 Output Enable

0 = LCLK3 is input (default)

1 = LCLK3 is driven outward via LCLK3 pin

LCLK3(1:0) LCLK3 Output Clock Rate

Note: This option is valid only when LCLK3 is output. When LCLK3 is input the frequency is determined externally.

00 = 2.048 MHz (default)

01 = 4.096 MHz

10 = 8.192 MHz

11 = 16.384 MHz

6.2.6.14 Muxes Control Register

MUXCTRL Register

OAK: read/write

Address: D14A_H

Reset value: 0000_H

15	14	13	12	11	10	9	8
x	x	x	x	x	x	x	x
7	6	5	4	3	2	1	0
x	x	x	x	x	PMUX1	PMUX0	IMUX

IMUX

- 0 = IOM-2000 pins are used for the IOM-2000 interface
- 1 = IOM-2000 pins are used for the GHDLC cha. 1

PMUX0

- 0 = PCM ports 0 & 2 pins are used for PCM
- 1 = PCM ports 0 & 2 pins are used for GHDLC cha. 2

PMUX1

- 0 = PCM ports 1 & 3 pins are used for PCM
- 1 = PCM ports 1 & 3 pins are used for GHDLC cha. 3

6.2.6.15 GHDLCU Frame Frequency

ST2 Register

OAK: write

Address: DSP-register

Reset value: xxxx xx00 xxxx xxxx_B

15	14	13	12	11	10	9	8
x	x	x	x	x	x	OUSER1	OUSER0
7	6	5	4	3	2	1	0
x	x	x	x	x	x	x	x

OUSER1

- 0 = 16 kHz GHDLCU frame frequency
- 1 = 96 kHz GHDLCU frame frequency

OUSER0

- 0 = Test mode
write access to HRAM-0 is enabled
write access to HRAM-1, HRAM-2 is disabled
- 1 = write access to HRAM0, HRAM-1, HRAM-2 is enabled¹⁾

¹⁾ This bit has to be set once during initialization for single scrambling mode. If mixed scrambling mode is used (e.g. DASL/OCTAT-P) the following has to be done: When accessing the HRAM this bit has to be reset ('0') before enabling descrambler/scrambler it has to be set ('1').

6.2.7 DCU Register Description

6.2.7.1 Interrupt Mask Register

IMASK Register

read/write

Address: D002_H

Reset value: 0000_H

15	14	13	12	11	10	9	8
x	x	x	x	x	x	x	x
7	6	5	4	3	2	1	0
x	x	x	x	x	x	x	IMASK

IMASK GHDLC Interrupt Mask

0 = GHDLC interrupt disabled

1 = GHDLC interrupt enabled

Note: The unused bits (x) are read as '0'.

6.2.7.2 Status Event Register

STEVE Register

read

Address: D003_H

Reset value: 0000_H

15	14	13	12	11	10	9	8
x	x	x	x	x	x	x	x
7	6	5	4	3	2	1	0
x	x	x	x	x	PFS	FSC	FP

PFS

PFS Status Bit

0 = normal operation

1 = PFS rising edge has occurred (reset by DSP read access)

FSC

FSC Status Bit

0 = normal operation

1 = FSC rising edge has occurred (reset by DSP read access)

FP

FSC & PFS Status Bit

0 = normal operation

1 = Both FSC and PFS rising edges have occurred, i.e. bits PFS and FSC are set (reset by DSP read access)

Note: Unused bits ('x') are read as '0'.

6.2.7.3 Statistics Counter Register

STATC Register

read/write

Address: D004_H

Reset value: unchanged

Reset value: unchanged upon chip reset, but reset upon FSC detection if STATC was read by the DSP since last occurrence of FSC.

15	14	13	12	11	10	9	8
x	x	x	x	x	x	x	x
7	6	5	4	3	2	1	0
STATC(7:0)							

STATC Statistics Counter Value
(7:0)

Note: The unused bits (x) are read as '0'.

6.2.7.4 Statistics Register

STATI Register

read/write

Address: D005_H

Reset value: 0000_H

15	14	13	12	11	10	9	8
x	x	x	x	x	x	x	x
7	6	5	4	3	2	1	0
MSC(7:0)							

MSC(7:0) Max. Statistics Count

Note: The unused bits (x) are read as '0'.

6.2.8 μ P Configuration Registers

6.2.8.1 μ P Interface Configuration Register

MCFG Register
D148_H

DSP: read

DSP Address:

μ P: read/write

μ P high address: none
 μ P low address: 48_H

Reset value: 00_H

15	14	13	12	11	10	9	8
x	x	x	x	x	x	x	MODE
7	6	5	4	3	2	1	0
DRQLV	IRQLV	IRQMO	IMASK	IACK	PEC	FB	DMA

DMA DMA Mode Enabled

0 = No DMA

1 = DMA enabled

FB Fly-by Mode

0 = Memory-to-memory mode used for DMA transfers

1 = Fly-by mode used for DMA transfers

PEC PEC Transfers Enable

0 = No PEC Transfers

1 = PEC transfers are supported (for connection of C16x μ P)

IACK Interrupt Acknowledge Mode

0 = Interrupt vector is provided to CPU after 1st IACK pulse.

1 = Interrupt vector is provided to CPU after 2nd IACK pulse.

IMASK Interrupt Mask

0 = IREQ pin is disabled

1 = IREQ pin is enabled

IRQMO IREQ Pin Mode

0 = Open-drain mode

Register Description

	1 =	Push-pull mode
IRQLV		IREQ Pin Level
	0 =	Low active
	1 =	High active
DRQLV		DREQR/DREQT Pins Level
	0 =	High active
	1 =	Low active
MODE		μ P Interface Mode
		Contains the value of MODE input pin sampled by rising edge of $\overline{\text{RESET}}$
		<i>Note: This signal is hardwired.</i>
	0 =	Intel/Siemens mode
	1 =	Motorola mode

6.2.8.2 Interrupt Vector Register

IVEC Register
D168_H

DSP: read/ write

DSP Address:

μP: read

μP high address: none
μP low address: 68_H

Reset value: unchanged

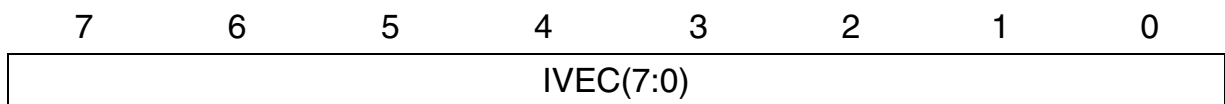

IVEC7..0 Interrupt vector
Contains the interrupt vector address that is output during an INTA cycle of the μP

6.2.9 μ P Mailbox Registers Description

6.2.9.1 μ P Command Register

MCMD Register

D140_H

DSP: read

DSP address:

μ P: write

μ P address: 40_H

Reset value: 00_H



MCMD μ P Command

Contains the μ P command (8-bit opcode) to the DELIC.

6.2.9.2 μ P Mailbox Busy Register

MBUSY Register
D141_H

DSP: write

DSP Address:

μ P: read

μ P high address: 41_H

μ P low address: none

Reset value: 00_H

15	14	13	12	11	10	9	8
MBUSY	x	x	x	x	x	x	x
7	6	5	4	3	2	1	0
x	x	x	x	x	x	x	x

MBUSY μ P Mailbox Busy Bit

0 = Mailbox is available for the external μ P. The μ P may write a command to MCMD.

1 = Mailbox is blocked for the external μ P. The μ P may not write a command to MCMD.

Note: MBUSY is automatically set each time a command is written to MCMD by the μ P.

MBUSY is reset automatically by a direct OAK write operation to the MBUSY register.

Register Description

6.2.9.3 μ P Mailbox Generic Data Register

MGEN Register
D144_H

DSP: read

DSP Address:

DSP high: D143_H

DSP low: D142_H

μ P: write

μ P high: 43_H

μ P low: 42_H

Reset value: unchanged

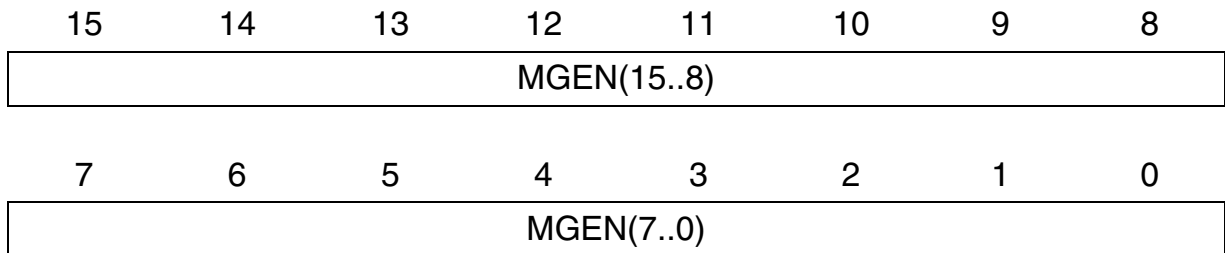

MGEN μ P Mailbox Generic Data (16 bits)
(15..0)

6.2.9.4 μ P Mailbox (General and DMA Mailbox) Data Registers

MDTn Register (n=0..7) DSP: read Addr. see table
on [page 156](#)

TDTn/ MDTn+8 Register (n=0..7) μ P: write

Reset value: unchanged

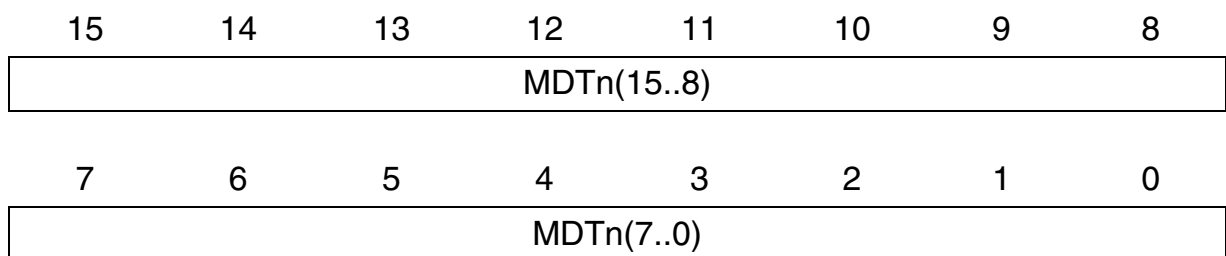

MDTn (15..0) μ P Mailbox Data (each byte is addressed separately by the external μ P)

Note: The 16 data registers (MDT1..7, TDT0/MDT8..TDT7/MDT15) have the same structure. The addresses are displayed in the register map ([page 156](#), [page 158](#)).

Register Description

6.2.9.5 DSP Command Register

OCMD Register
D160_H

DSP: write

DSP address:

μP: read

μP address: 60_H

Reset value: 00_H

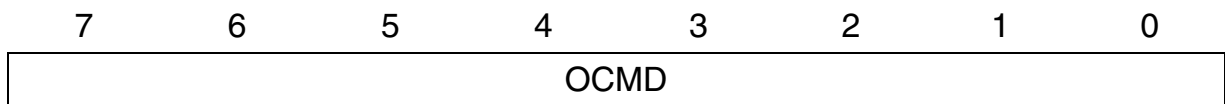

OCMD DSP Command

Contains the DSP command/ indication (8-bit opcode) to the DELIC.

Register Description

6.2.9.6 DSP Mailbox Busy Register

OBUSY Register
D161_H

DSP: read

DSP Address:

μP: read/ write

μP high address: 61_H

μP low address: none

Reset value: 00_H

15	14	13	12	11	10	9	8
OBUSY	x	x	x	x	x	x	x
7	6	5	4	3	2	1	0
x	x	x	x	x	x	x	x

OBUSY DSP Mailbox Busy Bit

0 = Mailbox is available for the DSP. The DSP may write a command/ indication OCMD.

1 = Mailbox is blocked for the DSP. The DSP may not write a command/ indication to OCMD.

Note: OBUSY is automatically set each time a command/ indication is written to OCMD by the DSP.

OBUSY is reset automatically by a direct μP write operation to the OBUSY register

Register Description

6.2.9.7 DSP Mailbox Generic Data Register

OGEN Register
D164_H

DSP: write

DSP address:

DSP high: D163_H

DSP low: D162_H

μP: read

μP high: 63_H

μP low: 62_H

Reset value: unchanged

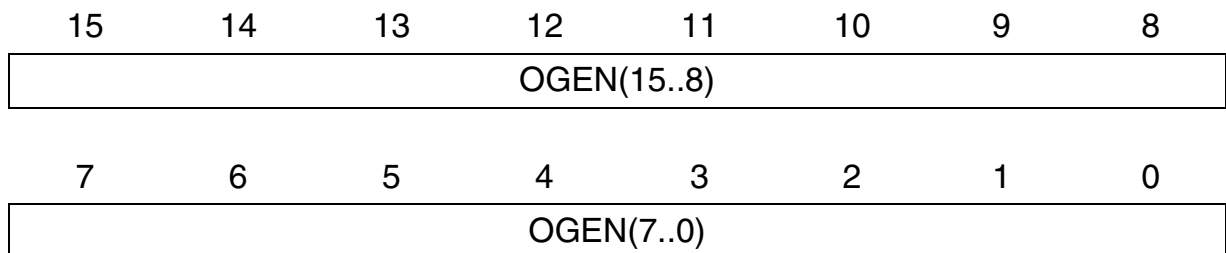

OGEN DSP Mailbox Generic Data (16 bits)
15..0

6.2.9.8 DSP Mailbox (General and DMA Mailbox) Data Registers

ODTn Register (n= 0..15)	DSP: write	Addr. on page 158
RDTn/ ODTn+8 Register (n=0..7)	μP: read	

Reset value: unchanged

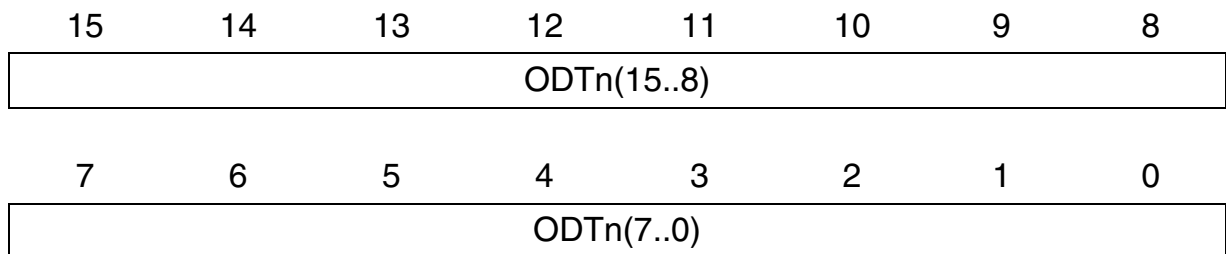

ODTn (15..0) DSP Mailbox Data (each byte is addressed separately by the external μP)

Note: The 16 data registers (ODT1..7, RDT0/ODT8..RDT7/ODT15) have the same structure. The addresses are displayed in the register map ([page 156](#), [page 158](#)).

6.2.10 DMA Mailbox Registers Description

6.2.10.1 DMA Mailbox Transmit Counter Register

DTXCNT Register

DSP: read/write

Address: D150_H

Reset value: 000F_H

15	14	13	12	11	10	9	8
x	x	x	x	x	x	x	x
7	6	5	4	3	2	1	0
x	x	x	x	TXCNT(3:0)			

Note: Writing to TXCNT initiates a DMA transfer of TXCNT+1 bytes to the DMA Tx Mailbox. TXCNT is decremented with every DMA cycle. When all bytes have been transmitted TXCNT has the value 'F'.

TXCNT(3..0) Number of bytes to be transmitted minus 1

6.2.10.2 DMA Mailbox Receive Counter Register

DRXCNT Register

DSP: read/write

Address: D170_H

Reset value: 000F_H

15	14	13	12	11	10	9	8
x	x	x	x	x	x	x	x
7	6	5	4	3	2	1	0
x	x	x	x	RXCNT(3:0)			

Note: Writing to RXCNT initiates a DMA transfer of RXCNT+1 bytes to the DMA Rx Mailbox. RXCNT is decremented with every DMA cycle. When all bytes have been transmitted RXCNT has the value 'F'.

RXCNT(3..0) Number of bytes to be received minus 1

6.2.10.3 DMA Mailbox Interrupt Status Register

DINSTA Register

DSP: read/ write

Address: D152_H

Reset value: 0000_H

15	14	13	12	11	10	9	8
x	x	x	x	x	x	x	x
7	6	5	4	3	2	1	0
x	x	x	x	TINT	RINT	TMSK	RMSK

Contains the status of the DMA Mailbox. The bits in this register are reset by a read access to register DINSTA.

TINT Transmit Interrupt from DMA Mailbox (**Read only**)

0 = No transmit interrupt from DMA-mailbox occurred

1 = The DMA-controller has finished to write the requested number of bytes to the DMA-mailbox.

RINT Receive Interrupt from DMA Mailbox (**Read only**)

0 = No transmit interrupt from DMA-mailbox occurred

1 = The DMA-controller has finished to read the requested number of bytes from the DMA-mailbox.

TMSK Transmit Interrupt Mask (**Read/ Write**)

0 = Disable transmit interrupt

1 = Enable transmit interrupt

RMSK Receive Interrupt Mask (**Read/ Write**)

0 = Disable receive interrupt

1 = Enable receive interrupt

6.2.11 Clock Generator Register Description

6.2.11.1 PDC Control Register

PDC Control Register (CPDC) read/write Address: D080_H

Reset value: 0000_H

15	14	13	12	11	10	9	8
x	x	x	x	x	x	x	x
7	6	5	4	3	2	1	0
x	x	x	x	x	x	PDC(1:0)	

Note: 'x' = unused bits, read as 0

PDC(1:0) PDC Frequency Selection (Only in Master Mode when PDC is output)

- 00 = PDC = 2.048 MHz (default)
- 01 = PDC = 4.096 MHz
- 10 = PDC = 8.192 MHz
- 11 = PDC = 16.384 MHz

6.2.11.2 PFS Control Register

PFS Control Register (CPFS)

read/write

Address: D081_H

Reset value: 0001_H

15	14	13	12	11	10	9	8
x	x	x	x	x	x	x	x
7	6	5	4	3	2	1	0
x	x	x	x	x	x	x	PFS

Note: 'x' = unused bits, read as 0

- PFS** PFS Frequency Selection
(Selectable in Slave mode when PFS is input; in Master mode PFS = 8 kHz)
- 0 = PFS = 4 kHz
 - 1 = PFS = 8 kHz (default)

*Note: When the PFS is output, its frequency is always 8 kHz, therefore this bit should be left in its reset-value ('1') and not to be changed.
The direction of PFS and PDC: input (slave) or output (master) is determined by the Master/Slave strap (DREQR pin) during reset.*

6.2.11.3 CLKOUT Control Register

CLKOUT Control Register (CLKOUT) read/write

Address: D082_H

Reset value: 0008_H

15	14	13	12	11	10	9	8
x	x	x	x	x	x	x	x
7	6	5	4	3	2	1	0
x	x	x	x	CLKOUTEN	CLKOUT		

Note: 'x' = unused bits, read as 0

CLKOUTEN CLKOUT Pin Enable

0 = CLKOUT pin is in tri-state.

1 = CLKOUT pin is active. (default)

CLKOUT CLKOUT Pin Frequency

000 = 2.048 MHz

001 = 4.096 MHz (default)

010 = 8.192 MHz

011 = 15.36 MHz

100 = 16.384 MHz

6.2.11.4 DCXO Reference Clock Select Register

REFSEL Register (CREFSEL)

read/write

Address: D083_H

Reset value: 0000_H

15	14	13	12	11	10	9	8
x	x	x	x	x	x	x	x
7	6	5	4	3	2	1	0
x	x	x	x	REFSEL EN	REFSEL(2:0)		

Note: 'x' = unused bits, read as 0

This register controls the selection of the source of the DCXO 8kHz reference clock

REFSELEN DCXO Reference Clock Enable

0 = The reference clock is disabled (default)

1 = The reference clock is enabled

REFSEL(2:0) DCXO Reference Clock Select

000 = DXCLK/192 (default)

001 = XCLK/256

010 = XCLK

011 = REFCLK (when input)

100 = REFCLK (when input)/64

101 = PFS (when input)

6.2.11.5 REFCLK Control Register

REFCLK Control Register (CREFCLK) read/write

Address: D084_H

Reset value: 0003_H

15	14	13	12	11	10	9	8
x	x	x	x	x	x	x	x
7	6	5	4	3	2	1	0
x	x	x	x	REFCLKEN	REFDIV(2:0)		

Note: 'x' = unused bits, read as 0.

REFCLK may be configured as an input or as an output. When configured as an input, it may be used as a source for the on-chip DCXO 8kHz reference clock. This option is handled by the DCXO Reference Clock Select Register (CREFSEL).

When configured as an output it is derived from XCLK input pin. In order to drive REFCLK, XCLK may be divided by 256, 192, 4, 3 or 1.

REFCLKEN REFCLK Pin Output Enable
 0 = REFCLK is input, the pad is not output enabled
 1 = REFCLK is output

REFDIV(2:0) REFCLK Pin Output Divider Selection
 This determines the value by which the XCLK maximum clock of 2.048 MHz is divided internally.
 000 = Division by 256
 001 = Division by 192
 010 = Division by 4
 011 = Division by 3 (default)
 100 = Division by 1

6.2.11.6 DCL_2000 Control Register

DCL_2000 Control Register (CDCL2) read/write

Address: D085_H

Reset value: 0004_H

15	14	13	12	11	10	9	8
x	x	x	x	x	x	x	x
7	6	5	4	3	2	1	0
x	x	x	x	x	DCL2EN	DCL2(1:0)	

Note: 'x' = unused bits, read as 0

DLC2EN DCL_2000 Clock Enable

0 = DCL_2000 clock is disabled

1 = DCL_2000 clock is enabled (default)

DCL2(1:0) DCL_2000 Clock Rate

00 = 3.072 MHz (default)

01 = 6.144 MHz

10 = 12.288 MHz

6.2.11.7 DCL Control Register

DCL Control Register (CDCL)

read/write

Address: D086_H

Reset value: 000B_H

15	14	13	12	11	10	9	8
x	x	x	x	x	x	x	x
7	6	5	4	3	2	1	0
x	x	x	x	DCLEN	DCL(2:0)		

Note: 'x' = unused bits, read as 0

DCLEN DCL Clock Enable

0 = DCL is disabled

1 = DCL is enabled (default)

DCL(2:0) DCL Clock Rate

000 = 384 kHz

001 = 768 kHz

010 = 1536 kHz

011 = 2048 kHz (default)

100 = 4096 kHz

6.2.11.8 FSC Control Register

FSC Control Register (2)

read/write

Address: D087_H

Reset value: 0002_H

15	14	13	12	11	10	9	8
x	x	x	x	x	x	x	x
7	6	5	4	3	2	1	0
x	x	x	x	IFSCD	EFSCD	FSCEN	FSCSH

Note: 'x' = unused bits, read as 0

FSCEN FSC Clock Enable

0 = FSC is disabled (stuck at '0')

1 = FSC is enabled (**default**)

FSCSH Short FSC Pulse

0 = The next FSC pulse will be longer than 2 DCL cycles (**default**)

1 = The next FSC pulse will be shorter than 2 DCL cycles (short FSC)

EFSCD External FSC Delay

0 = no delay between FSC and DCL rising edge (**recommended for VIP V2.1 and higher**)

1 = FSC rising edge is delayed by one CLK61 clock (16 ns) relative to DCL/ DCL2000 (**suitable only for VIP up to V1.1**)

IFSCD Internal FSC Delay (**only valid if CSTRAP: bit0 = 1**)

0 = no delay between FSC and DCL rising edge (**default**)

1 = FSC rising edge is delayed by one CLK61 clock (16 ns) relative to DCL/ DCL2000 (**only for test purpose**)

Note: If only one short FSC pulse is needed, this bit should be reset to '0' by the DELIC software, after the next FSC rising edge detection (after the beginning of the next frame). It is not executed automatically by the hardware.

6.2.11.9 L1_CLK Control Register

L1_CLK Control Register (CL1CLK) read/write

Address: D088_H

Reset value: 0000_H

15	14	13	12	11	10	9	8
x	x	x	x	x	x	x	x
7	6	5	4	3	2	1	0
x	x	x	x	x	x	L1CLKDIS	L1CLK

Note: 'x' = unused bits, read as 0

L1CLKEN L1_CLK Disable

0 = L1_CLK is enabled (default)

1 = L1_CLK is disabled

L1CLK L1_CLK Clock Rate

0 = 7.68 MHz (default)

1 = 15.36 MHz

6.2.11.10 PFS Sync Register

PFS Sync Register (CPFSSY)

read/write

Address: D089_H

Reset value: 0000_H

15	14	13	12	11	10	9	8
x	x	x	x	x	x	x	x
7	6	5	4	3	2	1	0
x	x	x	x			PFSSYNC(1:0)	

Note: 'x' = unused bits, read as 0.

PFSSYNC has to be written once during initialization (value doesn't care) to bring the rising edge of FSC close to PFS.

*Note: PFS and FSC are not exactly aligned. See **“AC Characteristics”** on **Page 249** for more information.*

6.2.11.11 Real-time Counter Register

RT Counter Register (CRTCNT) read Address: D08E_H

Reset value: 0000_H

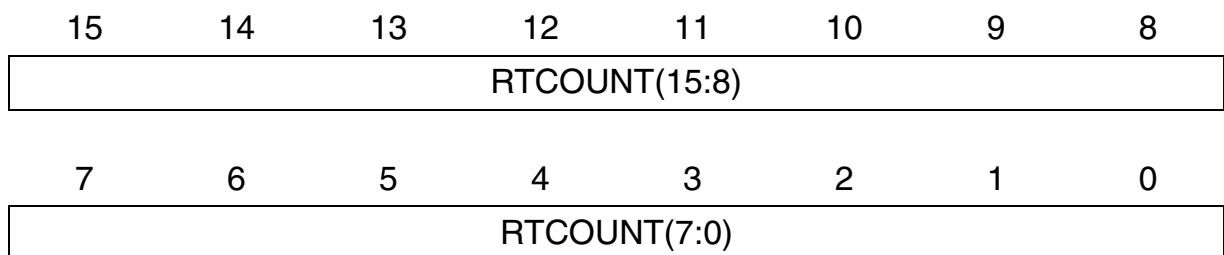

This 18-bit counter counts 8 kHz cycles. It is used by the software to time the handling of required tasks. One period of the counter (counting from 0000H to FFFFH and back to 0000H) is 32.768 sec. Only the 16 MSBs of the counter may be read by the OAK, therefore the actual resolution is 0.5 ms..

RTCOUNT(15:0) The 16 MSBs of the real-time counter

6.2.11.12 Strap Status Register

Strap Status Register (CSTRAP) read/ write Address: D08F_H

Reset value: 0000 0xxx xxxx xx10_B

15	14	13	12	11	10	9	8
x	x	x	x	x	STRAP(10:8)		
7	6	5	4	3	2	1	0
STRAP(7:0)							

Note: 'x' = unused bits, read as 0

Note: .

STRAP (10:0) This register enables the OAK to read the straps values, as sampled during reset

- bit 10 PCM Clock Master Strap
- bit 9:7 Test Mode Strap
- bit 6 Emulation Boot Strap
- bit 5 $\overline{\text{PLL Bypass}}$ Strap
- bit 4 $\overline{\text{DSP PLL Power-Down}}$ Strap
- bit 3 $\overline{\text{Boot}}$ Strap
- bit 2 $\overline{\text{Reset counter Bypass}}$ Strap
- bit 1 DCXO Fast-Synchronization Enable (read/write)
 - 0 = Linear (slow) synchronization (for DECT applications)
 - 1 = Fast synchronization (default)
- bit 0 Internal Source Clock Strap (read/ write)
 - 0 = PFS, PDC, DCL, FSC, DCL2000 are delayed by some ns (default)
 - 1 = PFS, PDC, DCL, FSC, DCL2000 are not delayed

7 Package Outlines

P-TQFP-100-3 (Plastic Thin Quad Flat Package)

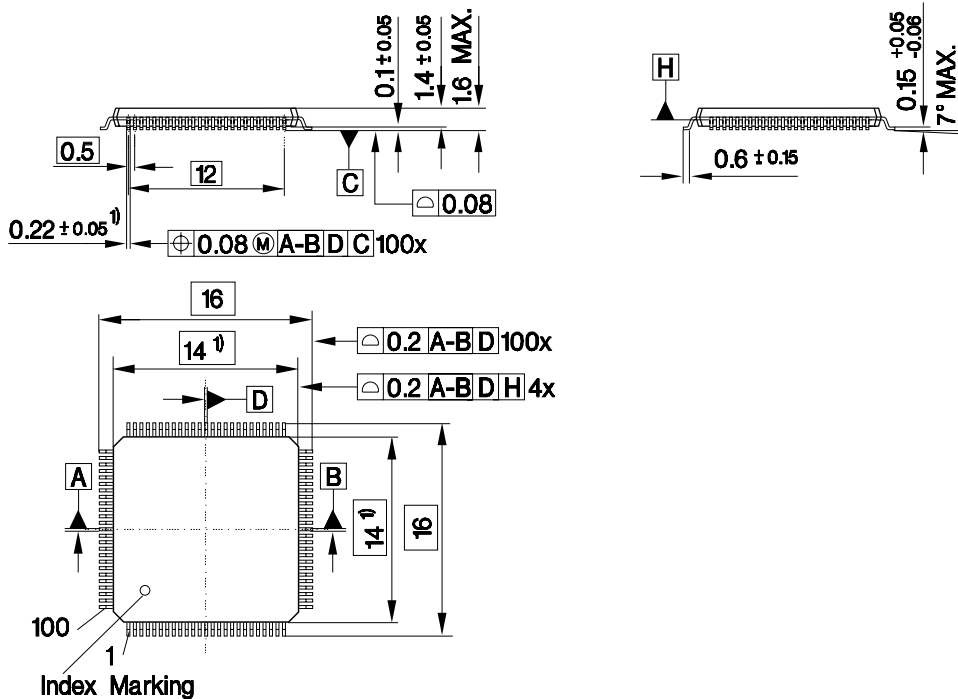

- Index Marking
- 1) Does not include plastic or metal protrusion of 0.25 max. per side
 - 2) Does not include dambar protrusion of 0.08 max. per side at max. material condition

GPM05247

Sorts of Packing

Package outlines for tubes, trays etc. are contained in our Data Book "Package Information".

SMD = Surface Mounted Device

Dimensions in mm

8 Electrical Characteristics and Timing Diagrams

8.1 Absolute Maximum Ratings

Parameter	Symbol	Limit Values	Unit
Storage temperature	T_{stg}	– 65 to 150	°C
IC supply voltage	V_{DD}	– 0.3 to 4.6	V
DC input voltage (except I/O)	V_I	– 0.3 to 6.0	V
DC output voltage (including I/O); output in high or low state	V_O	– 0.3 to $V_{DD} + 0.3$	V
DC output voltage (including I/O); output in tri-state	V_I, V_O	– 0.3 to 6.0	V
ESD robustness ¹⁾ HBM: 1.5 kΩ, 100 pF	$V_{ESD,HBM}$	2000	V

¹⁾ According to MIL-Std 883D, method 3015.7 and ESD Ass. Standard EOS/ESD-5.1-1993.
The Pins (TBD) are not protected against voltage stress > (TDB) V (versus V_S or GND). The (TBD) performance prohibits the use of adequate protective structures.

**Note: Stresses above those listed here may cause permanent damage to the device. Exposure to absolute maximum rating conditions for extended periods may affect device reliability.
Maximum ratings are absolute ratings; exceeding only one of these values may cause irreversible damage to the integrated circuit.**

Electrical Characteristics and Timing Diagrams

8.2 Operating Range

Parameter	Symbol	Limit Values		Unit
		min.	max.	
Power Supply Voltage	V_{DD}	3.13	3.47	V
Ground	V_{SS}	0	0	V
Voltage applied to input pins	V_{IN}	0	5.5	V
Voltage applied to output or I/O pins outputs enabled outputs high-Z	V_{OUT}	0	V_{DD}	V
	V_{OUT}	0	5.5	V
Operating temperature PEB	T_A	0	70	°C
Input transition rise or fall time	$\Delta t/\Delta v$	0	10	ns/V

Note: In the operating range, the functions given in the circuit description are performed.

Electrical Characteristics and Timing Diagrams

8.3 DC Characteristics

Parameter	Symbol	Limit Values		Unit	Test Condition
		min.	max.		
High-Level Input Voltage	V_{IH}	2.0	$V_{DD} + 3.3^{1)}$	V	$V_{OUT} \geq V_{OH} (\text{min})$
Low-Level Input Voltage	V_{IL}	-0.3	0.8	V	$V_{OUT} \leq V_{OL} (\text{max})$
High-Level Output voltage (all pins except DD0, DD1, DX, LTxD0, TxD0, TxD1)	V_{OH}	2.4		V	$V_{DD} = \text{min},$ $I_{OH} = -2 \text{ mA}$
Low-Level Output voltage (all pins except DD0, DD1, DX, LTxD0, TxD0, TxD1)	V_{OL}		0.4	V	$V_{DD} = \text{min},$ $I_{OL} = 2 \text{ mA}$
High-Level Output voltage (pins DD0, DD1, DX, LTxD0, TxD0, TxD1)	V_{OH}	2.4		V	$V_{DD} = \text{min},$ $I_{OH} = -7 \text{ mA}$
Low-Level Output voltage (pins DD0, DD1, DX, LTxD0, TxD0, TxD1)	V_{OL}		0.4	V	$V_{DD} = \text{min},$ $I_{OL} = 7 \text{ mA}$
Input leakage current	I_{IL}		1	μA	$V_{DD} = 3.3 \text{ V},$ $\text{GND} = 0 \text{ V};$ all other pins are floating; $V_{IN} = 0 \text{ V}$
Output leakage current	I_{OZ}		1	μA	$V_{DD} = 3.3 \text{ V},$ $\text{GND} = 0 \text{ V};$ $V_{OUT} = 0 \text{ V}$
Avg. power supply current	I_{Init}		266.5	mA	$V_{DD} = 3.3 \text{ V},$ $T_A = 25 \text{ }^\circ\text{C};$ PDC = 8 MHz DSP @ 61.44 MHz
	$I_{CC} (\text{AV})$		272.6		
	$I_{AP}^{2)}$		275		

1) max. value < 5.5 V

2) Power supply current for an application with 6 digital and 2 analogue phones including switching.

Note: The listed characteristics are ensured over the operating range of the integrated circuit. Typical characteristics specify mean values expected over the production spread. If not otherwise specified, typical characteristics apply at $T_A = 25 \text{ }^\circ\text{C}$ and the given supply voltage.

Electrical Characteristics and Timing Diagrams

8.4 Capacitances

Parameter	Symbol	Limit Values		Unit	Notes
		min.	max.		
Input Capacitance	C_{IN}		7	pF	$f_C = 1$ MHz, The pins, which are not under test, are connected to GND
I/O Capacitance	$C_{I/O}$		7	pF	
Output Capacitance	C_{OUT}		10	pF	
Crystal input capacitance (pin CLK16-XI)	C_{XIN}		3.3	pF	
Crystal output capacitance (pin CLK16-XO)	C_{XOUT}		3.3	pF	

8.5 Recommended 16.384 MHz Crystal Parameters

Parameter	Symbol	Limit Values		Unit	Test Condition
		min.	max.		
Motional Capacitance	C_1	25		fF	
Shunt Capacitance	C_0	7		pF	
External Load Capacitance	C_L	≤15		pF	
Resonance Resistance	R_r	≤30		Ω	
Frequency Calibration Tolerance		≤150		ppm	

8.6 AC Characteristics

8.6.1 DMA Access Timing

The exact behavior required from every μP interface signal during a DMA access, determined according to the following modes:

1. Motorola/Intel Mode: Determined by the MODE input pin.
2. Normal/Fly-By mode: Programmable mode, in the control register of the μP -interface.

In any mode, the $\overline{\text{DACK}}$ input alone is used to indicate that this is a DMA transaction, and to select the DMA mail-box. An activation of $\overline{\text{CS}}$ is not required in such cases.

8.6.1.1 DMA Access Timing In Motorola Mode

In this mode $\overline{\text{DS}}$ is used for timing the access, while $\overline{\text{R/W}}$ is used to distinguish between DMA read transactions and DMA write transactions. The $\overline{\text{R/W}}$ input signal is used differently in Normal mode and in Fly-By mode. The next table details the way in which $\overline{\text{R/W}}$ should be used in each mode, during DMA transactions:

Table 63 $\overline{\text{R/W}}$ Behavior During DMA Transactions in Normal and in Fly-By Mode

Mode	$\overline{\text{R/W}} = '0'$	$\overline{\text{R/W}} = '1'$
Normal (Non-Fly-By)	Write DMA transaction. (A response to DMA transmitter request)	Read DMA transaction. (A response to DMA receiver request)
Fly-By	Read DMA transaction. (A response to DMA receiver request)	Write DMA transaction. (A response to DMA transmitter request)

In Fly-By mode $\overline{\text{R/W}}$ is used inverted, because the same signal, $\overline{\text{R/W}}$, is required for concurrent accessing of an external memory device.

Electrical Characteristics and Timing Diagrams

Table 64 DMA Transaction timing in Motorola Mode

Parameter	Symbol	Limit Values		Unit	Test Conditions
		min.	max.		
$\overline{\text{DACK}}$ setup time to $\overline{\text{DS}}$ falling edge	t_{SAS}	7		ns	Output load capacity of 50 pF
$\overline{\text{DACK}}$ hold time after $\overline{\text{DS}}$ rising edge	t_{HSA}	5		ns	
D-bus setup time to $\overline{\text{DS}}$ rising edge	t_{SDS}	5		ns	
D-bus hold time after $\overline{\text{DS}}$ rising edge	t_{HSD}	8		ns	
DREQT/DREQR delay after $\overline{\text{DS}}$ falling edge	t_{DSR}	0	36	ns	
R/ $\overline{\text{W}}$ setup time to $\overline{\text{DS}}$ falling edge	t_{SRWS}	7		ns	
R/ $\overline{\text{W}}$ hold time after $\overline{\text{DS}}$ rising edge	t_{HSRW}	5		ns	
$\overline{\text{DS}}$ pulse width and interval between $\overline{\text{DS}}$ pulses	t_{WS}	30		ns	
D-bus valid after $\overline{\text{DS}}$ falling edge	t_{DSDV}	0	22	ns	
D-bus float (high impedance) after $\overline{\text{DS}}$ rising edge	t_{DSDT}	0	15	ns	

Electrical Characteristics and Timing Diagrams

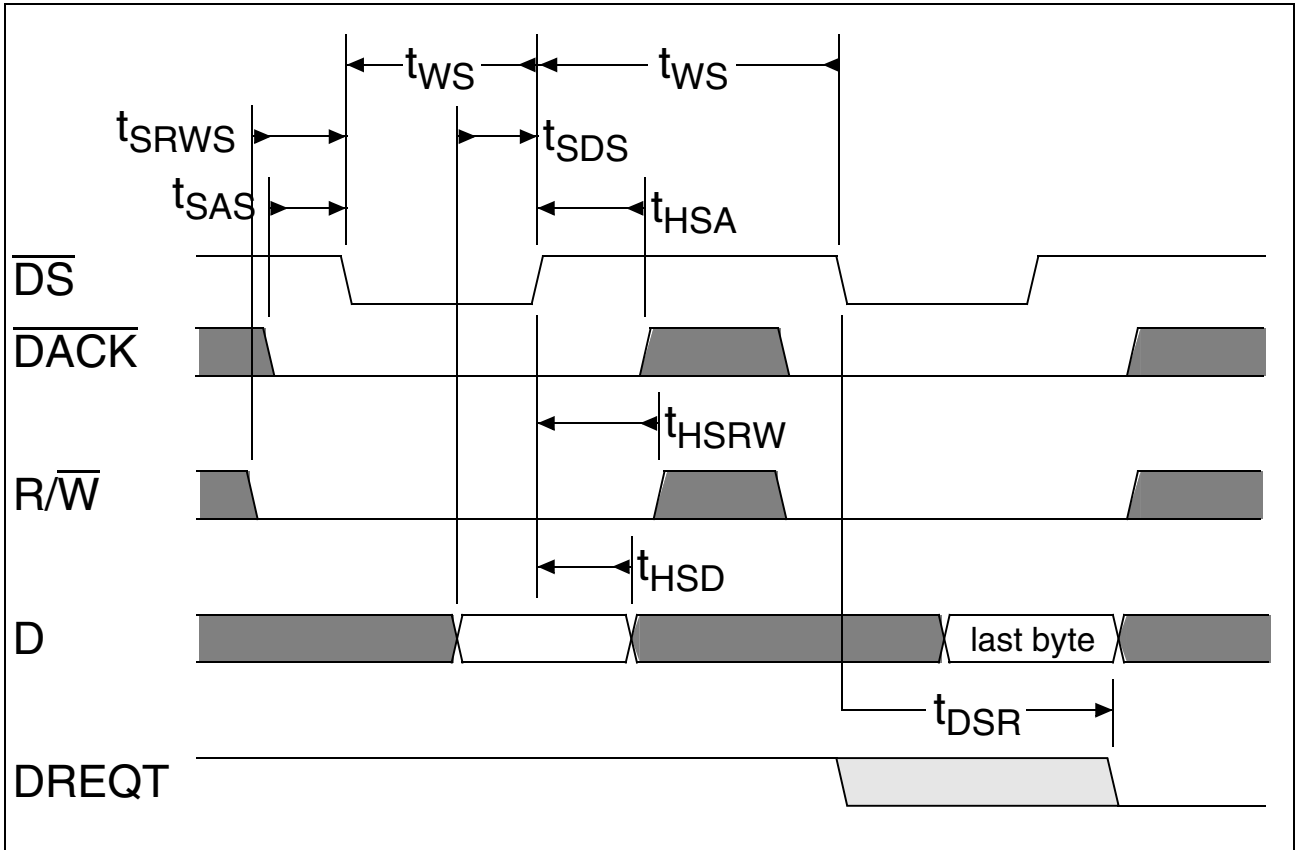

Figure 59 DMA Write-Transaction Timing in Motorola Mode

Note: R/\overline{W} is described in Normal mode. In Fly-by mode, R/\overline{W} should be high during DMA write transactions.

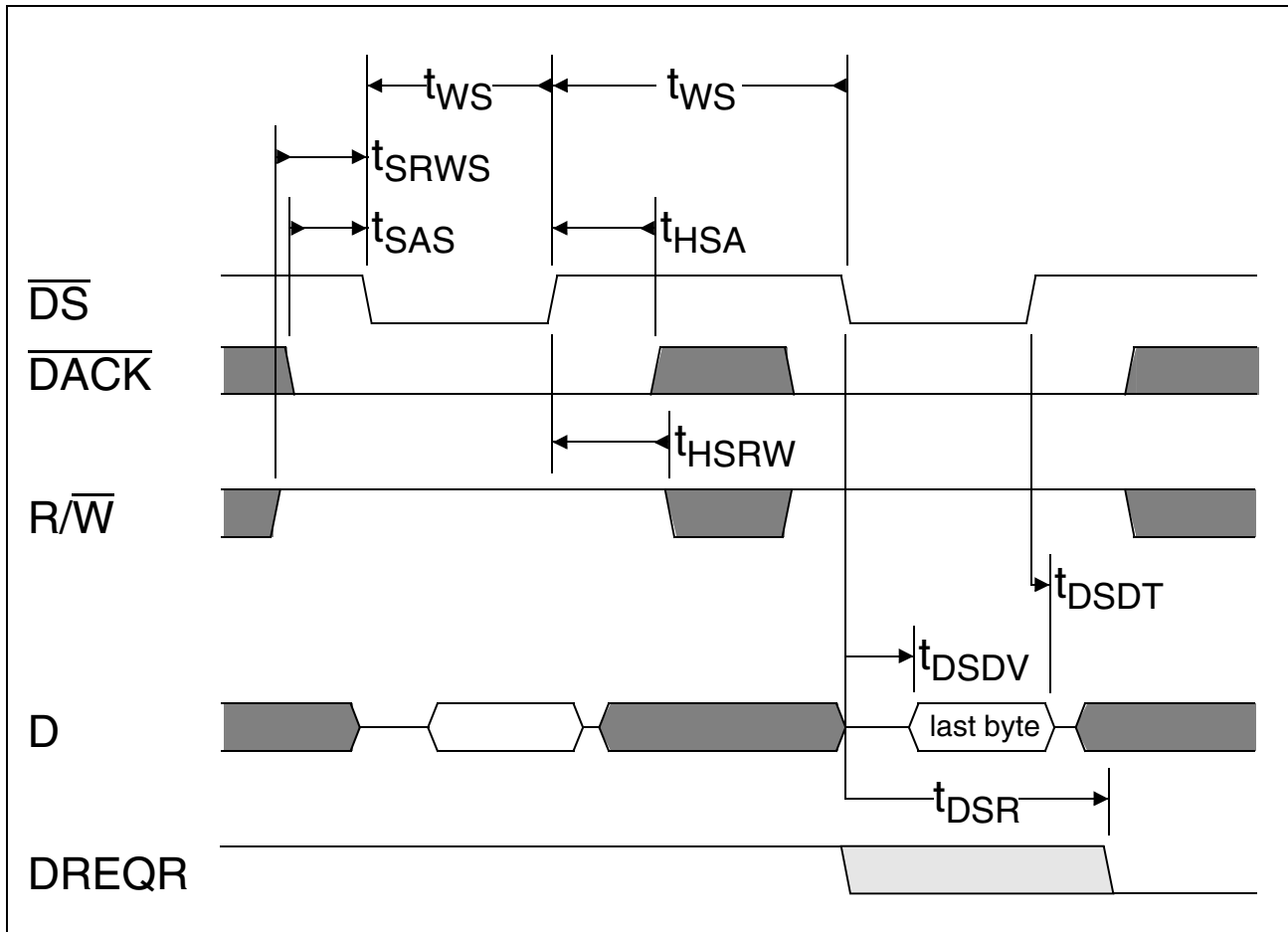

Figure 60 DMA Read-Transaction Timing in Motorola Mode

Note: R/\bar{W} is described in Normal mode. In Fly-by mode, R/\bar{W} should be low during DMA read transactions.

8.6.1.2 DMA Access Timing In Intel/Infineon Mode

In this mode \bar{R} and \bar{W} are used for timing the access and to determine whether it's a DMA-read cycle or DMA-write cycle. \bar{R} and \bar{W} input signals are used in opposite ways in Normal mode and in Fly-By mode. The next table details the way in which \bar{R} and \bar{W} should be used in each mode, during DMA transactions:

Electrical Characteristics and Timing Diagrams

Table 65 R/ \bar{W} Behavior During DMA Transactions in Normal and in Fly-By Modes

Mode	$\bar{R} = '1', \bar{W} = '0'$	$\bar{R} = '0', \bar{W} = '1'$
Normal (Non-Fly-By)	Write DMA transaction. (A response to DMA transmitter request)	Read DMA transaction. (A response to DMA receiver request)
Fly-By	Read DMA transaction. (A response to DMA receiver request)	Write DMA transaction. (A response to DMA transmitter request)

In Fly-By mode \bar{R} and \bar{W} are used inverted, because these signals are required also for concurrent accessing of an external memory device.

Table 66 DMA Transaction Timing in Intel/Infineon Mode

Parameter	Symbol	Limit Values		Unit	Test Conditions
		min.	max.		
\bar{DACK} setup time to \bar{W} or \bar{R} falling edge	t_{SAW} t_{SAR}	7		ns	Output load capacity of 50 pF
\bar{DACK} hold time after \bar{W} or \bar{R} rising edge	t_{HWA} t_{HRA}	5		ns	
D-bus setup time to \bar{W} rising edge	t_{SDW}	5		ns	
D-bus hold time after \bar{W} rising edge	t_{HWD}	8		ns	
DREQT/DREQR delay after \bar{W} or \bar{R} falling edge	t_{DWR} t_{DRR}	0	36	ns	
\bar{W} pulse width and interval between \bar{W} pulses	t_{WW}	30		ns	
\bar{R} pulse width and interval between \bar{R} pulses	t_{WR}	30		ns	
D-bus valid after \bar{R} falling edge	t_{DRDV}	0	22		
D-bus float (high impedance) after \bar{R} rising edge	t_{DRDT}	0	15		

Electrical Characteristics and Timing Diagrams

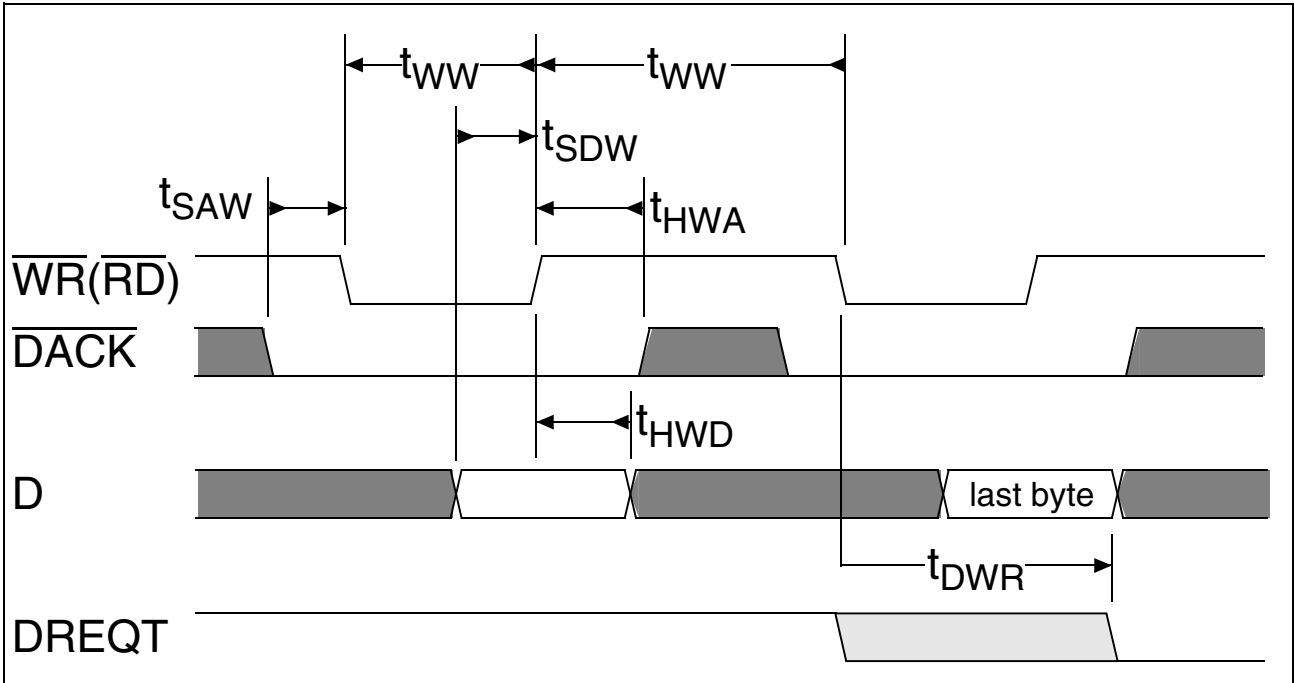

Figure 61 DMA Write-Transaction Timing in Intel/Infineon Mode

Note: The figure describes a transaction in Normal mode. In Fly-by mode, \overline{RD} is used during DMA write transactions, instead of \overline{WR} .

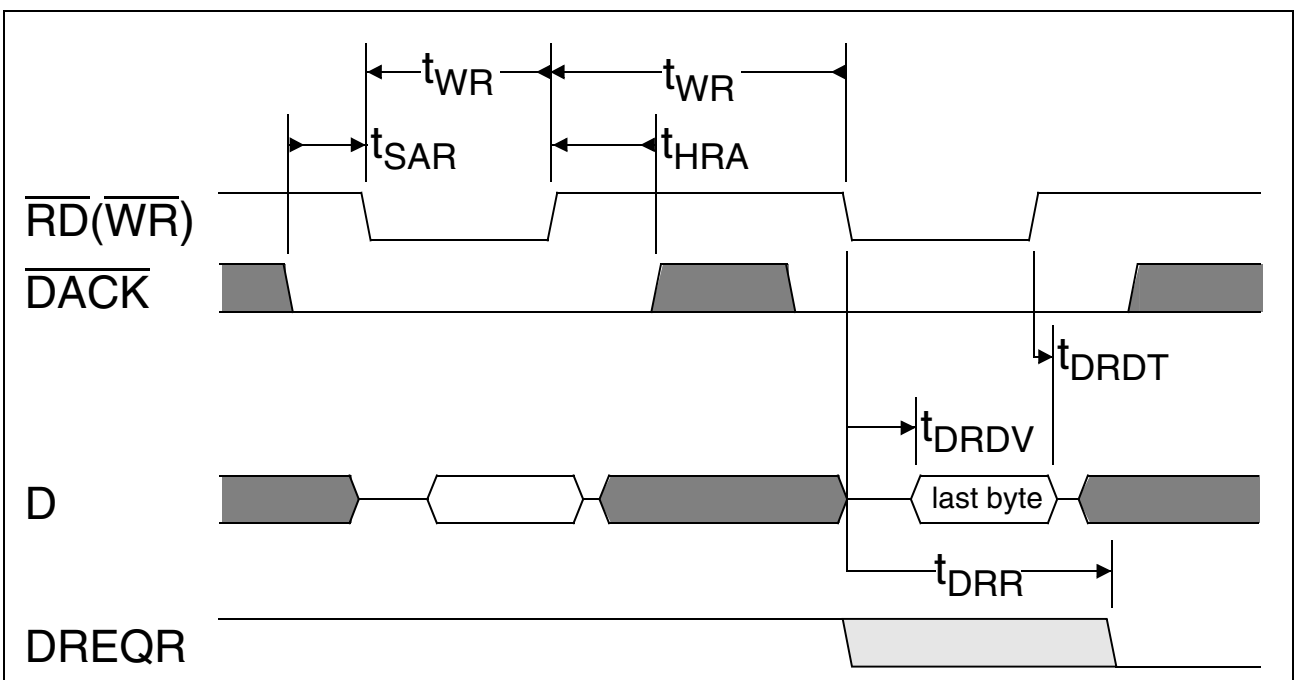

Figure 62 DMA Read-Transaction Timing in Intel/Infineon Mode

Note: The figure describes a transaction in Normal mode. In Fly-by mode, \overline{WR} is used during DMA read-transactions, instead of \overline{RD} .

Electrical Characteristics and Timing Diagrams

8.6.2 μ P Access Timing

μ P accesses DELIC by an activation of Address and \overline{CS} .

1. By driving the MODE pin 'high' the user chooses Motorola Work Mode, by driving it 'low' - Intel/Infineon Work Mode. The pin is sampled by \overline{RESET} rising edge.
2. Moreover, there is a difference between work with Multiplexed Address/Data Bus and Demultiplexed Address and Data Buses (in Intel/Infineon Mode). In Motorola Mode Demultiplexed Buses only used. The selection between Multiplexed and Demultiplexed is done by the manner of use of ALE.

8.6.2.1 μ P Access Timing in Motorola mode

In this mode R/\overline{W} distinguishes between Read and Write interactions, and \overline{DS} is used for timing.

Table 67 Timing for Write Cycle in Motorola Mode

Parameter	Symbol	Limit Values		Unit	Notes
		min.	max.		
R/\overline{W} setup time before $\overline{DS} \times \overline{CS}$ rising edge	t_{SRWS}	17		ns	Output load capacity of 50 pF
R/\overline{W} hold time after $\overline{DS} \times \overline{CS}$ rising edge	t_{HRWS}	5		ns	
A-bus setup time before $\overline{DS} \times \overline{CS}$ rising edge	t_{SAS}	22		ns	
A-bus hold time after $\overline{DS} \times \overline{CS}$ rising edge	t_{HAS}	6		ns	
D-bus setup time before $\overline{DS} \times \overline{CS}$ rising edge	t_{SDS}	5		ns	
D-bus hold time after $\overline{DS} \times \overline{CS}$ rising edge	t_{HDS}	8		ns	
$\overline{DS} \times \overline{CS}$ pulse width	t_{WS}	17		ns	

Note: $\overline{DS} \times \overline{CS}$ is active (low) when both, \overline{DS} and \overline{CS} , are active (low)

Electrical Characteristics and Timing Diagrams

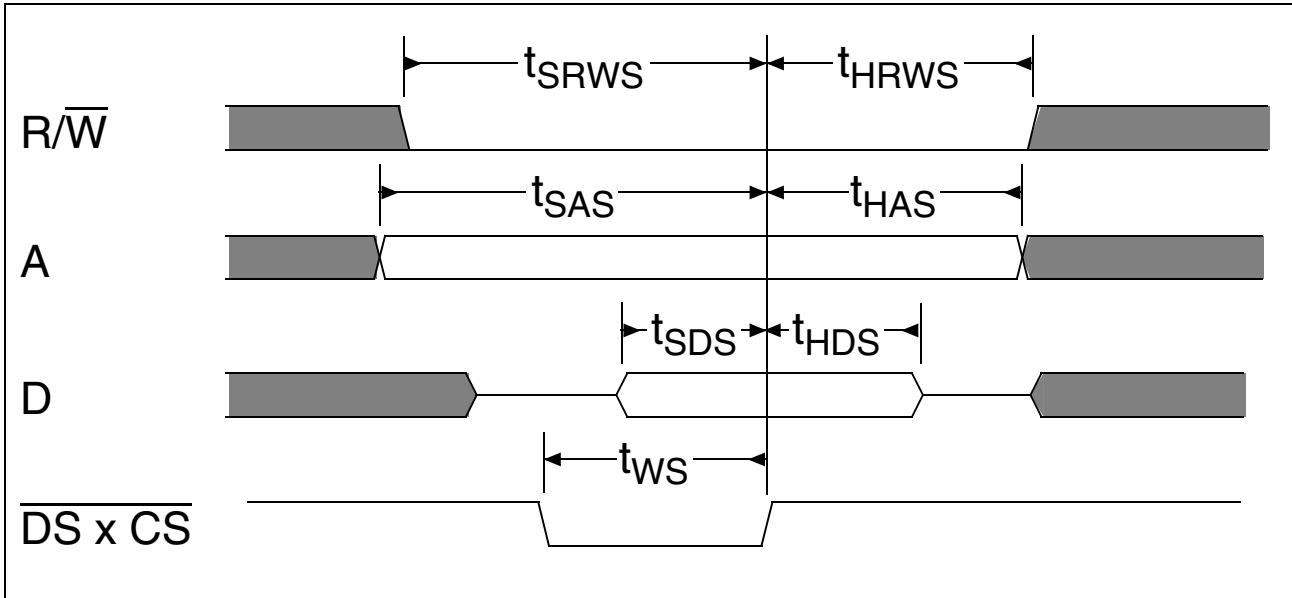

Figure 63 Write Cycle Motorola Mode

Table 68 Timing for Read Cycle In Motorola Mode

Parameter	Symbol	Limit Values		Unit	Notes
		min.	max.		
R/W setup time before $\overline{DS} \times \overline{CS}$ falling edge	t_{SRWS}	0		ns	Output load capacity of 50 pF
R/W hold time after $\overline{DS} \times \overline{CS}$ rising edge	t_{HRWS}	5		ns	
A-bus valid to D-bus valid	t_{DAD}	0	28	ns	
$\overline{DS} \times \overline{CS}$ falling edge to D-bus	t_{DSD}	0	28	ns	
D-bus float after $\overline{DS} \times \overline{CS}$ rising edge	t_{DSDH}	0	16	ns	

Note: $\overline{DS} \times \overline{CS}$ is active (low) when both, \overline{DS} and \overline{CS} are active (low)

Electrical Characteristics and Timing Diagrams

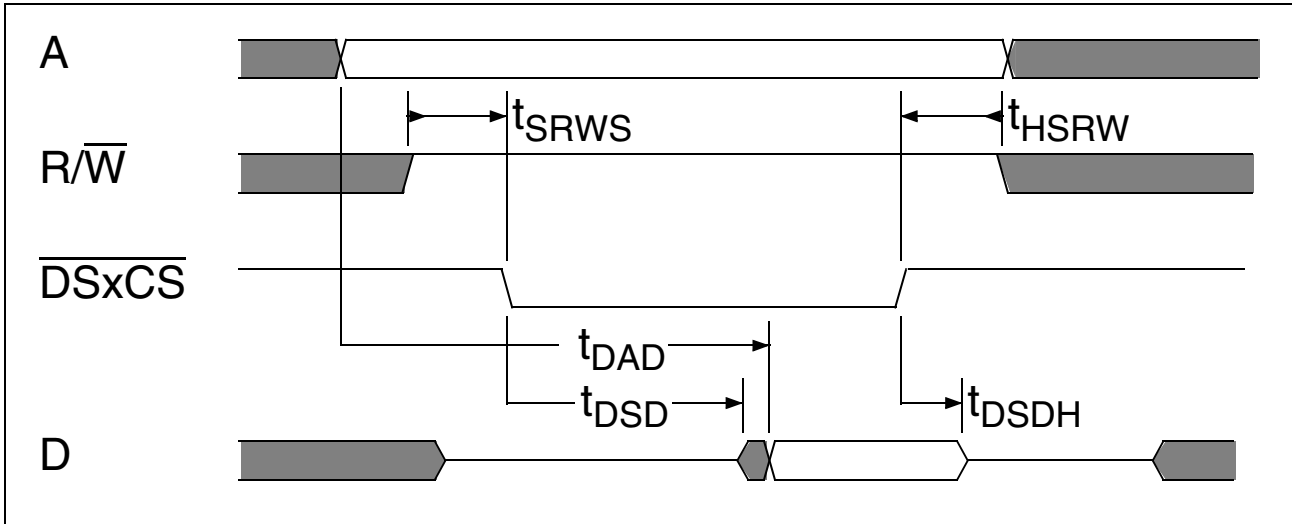

Figure 64 Read Cycle Motorola Mode

8.6.2.2 μ P Access Timing in Intel/Infineon Mode

In this mode driving \overline{RD} 'low' causes Read access, driving \overline{WR} 'low' causes Write access.

In order to work on demultiplexed bus ALE has to be driven 'high' all the time.

Table 69 Timing for Write Cycle in Intel/Infineon Demultiplexed Mode

Parameter	Symbol	Limit Values		Unit	Notes
		min.	max.		
A-bus setup time before \overline{WR} rising edge	t_{SAW}	12		ns	Output load capacity of 50 pF
A-bus hold time after \overline{WR} rising edge	t_{HAW}	5		ns	
\overline{CS} setup time before \overline{WR} rising edge	t_{SCW}	12		ns	
\overline{CS} hold time after \overline{WR} rising edge	t_{HCW}	5		ns	
D-bus setup time before \overline{WR} rising edge	t_{SDW}	6		ns	
D-bus hold time after \overline{WR} rising edge	t_{HDW}	8		ns	
WR pulse width	t_{WW}	7		ns	

Electrical Characteristics and Timing Diagrams

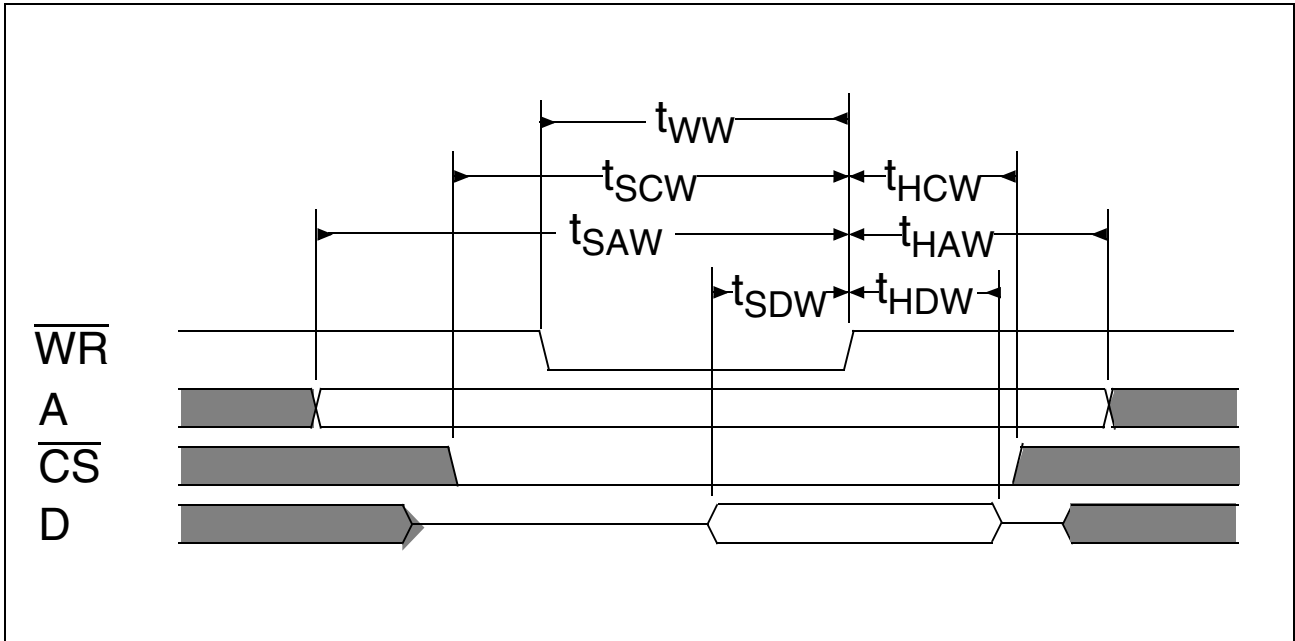

Figure 65 Write Cycle Intel/Infineon Demultiplexed Mode

Table 70 Timing For Read Cycle in Intel/Infineon Demultiplexed Mode

Parameter	Symbol	Limit Values		Unit	Notes
		min.	max.		
A-bus valid to D-bus valid	t_{DAD}	0	28	ns	Output load capacity of 50 pF
$\overline{RD} \times \overline{CS}$ falling edge to D-bus	t_{DRD}	0	28	ns	
D-bus float after $\overline{RD} \times \overline{CS}$ rising edge	t_{DRDH}	0	16	ns	

Note: $\overline{RD} \times \overline{CS}$ is active (low) when both, \overline{RD} and \overline{CS} are active (low)

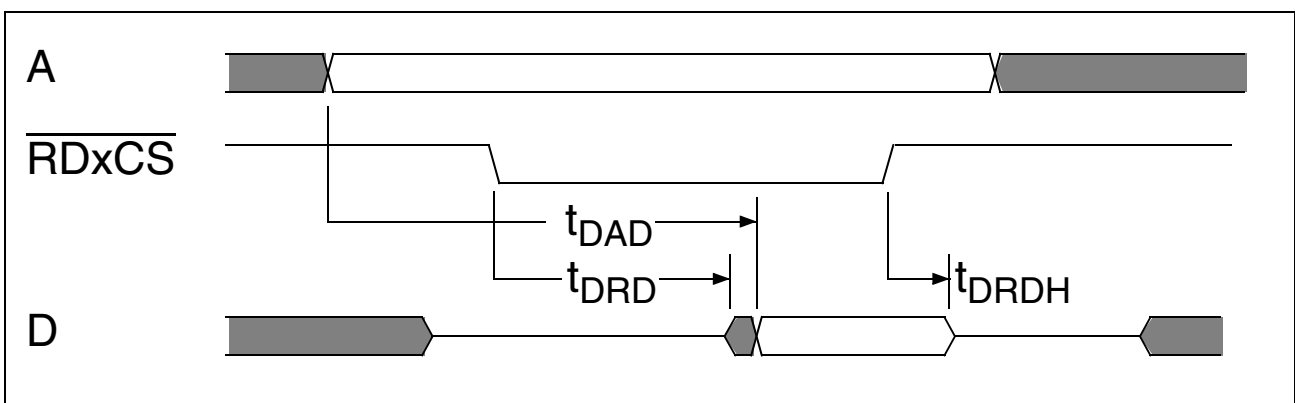

Figure 66 Read Cycle Intel/Infineon Demultiplexed Mode

Electrical Characteristics and Timing Diagrams

Timing for Multiplexed Bus

In this mode ALE pin is used in order to lock the address, driven over the multiplexed A/D bus.

Table 71 Timing for Write Cycle in Intel/Infineon Multiplexed Mode

Parameter	Symbol	Limit Values		Unit	Notes
		min.	max.		
A-bus setup time before ALE falling edge	t_{SAL}	12		ns	Output load capacity of 50 pF
A-bus hold time after ALE falling edge	t_{HAL}	5		ns	
ALE pulse width	t_{WL}	7		ns	
\overline{CS} setup time before \overline{WR} rising edge	t_{SCW}	14		ns	
\overline{CS} hold time after \overline{WR} rising edge	t_{HCW}	5		ns	
D-bus setup time before \overline{WR} rising edge	t_{SDW}	6		ns	
D-bus hold time after \overline{WR} rising edge	t_{HDW}	8		ns	
ALE hold time after \overline{WR} rising edge	t_{HLW}	5		ns	
WR pulse width	t_{WW}	7		ns	

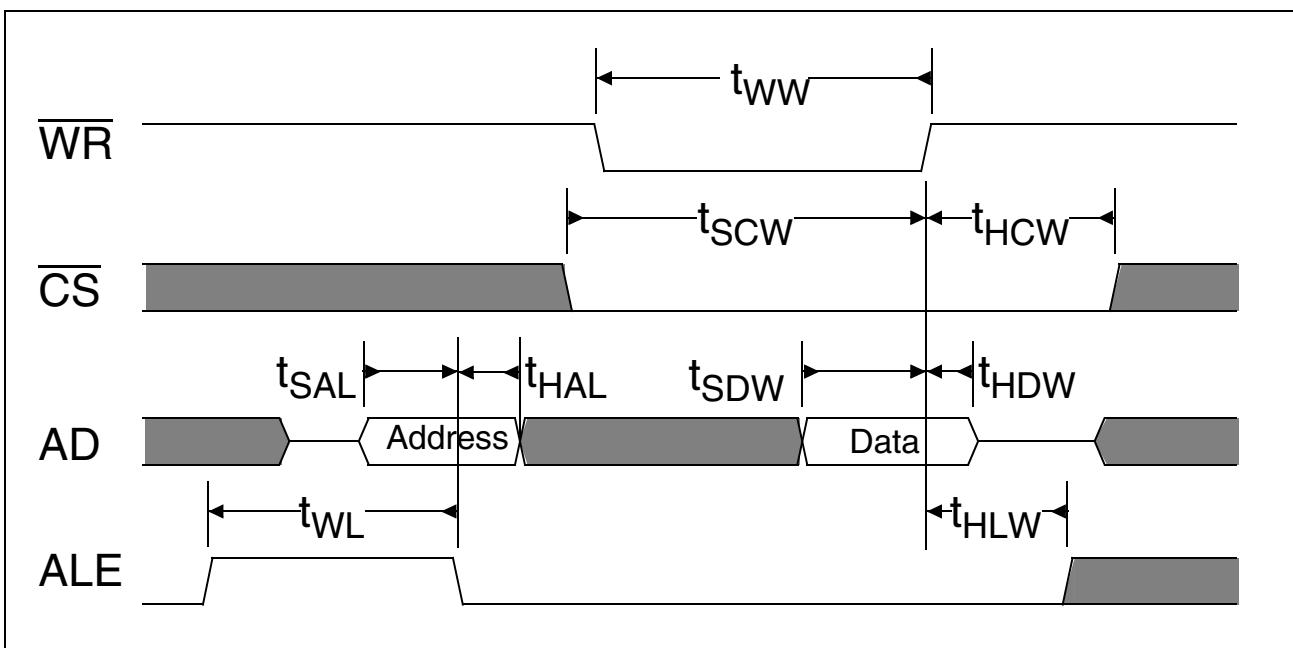

Figure 67 Write Cycle Intel/Infineon Multiplexed Mode

Electrical Characteristics and Timing Diagrams

Table 72 Timing For Read Cycle in Intel/Infineon Multiplexed Mode

Parameter	Symbol	Limit Values		Unit	Notes
		min.	max.		
ALE low before $\overline{RD} \times \overline{CS}$ falling edge	t_{HRL}	5		ns	Output load capacity of 50 pF
ALE hold time after $\overline{RD} \times \overline{CS}$ rising edge	t_{HLR}	5		ns	
ALE pulse width	t_{WL}	7		ns	
A-bus setup time before ALE falling edge	t_{SAL}	12		ns	
A-bus hold time after ALE falling edge	t_{HAL}	5		ns	
$\overline{RD} \times \overline{CS}$ falling edge to D-bus valid	t_{DRD}	0	28	ns	
D-bus float after $\overline{RD} \times \overline{CS}$ rising edge	t_{DRDH}	0	16	ns	

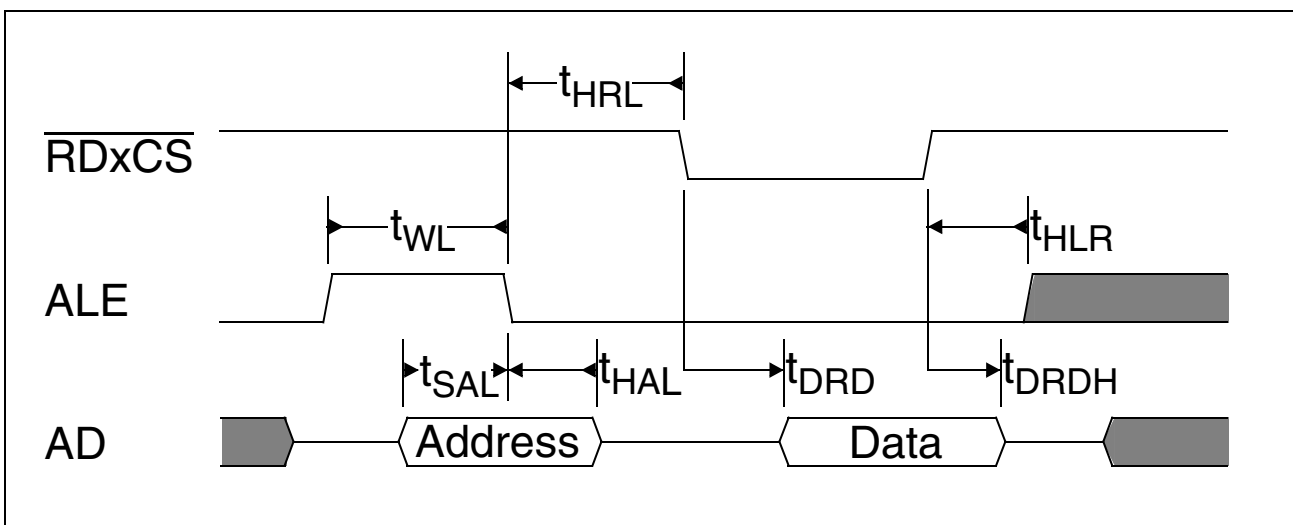

Figure 68 Read Cycle in Intel/Infineon Multiplexed Mode

8.6.3 Interrupt Acknowledge Cycle Timing

The IREQ (Interrupt REQuest) output signal of the DELIC is activated as a result of a DSP writing operation to the OCMD register (OAK mailbox command register). Such an operation sets the OAK mailbox busy bit (OBUSY), which drives directly the IREQ output signal. The IREQ signal may be masked, by programming the MASK bit within the μ P-interface Control Register (UPCR).

The μ P may force the DELIC to drive the interrupt-vector over the data-bus, by activation (low) of the interrupt acknowledge input signal (\overline{IACK}). In Motorola mode an interrupt acknowledge cycle consists of one \overline{IACK} pulse, during which the interrupt vector is issued by the DELIC. In Intel/Infineon mode an interrupt acknowledge cycle consists of

Electrical Characteristics and Timing Diagrams

two $\overline{\text{IACK}}$ pulses, and the interrupt vector is issued as a response to the second one. The vector's source the OAK mailbox vector register (OVEC). The value stored in this register is determined by the OAK, by writing operation.

IREQ is not deactivated by the $\overline{\text{IACK}}$ pulses directly, but by μP writing access to OBUSY.

Table 73 Interrupt Acknowledge Cycle Timing

Parameter	Symbol	Limit Values		Unit	Notes
		min.	max.		
D-bus valid after $\overline{\text{IACK}}$ falling edge	t_{DADV}	0	31	ns	Output load capacity of 50 pF
D-bus float after $\overline{\text{IACK}}$ rising edge	t_{DADT}	0	19	ns	
$\overline{\text{IACK}}$ pulse width	t_{WA}	25		ns	
Interval between two $\overline{\text{IACK}}$ pulses	t_{HA}	10^1		ns	
IREQ delay after $\overline{\text{WR}}$ or $\overline{\text{DS}}$	t_{DWI}		28	ns	

1) Valid only for Intel/Infineon mode.

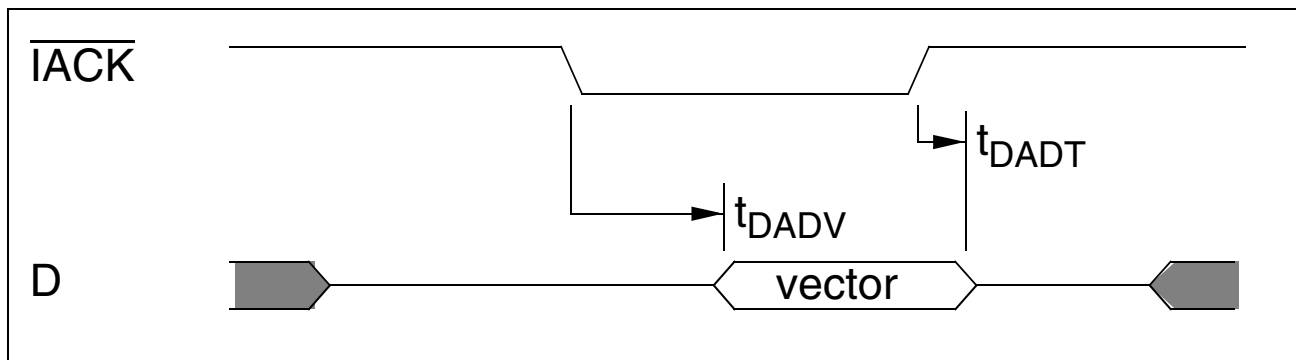

Figure 69 Interrupt Acknowledge Cycle Timing in Motorola Mode

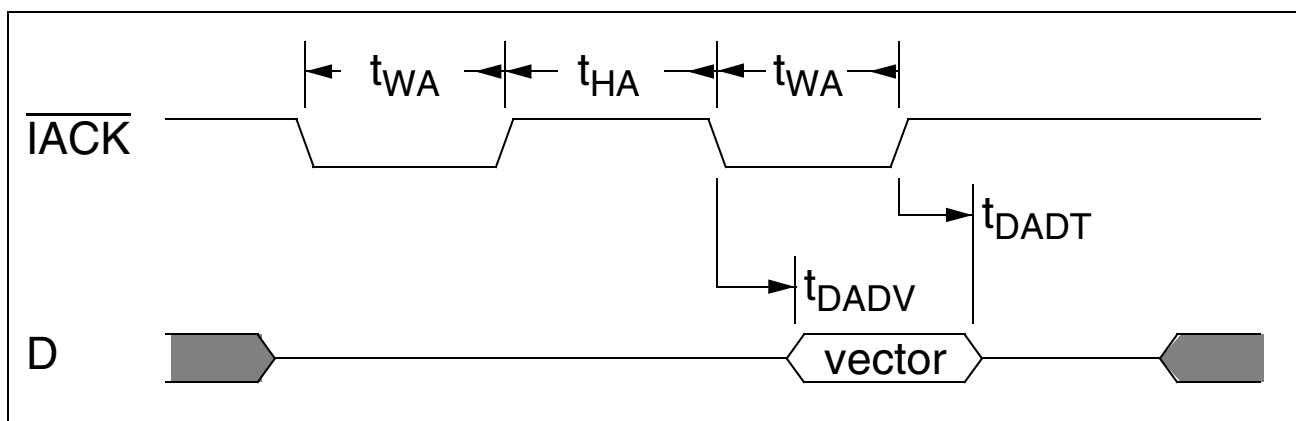

Figure 70 Interrupt Acknowledge Cycle Timing in Intel/Infineon Mode

Electrical Characteristics and Timing Diagrams

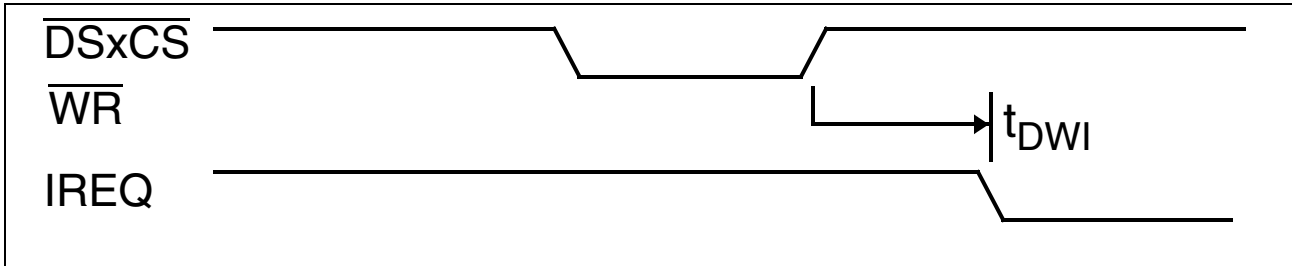

Figure 71 IREQ Deactivation Timing

Note: IREQ is deactivated due to μP write operation to OBUSY register. In Motorola mode \overline{DS} and \overline{CS} together time the write access. In Intel mode \overline{WR} alone times the write access. For more details regarding the timing required during write access to the DELIC, refer to section 8.6.2. The other signals required for a write operation to OBUSY in each mode, are assumed to be driven appropriately.

8.6.4 IOM-2 Interface Timing

Table 74 IOM-2 Interface Timing

Parameter	Symbol	Limit Values			Unit	Notes
		min.	typ.	max.		
DU0/DU1 setup time before DCL falling edge	t_{UDF}	10			ns	
DU0/DU1 hold time after DCL falling edge	t_{UHF}	10			ns	
DRDY setup time before DCL falling edge ¹⁾	t_{YDF}	10			ns	
DRDY hold time after DCL falling edge	t_{YHE}	10			ns	
DD0/DD1 delay after DCL rising edge	t_{DDE}	7		27	ns	Output load capacity of 50 pF
DD0/DD1 float after DCL rising edge	t_{DFE}	6		22	ns	

¹⁾ DRDY is sampled only once during every IOM-2 channel, with the first D-bit (D0). For more details refer to [“Support of DRDY Signal from QUAT-S” on Page 103](#)

Note: FSC and DCL are outputs of the DELIC. Yet, DCL is used also in the DELIC for sampling and driving of the other signals of the IOM-2 interface, and thus the timing of these signals is related to DCL.

Electrical Characteristics and Timing Diagrams

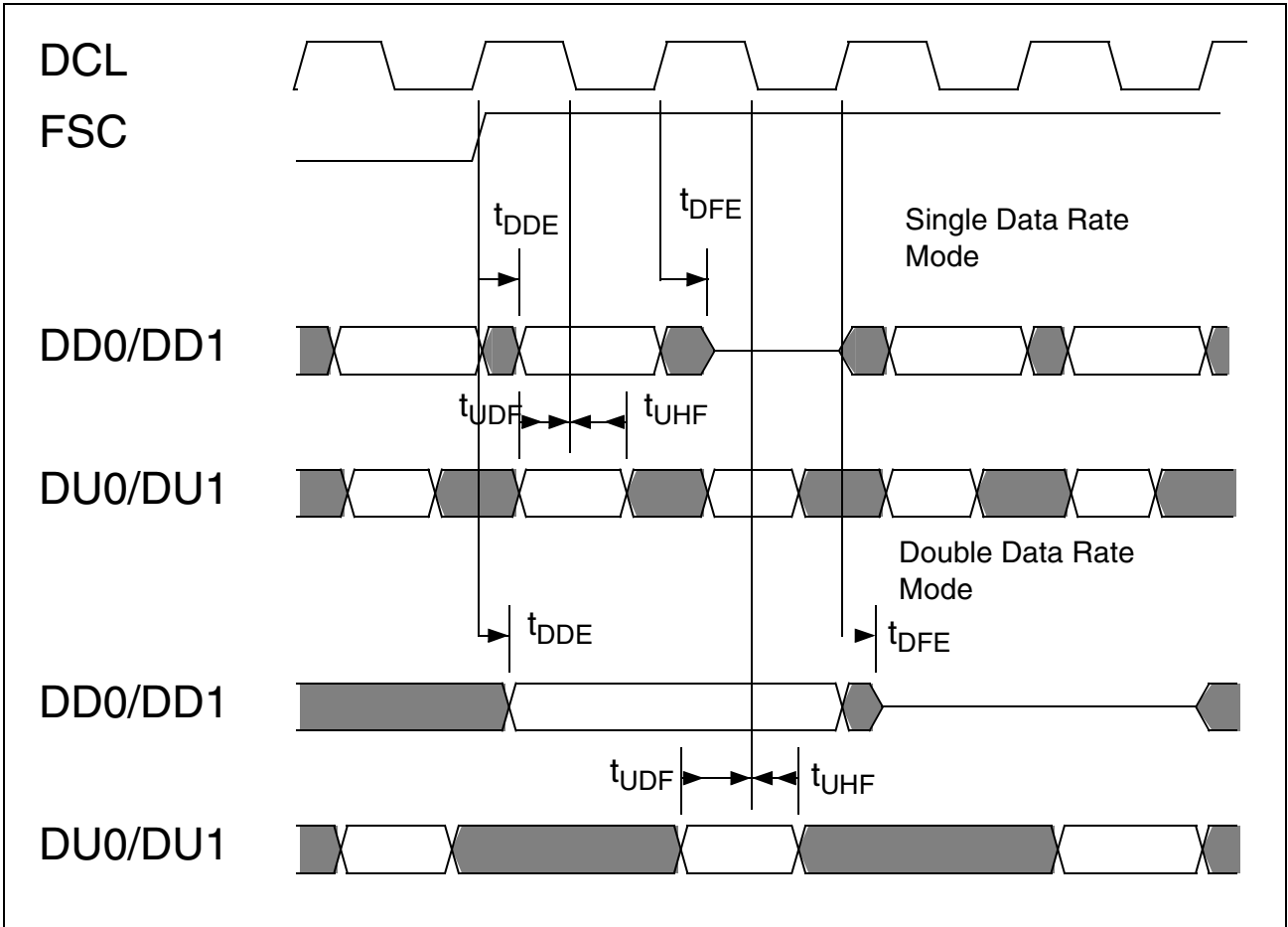

Figure 72 IOM-2 Interface Timing

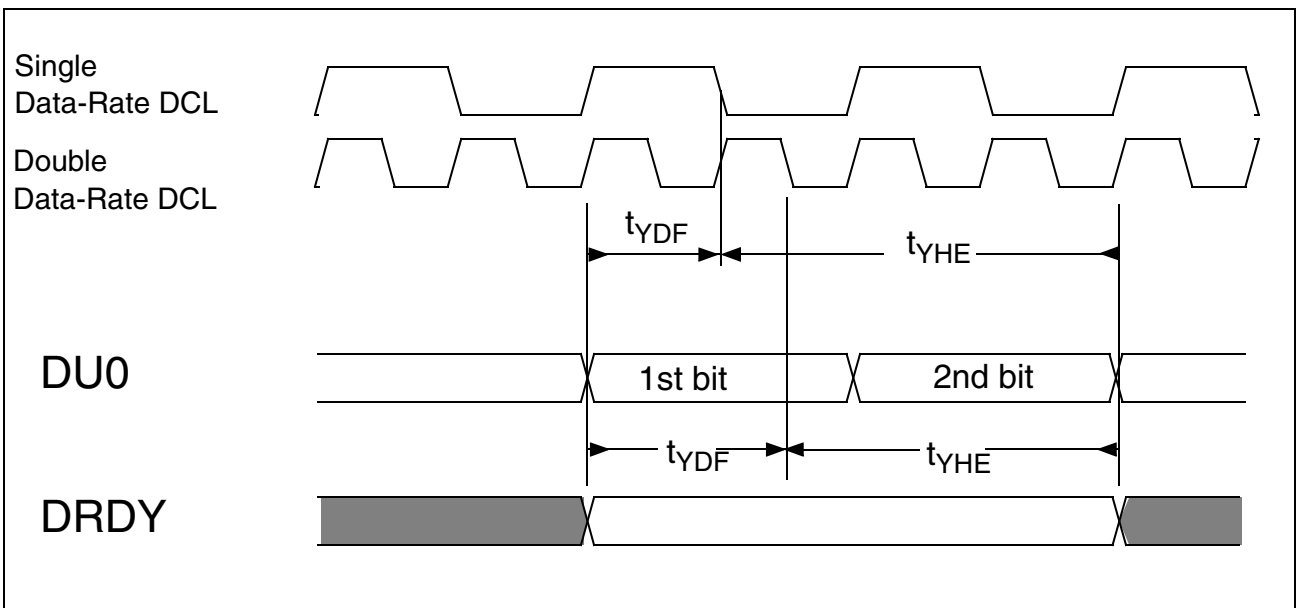

Figure 73 DRDY Timing

Electrical Characteristics and Timing Diagrams

Table 75 DCL (IOM-2 Data Clock) Timing

Parameter	Symbol	Limit Values			Unit	Notes
		min.	typ.	max.		
DCL Clock Period	t_{DCP}		2.604		μs	DCL = 384 kHz
			1.302		μs	DCL = 768 kHz
			651		ns	DCL = 1536 kHz
			488		ns	DCL = 2048 kHz
			244		ns	DCL = 4096 kHz
DCL Duty Cycle		48	50	52	%	

Note: Usually DSP-clock is generated internally by the internal PLL, in a frequency of 61.44 MHz. If on the other hand a lower frequency clock is provided via CLK_DSP input pin, the frequency of DCL should not exceed the frequency of DSP-clock-frequency / 4 (DSP clock frequency divided by 4), in order to guarantee a proper operation of the DELIC.

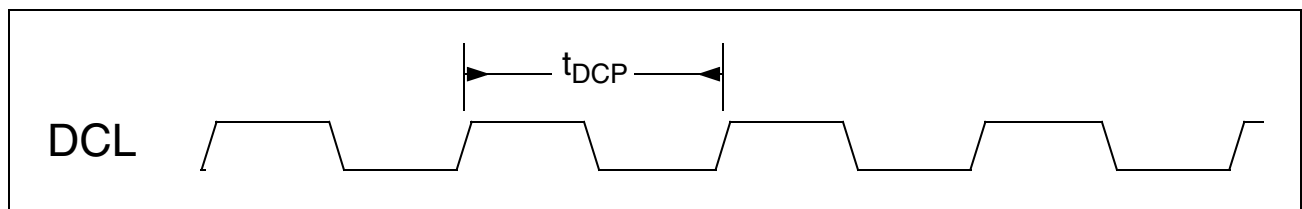

Figure 74 DCL Timing IOM-2

Table 76 FSC (IOM-2 and IOM-2000 Frame-Sync) Timing

Parameter	Symbol	Limit Values			Unit	Notes
		min.	typ.	max.		
FSC delay after DCL rising edge ¹⁾	t_{FDE}	-10		10	ns	Output load capacity of up to 50 pF on both, PFS and DCL
FSC Clock Period	t_{FSC}		125		μs	8 kHz
FSC Clock Period High in a long-pulse FSC cycle ²⁾	t_{HLC}	112	112.5	113	μs	

Electrical Characteristics and Timing Diagrams

Table 76 FSC (IOM-2 and IOM-2000 Frame-Sync) Timing (cont'd)

Parameter	Symbol	Limit Values			Unit	Notes
		min.	typ.	max.		
FSC Clock Period High in a short-pulse FSC cycle ³⁾	t_{HSC}	2.5	2.604	2.7	μs	DCL = 384 kHz
		1.2	1.302	1.4	μs	DCL = 768 kHz
		640	651	660	ns	DCL = 1536 kHz
		480	488	490	ns	DCL = 2048 kHz
		235	244	255	ns	DCL = 4096 kHz

- 1) FSC rises and falls by DCL rising edge, and should be sampled with the falling edge of DCL, in the other chips, connected to the IOM-2 interface of the DELIC.
- 2) In a long-pulse FSC cycle, FSC is generated with a 50% duty cycle. FSC Clock Period Low is the complement of this parameter to 125 μs .
- 3) In a short-pulse FSC cycle, FSC is high for exactly one cycle of DCL, thus it is dependent on the frequency of DCL. FSC Clock Period Low is the complement of this parameter to 125 μs .

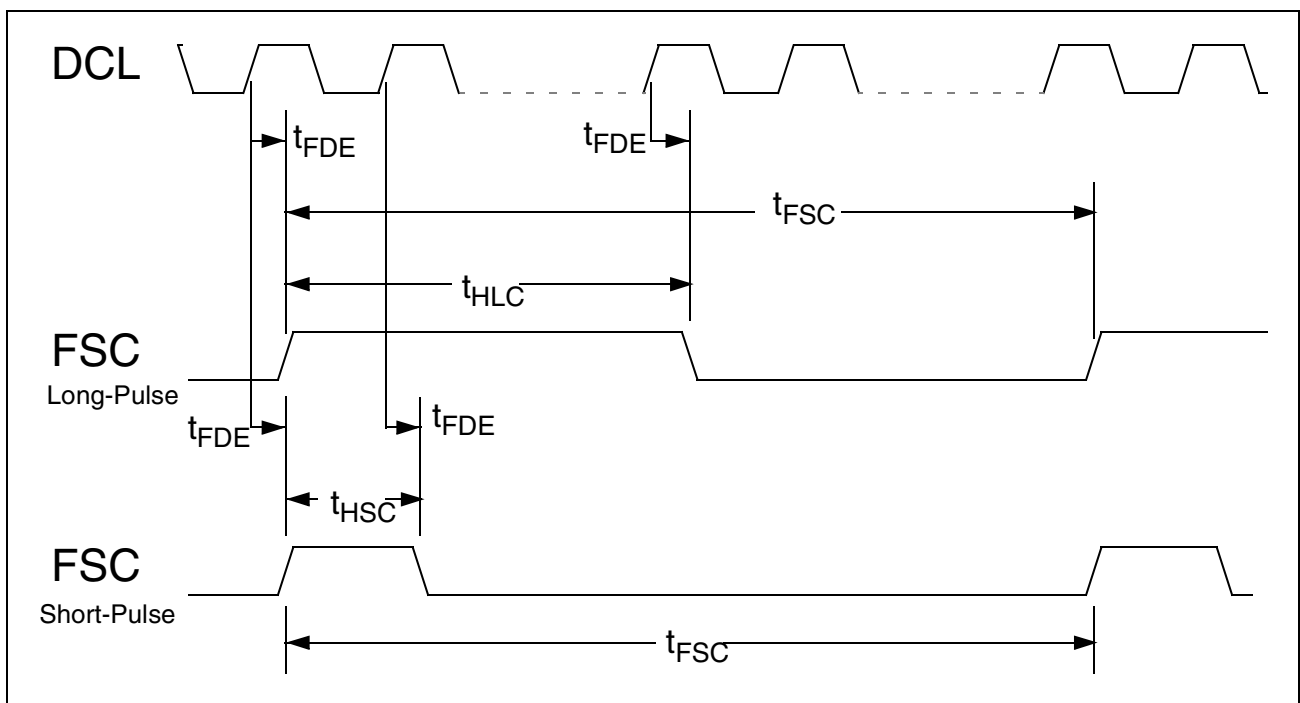

Figure 75 FSC Timing IOM-2

Electrical Characteristics and Timing Diagrams

8.6.5 PCM Interface Timing

Table 77 PCM Interface Timing

Parameter	Symbol	Limit Values			Unit	Notes
		min.	typ.	max.		
RxD0..3 setup time before PDC falling edge	t_{RPF}	10			ns	
RxD0..3 hold time after PDC falling edge	t_{RHF}	10			ns	
PFS setup time before PDC falling edge ¹⁾	t_{PSP}	10			ns	In slave mode, when PFS and PDC are inputs.
PFS setup time before PDC rising edge ²⁾	t_{PPR}	10			ns	
PFS hold time after PDC falling edge ¹⁾	t_{HPF}	10			ns	
PFS hold time after PDC rising edge ²⁾	t_{HPR}	10			ns	
PFS Pulse Width (high) ³⁾	t_{PPW}	25			ns	
PFS delay after PDC ⁴⁾	t_{PDP}	-10		10	ns	In master mode, when PFS and PDC are outputs.
PFS Clock Period	t_{PCP}		125		μ s	
PFS Duty Cycle		48	50	52	%	
TxD0..3 delay after PDC rising edge	t_{TPF}	2		19	ns	TxD0..3
TxD0..3 float after PDC rising edge	t_{TFR}	2		20	ns	
TSC0..3 delay after PDC rising edge	t_{TDR}	2		19	ns	

1) In 8 kHz PFS - slave mode, PFS is sampled by PDC falling edge. The first PDC cycle in which FSC is sampled as logic-1 after a sampling of logic-0, is considered as the first cycle of the new PCM frame. Also see [“PCM Master/Slave Mode Clocks Selection” on Page 144](#)

2) In 4 kHz PFS - slave mode, PFS is sampled by PDC rising edge. In order to work appropriately in this mode, PFS should be sampled as logic-1 only once every frame. The cycle in which PFS is sampled as logic-1 is considered as the first cycle of the new frame. Also see [“PCM Master/Slave Mode Clocks Selection” on Page 144](#)

3) Inside the DELIC, PFS is also sampled by DSP-clock (61.44 MHz). Since this clock (DSP-clock) is not visible for the user, a pulse width of more than one 61.44 MHz cycle is required, in order to guarantee an appropriate sampling.

Electrical Characteristics and Timing Diagrams

- 4) In PCM Master mode (PFS and PDC are in output mode) PFS rises with a rising edge of PDC, and it's designed to be sampled with the falling edge of PDC at any (slave) chip connected to the PCM interface. The first PDC cycle in which PFS is sampled as logic-1 after a sampling of logic-0, is considered as the first cycle of the new PCM frame.

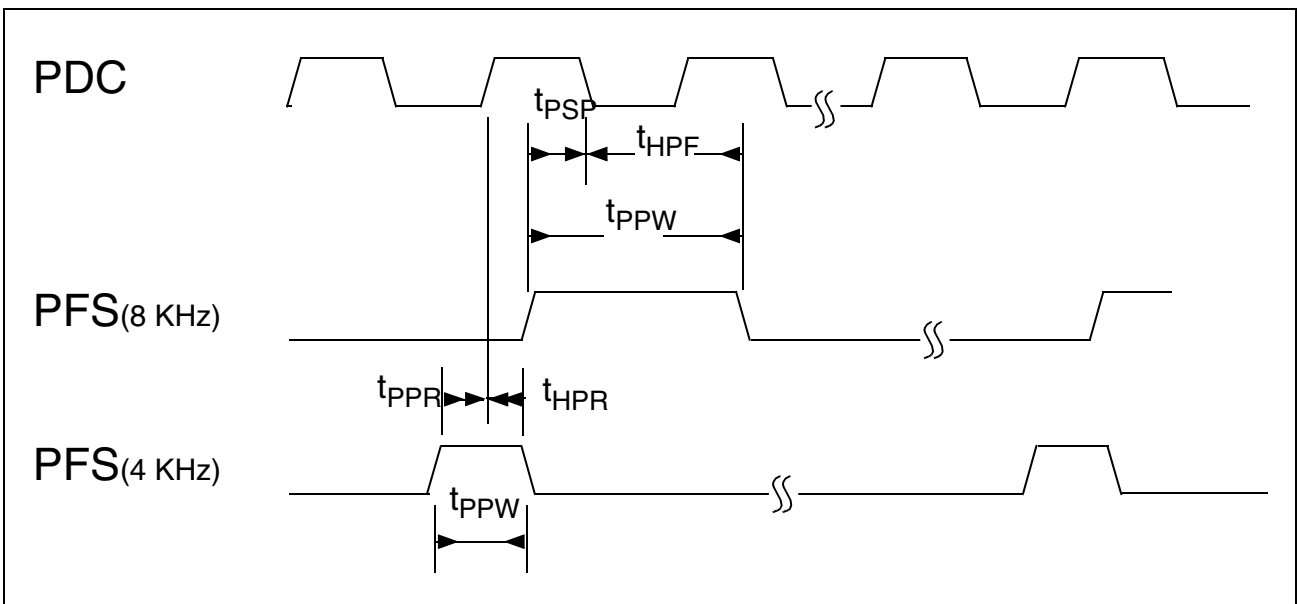

Figure 76 PFS Timing in Slave Mode (Input PCM Clocks)

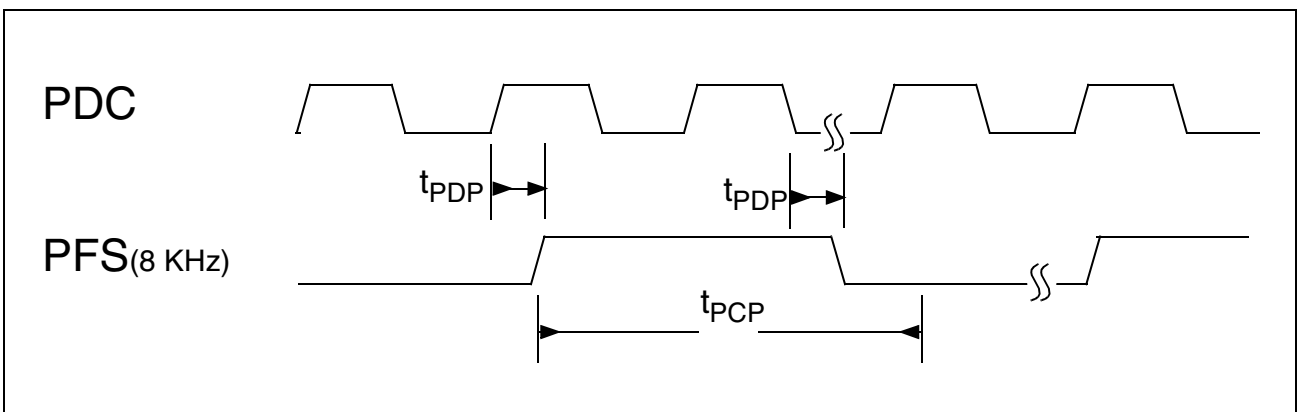

Figure 77 PFS Timing in Master Mode

Electrical Characteristics and Timing Diagrams

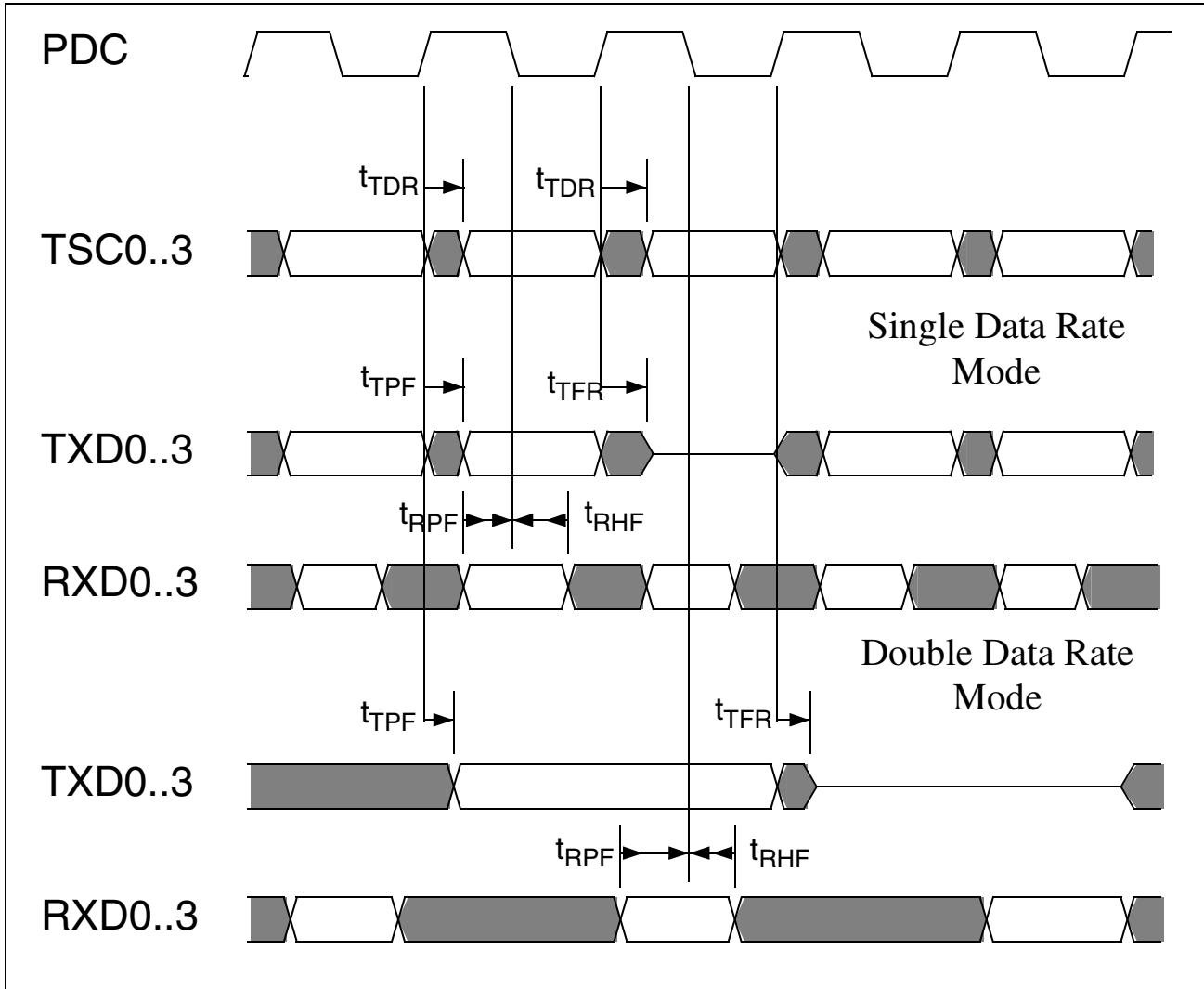

Figure 78 PFS Interface Timing

Table 78 PDC (PCM Data Clock) Timing in Master Mode (Output Mode)

Parameter	Symbol	Limit Values			Unit	Notes
		min.	typ.	max.		
PDC Clock Period	t_{PCP}		488		ns	PDC = 2048 kHz
			244		ns	PDC = 4096 kHz
			122		ns	PDC = 8192 kHz
			61		ns	PDC = 16384 kHz
PDC Duty Cycle	t_{PDC}	48		52	%	

Electrical Characteristics and Timing Diagrams

Note: Usually DSP-clock is generated internally by the internal PLL, in a frequency of 61.44 MHz. If on the other hand a lower frequency clock is provided via CLK_DSP input pin, the frequency of PDC (input or output) should not exceed the frequency of DSP-clock-frequency / 4 (DSP clock frequency divided by 4), in order to guarantee a proper operation of the DELIC.

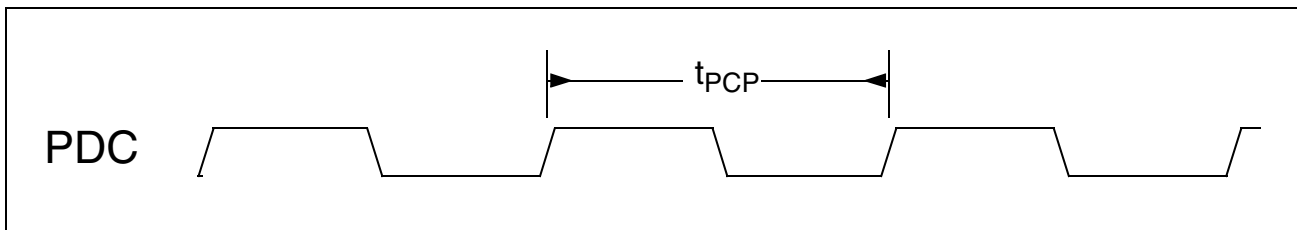

Figure 79 PDC Parameters

Table 79 PDC Timing in Input Mode

Parameter	Symbol	Limit Values			Unit	Notes
		min.	typ.	max.		
PDC Minimum High Pulse	t_{PMH}	22			ns	In Input Mode
PDC Minimum Low Pulse	t_{PML}	22			ns	In Input Mode

Note: The Minimum pulse width (high or low) of PDC depends on the DSP clock frequency. Usually this clock is generated internally by the internal PLL, in a frequency of 61.44 MHz. In this case the values in the table above are valid. If a lower frequency for DSP-clock is provided via CLK_DSP input pin, and PDC is used as input, the low/high pulse width of PDC should not be smaller than 1.5 X DSP-clock-cycle (DSP-clock-cycle is the cycle time of the provided DSP clock).

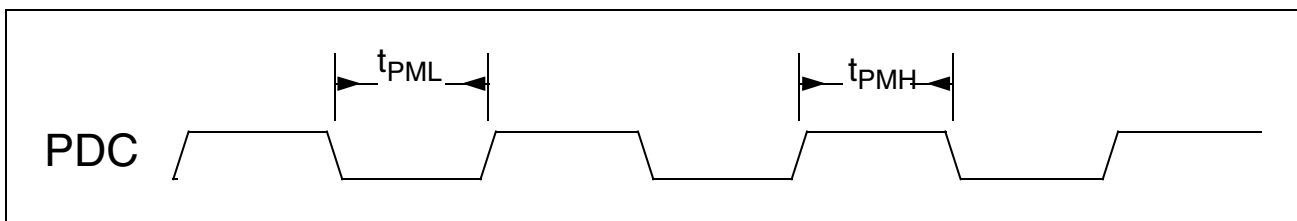

Figure 80 PDC Timing in Input Mode

Electrical Characteristics and Timing Diagrams

8.6.6 IOM-2000 Interface Timing

Table 80 IOM-2000 Interface Timing

Parameter	Symbol	Limit Values			Unit	Notes
		min.	typ.	max.		
DR setup time before DCL_2000 falling edge	t_{DSF}	1			ns	
DR hold time after DCL_2000 falling edge	t_{DHF}	12			ns	
DX delay after DCL_2000 rising edge	t_{XDR}			20	ns	
STAT setup time before DCL_2000 falling edge	t_{SSF}	1			ns	
STAT hold time after DCL_2000 falling edge	t_{SHF}	12			ns	
CMD delay after DCL_2000 rising edge	t_{CDR}			20	ns	
FSC rising edge delay after DCL_2000 rising edge ¹⁾ (In both, long and short pulse FSC cycles)	t_{FRE}	-10		10	ns	CFSC:EFSCD = '0' ²⁾
		6		26	ns	CFSC:EFSCD = '1' ³⁾
FSC falling edge delay after DCL_2000 rising edge	t_{FFE}	-10		26	ns	Long-pulse FSC cycle
FSC falling edge delay after DCL_2000 falling edge ⁴⁾	t_{FFF}	70			ns	Short-pulse FSC cycle DCL_2000 = 3072 kHz DCL = 4096 kHz
FSC Clock Period	t_{FCD}		125		μ s	

1) FSC is the same pin used for the IOM-2 interface (Table 76). FSC rises with a rising edge of DCL_2000, and it's designed to be sampled with the falling edge of DCL_2000 at any chip connected to the IOM-2000 interface. The first DCL-2000 cycle in which FSC is sampled as logic-1 after a sampling of logic-0, is considered as the first cycle of the new IOM-2000 frame. When a long-pulse FSC cycle is issued, FSC always rises and falls with a rising edge of DCL_2000, and it is generated with a 50% duty cycle.

2) FSC Control Register : EFSCD (bit 2) = '0', i.e. no delay between DCL_2000 rising edge and FSC rising edge.
"FSC Control Register" on Page 239

Electrical Characteristics and Timing Diagrams

- 3) FSC Control Register : EFSCD (bit 2) = '1', i.e. FSC rising edge is delayed in one cycle of 61.44 MHz (16 ns) after DCL_2000 rising edge. Special mode designed for working with the VIP. **“FSC Control Register” on Page 239**
- 4) When a short-pulse FSC cycle is issued, FSC high period is one DCL (of IOM-2) cycle long. In the worst case, when DCL_2000 = 3072 kHz and DCL = 4096 kHz, FSC high pulse is shorter than one cycle of DCL_2000, but yet it is stable from the rising edge and until at least 70 ns after the falling edge of DCL_2000 within this single cycle. Thus setup and hold times of FSC around DCL_2000's falling edge are guaranteed.

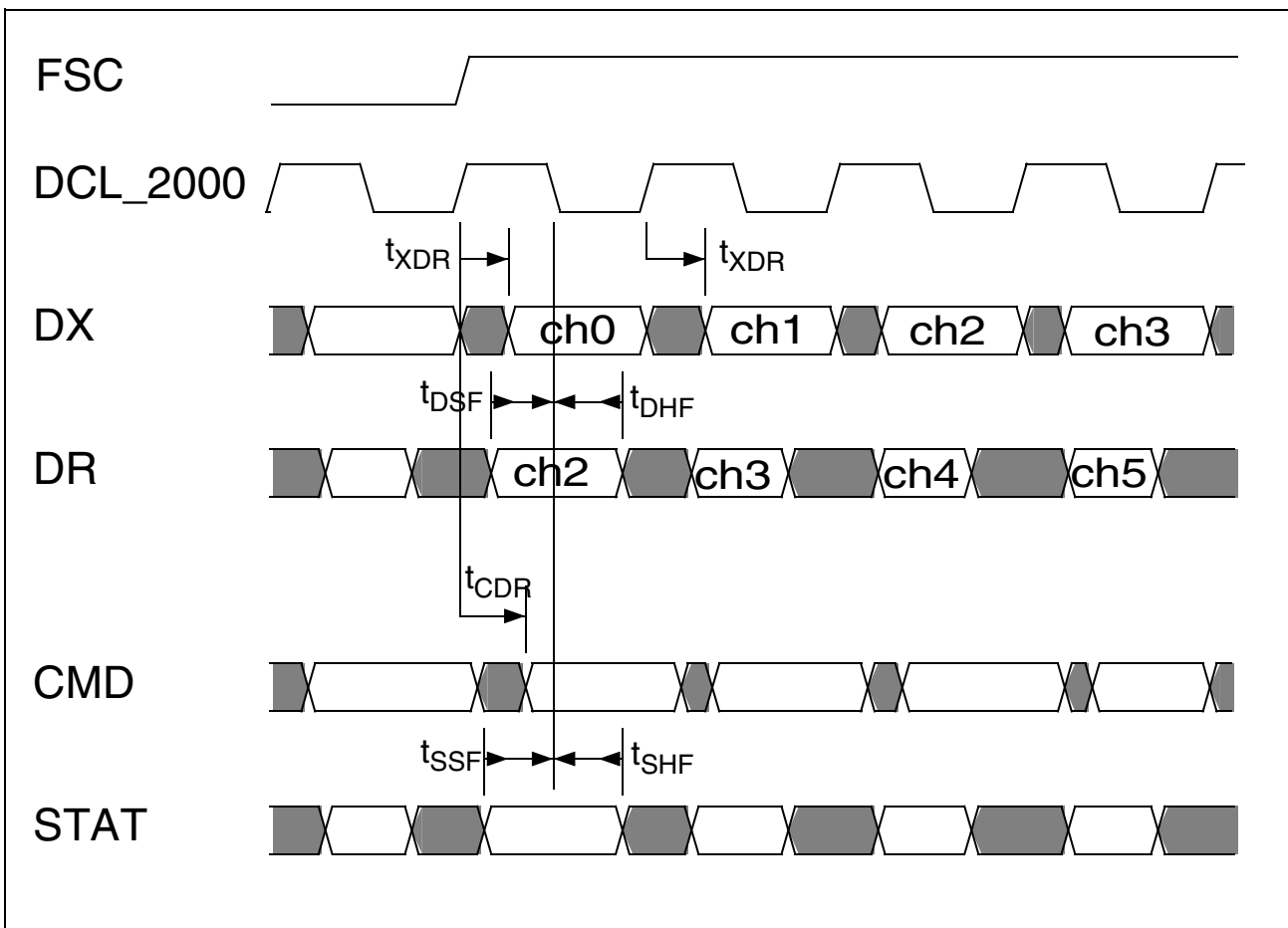

Figure 81 IOM-2000 Interface Timing

Electrical Characteristics and Timing Diagrams

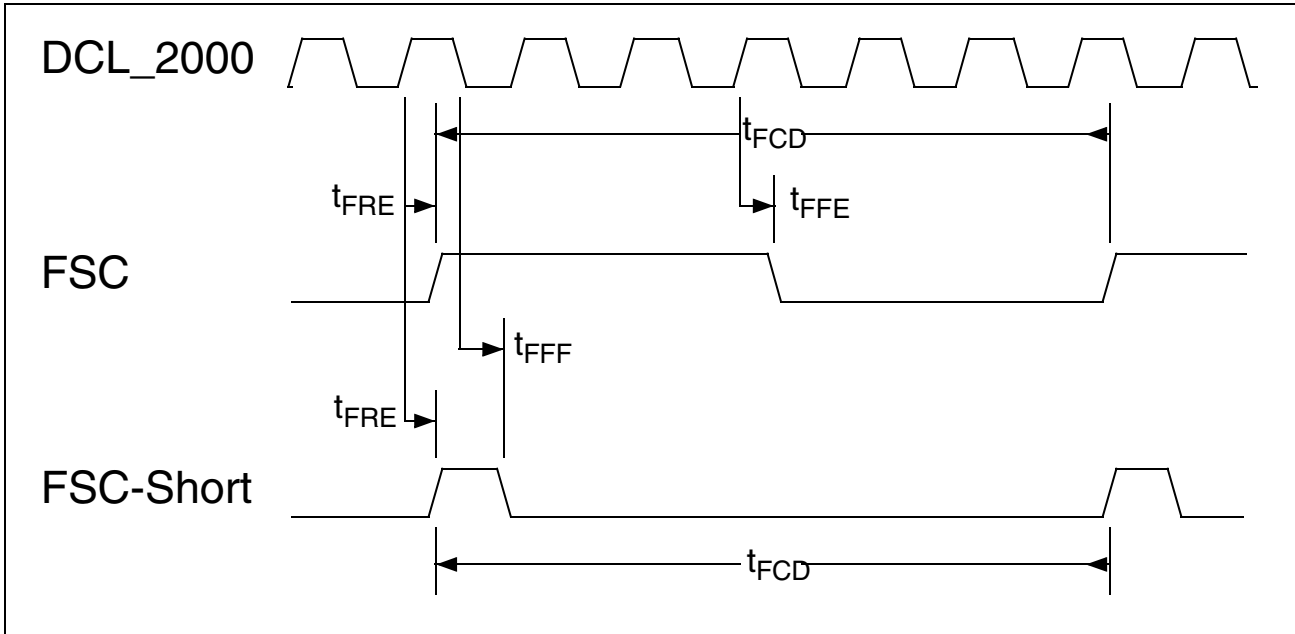

Figure 82 FSC Timing IOM-2000

Table 81 DCL_2000 (IOM-2000 Data Clock) Timing

Parameter	Symbol	Limit Values			Unit	Notes
		min.	typ.	max.		
DCL_2000 Clock Period	t _{DCP}		325		ns	DCL_2000 = 3072 kHz
			162		ns	DCL_2000 = 6144 kHz
			81		ns	DCL_2000 = 12288 kHz
DCL_2000 Duty Cycle	t _{DDC}	48		52	%	

Note: Usually DSP-clock is generated internally by the internal PLL, in a frequency of 61.44 MHz. If on the other hand a lower frequency clock is provided via CLK_DSP input pin, the selected frequency of DCL_2000 should not exceed the frequency of DSP-clock-frequency / 4 (DSP clock frequency divided by 4), in order to guarantee a proper operation of the DELIC.

Electrical Characteristics and Timing Diagrams

8.6.7 LNC0..3 (Local Network Controller) Interface Timing

Table 82 LNC0..3 Interface Timing

Parameter	Symbol	Limit Values			Unit	Notes
		min.	typ.	max.		
LRXD0..3 setup time before LCLK0..3 falling/rising edge	t_{LSL}	10			ns	
LRXD0..3 hold time after LCLK0..3 falling/rising edge	t_{LHL}	14			ns	
LCxD0..3 setup time before LCLK0..3 falling/rising edge	t_{CSL}	10			ns	
LCxD0..3 hold time after LCLK0..3 falling/rising edge	t_{CHL}	10			ns	
LTxD0..3 delay after LCLK0..3 rising edge	t_{TDR}			24	ns	LTxD0..3
LTxD0..3 float after LCLK0..3 rising edge	t_{TFR}			20	ns	
LTSC0..3 delay after LCLK0..3 rising edge	t_{SCR}			23	ns	

Electrical Characteristics and Timing Diagrams

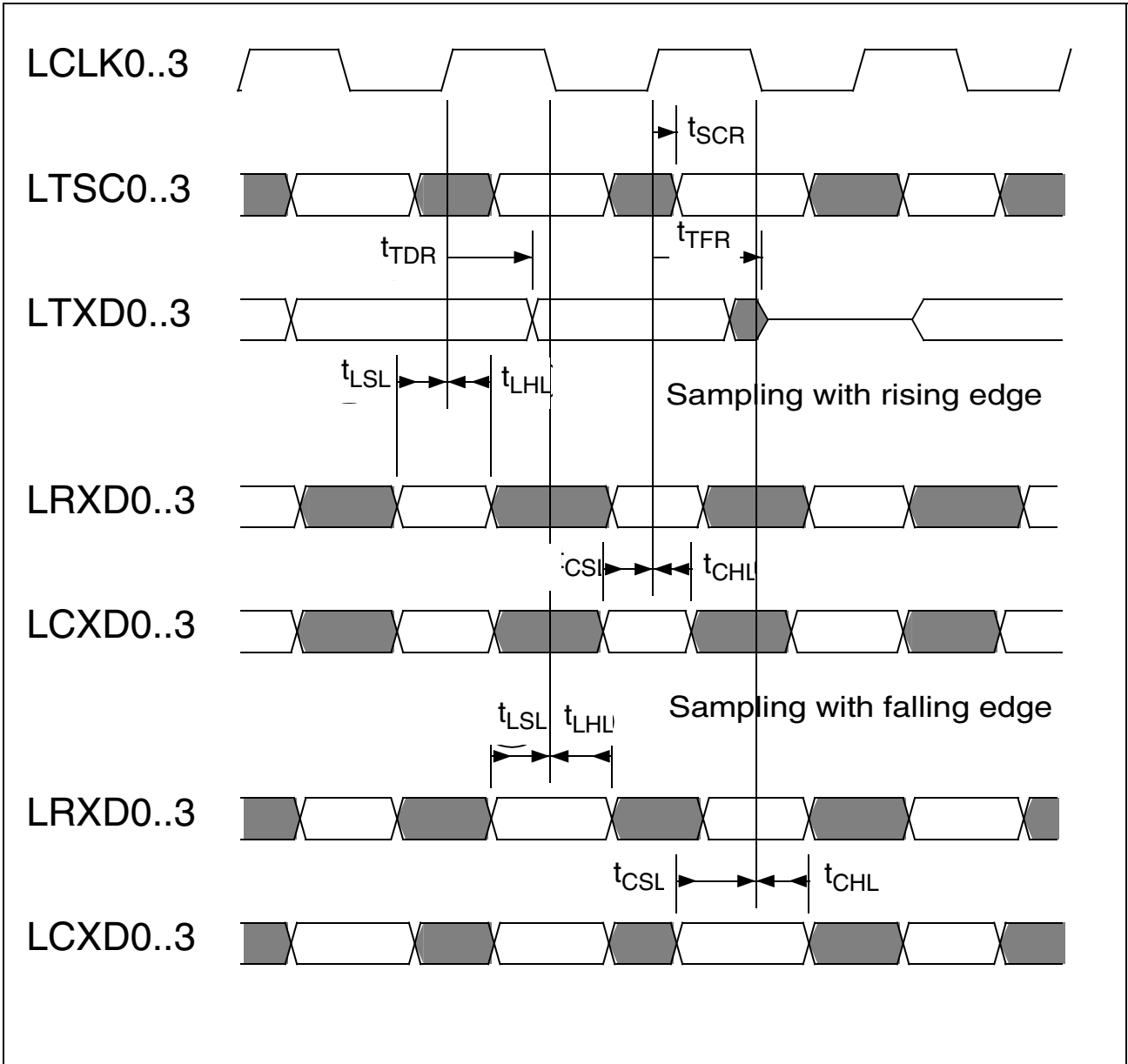

Figure 83 LNC0..3 (Local Network Controller) Interface Timing

Electrical Characteristics and Timing Diagrams

Table 83 LCLK0..3 Timing in Output Mode

Parameter	Symbol	Limit Values			Unit	Notes
		min.	typ.	max.		
LCLK0..3 Clock Period	t_{LCP}		488		ns	LCLK0..3 = 2048 kHz
			244		ns	LCLK0..3 = 4096 kHz
			122		ns	LCLK0..3 = 8192 kHz
			61		ns	LCLK0..3 = 16384 kHz
LCLK0..3 Duty Cycle in output mode		48		52	%	

Note: LCLK0..3 are generated with a 50% duty cycle. Even though all LCLKs (0, 1, 2, 3) might be operated in all possible frequencies, the frequency of each one of these clocks should be configured in accordance with the GHDLCU operating mode. For more details see section 6.2.6.2 “GHDLC Channel Mode Register”. Usually DSP-clock is generated internally by the internal PLL, in a frequency of 61.44 MHz. If on the other hand a lower frequency clock is provided via CLK_DSP input pin, the frequency of LCLK0..3 (input or output) should not exceed the frequency of DSP-clock-frequency / 4 (DSP clock frequency divided by 4), in order to guarantee a proper operation of the DELIC.

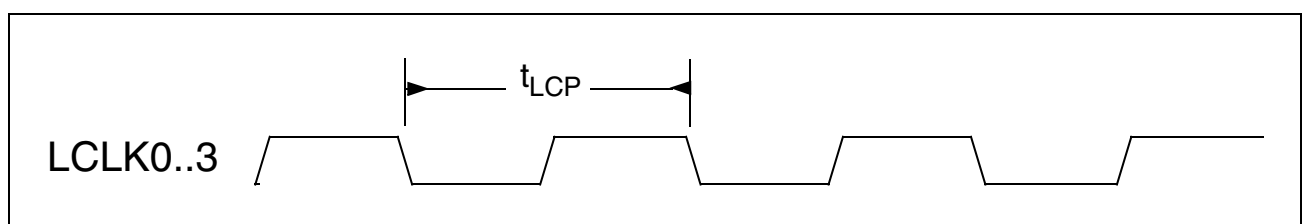

Figure 84 LCLK0..3 Timing in Output Mode

Table 84 LCLK0..3 Timing in Input Mode

Parameter	Symbol	Limit Values			Unit	Notes
		min.	typ.	max.		
LCLK0..3 Minimum High Pulse	t_{LMH}	22			ns	In Input Mode
LCLK0..3 Minimum Low Pulse	t_{LML}	22			ns	In Input Mode

Electrical Characteristics and Timing Diagrams

Note: The frequency of each LCLKn pin ($n = 0, 1, 2, 3$) should not exceed the maximum frequency, defined according to the GHDLCU operating mode. For more details see section 6.2.6.2 “GHDLC Channel Mode Register”. The Minimum pulse width (high or low) of LCLK0..3 depends on the DSP clock frequency. Usually this clock is generated internally by the internal PLL, in a frequency of 61.44 MHz. In this case the values in the table above are valid. If a lower frequency for DSP-clock is provided via CLK_DSP input pin, and PDC is used as input, the low/high pulse width of PDC should not be smaller than $1.5 \times$ DSP-clock-cycle (DSP-clock-cycle is the cycle time of the provided DSP clock). Usually DSP-clock is generated internally by the internal PLL, in a frequency of 61.44 MHz. If on the other hand a lower frequency clock is provided via CLK_DSP input pin, the frequency of LCLK0..3 (input or output) should not exceed the frequency of DSP-clock-frequency / 4 (DSP clock frequency divided by 4), in order to guarantee a proper operation of the DELIC.

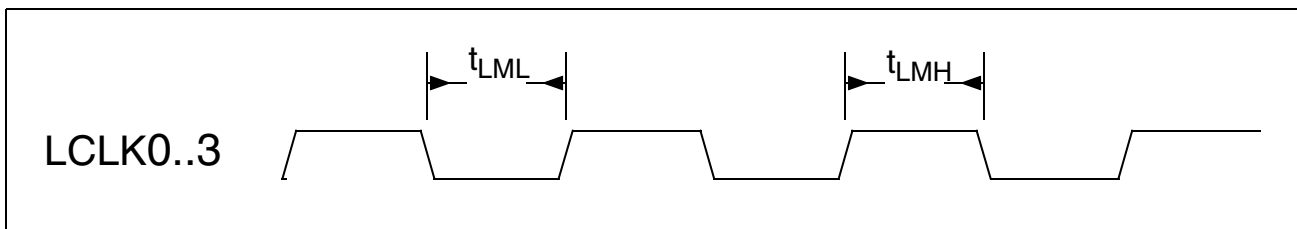

Figure 85 LCLK0..3 Timing in Input Mode

Table 85 CLK_DSP Input Clock Timing

Parameter	Symbol	Limit Values			Unit	Notes
		min.	typ.	max.		
CLK_DSP Maximum Frequency	t_{CMF}			61.44	MHz	
CLK_DSP Duty-Cycle	t_{CDD}	48		52	%	

Note: Usually CLK_DSP is not used. If it is, special care should be taken regarding its duty-cycle. The duty-cycle of CLK_DSP should be very close to 50%, since this clock is also used for the clock-generation for the OAK (ϕ_1, ϕ_2).

Electrical Characteristics and Timing Diagrams

8.6.8 JTAG and Emulation Interface Timing

Table 86 Test Interface Timing

Parameter	Symbol	Limit Values			Unit	Notes
		min.	typ.	max.		
Test Clock (JTCK) Period	t_{TCJ}	160			ns	
Test Clock (JTCK) Period Low	t_{CJL}	80			ns	
Test Clock (JTCK) Period High	t_{CJH}	80			ns	
TMS Set-up time before JTCK Rising Edge	t_{SUJ}	30			ns	
TMS Hold time after JTCK Rising Edge	t_{HJR}	30			ns	
TDI Set-up time before JTCK Rising Edge	t_{DSE}	30			ns	
TDI Hold time after JTCK Rising Edge	t_{DHE}	30			ns	
TDO Delay after JTCK Falling Edge	t_{ODF}			60	ns	
Any output pin Delay after JTCK Falling Edge	t_{OPD}			60	ns	In Update-DR TAP Controller State
Any input pin setup time before JTCK rising edge	t_{IPJ}	30			ns	In Capture-DR TAP Controller State
Any input pin hold time before JTCK rising edge	t_{IAJ}	30			ns	

Electrical Characteristics and Timing Diagrams

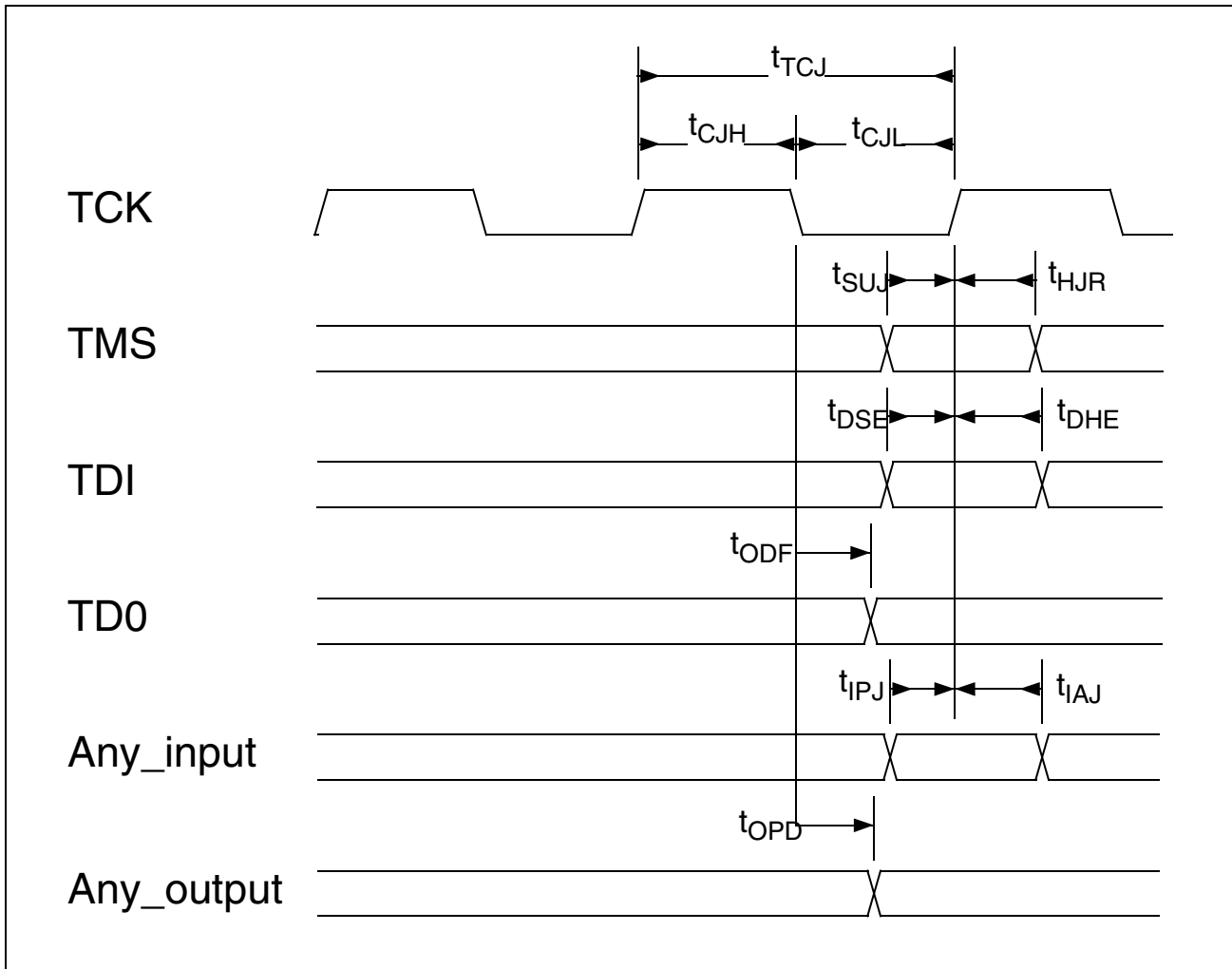

Figure 86 Test-Interface (Boundary Scan) Timing

Table 87 $\overline{\text{RESET}}$ and $\overline{\text{RESIND}}$ (Reset Indication) timing

Parameter	Symbol	Limit Values			Unit	Notes
		min.	typ.	max.		
RESET pulse width	t_{RPW}	430			ns	
RESIND pulse width	t_{RIW}	500		800	μs	
RESIND deactivation after RESET deactivation	t_{RDR}			800	μs	

Electrical Characteristics and Timing Diagrams

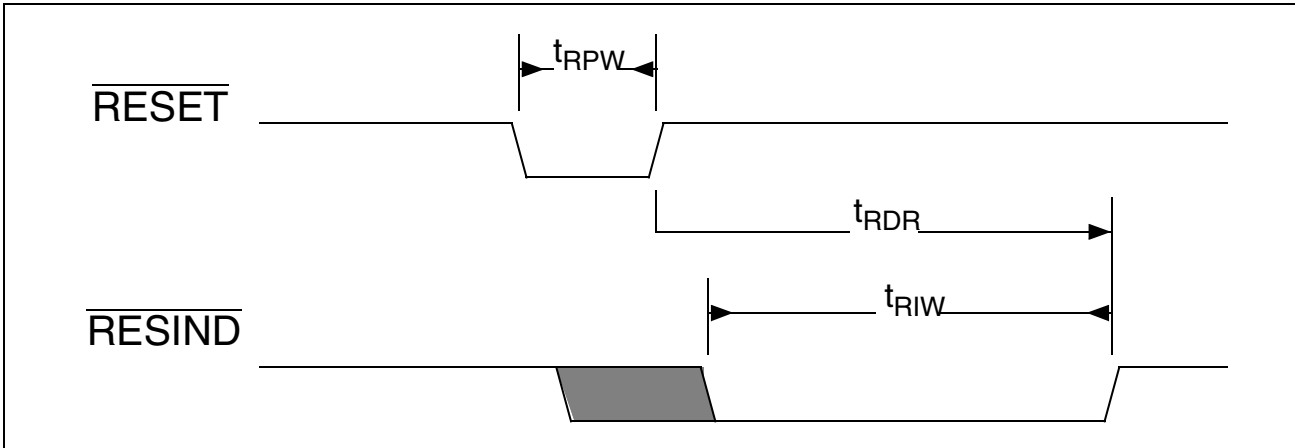

Figure 87 Reset Indication Timing

Table 88 CLOCKOUT Timing

Parameter	Symbol	Limit Values			Unit	Notes
		min.	typ.	max.		
CLKOUT Period	t_{CKP}		488		ns	CLKOUT = 2048 kHz
			244		ns	CLKOUT = 4096 kHz
			122		ns	CLKOUT = 8192 kHz
			65		ns	CLKOUT = 15360 kHz
			61		ns	CLKOUT = 16384 kHz
CLKOUT Duty-Cycle		48	50	52		

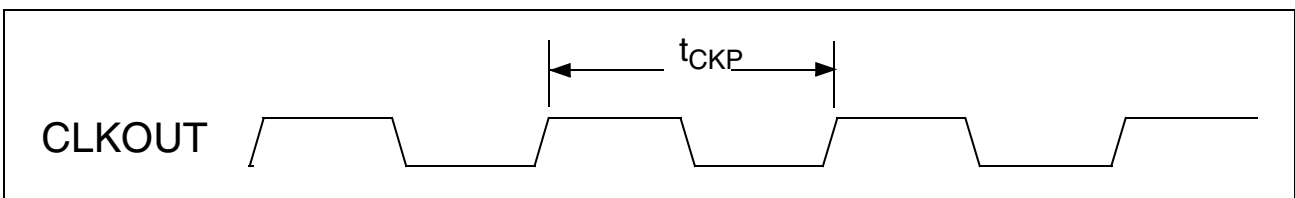

Figure 88 CLOCKOUT Timing

Table 89 L1_CLK Timing

Parameter	Symbol	Limit Values			Unit	Notes
		min.	typ.	max.		
L1_CLK Period	t_{LCP}		65		ns	L1_CLK = 15.36 MHz
			130		ns	L1_CLK = 7.68 MHz
L1_CLK Duty-Cycle		48	50	52	%	

Electrical Characteristics and Timing Diagrams

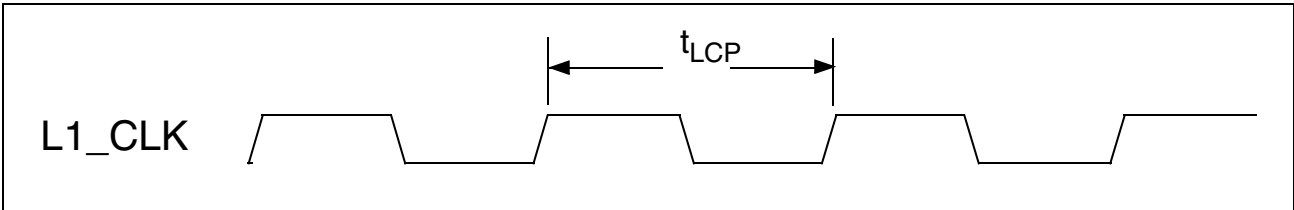

Figure 89 L1_CLK Timing

Table 90 XCLK Timing

Parameter	Symbol	Limit Values			Unit	Notes
		min.	typ.	max.		
XCLK Period ¹⁾	t_{XLP}		488		ns	XCLK = 2.048 MHz
			651		ns	XCLK = 1.536 MHz
			125		μ s	XCLK = 8 kHz
XCLK Minimum High Period	t_{XLH}	50			ns	
XCLK Minimum Low Period	t_{XLL}	50			ns	

¹⁾ XCLK is always an input. The frequencies, which are specified in the table above, should be provided by the user. When XCLK is used as a reference clock for the internal DCXO-PLL, one of these specified frequencies must be used, to guarantee proper work of the DELIC.

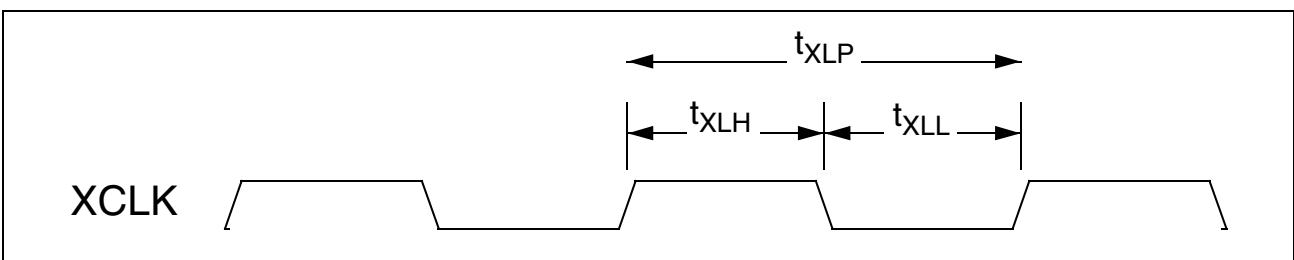

Figure 90 XCLK Timing

Electrical Characteristics and Timing Diagrams

Table 91 REFCLK Timing

Parameter	Symbol	Limit Values			Unit	Notes
		min.	typ.	max.		
REFCLK Period ¹⁾	t_{RFP}		1.953		μs	REFCLK = 512 kHz
			125		μs	REFCLK = 8 kHz
REFCLK Minimum High Period	t_{RFH}	50			ns	
REFCLK Minimum Low Period	t_{RFL}	50			ns	

¹⁾ REFCLK may be used either as an input or as an output. When used as an input, the frequencies, which are specified in the table above, should be provided by the user. When REFCLK is used as a reference clock for the internal DCXO-PLL, one of these specified frequencies must be used, to guarantee proper work of the DELIC.

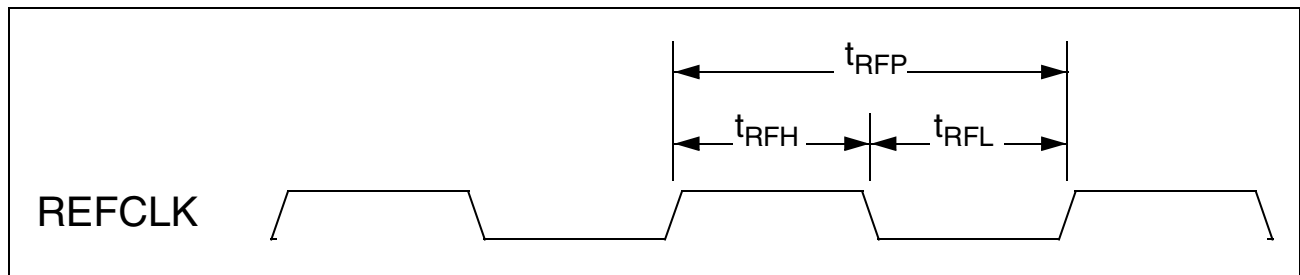

Figure 91 REFCLK Timing

9 Application Hints

9.1 DELIC Connection to External Microprocessors

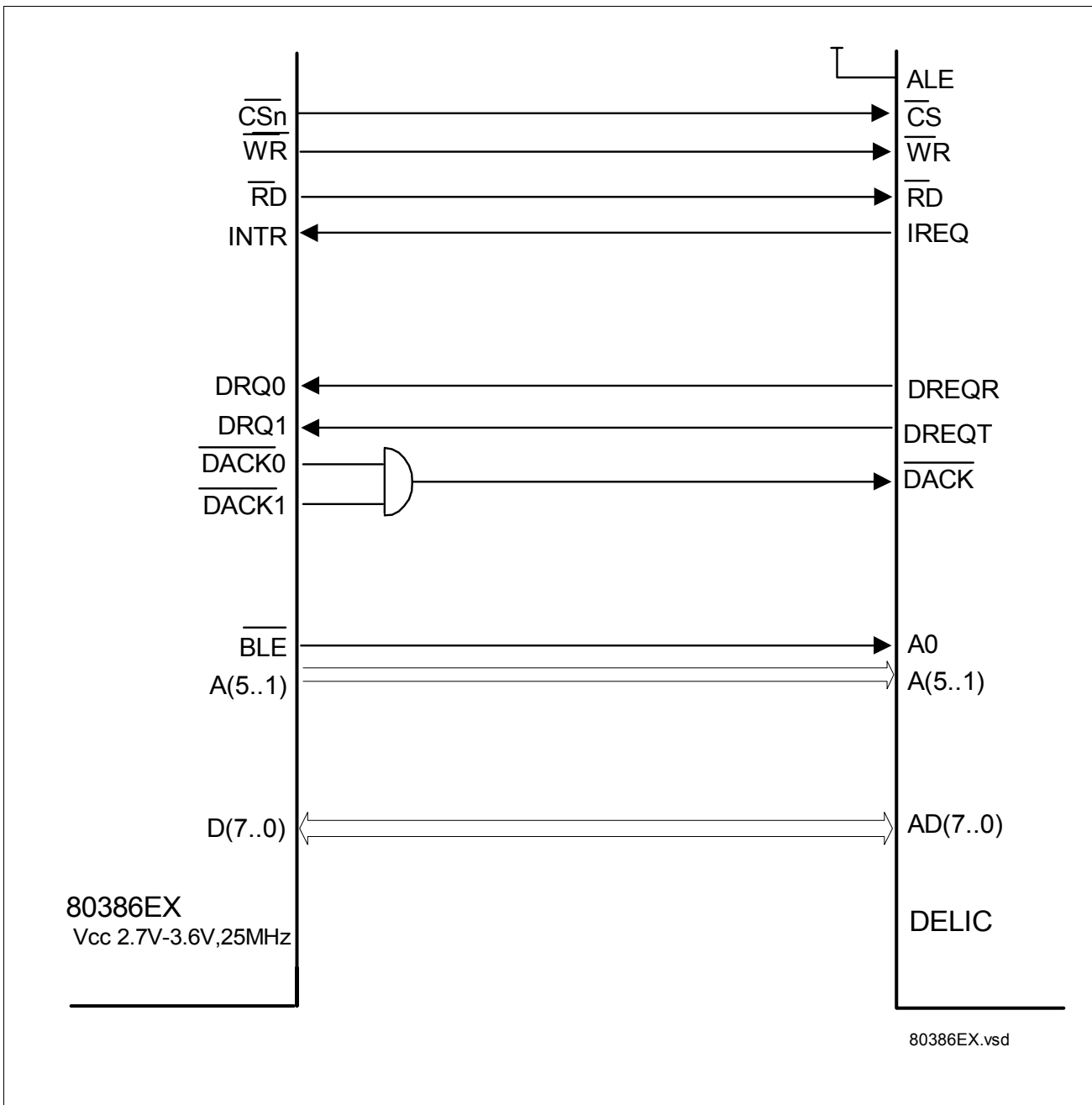

Figure 92 DELIC Connection to Intel 80386EX (Demuxed Configuration)

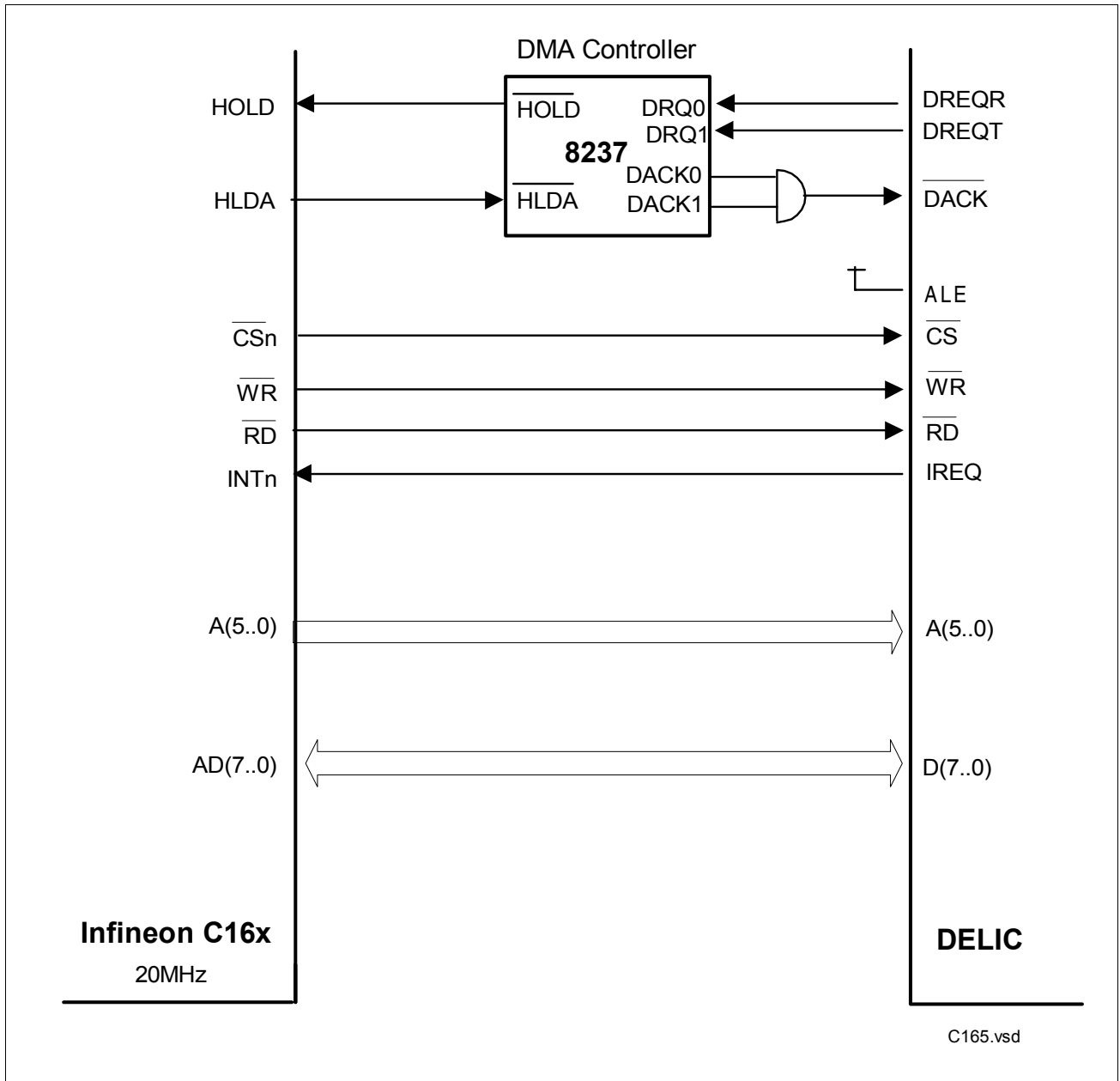

Figure 93 DELIC Connection to Infineon C165 (Demuxed Configuration)

9.2 DELIC Worksheets

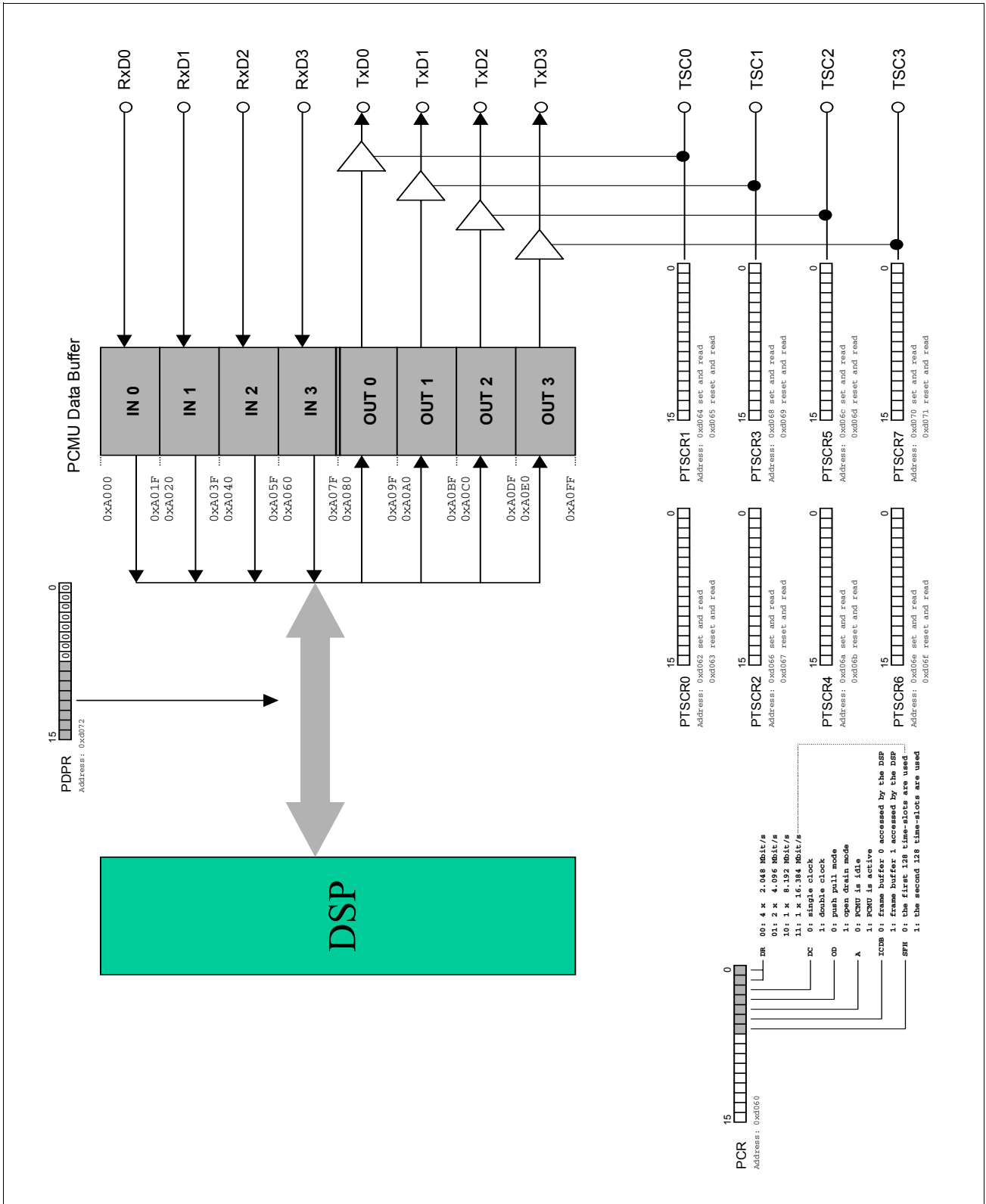

Figure 94 DELIC-LC PCM Unit Mode 0 (4 Ports with 2 MBit/s)

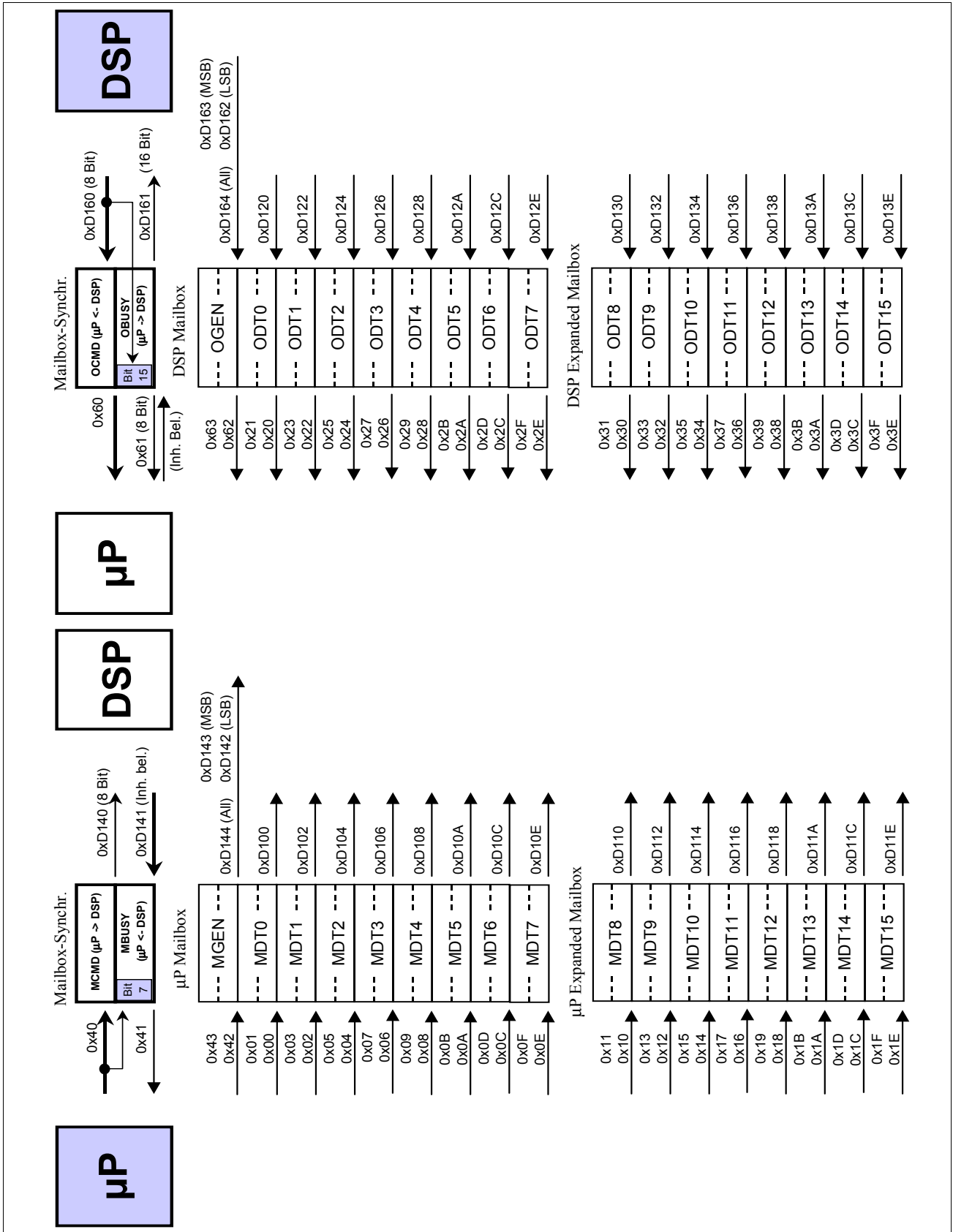

Figure 95 Command/ Indication Handshake of General Mailbox

9.3 PCM Output Driver Anomaly

When applying the PCM outputs in a bus configuration with pull-ups to 5 V the output drivers of the DELIC have an irregular behavior.

As can be seen from the illustration below, the PCM output drivers TXDn (n=0..3) continue to drive 'High' level even outside the time slot enabled by TSC. This error occurs only if the last bit in the time slot is a '1'. In this case no problem occurs if another PCM port drives a '0' in the neighbor time slot. In other words this means that the output driver drives 3.3 V for a certain time against the 5 V pull-up. As soon as a neighbor time slot is driven to '0' by another port the DELIC stops driving immediately.

As the occurring current is no problem for the DELIC, this behavior is uncritical.

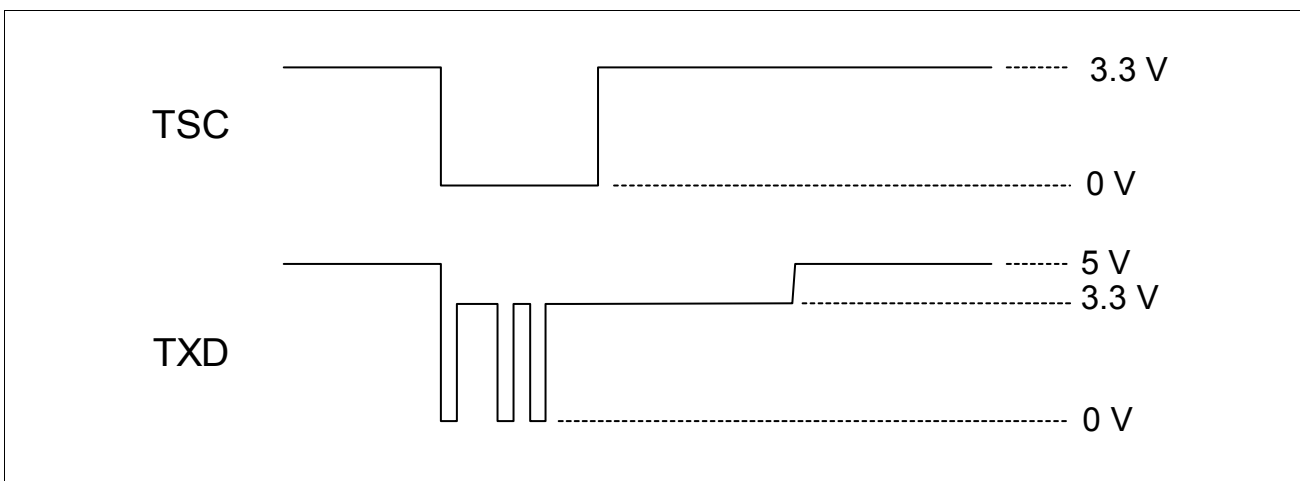

Figure 96 Behavior of Output Driver if Last Bit is '1'

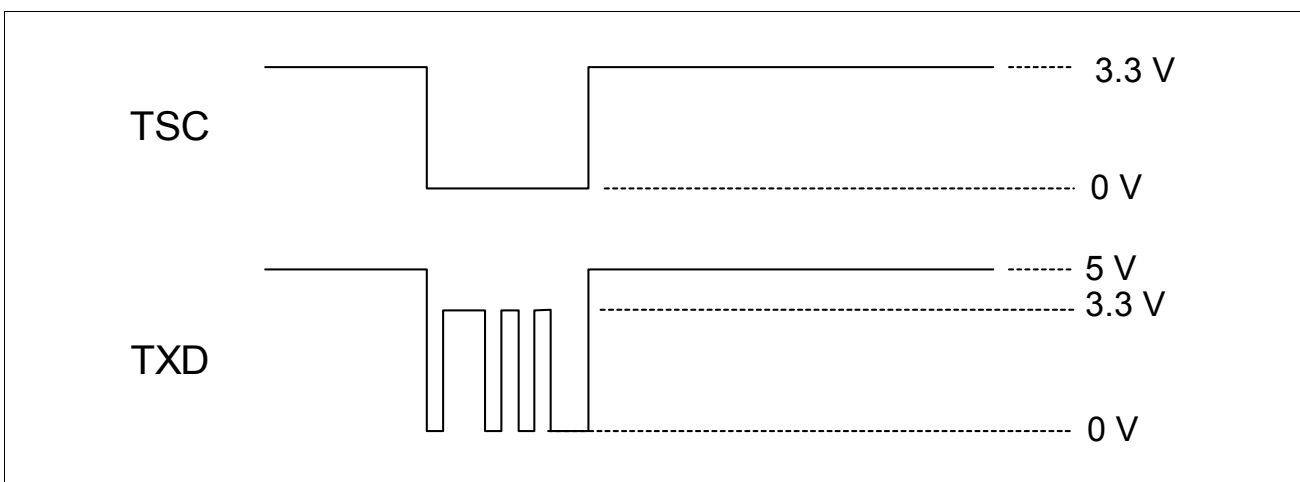

Figure 97 Behavior of Output Driver if Last Bit is '0'

9.4 Reset Behaviour

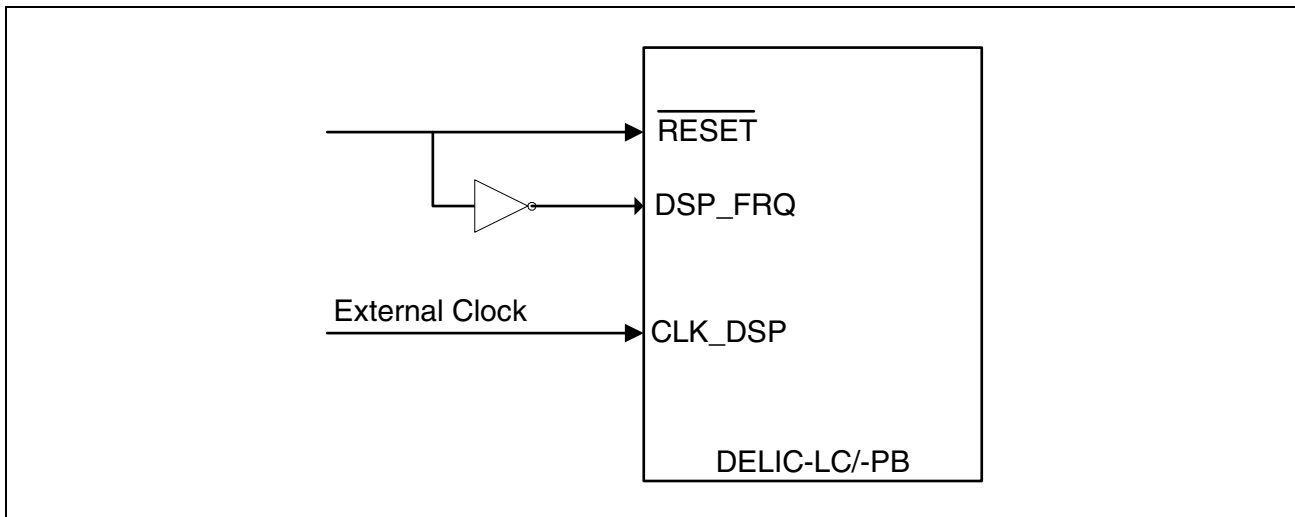

Figure 98 Guaranteed Reset Behaviour

If the DELIC DSP uses the internal 61.44 MHz clock, the reset value of the DELIC registers can only be guaranteed 200 ns after the **rising edge** of the reset signal.

If an external DSP clock is used, the reset behaviour is normal, e.g. the reset values are valid after the **falling edge** of the reset signal.

In order to guaranty the reset behaviour of the DELIC in any case, the external circuitry as shown in **Figure 98** is recommended. During reset, the DSP is clocked externally. When reset is deactivated the internal DSP clock is used.

Note: The frequency of the external clock is not important. The higher the frequency the faster the reset values are valid. A clock frequency in the range of several MHz (e.g. 4 MHz) is recommended.

10 Glossary

AHV-SLIC PEB 4165	High voltage part of SLIC
CMOS	Complementary Metal Oxide Semiconductor
CO	Central Office
CODEC	Coder Decoder
DC	Direct Current
DECT	Digital European Cordless Telecommunication
DELIC	DSP Embedded Line and Port Interface Controller (PEB 20570, PEB 20571)
DSL	Digital Subscriber Line
DSP	Digital signal processor
HDLC	High-level Data Link Control
IEEE	Institute of Electrical and Electronic Engineers
INFO	U- and S-interface signal as specified by ANSI/ETSI
I/O	Input/Output
IOM-2	ISDN-Oriented Modular 2nd generation
IOM-2000	Proprietary ISDN interface for S/T and U _{PN}
ISDN	Integrated services Digital Network
ITU	International Telecommunications Union
μP	Micro Processor
OCTAT-P	OCTAI Transceiver for U _{PN} -Interfaces (PEB 2096)
LT-S	Line Termination-Subscriber
LT-T	Line Termination-Trunk
PLL	Phase-Locked Loop
PBX	Private Branch Exchange
AFE	4-channel analog front end of U-transceiver (PEB24902)
DFE	4-channel digital front end of U-transceiver (PEB24911)
QUAT-S	QUAdrupleTransceiver for S/T-Interface (PEB 2084)
SLICOFI-2 PEB 3265	Dual channel CODEC + low voltage part of SLIC



SOCRATES	SHDSL One Chip Rate Adaptive Transceiver with Embedded Start Up
S/T	Two-wire pair ISDN interface
TAP	Test Access Port

11 Index

A

Applications 7

B

Block Diagram 70

Block Diagram of the DELIC-LC 3, 125

Boot Strap Pin Setting 130

D

Differences DELIC-LC - DELIC-PB 69

F

Features

DELIC-LC 4

DELIC-PB 4

I

Interfaces

IOM-2000 41

Overview 40

Interrupts 66

IOM-2000

Command and Status Interface 72

IOM-2000 Frame Structure 42

J

JTAG Test Interface 67

L

Logic Symbol 6

P

Pin Definitions 12, 24

Pin Diagram 10

Principle Block Diagram of the DELIC-PB
3

S

S/T State Machine 54

Strap Pin Definitions 38

T

TRANSIU

Initialization 71

Overview of Features 71

U

U_{PN} line interface

Frame structure 76

V

VIP

Initialization 72

Infineon goes for Business Excellence

“Business excellence means intelligent approaches and clearly defined processes, which are both constantly under review and ultimately lead to good operating results.

Better operating results and business excellence mean less idleness and wastefulness for all of us, more professional success, more accurate information, a better overview and, thereby, less frustration and more satisfaction.”

Dr. Ulrich Schumacher

<http://www.infineon.com>