

YCL

PG243001/243002

4 Channels Gigabit Transformers

Feature

- ◆ Designed to meet IR 235°C Peak Requirement.
- ◆ Primary inductance 350μH min. with 8mA DC bias.
- ◆ Designed to meet IEEE802.3ab Requirement.

Specifications @25°C

Parameter	Conditions	Min.	Typ	Max.	Unit
Turn ratio			1CT:1CT		
Lp (Note 1)	With 8mA _{dc}	350			μH
Insertion loss	@1-100MHz			-1.0	dB
Return loss	@1-30MHz	16.0			dB
	@30-60MHz	Note 2			dB
	@60-80MHz	10			dB
Crosstalk	@30MHz		-40.0		dB
	@60MHz		-38.0		dB
	@100MHz		-33.0		dB
CDMRR	@0.1-32MHz		-42.0		dB
	@32-62MHz		-37.0		dB
	@62-100MHz		-33.0		dB
CCMRR	@0.1-100MHz		-30.0		dB
Voltage Isolation		1500			V _{rms}

Note 1: over operating temperature 0-70°C

Note 2 : Greater than 16-20 log(f/30 MHz)dB

Schematic

PG243001

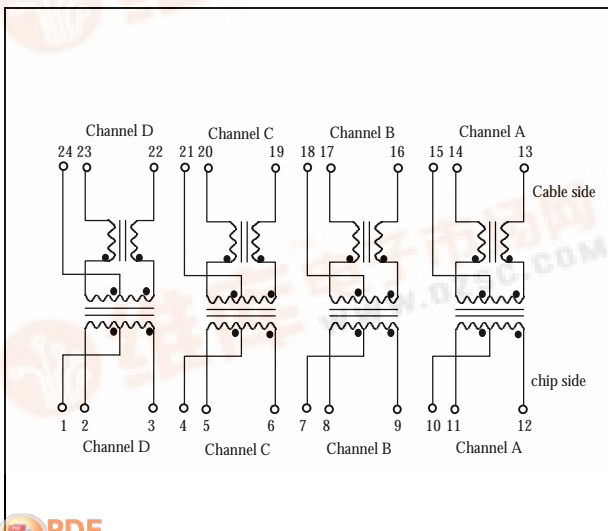

PG243002

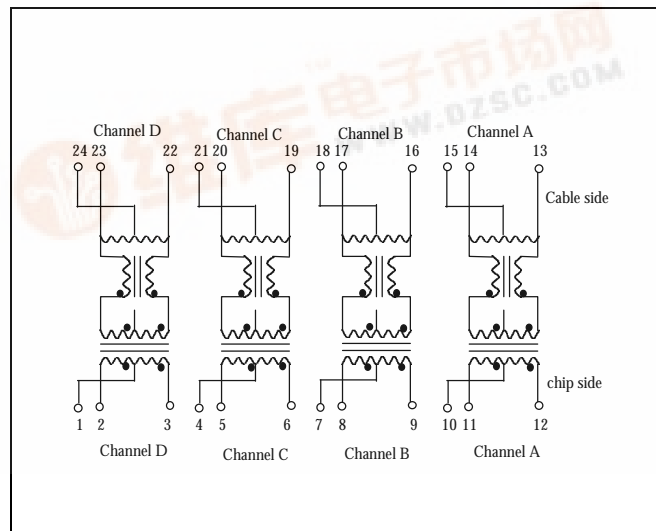

Dimension

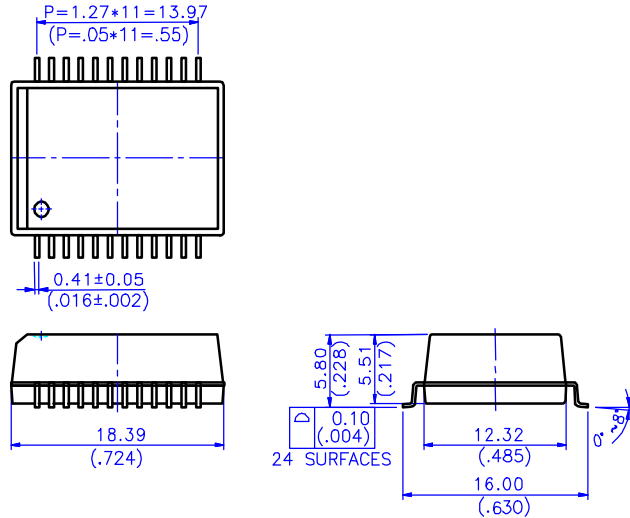

Reflow Soldering Profile

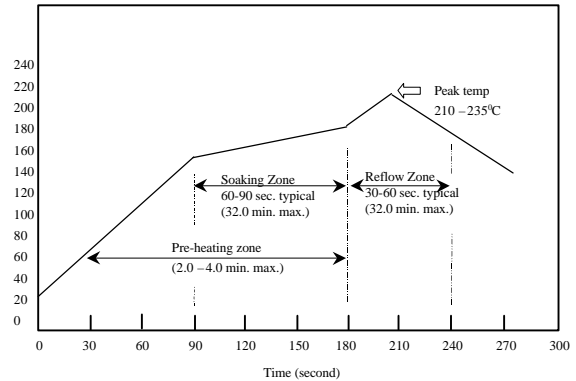

Unless otherwise specified, all tolerances are mm(inch)±0.25(0.010)

Tape & Reel Applications

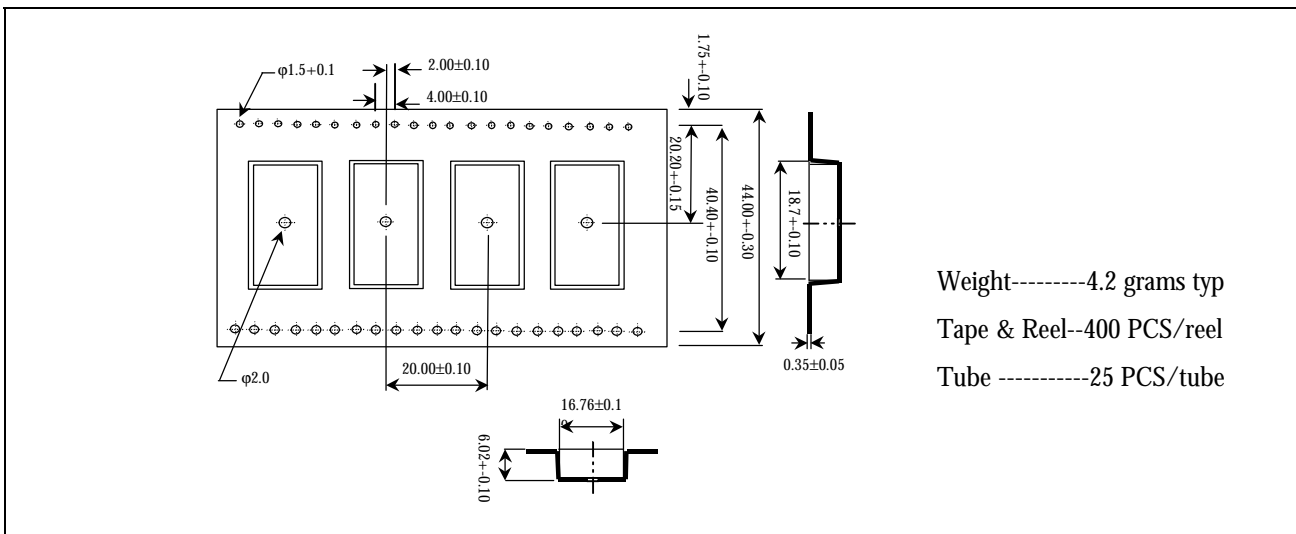

For More Information

Headquarters

Taiwan :
Tel: 886-7-7458587
Fax: 886-7-7459120

Asia

Taiwan :
Tel: 886-2-27962878
Fax: 886-2-27912635
Email:dennis@ycl.com.tw

USA

Santa Clara :
Tel : (408)727-3827
Fax: (408)727-3857
Email: hegwood@ycl.com.tw

EUROPE

Paris :
Tel : (33)247443901
Fax : (33)247447806
Email:mab007@calva.net
Email:brbsarl@aol.com