



M/A-COM

Avionics Pulsed Power Transistor - 550 Watts, 1030-1090 MHz, 10μs Pulse, 1% Duty



Features

- Designed for Short Pulse IFF Applications
- NPN Silicon Microwave Power Transistor
- Common Base Configuration
- Broadband Class C Operation
- High Efficiency Interdigitated Geometry
- Diffused Emitter Ballasting Resistors
- Gold Metalization System
- Internal Input and Output Impedance Matching
- Hermetic Metal/Ceramic Package

Description

M/A-COM's PH1090-550S is a silicon bipolar NPN transistor intended for use in L-band, 1.2 - 1.4 GHz avionics equipment such as IFF, mode-S and TCAS systems. Designed for common-base, class C broadband pulsed power applications, the PH1090-550S delivers 7.5 dB of gain at 550 watts of output power when operating with short pulse length (10μs), at 1 percent duty cycle. The transistor is housed in a 2-lead, rectangular metal-ceramic flange package, with internal input and output impedance matching networks. Diffused emitter ballast resistors and gold metalization assure ruggedness and long-term reliability.

Outline Drawing¹

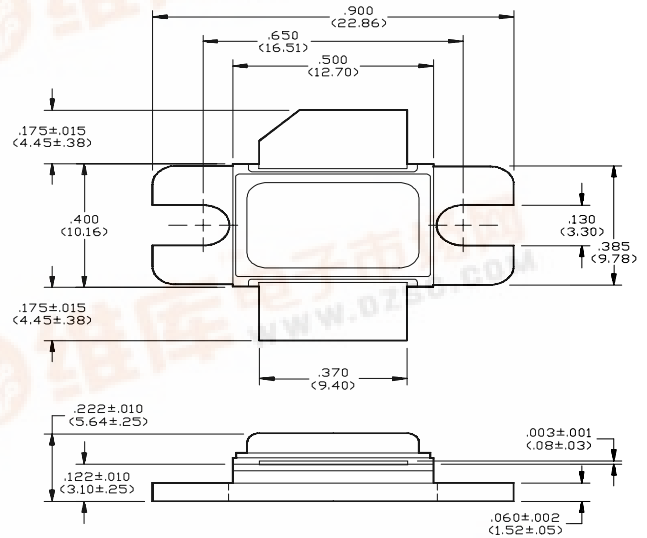

Notes: (unless otherwise specified)

1. Tolerances are: inches ± .005" (millimeters ± 0.13mm)

Broadband Test Fixture Impedance

F (MHz)	Z _{IF} (Ω)	Z _{OF} (Ω)
1030	4.0 - j3.5	1.4 - j1.6
1090	3.6 - j2.7	1.1 - j1.9

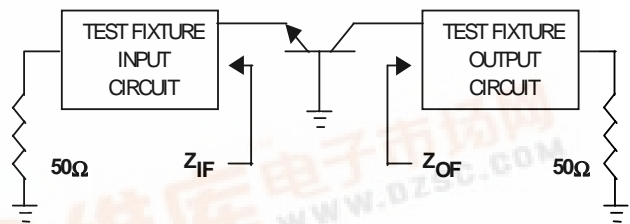

Absolute Maximum Rating at 25°C

Parameter	Symbol	Rating	Units
Collector-Emitter Voltage	V _{CES}	80	V
Emitter-Base Voltage	V _{EBO}	3.0	V
Collector Current (Peak)	I _C	28	A
Total Power Dissipation @ +25°C	P _{TOT}	1800	W
Storage Temperature	T _{stg}	-65 to +200	°C
Junction Temperature	T _j	200	°C

Electrical Specifications at 25°C

Symbol	Parameter	Test Conditions	Min	Max	Units
BV _{CES}	Collector-Emitter Breakdown	I _C =250mA	80	-	V
I _{CES}	Collector-Emitter Leakage	V _{CE} =45 V	-	25	mA
R _{TH(JC)}	Thermal Resistance	V _{CC} =50 V, P _{out} =550 W, f=1090 MHz	-	0.05	°C/W
P _{in}	Input Power	V _{CC} =50 V, P _{out} =550 W, f=1090 MHz	-	100	W
G _P	Power Gain	V _{CC} =50 V, P _{out} =550 W, f=1090 MHz	7.5	-	dB
η	Collector Efficiency	V _{CC} =50 V, P _{out} =550 W, f=1090 MHz	55	-	%
R _L	Input Return Loss	V _{CC} =50 V, P _{out} =550 W, f=1090 MHz	9	-	dB
VSWR-T	Load Mismatch Tolerance	V _{CC} =50 V, P _{out} =550 W, f=1090 MHz	-	10:1	-
VSWR-S	Load Mismatch Stability	V _{CC} =50 V, P _{out} =550 W, f=1090 MHz	-	1.5:1	-

Test Fixture Electrical Schematic

Top View

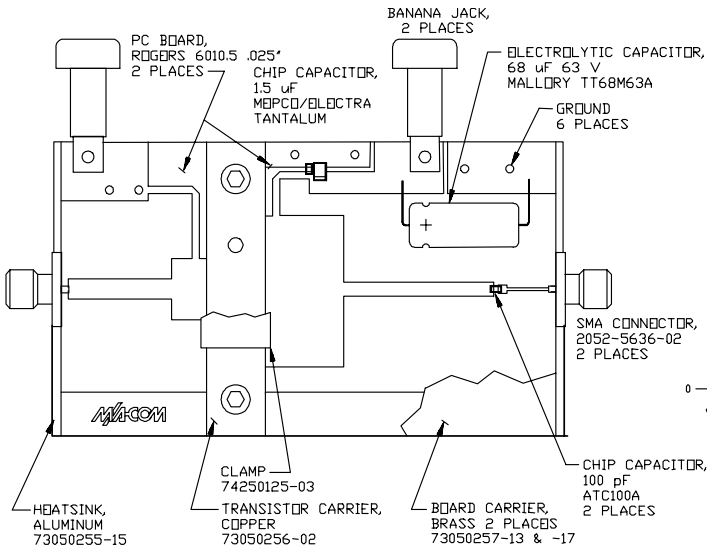

Circuit Dimensions

