



Radar Pulsed Power Transistor, 300 Watts, 1.20-1.40 GHz, 150 μ S Pulse, 10% Duty

12/06/01

Rev. 0

PH1214-300M

Features

- NPN Silicon Microwave Power Transistor
- Common Base Configuration
- Broadband Class C Operation
- High Efficiency Interdigitated Geometry
- Gold Metalization System
- Internal Input and Output Impedance Matching
- Hermetic Metal/Ceramic Package

Outline Drawing

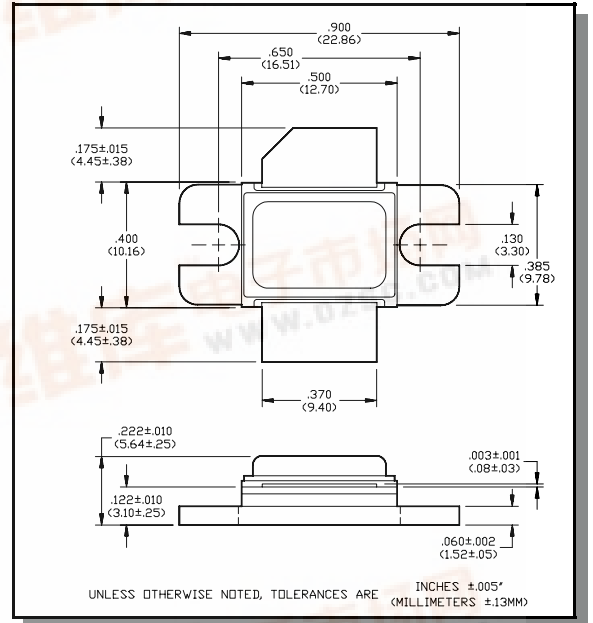

Absolute Maximum Ratings @ 25 °C

Parameter	Symbol	Rating	Units
Collector-Emitter Voltage	V_{CES}	90	V
Emitter-Base Voltage	V_{EBO}	3.0	V
Collector Current (Peak)	I_C	21.0	A
Total Power Dissipation @ +45 °C	P_{TOT}	620	W
Storage Temperature	T_{STG}	-65 to +200	°C
Junction Temperature	T_J	200	°C

Electrical Characteristics @ 25 °C

Parameter	Symbol	Min.	Max.	Units	Test Conditions
Collector-Emitter Breakdown Voltage	BV_{CES}	90	-	V	$I_C=80$ mA
Collector-Emitter Leakage Current	I_{CES}	-	10	mA	$V_{CE}=40$ V
Thermal Resistance	$R_{TH(JC)}$	-	.25	°C/W	$V_{CC}=40$ V, $P_{in} = 40$ W, Freq= 1.2, 1.3 and 1.4 GHz
Output Power	P_O	300	-	W	$V_{CC}=40$ V, $P_{in} = 40$ W, Freq= 1.2, 1.3 and 1.4 GHz
Power Gain	G_P	8.75	-	dB	$V_{CC}=40$ V, $P_{in} = 40$ W, Freq= 1.2, 1.3 and 1.4 GHz
Collector Efficiency	η	50	-	%	$V_{CC}=40$ V, $P_{in} = 40$ W, Freq= 1.2, 1.3 and 1.4 GHz
Input Return Loss	RL	10	-	dB	$V_{CC}=40$ V, $P_{in} = 40$ W, Freq= 1.2, 1.3 and 1.4 GHz
Load Mismatch Tolerance	VSWR-T	-	2:1	-	$V_{CC}=40$ V, $P_{in} = 40$ W, Freq= 1.2, 1.3 and 1.4 GHz
Load Mismatch Stability	VSWR-S	-	1.5:1	-	$V_{CC}=40$ V, $P_{in} = 40$ W, Freq= 1.2, 1.3 and 1.4 GHz



Sample Test Data

(Broadband test fixture matched to 50 Ω.)

Freq. (GHz)	Pin (W)	Pout (W)	Gain (dB)	ΔGain (dB)	Eff. (%)	Ic (A)	Droop (dB)	RL (dB)	P1dB Overdrive					VSWR-S		
									Pout (W)	Δ Po (dB)	Gain (dB)	Droop (dB)	Eff. (%)	1.5:1	2:1	2.5:1
1.2	40	406	10.06	0.82	63.2	16.1	0.1	18	451	0.46	9.52	0.38	59.8	S	S	S
1.3	40	355	9.48		59.3	15	0.04	15	412	0.65	9.12	0.32	58.2	S	S	S
1.4	40	335.8	9.24		58.4	14.4	0.06	16	378	0.51	8.75	0.35	56	S	S	S

Note: ΔPo(dB) is the difference between Pout at 1dB overdrive and Pout at Pin = 40W.

Power Output Curves

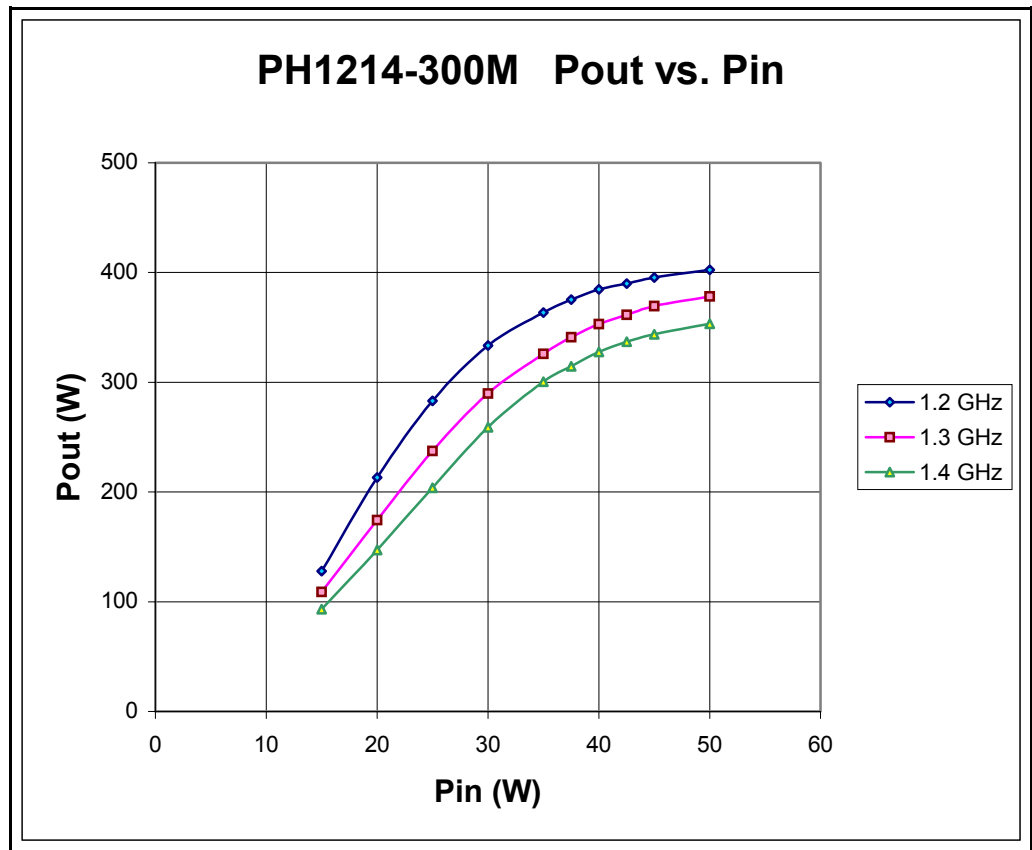

Test Fixture Impedances

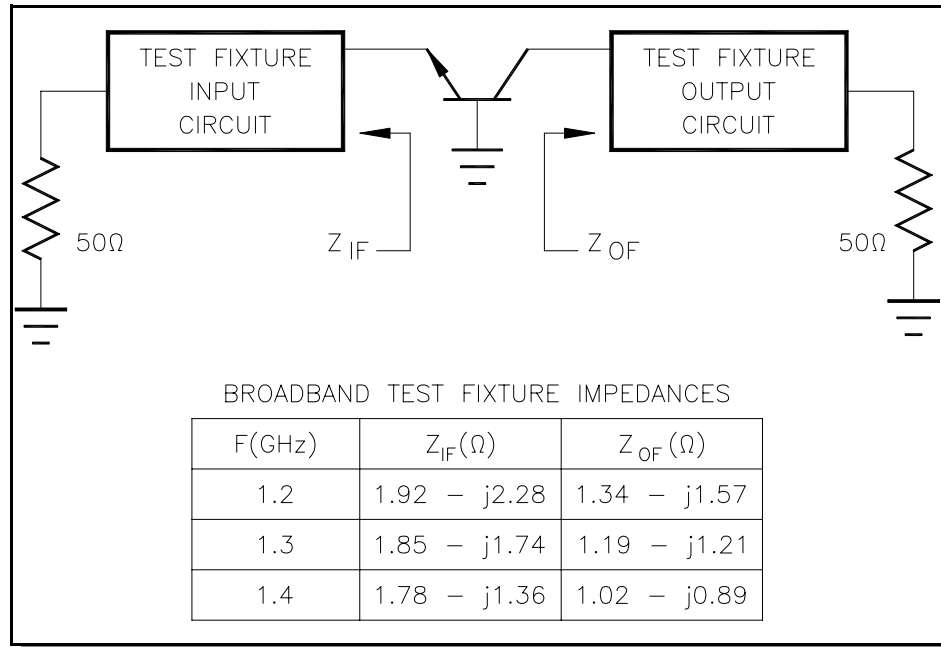

Test Fixture Circuit Dimensions

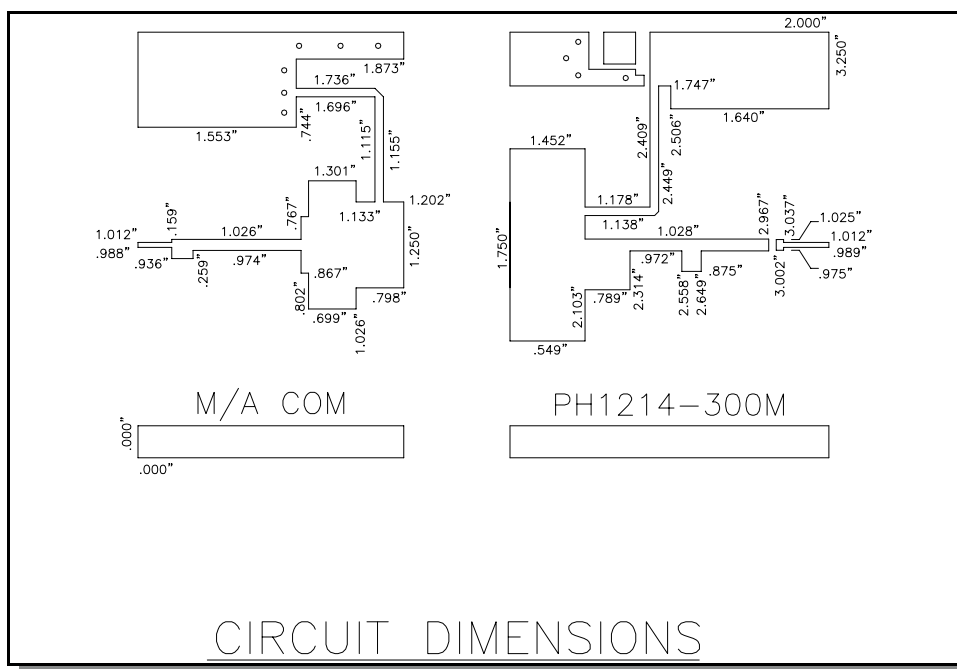

Test Fixture Assembly

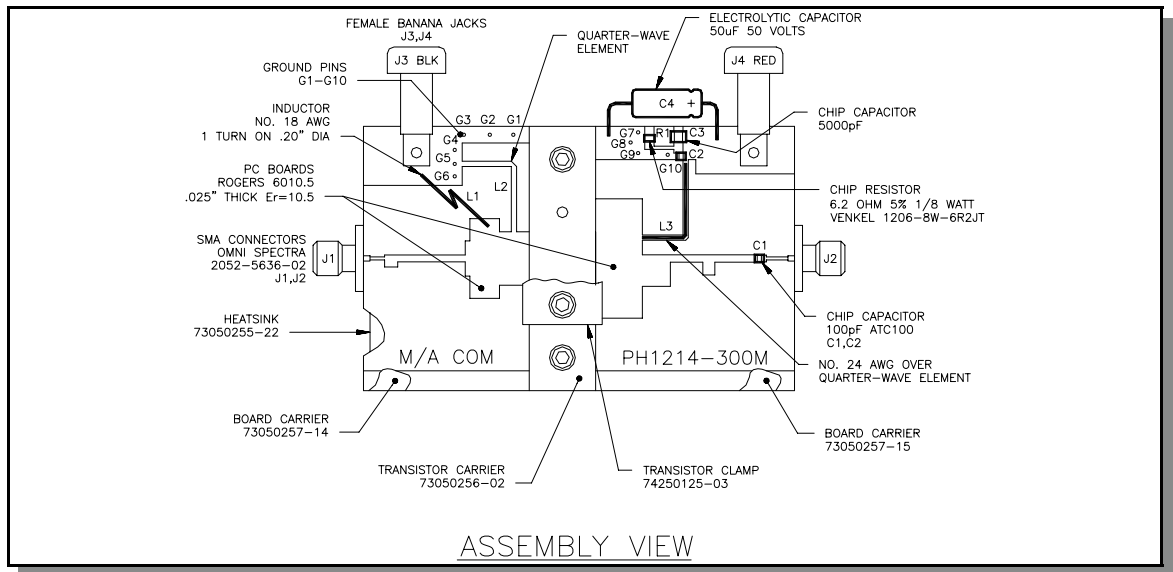

Specifications subject to change without notice.

- North America: Tel. (800) 366-2266
- Asia/Pacific: Tel.+81-44-844-8296, Fax +81-44-844-8298
- Europe: Tel. +44 (1344) 869 595, Fax+44 (1344) 300 020

Visit www.macom.com for additional data sheets and product information.