



Radar Pulsed Power Transistor, 55W, 1.0ms Pulse, 10% Duty 1.2 - 1.4 GHz

PH1214-55EL

V2.00

Features

- NPN Silicon Microwave Power Transistor
- Common Base Configuration
- Broadband Class C Operation
- Matrix Geometry
- Diffused Emitter Ballasting Resistors
- Gold Metalization System
- Internal Input Impedance Matching
- Hermetic Metal/Ceramic Package

Absolute Maximum Ratings at 25°C

Parameter	Symbol	Rating	Units
Collector-Emitter Voltage	V_{CES}	58	V
Emitter-Base Voltage	V_{EBO}	3.0	V
Collector Current (Peak)	I_C	7.0	A
Total Power Dissipation	P_{TOT}	100	W
Junction Temperature	T_J	200	°C
Storage Temperature	T_{STG}	-65 to +200	°C

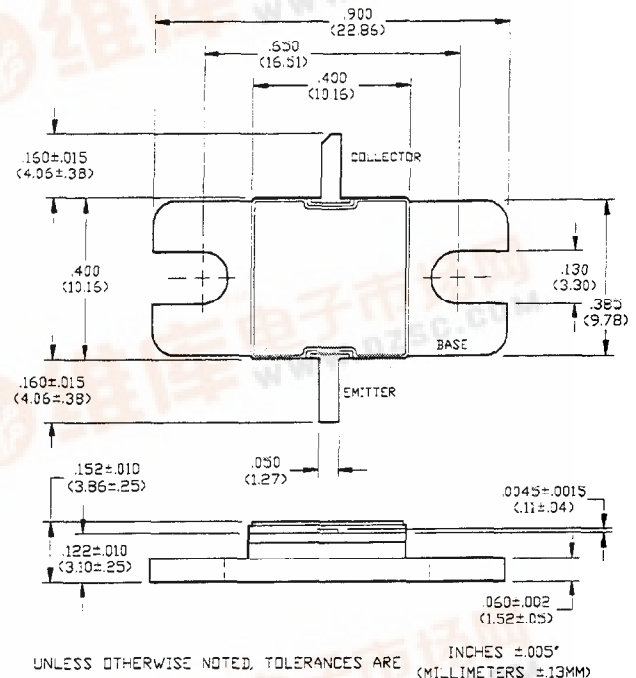

Electrical Characteristics at 25°C

Parameter	Symbol	Min	Max	Units	Test Conditions
Collector-Emitter Breakdown Voltage	BV_{CES}	58	-	V	$I_C=120$ mA
Collector-Emitter Leakage Current	I_{CES}	-	6.0	mA	$V_{CE}=28$ V
Thermal Resistance	$R_{TH(JC)}$	-	0.8	°C/W	$V_{CC}=28$ V, $P_{IN}=12$ W, $F=1.20, 1.30, 1.40$ GHz
Output Power	P_{OUT}	55	-	W	$V_{CC}=28$ V, $P_{IN}=12$ W, $F=1.20, 1.30, 1.40$ GHz
Power Gain	G_p	6.6	-	dB	$V_{CC}=28$ V, $P_{IN}=12$ W, $F=1.20, 1.30, 1.40$ GHz
Collector Efficiency	η_c	50	-	%	$V_{CC}=28$ V, $P_{IN}=12$ W, $F=1.20, 1.30, 1.40$ GHz
Input Return Loss	RL	10	-	dB	$V_{CC}=28$ V, $P_{IN}=12$ W, $F=1.20, 1.30, 1.40$ GHz
Load Mismatch Tolerance	VSWR-T	-	3:1	-	$V_{CC}=28$ V, $P_{IN}=12$ W, $F=1.20, 1.30, 1.40$ GHz
Load Mismatch Stability	VSWR-S	-	1.5:1	-	$V_{CC}=28$ V, $P_{IN}=12$ W, $F=1.20, 1.30, 1.40$ GHz

Broadband Test Fixture Impedances

F(GHz)	$Z_{IF}(\Omega)$	$Z_{OF}(\Omega)$
1.20	5.7 + j1.8	5.5 - j3.4
1.30	2.4 + j1.3	3.3 - j2.3
1.40	2.4 + j0.6	2.0 - j2.3

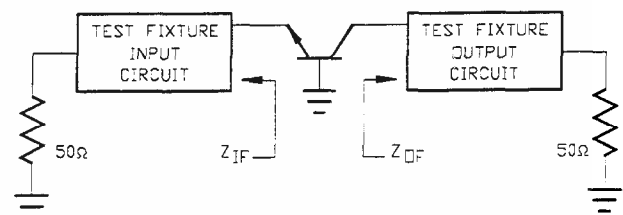

RF Test Fixture

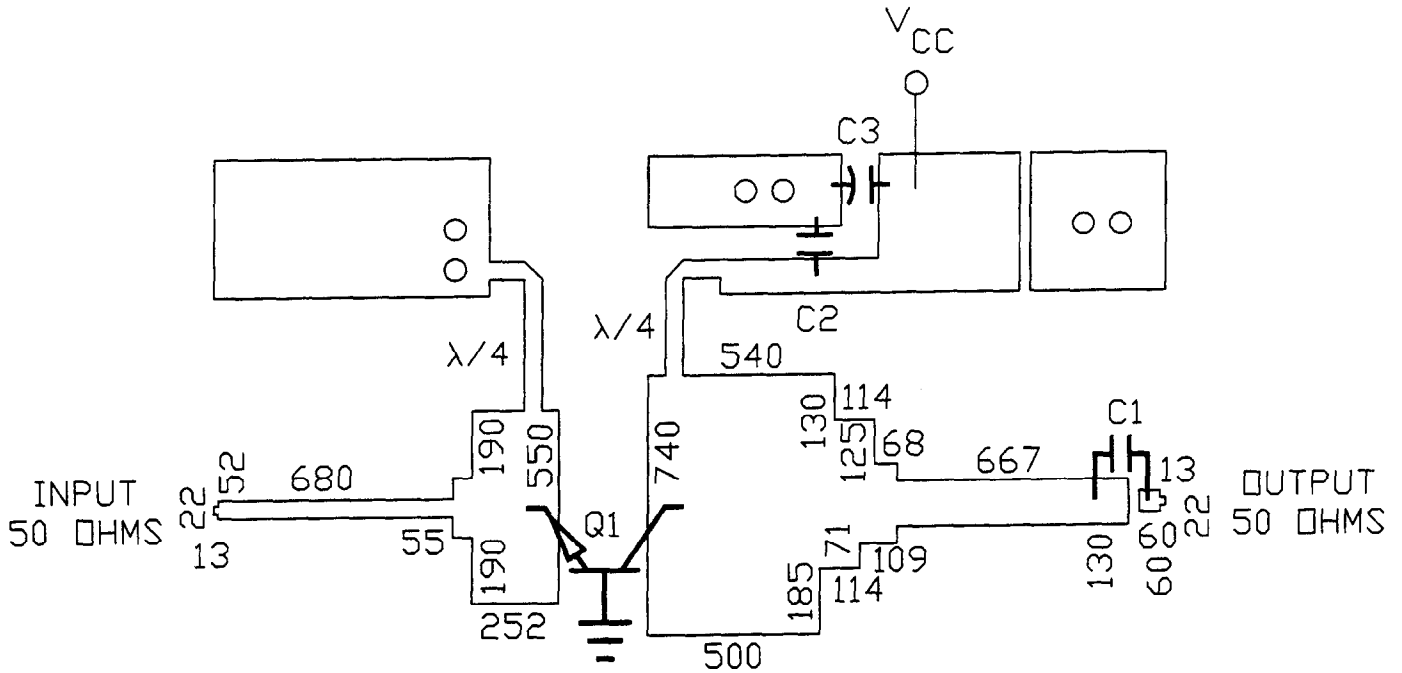

ARTWORK DIMENSIONS IN MILS

PARTS LIST

- C1 C2 100 pF ATC SIZE A
- C3 47 uF 63 VOLTS
- Q1 PH1214-40M
- BOARD TYPE: ROGERS 6010.5 .025" THICK, $E_R = 10.5$

Specifications Subject to Change Without Notice.

M/A-COM, Inc.

North America: Tel. (800) 366-2266
Fax (800) 618-8883

Asia/Pacific: Tel. +81 (03) 3226-1671
Fax +81 (03) 3226-1451

Europe: Tel. +44 (1344) 869 595
Fax +44 (1344) 300 020