

## 1.8V, LVDS Compliant, 4 Differential Channel, 2:1 Mux/DeMux Switch w/Single Enable

### Features

- 4 Differential Channel, 2:1 Mux/DeMux
- LVDS signal switching beyond 3.6 Gbps
- Low insertion loss, -2.88dB @ 2.9 Gbps
- Low bit-to-bit skew, 10ps max
- Low Off Isolation: -77dB@10 MHz
- Low crosstalk: -68dB@10 MHz
- V<sub>CC</sub> Operating Range: +1.5V to +2.0V
- ESD Tolerance: 8kV HBM I/O; 2kV HBM select pin
- Packaging (Pb-free & Green):
  - 42-contact TQFN (ZH)

### Description

Pericom Semiconductor's PI2LVD412 is an 8-to-4 differential channel multiplexer/demultiplexer switch. The device is bidirectional and designed specifically for Low Voltage Differential Signals. Users can take advantage of low bit-to-bit skew and high channel-to-channel noise isolation.

### Application

Routes multiple Low Voltage Differential Signals at high-speed data rates with little or no attenuation.

### Block Diagram

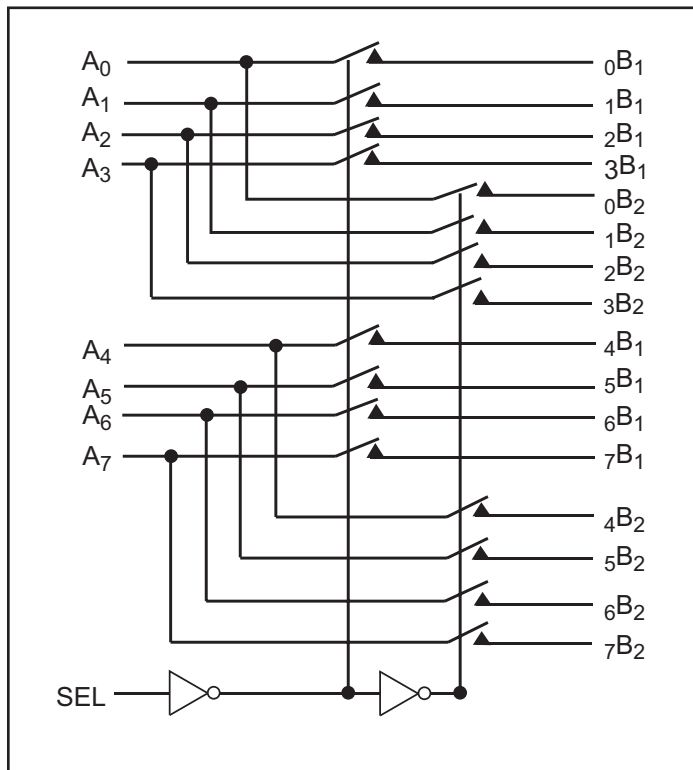

### Truth Table

Function	SEL
A <sub>N</sub> to N <sub>B</sub> 1	L
A <sub>N</sub> to N <sub>B</sub> 2	H

### Pin Configuration

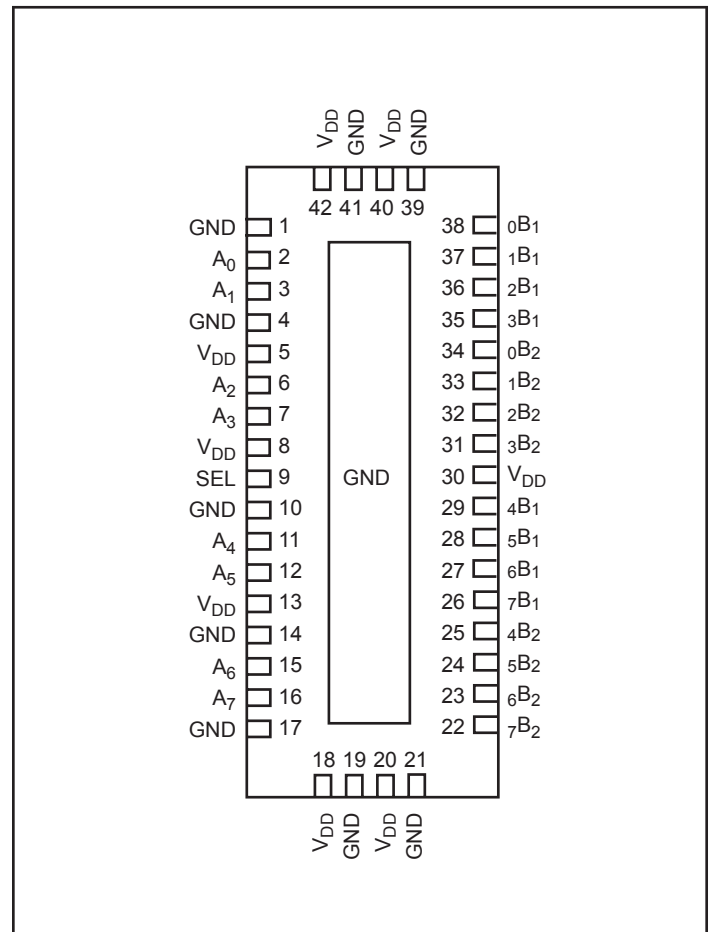

### Maximum Ratings

(Above which useful life may be impaired. For user guidelines, not tested.)

Storage Temperature.....	-65°C to +150°C
Supply Voltage to Ground Potential.....	-0.5V to +2.5V
DC Input Voltage .....	-0.5V to V <sub>CC</sub>
DC Output Current.....	120mA
Power Dissipation.....	0.5W

**Note:**

Stresses greater than those listed under MAXIMUM RATINGS may cause permanent damage to the device. This is a stress rating only and functional operation of the device at these or any other conditions above those indicated in the operational sections of this specification is not implied. Exposure to absolute maximum rating conditions for extended periods may affect reliability.

### DC Electrical Characteristics for Switching over Operating Range (T<sub>A</sub> = -40°C to +85°C, V<sub>CC</sub> = 1.5V to 2.0V)

Parameter	Description	Test Conditions <sup>(1)</sup>	Min.	Typ. <sup>(2)</sup>	Max.	Units
V <sub>IH</sub>	Input HIGH Voltage	Guaranteed HIGH level	0.65 x V <sub>CC</sub>			V
V <sub>IL</sub>	Input LOW Voltage	Guaranteed LOW level	-0.5		0.35 x V <sub>CC</sub>	
V <sub>IK</sub>	Clamp Diode Voltage	V <sub>CC</sub> = Max., I <sub>IN</sub> = -18mA		-0.7	-1.2	
I <sub>IH</sub>	Input HIGH Current	V <sub>CC</sub> = Max., V <sub>IN</sub> = V <sub>CC</sub>			±5	µA
I <sub>IL</sub>	Input LOW Current	V <sub>CC</sub> = Max., V <sub>IN</sub> = GND			±5	
R <sub>FLAT(ON)</sub>	On-Resistance Flatness <sup>(4)</sup>	V <sub>CC</sub> = Min., 0V ≤ V <sub>IN</sub> ≤ 1.5V and V <sub>CC</sub> , I <sub>IN</sub> = -40mA		1		
ΔR <sub>ON</sub>	On-Resistance match from center ports to any other port <sup>(5)</sup>	V <sub>CC</sub> = Min., 0V ≤ V <sub>IN</sub> ≤ 1.5V, I <sub>IN</sub> = -40mA		0.9		

### Power Supply Characteristics

Parameters	Description	Test Conditions <sup>(1)</sup>	Min.	Typ. <sup>(2)</sup>	Max.	Units
I <sub>CC</sub>	Quiescent Power Supply Current	V <sub>CC</sub> = Max., V <sub>IN</sub> = GND or V <sub>CC</sub>		200		µA

### Dynamic Electrical Characteristics Over the Operating Range (T<sub>A</sub> = -40° to +85°C, V<sub>CC</sub> = 1.8V±10%, GND=0V)

Parameter <sup>(3)</sup>	Description	Test Conditions <sup>(1)</sup>	Min.	Typ. <sup>(2)</sup>	Max.	Units
X <sub>TALK</sub>	Crosstalk	See Fig. 1 for Measurement Setup, f = 10 MHz		-68		dB
O <sub>IRR</sub>	OFF Isolation	See Fig. 2 for Measurement Setup, f = 10 MHz		-77		
-3dB BW	Bandwidth	See Fig. 3 for measurement Setup		1.8		GHz

**Notes:**

- For Max. or Min. conditions, use appropriate value specified under Electrical Characteristics for the applicable device type.
- Typical values are at V<sub>CC</sub> = 1.8V, T<sub>A</sub> = 25°C ambient and maximum loading.
- Guaranteed by design.
- Flatness is defined as the difference between the max and min value of On-Resistance.
- ΔR<sub>ON</sub> = R<sub>ON</sub> max - R<sub>ON</sub> min

**Switching Characteristics** ( $T_A = -40^\circ$  to  $+85^\circ\text{C}$ ,  $V_{CC} = 1.8\text{V} \pm 10\%$ )

Parameter	Description	Min. <sup>(1)</sup>	Max. <sup>(1)</sup>	Units
tPZH, tPZL	Line Enable Time - SEL to A <sub>N</sub> , B <sub>N</sub>	0.5	8.0	ns
tPHZ, tPLZ	Line Disable Time - SEL to A <sub>N</sub> , B <sub>N</sub>	0.5	4.0	
t <sub>b-b</sub>	Bit-to-bit skew		10	ps
t <sub>ch-ch</sub>	Channel-to-channel skew		35	ps

**Note:**

1. For max. or min. conditions, use appropriate value specified under Electrical Characteristics for the applicable device type.

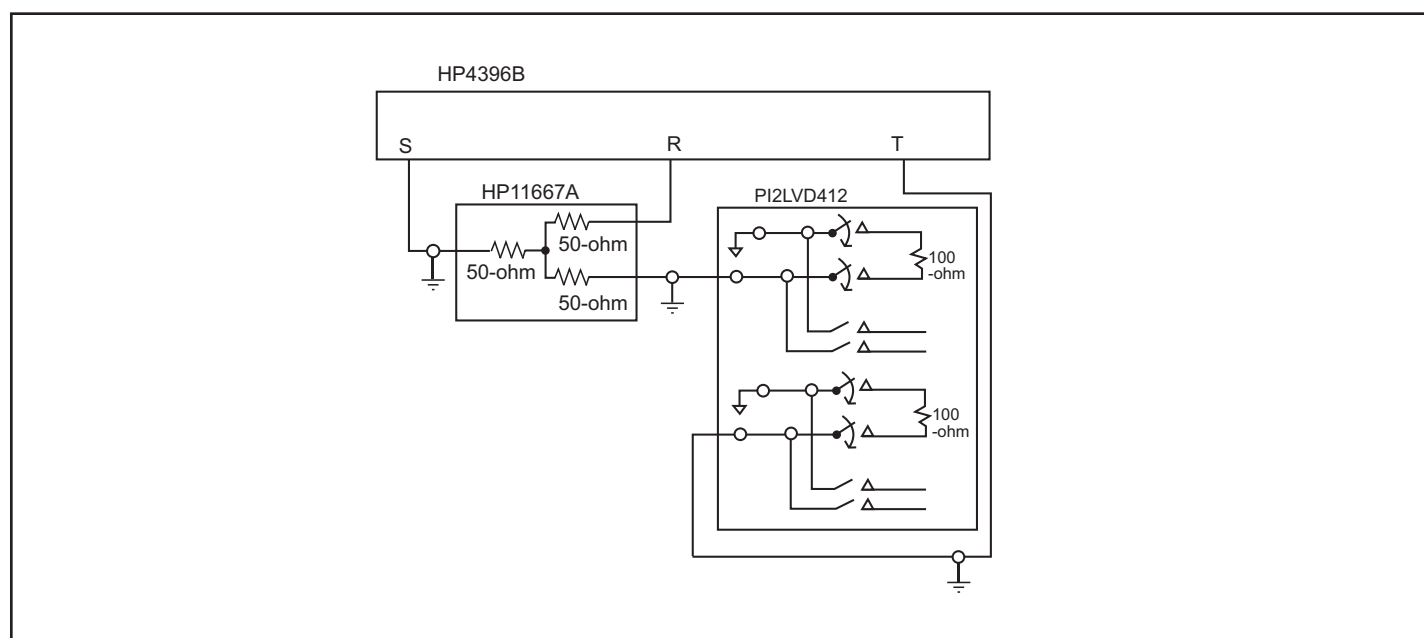

**Fig 1. Crosstalk Setup**

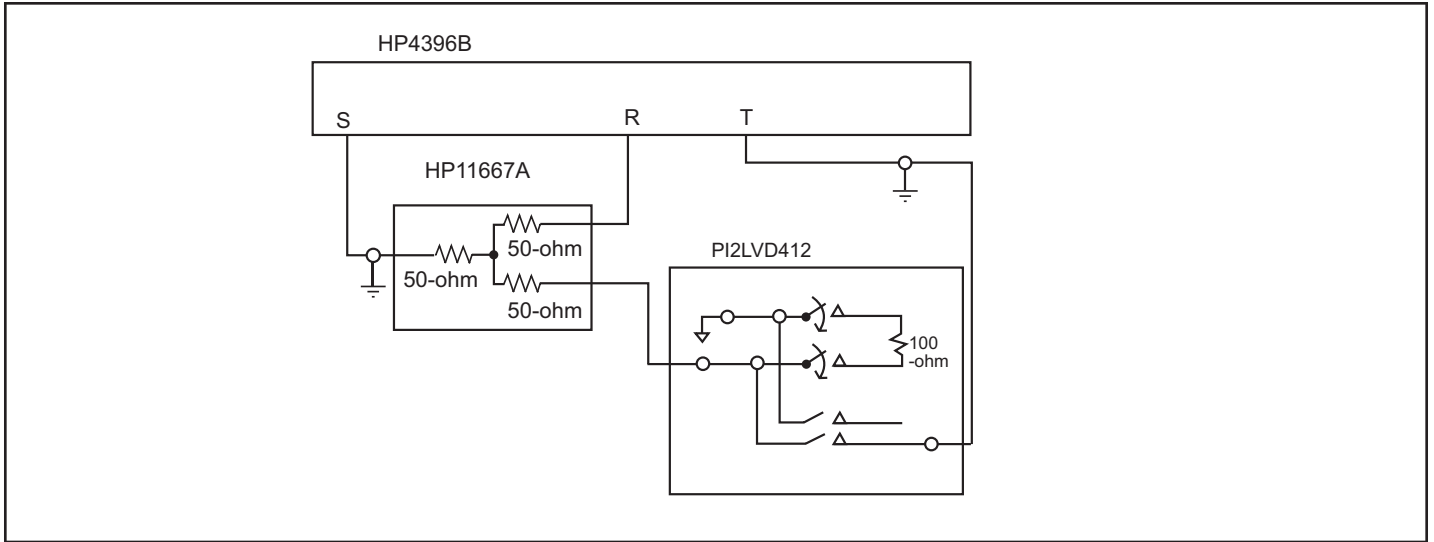

**Fig 2. Off-isolation setup**

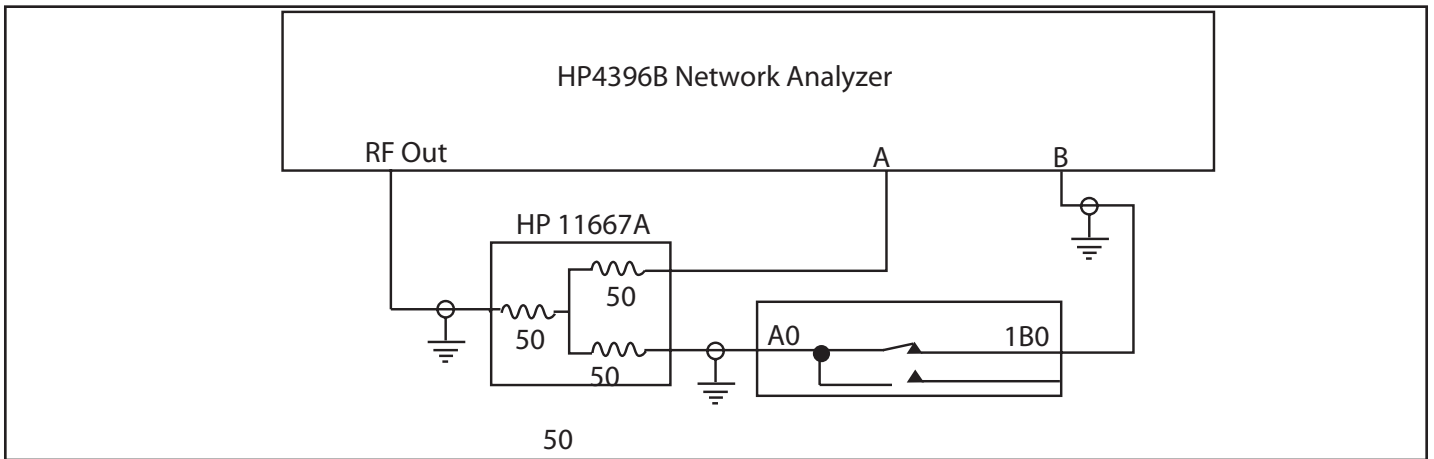

**Fig 3. Bandwidth Setup**

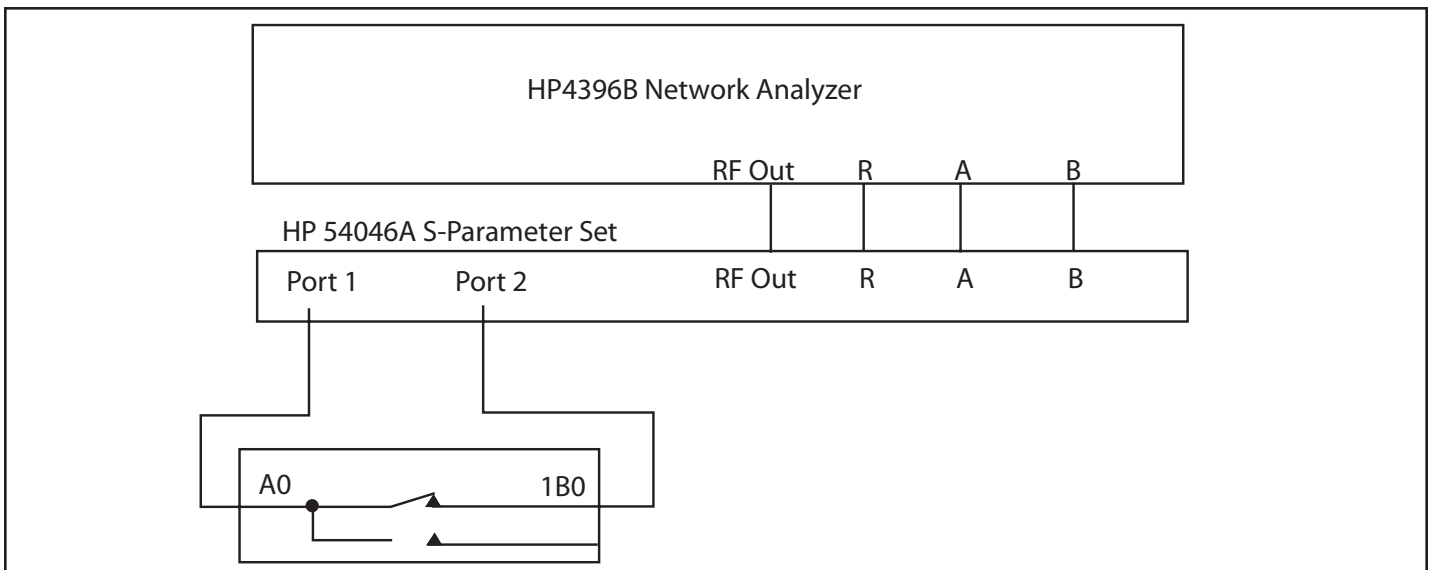

**Fig 4. S21 (Insertion Loss) and S11 (Reflection Signal) Setup**

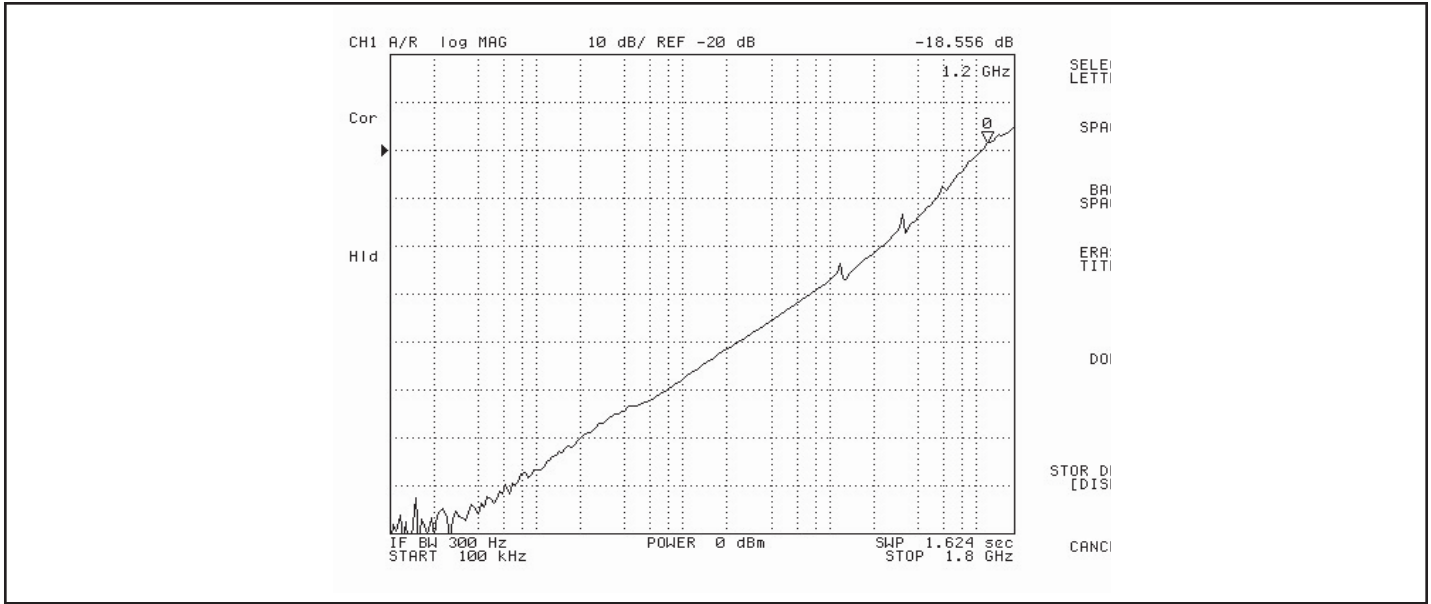

Fig 5. Crosstalk,  $V_{CC} = 1.8V$ ,  $25^{\circ}C$

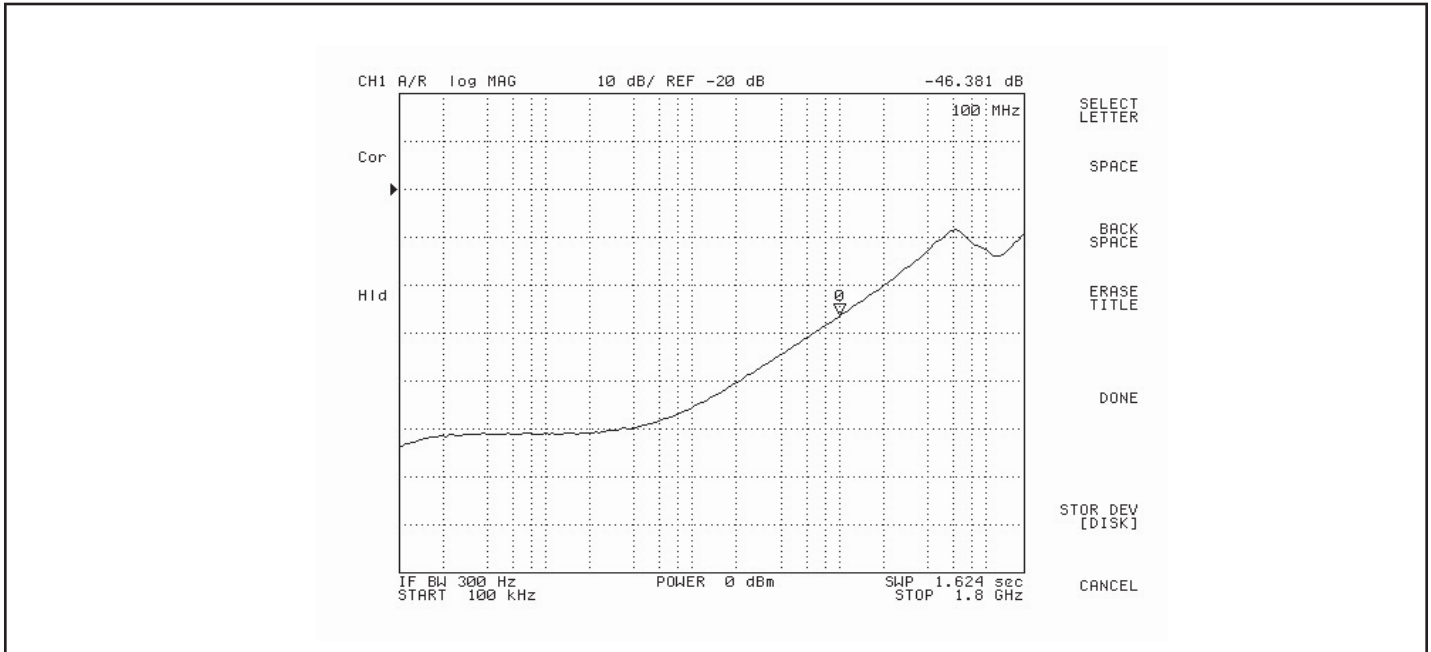

Fig 6. Off Isolation,  $V_{CC} = 1.8V$ ,  $25^{\circ}C$

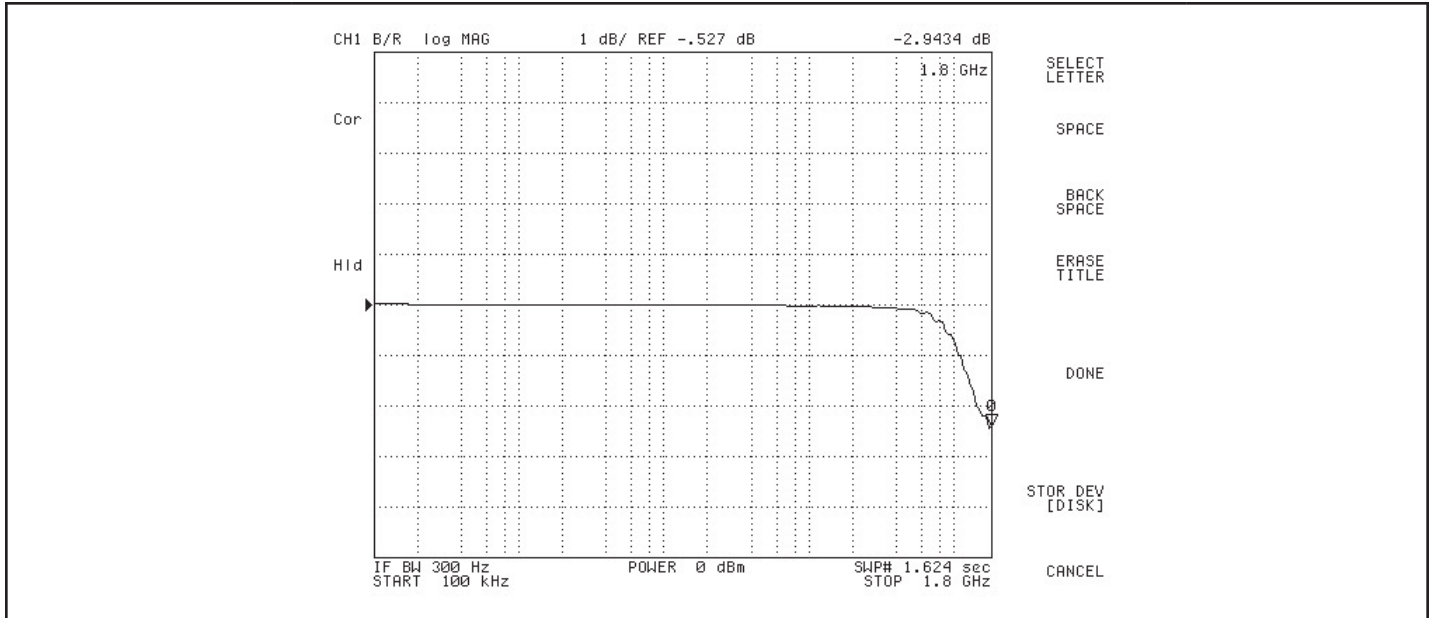

Fig 7. -3 dB Bandwidth, Vcc=1.8V, 25°C

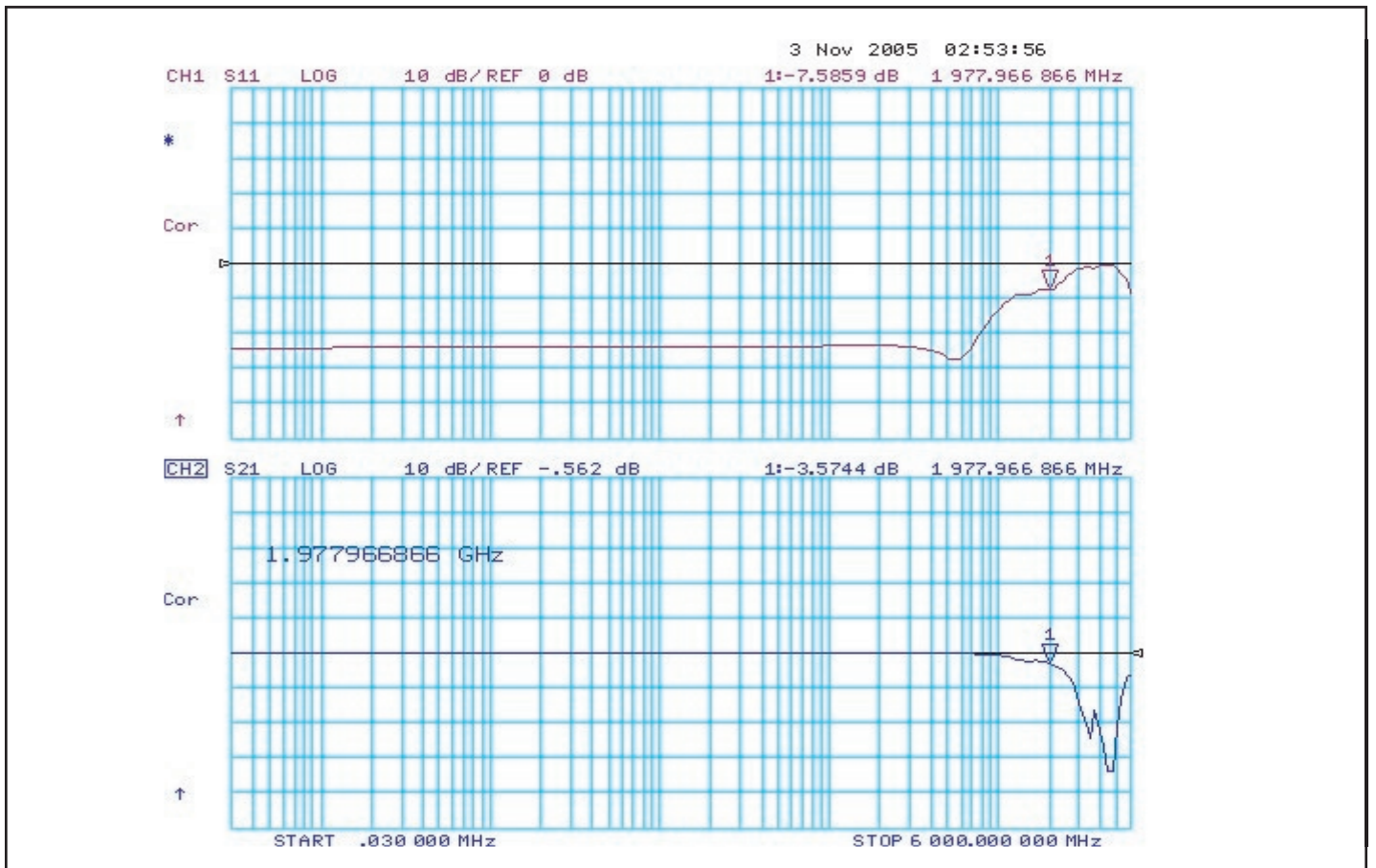
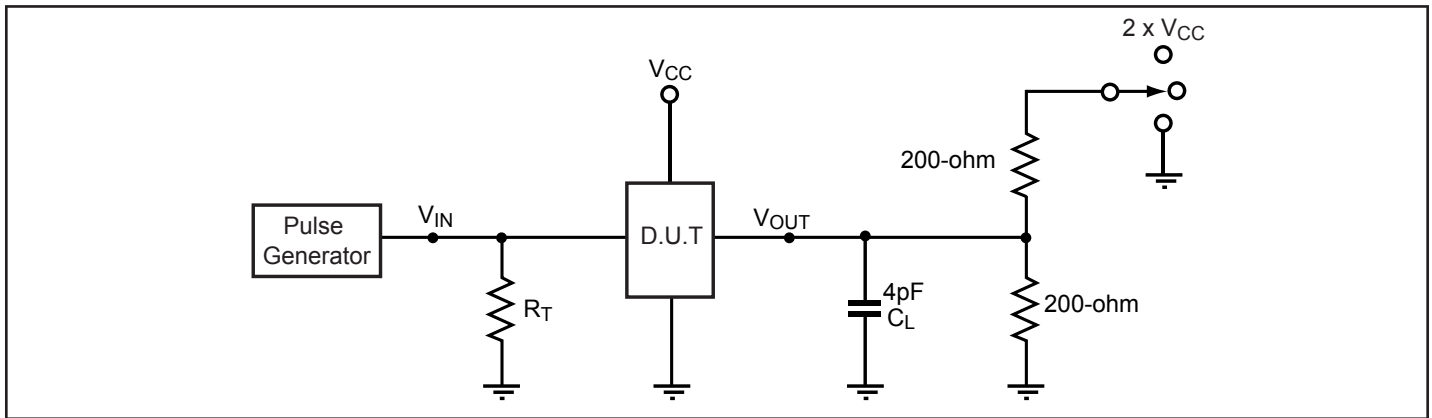

Fig 8. Return and Insertion Loss Log Diagram  
 from 30kHz to 6.0GHz using Matching Cables, Vcc=1.8V, 25C

### Test Circuit for Electrical Characteristics



#### Notes:

- $C_L$  = Load capacitance: includes jig and probe capacitance.
- $R_T$  = Termination resistance: should be equal to  $Z_{OUT}$  of the Pulse Generator.
- Waveform 1 is for an output with internal conditions such that the output is low except when disabled by the output control.  
Waveform 2 is for an output with internal conditions such that the output is high except when disabled by the output control.
- All input impulses are supplied by generators having the following characteristics:  $PRR \leq \text{MHz}$ ,  $Z_O = 50\Omega$ ,  $t_R \leq 2.5\text{ns}$ ,  $t_F \leq 2.5\text{ns}$ .
- The outputs are measured one at a time with one transition per measurement.

### Switch Positions

Test	Switch
$t_{PLZ}$ , $t_{PZL}$ (output on B-side)	$2 \times V_{CC}$
$t_{PHZ}$ , $t_{PHZ}$ (output on B-side)	GND
Prop Delay	Open

### Test Circuit for Dynamic Electrical Characteristics

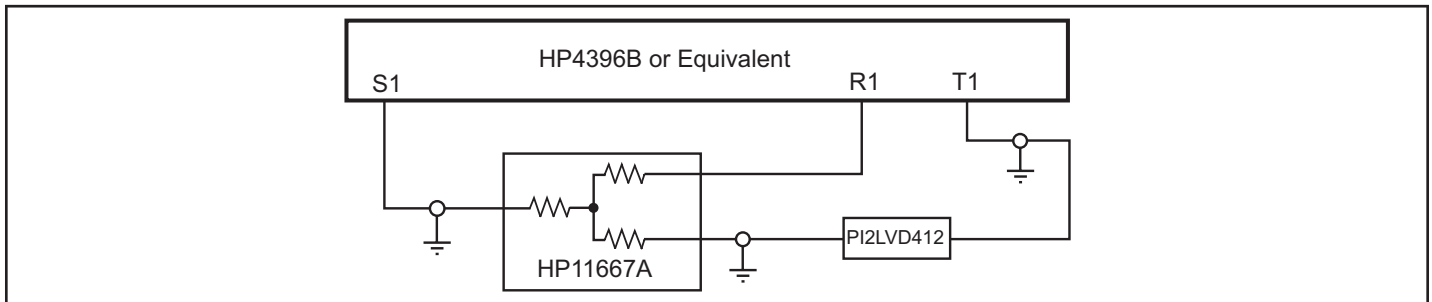

### Switching Waveforms

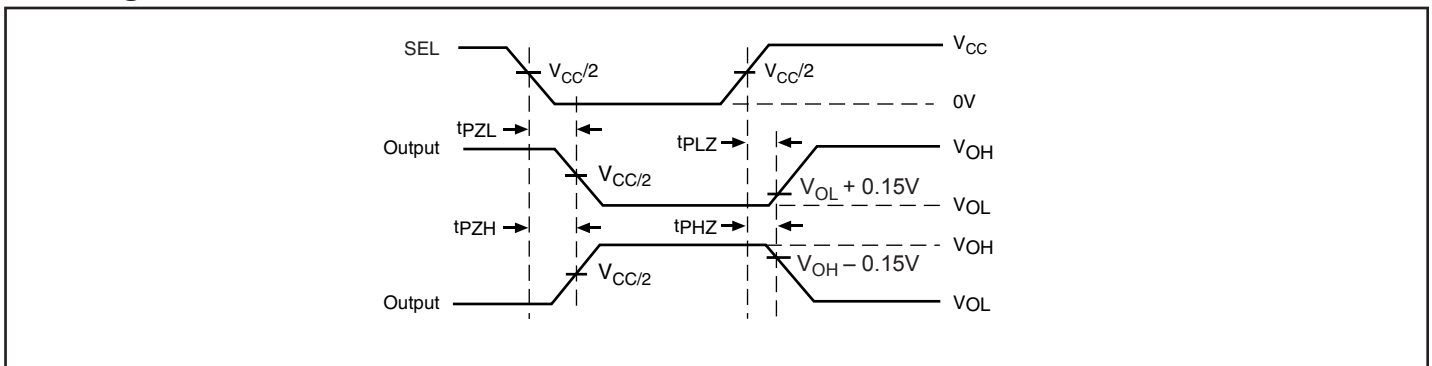

Voltage Waveforms Enable and Disable Times

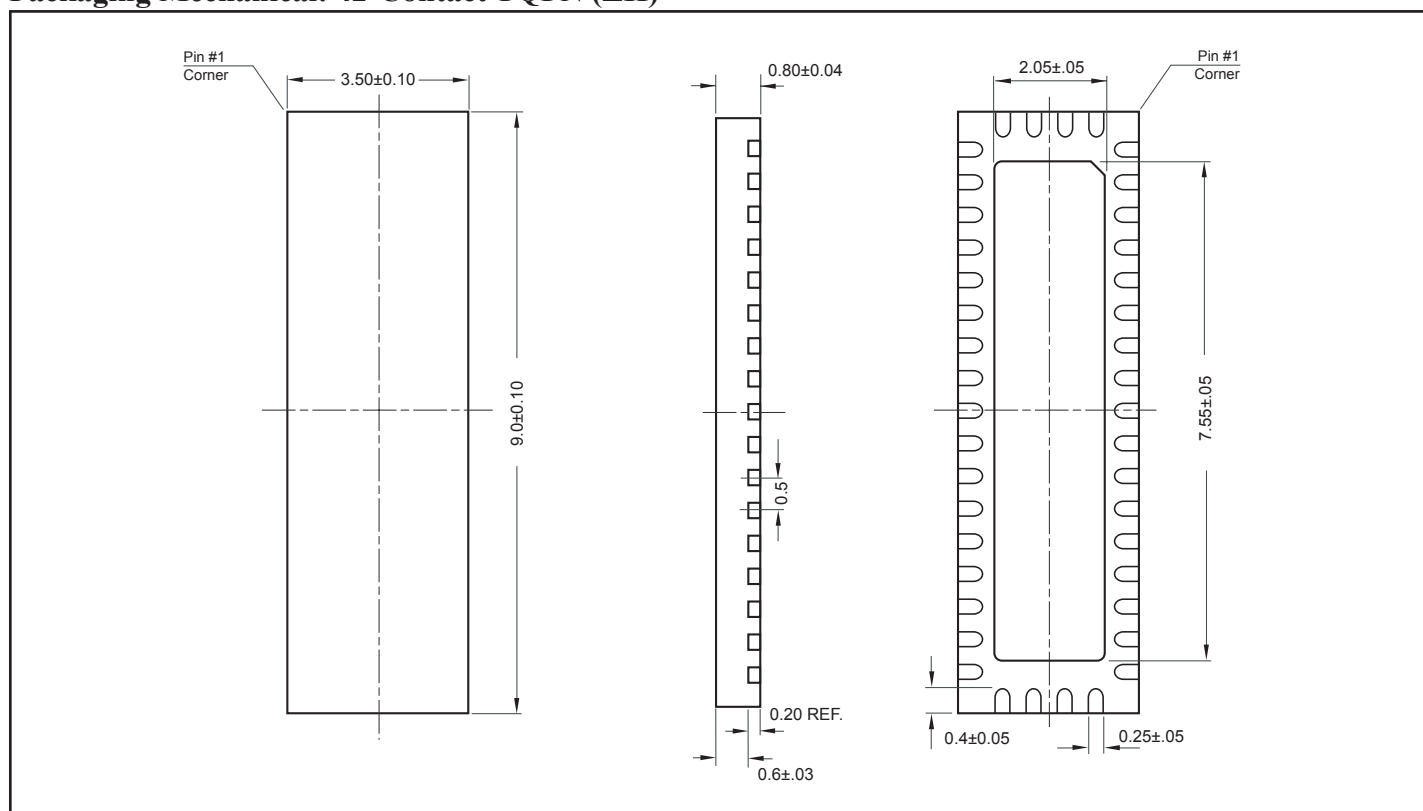
**Packaging Mechanical: 42-Contact TQFN (ZH)**

**Ordering Information**

Ordering Code	Package Code	Package Description
PI2LVD412ZHE	ZH	Pb-free & Green, 42-Contact TQFN

**Notes:**

- Thermal characteristics can be found on the company web site at [www.pericom.com/packaging/](http://www.pericom.com/packaging/)
- E = Pb-free and Green
- X Suffix = Tape/Reel