



PI3B3257

3.3V, Quad 2:1 Mux/Demux Bus Switch

Product Features

- Near zero propagation delay
- 5-ohm switches connect inputs to outputs
- Fast Switching Speed: 4.8ns max.
- Ultra-Low Quiescent Power: 0.1µA typical
– Ideally suited for notebook applications
- Pin compatible with 74 series 257 logic devices
- Packages available:
 - 16-pin 150 mil wide plastic QSOP (Q)
 - 16-pin 150 mil wide plastic SOIC (W)
 - 16-pin 173 mil wide plastic TSSOP (L)

Product Description

Pericom Semiconductor's PI3B series of logic circuits are produced using the Company's advanced submicron CMOS technology, achieving industry leading performance.

The PI3B3257 is a 3.3 Volt, Quad 2:1 multiplexer/demultiplexer with three-state outputs that is pinout and function compatible with the PI74FCT257T, 74F257, and 74ALS/AS/LS257. Inputs can be connected to outputs with low ON resistance (5 ohms) with no additional ground bounce noise or propagation delay.

Logic Block Diagram

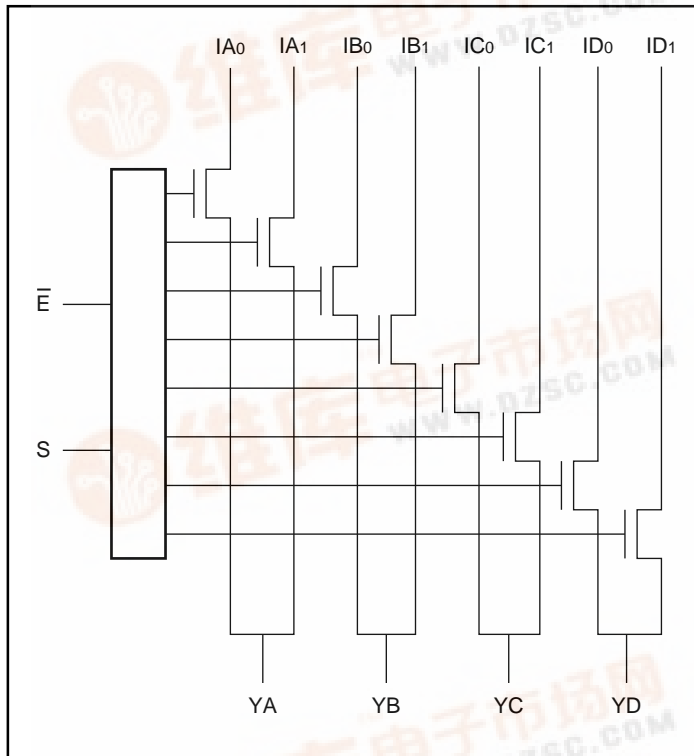

16-Pin Product Configuration

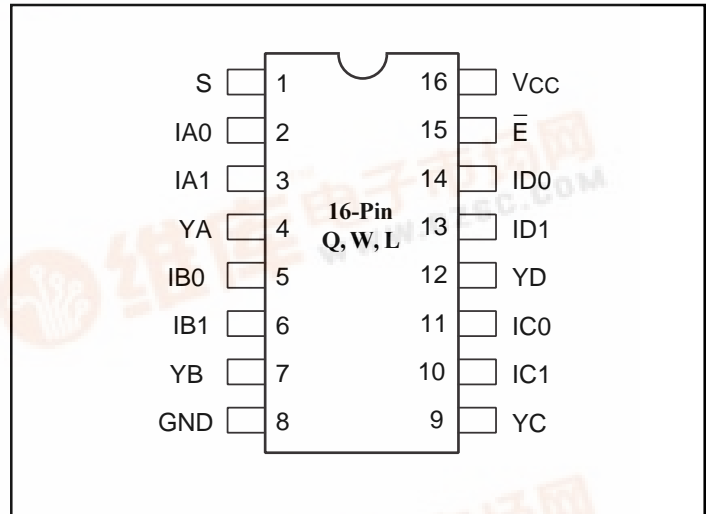

Truth Table⁽¹⁾

\bar{E}	S	YA	YB	YC	YD	Function
H	X	Hi-Z	Hi-Z	Hi-Z	Hi-Z	Disable
L	L	IA0	IB0	IC0	ID0	S = 0
L	H	IA1	IB1	IC1	ID1	S = 1

Product Pin Description

Pin Name	Description
IA _n -ID _n	Data Inputs
S	Select Inputs
\bar{E}	Enable
YA-YD	Data Outputs
GND	Ground
Vcc	Power
NC	No Connect





Maximum Ratings

(Above which the useful life may be impaired. For user guidelines, not tested.)

Storage Temperature	-65°C to +150°C
Ambient Temperature with Power Applied	-40°C to +85°C
Supply Voltage to Ground Potential	-0.5V to +4.6V
DC Input Voltage	-0.5V to +4.6V
DC Output Current	120mA
Power Dissipation	0.5W

Note:

Stresses greater than those listed under MAXIMUM RATINGS may cause permanent damage to the device. This is a stress rating only and functional operation of the device at these or any other conditions above those indicated in the operational sections of this specification is not implied. Exposure to absolute maximum rating conditions for extended periods may affect reliability.

DC Electrical Characteristics (Over the Operating Range, $T_A = -40^\circ\text{C}$ to $+85^\circ\text{C}$, $V_{CC} = 3.3\text{V} \pm 10\%$)

Parameters	Description	Test Conditions ⁽¹⁾	Min.	Typ. ⁽²⁾	Max.	Units
V_{IH}	Input HIGH Voltage	Guaranteed Logic HIGH Level	2.0			V
V_{IL}	Input LOW Voltage	Guaranteed Logic LOW Level	-0.5		0.8	
I_{IH}	Input HIGH Current	$V_{CC} = \text{Max.}, V_{IN} = V_{CC}$			± 1	μA
I_{IL}	Input LOW Current	$V_{CC} = \text{Max.}, V_{IN} = \text{GND}$			± 1	
I_{OZH}	High Impedance Output Current	$0 \leq I_N, Y_N \leq V_{CC}$			± 1	
V_{IK}	Clamp Diode Voltage	$V_{CC} = \text{Min.}, I_{IN} = -18\text{mA}$			-1.2	V
R_{ON}	Switch ON Resistance ⁽³⁾	$V_{CC} = \text{Min.}, V_{IN} = 0.0\text{V}, I_{ON} = 48\text{mA}$ or 64mA $V_{CC} = \text{Min.}, V_{IN} = 2.4\text{V}, I_{ON} = 15\text{mA}$		5 10	8 17	Ω

Capacitance ($T_A = 25^\circ\text{C}$, $f = 1\text{MHz}$)

Parameters	Description	Test Conditions	Typical	Units
C_{IN}	Input Capacitance	$V_{IN} = 0\text{V}$	3.0	pF
C_{OFFYN}	Y_N Capacitance, Switch Off	$V_{IN} = 0\text{V}$	17.0	
C_{OFFIN}	I_N Capacitance, Switch Off	$V_{IN} = 0\text{V}$	8.5	
C_{ON}	I_N/Y_N Capacitance, Switch On	$V_{IN} = 0\text{V}$	25.0	

Notes:

- For Max. or Min. conditions, use appropriate value specified under Electrical Characteristics for the applicable device type.
- Typical values are at $V_{CC} = 3.3\text{V}$, $T_A = 25^\circ\text{C}$ ambient and maximum loading.
- Measured by the voltage drop between I and Y pin at indicated current through the switch. ON resistance is determined by the lower of the voltages on the two (I, Y) pins.
- This parameter is determined by device characterization but is not production tested.



Power Supply Characteristics

Parameters	Description	Test Conditions ⁽¹⁾		Min.	Typ ⁽²⁾	Max.	Units
I _{CC}	Quiescent Power Supply Current	V _{CC} = Max.	V _{IN} = GND or V _{CC}		0.1	3.0	μA
ΔI _{CC}	Supply Current per Input @ TTL HIGH ^(3,4)	V _{CC} = Max.	V _{IN} = 3.0V			750	

Notes:

1. For Max. or Min. conditions, use appropriate value specified under Electrical Characteristics for the applicable device.
2. Typical values are at V_{CC} = 3.3V, +25°C ambient.
3. Per TTL driven input (control inputs only); I and Y pins do not contribute to I_{CC}.
4. This current applies to the control inputs only and represent the current required to switch internal capacitance at the specified frequency. The I and Y inputs generate no significant AC or DC currents as they transition. This parameter is not tested, but is guaranteed by design.

Switching Characteristics over Operating Range

Parameters	Description	Conditions ⁽¹⁾	PI3B3257		Units
			Com.		
			Min.	Max.	
t _{IY}	Propagation Delay In to Yn ^(2,3)	C _L = 50pF R _L = 500Ω		0.25	ns
t _{SY}	Bus Select Time, Sn to Yn		1	4.5	
t _{PZH} t _{PZL}	Bus Enable Time, E to Yn		1	4.5	
t _{PHZ} t _{PLZ}	Bus Disable Time, E to Yn		1	4.8	

Notes:

1. See test circuit and waveforms.
2. This parameter is guaranteed but not tested on Propagation Delays.
3. The bus switch contributes no propagational delay other than the RC delay of the ON resistance of the switch and the load capacitance. The switch's time constant alone is of the order of 0.25ns for 50pF load. Since this time constant is much smaller than the rise/fall times of typical driving signals, it adds very little propagational delay to the system. Propagational delay of the bus switch when used in a system is determined by the driving circuit on the driving side of the switch and its interaction with the load on the driven side.

16-Pin TSSOP (L) Package

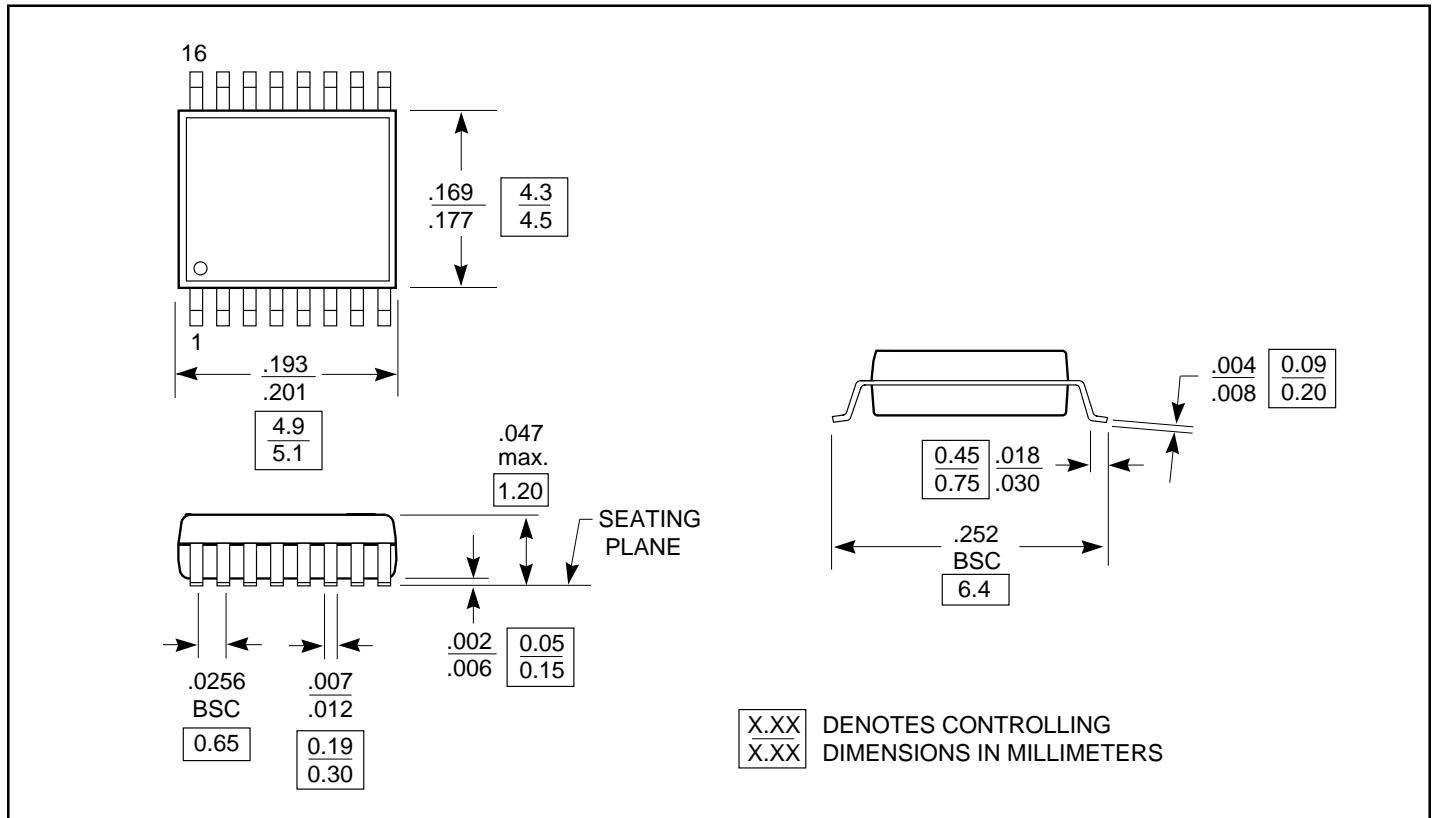

Ordering Information

Part	Pin-Package	Width
PI3B3257Q	16 - QSOP(Q)	150-mil
PI3B3257W	16 - SOIC (W)	150-mil
PI3B3257L	16 - TSSOP (L)	173-mil