



PI3V512

Low On-Resistance, 3.3V Wideband/Video Switch 5-Port, 2:1 Mux/DeMux

Features

- RON is 4Ω typical
- Low bit-to-bit skew: 200ps
- Low crosstalk: -65dB @ 10MHz
- Low Current Consumption: 20μA
- Near-Zero propagation delay: 250ps
- Switching speed: 9ns
- Channel On-Capacitance: 6pF (typical)
- VCC Operating Range: +3.0V to +3.6V
- ESD>2000V . . . Human Body Model
- High Signal Passing bandwidth (600 MHz)
- Packaging (Pb-free & Green available):
24-pin QSOP (Q)

Applications

- Projection TV and LCD TV
- Video consumer applications
- Analog video signal processing

Description

Pericom Semiconductor's PI3V512 is a true bi-directional 5-Port 2:1 multiplexer/demultiplexer with Hi-Z outputs that is recommended for both RGB and composite video switching applications. With the additional 2 ports, vertical and horizontal synchronous signals can be switched in addition to switching the RGB and composite signals between different components, such as DVD, VCR, PCs and etc. The VideoSwitch can be driven from a current output RAMDAC or voltage output composite video source.

Low On-Resistance, Low Crosstalk, Low OFF Isolation and wide bandwidth features make it ideal for video and other applications. Industry leading advantages include a propagation delay of less than 250ps, resulting from its low channel resistance and I/O capacitance. The switch is bi-directional and offers little or no attenuation of the high-speed signals at the outputs. The device also has exceptional high current capability which is far greater than most analog switches offered today. The PI3V512 offers a high-performance (600 MHz), low-cost solution to switch between video sources.

Block Diagram

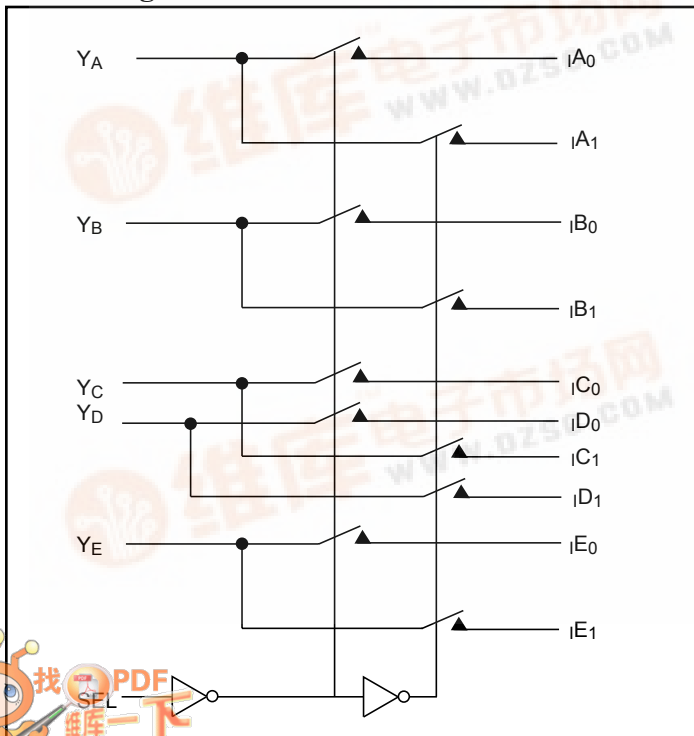

Pin Description

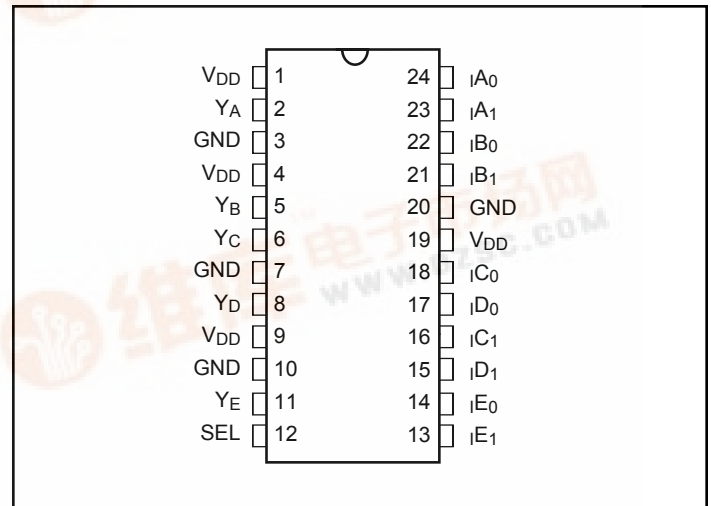



Maximum Ratings

(Above which useful life may be impaired. For user guidelines, not tested.)

Storage Temperature.....	-65°C to +150°C
Supply Voltage to Ground Potential.....	-0.5V to +4.0V
DC Input Voltage.....	-0.5V to +5.5V
DC Output Current.....	120mA
Power Dissipation.....	0.5W

Truth Table

Function	SEL
Y_N to I_N0	L
Y_N to I_N1	H

Note:

Stresses greater than those listed under MAXIMUM RATINGS may cause permanent damage to the device. This is a stress rating only and functional operation of the device at these or any other conditions above those indicated in the operational sections of this specification is not implied. Exposure to absolute maximum rating conditions for extended periods may affect reliability.

DC Electrical Characteristics for 1000 Base-T Ethernet Switching over Operating Range

($T_A = -40^\circ\text{C}$ to $+85^\circ\text{C}$, $V_{CC} = 3.3\text{V} \pm 10\%$)

Parameter	Description	Test Conditions	Min.	Typ. ⁽²⁾	Max.	Units
V_{IH}	Input HIGH Voltage	Guaranteed HIGH level	2	-	-	V
V_{IL}	Input LOW Voltage	Guaranteed LOW level	-0.5	-	0.8	
V_{IK}	Clamp Diode Voltage	$V_{CC} = \text{Max.}, I_{IN} = -18\text{mA}$	-	-0.7	-1.2	
I_{IH}	Input HIGH Current	$V_{CC} = \text{Max.}, V_{IN} = V_{CC}$	-	-	± 5	μA
I_{IL}	Input LOW Current	$V_{CC} = \text{Max.}, V_{IN} = \text{GND}$	-	-	± 5	
I_{OFF}	Power Down Leakage Current	$V_{CC} = 0\text{V}, V_A = 0\text{V}, V_B \leq 3.6$	-	-	-	
R_{ON}	Switch On-Resistance ⁽³⁾	$V_{CC} = \text{Min.}, 1.5\text{V} \leq V_{IN} \leq V_{CC}, I_{IN} = -40\text{mA}$	-	4	8	Ω
$R_{FLAT(ON)}$	On-Resistance Flatness ⁽⁴⁾	$V_{CC} = \text{Min.}, V_{IN} @ 1.5\text{V and } V_{CC}, I_{IN} = -40\text{mA}$	-	1	-	
ΔR_{ON}	On-Resistance match from center ports to any other port ⁽⁴⁾	$V_{CC} = \text{Min.}, 1.5\text{V} \leq V_{IN} \leq V_{CC}, I_{IN} = -40\text{mA}$	-	0.9	2	



DC Electrical Characteristics for 10/100 Base-T Ethernet Switching over Operating Range

($T_A = -40^{\circ}\text{C}$ to $+85^{\circ}\text{C}$, $V_{CC} = 3.3\text{V} \pm 10\%$)

Parameter	Description	Test Conditions	Min.	Typ. ⁽²⁾	Max.	Units
V_{IH}	Input HIGH Voltage	Guaranteed HIGH level	2.0	-	-	V
V_{IL}	Input LOW Voltage	Guaranteed LOW level	-0.5	-	0.8	
V_{IK}	Clamp Diode Voltage	$V_{CC} = \text{Max.}, I_{IN} = -18\text{mA}$	-	-0.7	-1.2	
I_{IH}	Input HIGH Current	$V_{CC} = \text{Max.}, V_{IN} = V_{CC}$	-	-	± 5	μA
I_{IL}	Input LOW Current	$V_{CC} = \text{Max.}, V_{IN} = \text{GND}$	-	-	± 5	
I_{OFF}	Power Down Leakage Current	$V_{CC} = 0\text{V}, V_A = 0\text{V}, V_B \leq 3.6$	-	-	-	
R_{ON}	Switch On-Resistance ⁽³⁾	$V_{CC} = \text{Min.}, 1.25\text{V} \leq V_{IN} \leq V_{CC}, I_{IN} = -10\text{mA}$ to -30mA	-	-	8	Ω
$R_{FLAT(ON)}$	On-Resistance Flatness ⁽⁴⁾	$V_{CC} = \text{Min.}, V_{IN} @ 1.25\text{V}$ and $V_{CC}, I_{IN} = -10\text{mA}$ to -30mA	-	1.0	-	
ΔR_{ON}	On-Resistance match from center ports to any other port ⁽⁴⁾	$V_{CC} = \text{Min.}, 1.25\text{V} \leq V_{IN} \leq V_{CC}, I_{IN} = -10\text{mA}$ to -30mA	-	0.9	2.0	

Capacitance ($T_A = 25^{\circ}\text{C}$, $f = 1\text{MHz}$)

Parameters ⁽⁵⁾	Description	Test Conditions	Typ.	Max.	Units
C_{IN}	Input Capacitance	$V_{IN} = 0\text{V}$	2.0	3.0	pF
$C_{OFF(IN0, IN1)}$	Port I Capacitance, Switch OFF		4.0	6.0	
$C_{ON(Y/I)}$	Y/I Capacitance, Switch ON		6.0	10.0	

Notes:

- For max. or min. conditions, use appropriate value specified under Electrical Characteristics for the applicable device type.
- Typical values are at $V_{CC} = 3.3\text{V}$, $T_A = 25^{\circ}\text{C}$ ambient and maximum loading.
- Measured by the voltage drop between Y and I pins at indicated current through the switch. On-Resistance is determined by the lower of the voltages on the two (Y & I) pins.
- This parameter is determined by device characterization but is not production tested.

Power Supply Characteristics

Parameters	Description	Test Conditions ⁽¹⁾	Min.	Typ. ⁽²⁾	Max.	Units
I_{CC}	Quiescent Power Supply Current	$V_{CC} = \text{Max.}, V_{IN} = \text{GND}$ or V_{CC}	-	-	800	μA

Notes:

- For max. or min. conditions, use appropriate value specified under Electrical Characteristics for the applicable device type.
- Typical values are at $V_{CC} = 3.3\text{V}$, $T_A = 25^{\circ}\text{C}$ ambient and maximum loading.
- Per TTL driven input (control inputs only); Y and I pins do not contribute to I_{CC} .



Dynamic Electrical Characteristics Over the Operating Range ($T_A = -40^\circ$ to $+85^\circ\text{C}$, $V_{CC} = 3.3\text{V} \pm 10\%$, $GND = 0\text{V}$)

Parameter	Description	Test Conditions	Min.	Typ. ⁽²⁾	Max.	Units
X _{TALK}	Crosstalk	See Test Diagram ($f = 10\text{ MHz}$)	-	-65	-	dB
O _{IRR}	OFF Isolation		-	-70	-	
BW	Bandwidth -3dB	See Test Diagram ($C_L = 0\text{ pF}$)	-	600	-	MHz

Switching Characteristics

Parameter	Description	Min.	Typ. ⁽²⁾	Max.	Units
t _{PD}	Propagation Delay ^(2,3)	-	0.25		ns
t _{pZH} , t _{pZL}	Line Enable Time - SEL to Y _N , I _N	0.5	-	15	
t _{pHZ} , t _{pLZ}	Line Disable Time - SEL to Y _N , I _N	0.5	-	9	
t _{SK(o)}	Output Skew between center port (YC to YD) to any other port ⁽²⁾	-	0.1	0.2	
t _{SK(p)}	Skew between opposite transitions of the same output (t _{PHL} - t _{PLH}) ⁽²⁾	-	0.1	0.2	

Notes:

- For max. or min. conditions, use appropriate value specified under Electrical Characteristics for the applicable device type.
- Guaranteed by design.
- The bus switch contributes no propagational delay other than the RC delay of the On-Resistance of the switch and the load capacitance. The time constant for the switch alone is of the order of 0.25ns for 10pF load. Since this time constant is much smaller than the rise/fall times of typical driving signals, it adds very little propagational delay to the system. Propagational delay of the bus switch when used in a system is determined by the driving circuit on the driving side of the switch and its interactions with the load on the driven side.

Bandwidth vs. Capacitance

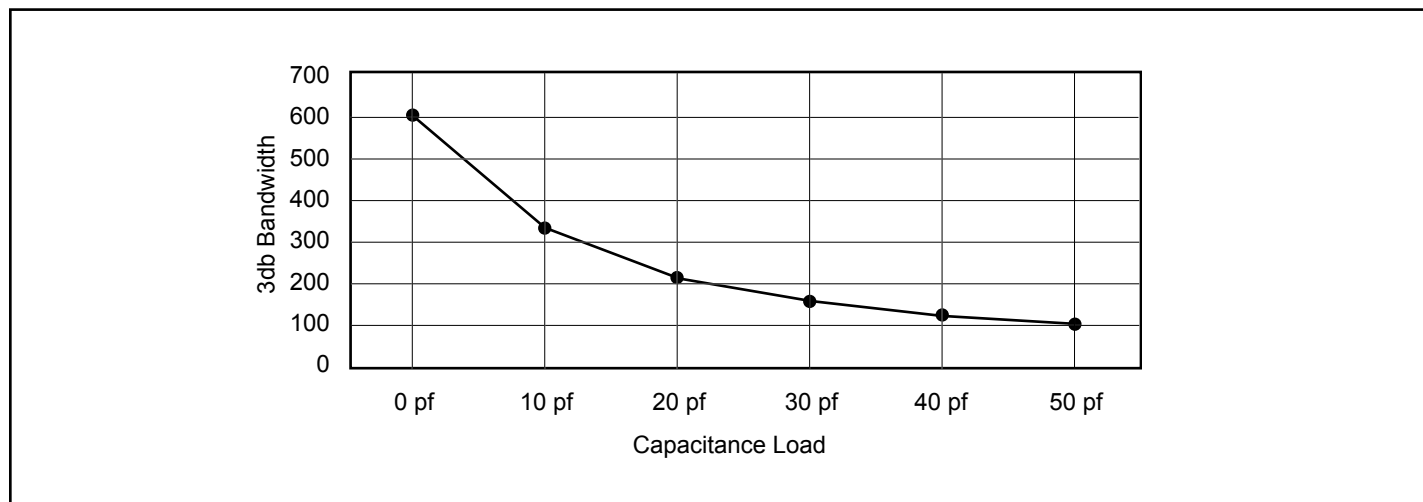

Test Circuit for Electrical Characteristics⁽¹⁾

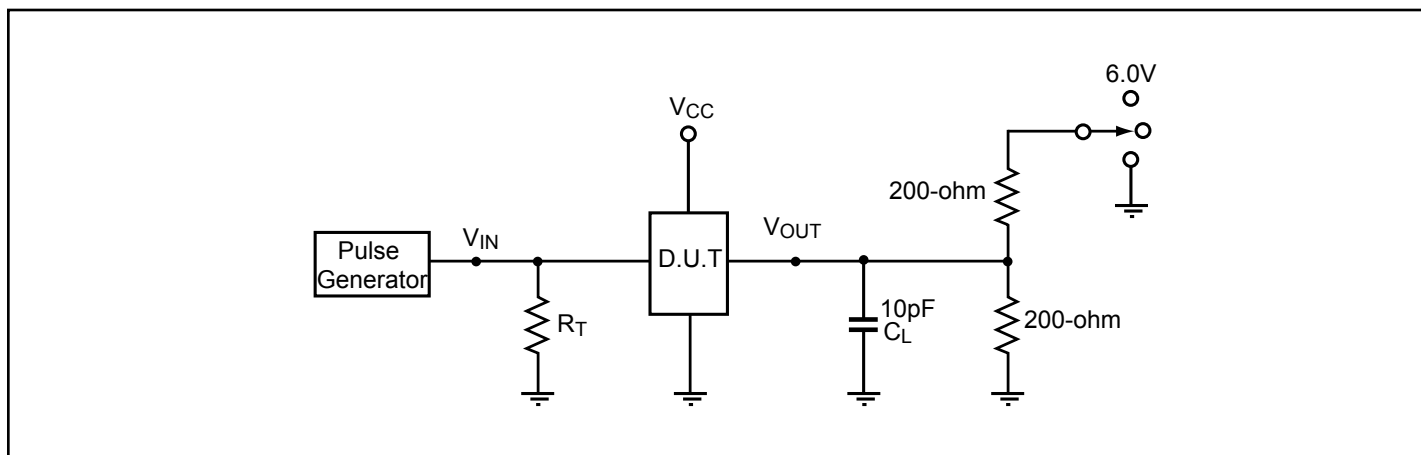

Notes:

1. C_L = Load capacitance: includes jig and probe capacitance.
2. R_T = Termination resistance: should be equal to Z_{OUT} of the Pulse Generator
3. Waveform 1 is for an output with internal conditions such that the output is low except when disabled by the output control.
Waveform 2 is for an output with internal conditions such that the output is high except when disabled by the output control.
4. All input impulses are supplied by generators having the following characteristics: $PRR \leq \text{MHz}$, $Z_O = 50\Omega$, $t_R \leq 2.5\text{ns}$, $t_F \leq 2.5\text{ns}$.
5. The outputs are measured one at a time with one transition per measurement.

Switch Positions

Test	Switch
t_{PLZ} , t_{PZL} (output on I side)	6.0V
t_{PHZ} , t_{PZH} (output on I side)	GND
Prop Delay	Open

Test Circuit for Dynamic Electrical Characteristics

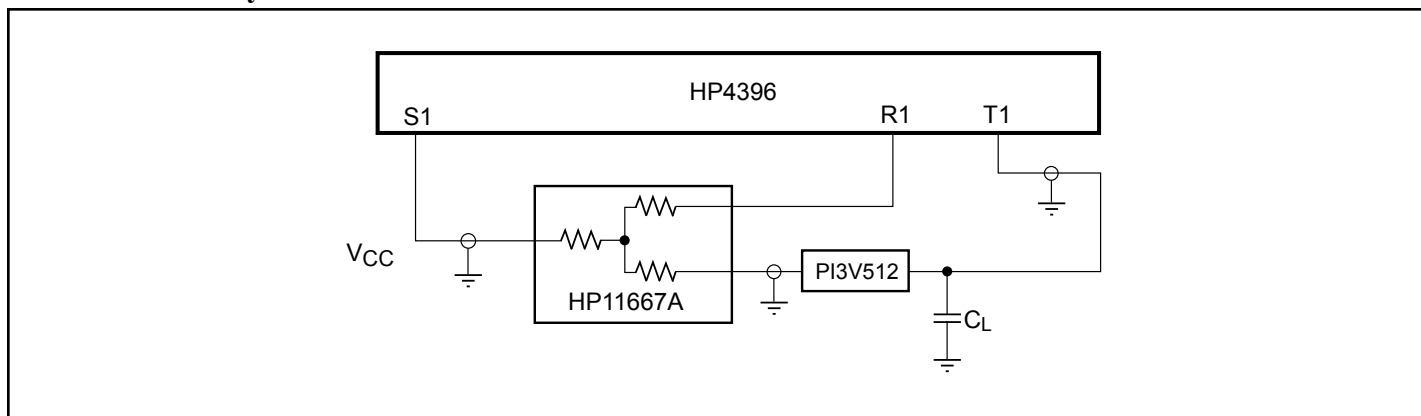

Off Isolation (V_{CC} 3.3V, 25°C)

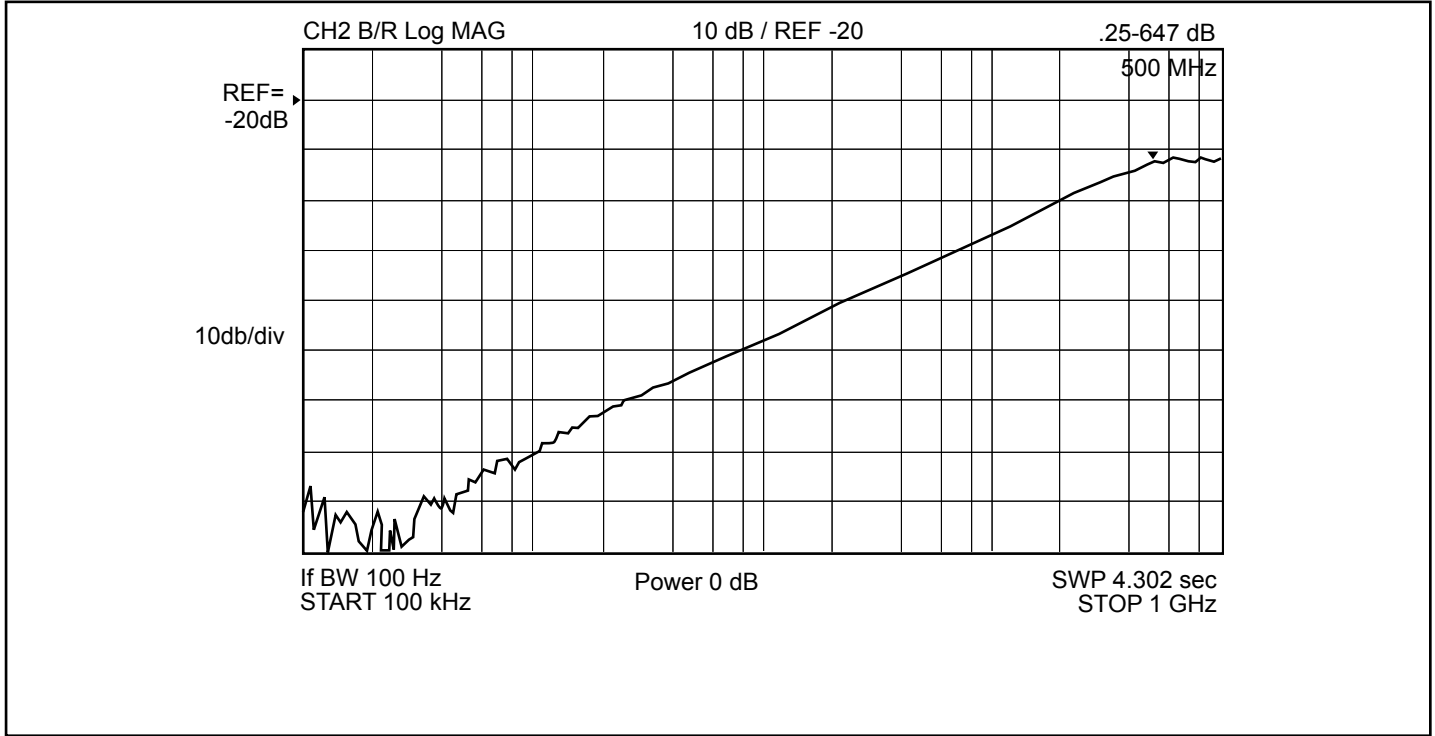

Crosstalk (V_{CC} 3.3V, 25°C)

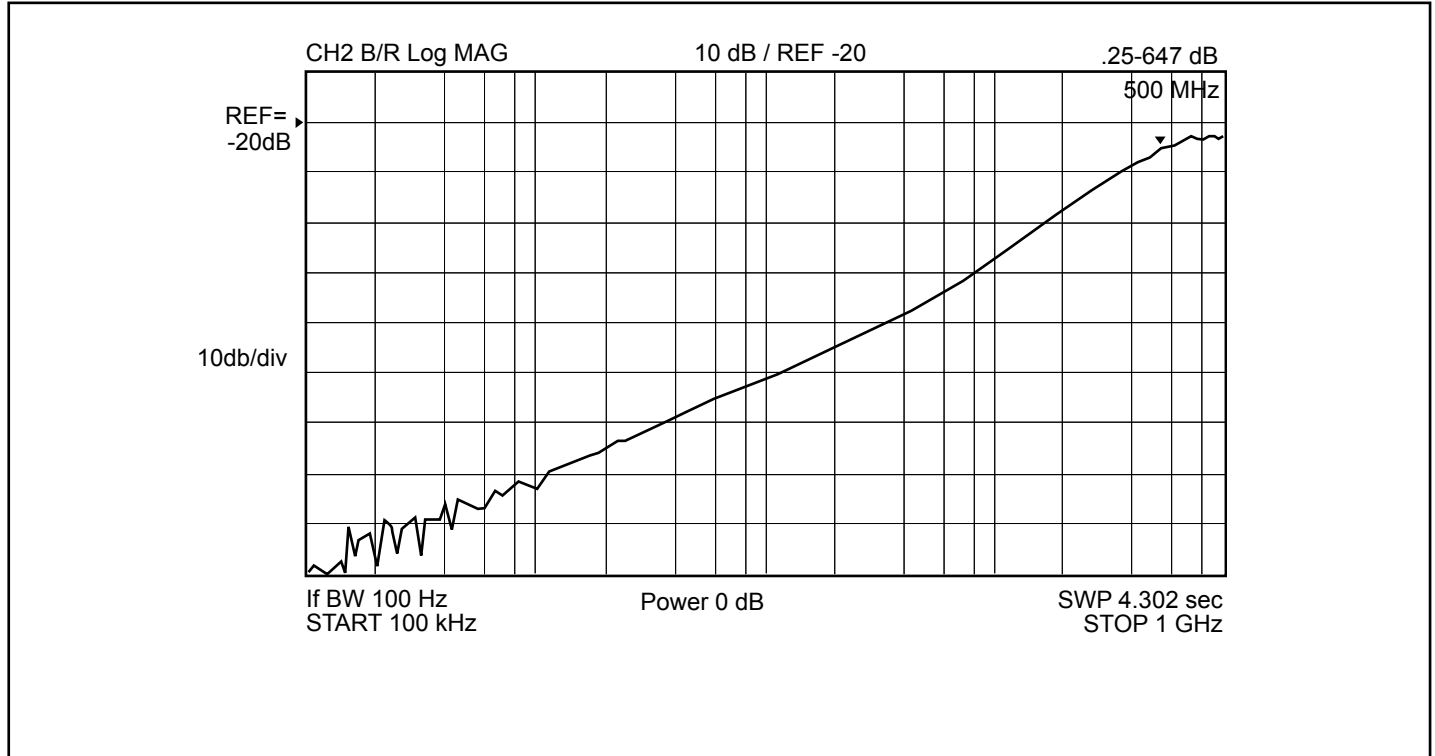

Switching Waveforms

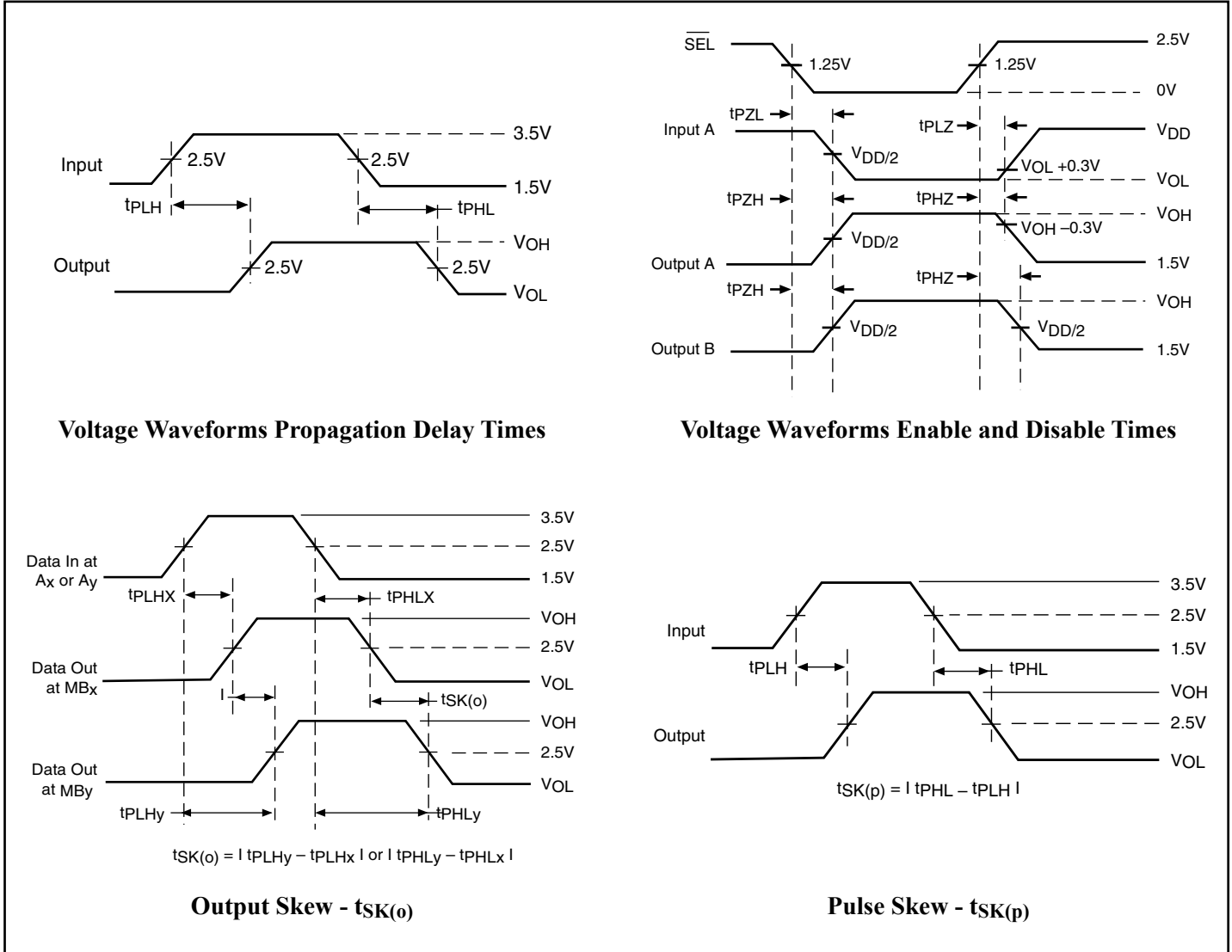

Applications Information

Logic Inputs

The logic control inputs can be driven up to +3.6V regardless of the supply voltage. For example, given a +3.3V supply, the output enables or select pins may be driven low to 0V and high to 3.6V. Driving IN Rail-to-Rail® minimizes power consumption.

Power-Supply Sequencing

Proper power-supply sequencing is advised for all CMOS devices. It is recommended to always apply V_{CC} before applying signals to the input/output or control pins.

Rail-to-Rail is a registered trademark of Nippon Motorola, Ltd

Packaging Mechanical: 24-pin QSOP (Q)

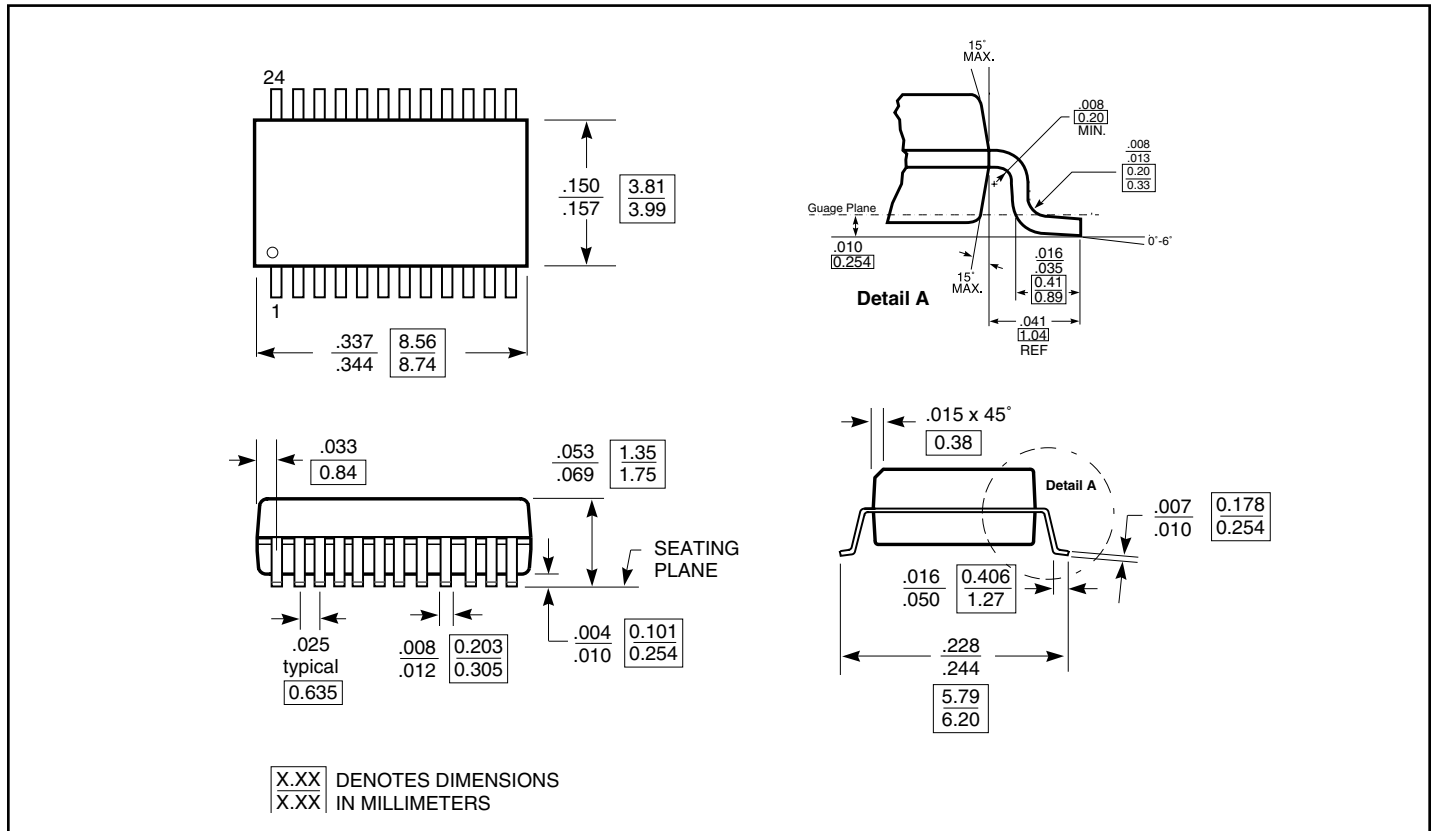

Ordering Information

Ordering Code	Package Code	Package Description
PI3V512Q	Q	24-pin 150 mil wide plastic QSOP
PI3V512QE	Q	Pb-free & Green, 24-pin 150 mil wide plastic QSOP

Notes:

1. Thermal characteristics can be found on the company web site at www.pericom.com/packaging/