



## PI5A121/PI5A122/PI5A124

### Wide Bandwidth Analog Switches

#### Features

- Single-Supply Operation (+2V to +6V)
- Rail-to-Rail Analog Signal Dynamic Range
- Low On-Resistance (6Ω typ. with 5V supply)  
Minimizes Distortion and Error Voltages
- On-Resistance Flatness, 3Ω typ.
- Low Charge Injection Reduces Glitch Errors. Q = 4pC typ.
- High Speed.  $t_{ON} = 10\text{ns}$  typ.
- Wide -3dB Bandwidth: 326 MHz (typ.)
- High-Current Channel Capability: >100mA
- TTL/CMOS Logic Compatible
- Low Power Consumption (0.5μW typ)
- Small outline transistor package minimizes board area
- Packaging (Pb-free & Green available):
  - 5-pin 65-mil wide SOT23 (T) for PI5A121 and PI5A122
  - 6-pin 65-mil wide SOT23 (T) for PI5A124
  - 5-pin 50-mil wide SC70 (C) for PI5A121/PI5A122

#### Applications

- Audio, Video Switching, and Routing
- Battery-Powered Communication Systems
- Computer Peripherals
- Telecommunications
- Portable Instrumentation
- Mechanical Relay Replacement
- Cell Phones
- PDAs

#### Description

The PI5A121/PI5A122/PI5A124 are analog switches designed for single-supply operation. These high-precision devices are ideal for low-distortion audio, video, signal switching and routing.

The PI5A121 is a single-pole throw (SPST) normally open (NO) switch. The switch is open when IN is LOW. The PI5A122 is a single-pole single-throw (SPST) normally closed (NC) switch.

Each switch conducts current equally well in either direction when on. When off, they block voltages up to V+.

These switches are fully specified with +5V, and +3.3V supplies. With +5V, they guarantee <10Ω On-Resistance. On-Resistance matching between channels is within 2Ω. On-Resistance flatness is less than 55Ω over the specified range. These switches also guarantee fast switching speeds ( $t_{ON} < 20\text{ns}$ ).

These products are available in 5-pin SC70 and/or 6-pin SOT23 plastic packages for operation over the industrial (-40°C to +85°C) temperature range.

#### Functional Diagrams, Pin Configurations and Truth Tables

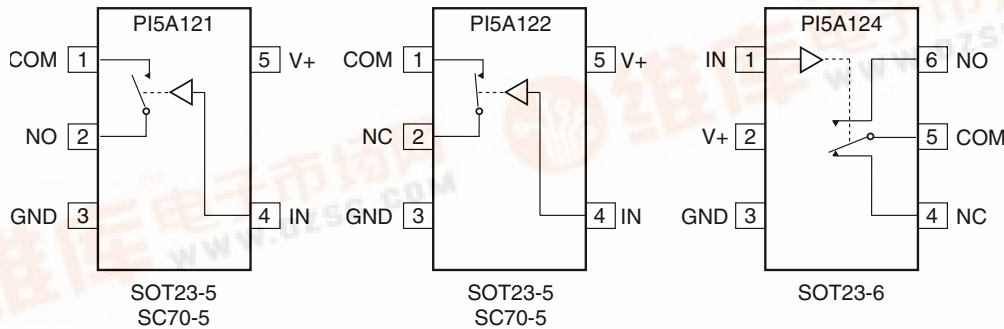

Switches shown for Logic "0" input

IN	PI5A121	PI5A122
0	OFF	ON
1	ON	OFF

LOGIC	PI5A124	
	NC	NO
0	ON	OFF
1	OFF	ON





### Absolute Maximum Ratings

Voltages Referenced to Gnd

V+ .....-0.5V to +7V

V<sub>IN</sub>, V<sub>COM</sub>, V<sub>NC</sub>, V<sub>NO</sub> (Note 1).....-0.5V to V<sub>CC</sub> +2V  
or 30mA, whichever occurs first

Current (any terminal)..... ±25mA

Peak Current, COM, NO, NC

(Pulsed at 1ms, 10% duty cycle)..... ±25mA

### Thermal Information

Continuous Power Dissipation

SOT23-6 (derate 7mW/°C above +70°C)..... 550mW

Storage Temperature .....-65°C to +150°C

Lead Temperature (soldering, 10s) ..... +300°C

#### Note 1:

Signals on NC, NO, COM, or IN exceeding V+ or GND are clamped by internal diodes. Limit forward diode current to 30mA.

**Caution:** Stresses beyond those listed under “Absolute Maximum Ratings” may cause permanent damage to the device. This is a stress only rating and operation of the device at these or any other conditions beyond those indicated in the operational sections of this specification is not implied.

### Electrical Specifications - Single +5V Supply

(V+ = +5V ± 10%, GND = 0V, V<sub>INH</sub> = 2.4V, V<sub>INL</sub> = 0.8V)

Parameter	Symbol	Conditions	Temp.(°C)	Min. <sup>(1)</sup>	Typ. <sup>(2)</sup>	Max. <sup>(1)</sup>	Units
<b>Analog Switch</b>							
Analog Signal Range <sup>(3)</sup>	V <sub>ANALOG</sub>		Full	0		V+	V
On-Resistance	R <sub>ON</sub>	V+ = 4.5V, I <sub>COM</sub> = -30mA, V <sub>NO</sub> or V <sub>NC</sub> = +2.5V	25		7.2	10	Ω
On-Resistance Match Between Channels <sup>(4)</sup>	ΔR <sub>ON</sub>		Full		0.2	2	
On-Resistance Flatness <sup>(5)</sup>	R <sub>FLAT(ON)</sub>	V+ = 5V, I <sub>COM</sub> = -30mA, V <sub>NO</sub> or V <sub>NC</sub> = 1V, 2.5V, 4V	25		2.72	3.5	
			Full			4	
NO or NC Off Leakage Current <sup>(6)</sup>	I <sub>NO(OFF)</sub> or I <sub>NC(OFF)</sub>	V+ = 5.5V, V <sub>COM</sub> = 0V, V <sub>NO</sub> or V <sub>NC</sub> = 4.5V	25		0.18		nA
			Full	-80		80	
COM Off Leakage Current <sup>(6)</sup>	I <sub>COM(OFF)</sub>	V+ = 5.5V, V <sub>COM</sub> = + 4.5V, V <sub>NO</sub> or V <sub>NC</sub> = ± 0V	25		0.20		
			Full	-80		80	
COM On Leakage Current <sup>(6)</sup>	I <sub>COM(ON)</sub>	V+ = 5.5V, V <sub>COM</sub> = +4.5V V <sub>NO</sub> or V <sub>NC</sub> = +4.5V	25		0.20		
			Full	-80		80	

**Electrical Specifications - Single +5V Supply (continued)**

 (V+ = +5V ± 10%, GND = 0V, V<sub>INH</sub> = 2.4V, V<sub>INL</sub> = 0.8V)

Parameter	Symbol	Conditions	Temp(°C)	Min. <sup>(1)</sup>	Typ. <sup>(2)</sup>	Max. <sup>(1)</sup>	Units
<b>Logic Input</b>							
Input High Voltage	V <sub>IH</sub>	Guaranteed logic High Level	Full	2			V
Input Low Voltage	V <sub>IL</sub>	Guaranteed logic Low Level				0.8	
Input Current with Voltage High	I <sub>INH</sub>	V <sub>IN</sub> = 2.4V, all others = 0.8V		-1	0.005	1	μA
Input Current with Voltage Low	I <sub>INL</sub>	V <sub>IN</sub> = 0.8V, all others = 2.4V		-1	0.005	1	
<b>Dynamic</b>							
Turn-On Time	t <sub>ON</sub>	V <sub>CC</sub> = 5V, Figure 1	25		7	15	ns
			Full			20	
Turn-Off Time	t <sub>OFF</sub>		25		1	7	
			Full			10	
Charge Injection <sup>(3)</sup>	Q	C <sub>L</sub> = 1nF, V <sub>GEN</sub> = 0V, R <sub>GEN</sub> = 0Ω, Figure 2	25		1.6	10	pC
Off Isolation	O <sub>IRR</sub>	R <sub>L</sub> = 50Ω, C <sub>L</sub> = 5pF, f = 10MHz, Figure 3			-43		dB
Crosstalk <sup>(8)</sup>	X <sub>TALK</sub>	R <sub>L</sub> = 50Ω, C <sub>L</sub> = 5pF, f = 10MHz, Figure 4			-43		
NC or NO Capacitance	C <sub>(OFF)</sub>	f = 1kHz, Figure 5			5.5		pF
COM Off Capacitance	C <sub>COM(OFF)</sub>				5.5		
COM On Capacitance	C <sub>COM(ON)</sub>			f = 1kHz, Figure 6		13	
-3dB Bandwidth	BW	R <sub>L</sub> = 50Ω, Figure 7		Full		326	
<b>Supply</b>							
Power-Supply Range	V+		Full	2		6	V
Positive Supply Current	I+	V <sub>CC</sub> = 5.5V, V <sub>IN</sub> = 0V or V+				1	μA

**Notes:**

- The algebraic convention, where most negative value is a minimum and most positive is a maximum, is used in this data sheet.
- Typical values are for DESIGN AID ONLY, not guaranteed or subject to production testing.
- Guaranteed by design
- ΔR<sub>ON</sub> = R<sub>ON max</sub> - R<sub>ON min</sub>
- Flatness is defined as the difference between the maximum and minimum value of On-Resistance measured.
- Leakage parameters are 100% tested at maximum rated hot temperature and guaranteed by correlation at +25°C.
- Off Isolation = 20log<sub>10</sub> [ V<sub>COM</sub> / (V<sub>NO</sub> or V<sub>NC</sub>) ]. See Figure 3.
- Between any two switches. See Figure 4.



**Electrical Specifications - Single +3.3V Supply**

(V+ = +3.3V ± 10%, GND = 0V, VINH = 2.4V, VINL = 0.8V)

Parameter	Symbol	Conditions	Temp.(°C)	Min.(1)	Typ.(2)	Max.(1)	Units
<b>Analog Switch</b>							
Analog Signal Range <sup>(3)</sup>	V <sub>ANALOG</sub>			0		V+	V
On-Resistance	R <sub>ON</sub>	V+ = 3V, I <sub>COM</sub> = -30mA, V <sub>NO</sub> or V <sub>NC</sub> = 1.5V	25		12	18	Ω
			Full			22	
On-Resistance Match Between Channels <sup>(4)</sup>	ΔR <sub>ON</sub>	V+ = 3.3V, I <sub>COM</sub> = -30mA, V <sub>NO</sub> or V <sub>NC</sub> = 0.8V, 2.5V	25		1	1	
			Full			2	
On-Resistance Flatness <sup>(3,5)</sup>	R <sub>FLAT(ON)</sub>	V+ = 3.3V, I <sub>COM</sub> = -30mA, V <sub>NO</sub> or V <sub>NC</sub> = 0.8V, 2.5V	25		0.5	4	
			Full			5	
<b>Dynamic</b>							
Turn-On Time	t <sub>ON</sub>	V+ = 3.3V, V <sub>NO</sub> or V <sub>NC</sub> = 1.5V, Figure 1	25		15	25	ns
			Full			40	
Turn-Off Time	t <sub>OFF</sub>	V+ = 3.3V, V <sub>NO</sub> or V <sub>NC</sub> = 1.5V, Figure 1	25		1.5	12	
			Full			20	
Charge Injection <sup>(3)</sup>	Q	C <sub>L</sub> = 1nF, V <sub>GEN</sub> = 0V, R <sub>GEN</sub> = 0V, Figure 2	25		1.3	10	pC
<b>Supply</b>							
Positive Supply Current	I+	V+ = 3.6V, V <sub>IN</sub> = 0V or V+ All Channels on or off	Full			1	μA
<b>Logic Input</b>							
Input High Voltage	V <sub>IH</sub>	Guaranteed logic high level	Full	2			V
Input Low Voltage	V <sub>IL</sub>	Guaranteed logic low level	Full			0.8	
Input High Current	I <sub>INH</sub>	V <sub>IN</sub> = 2.4V, all others = 0.8V	Full	-1		1	μA
Input Low Current	I <sub>INL</sub>	V <sub>IN</sub> = 0.8V, all others = 2.4V	Full	-1		1	

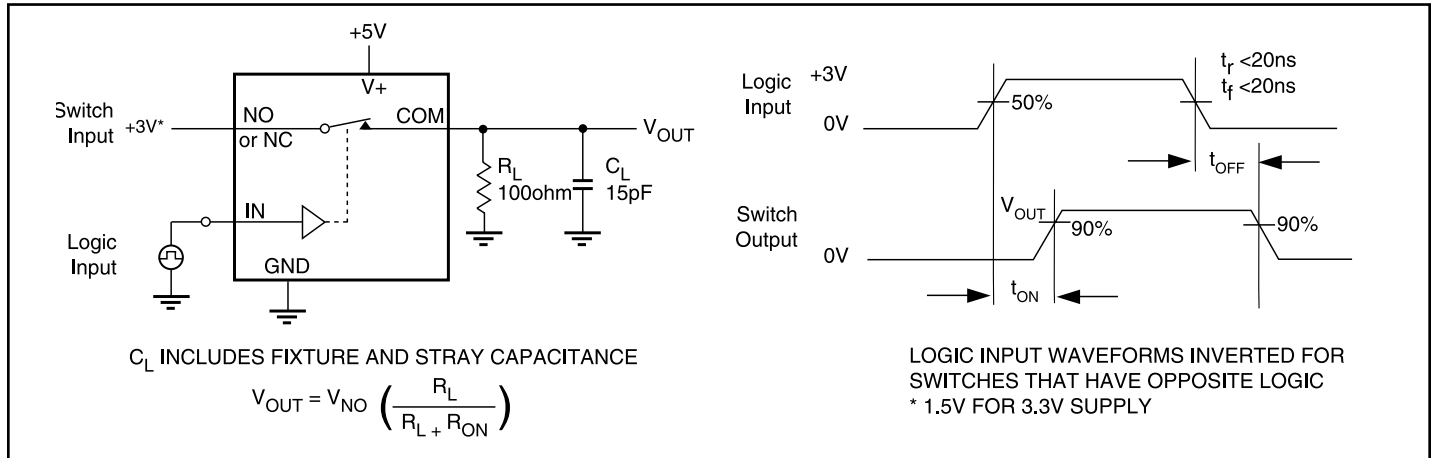
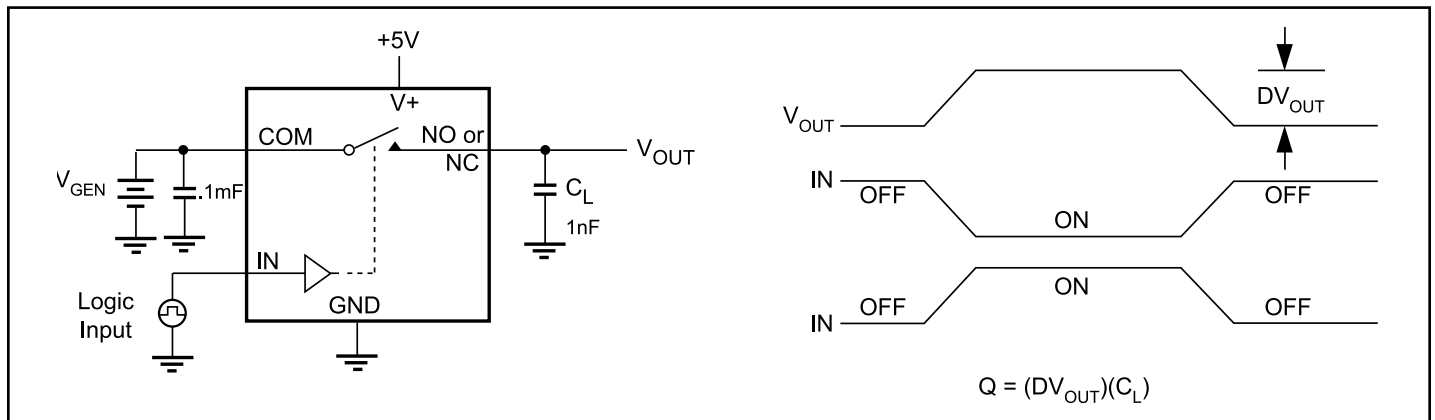
**Test Circuits/Timing Diagrams**

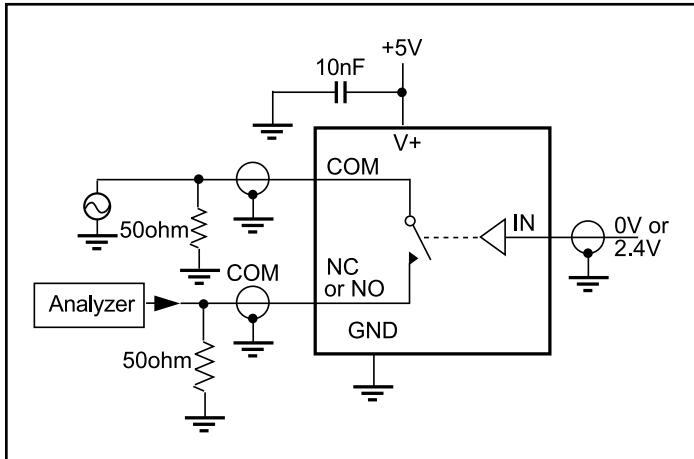
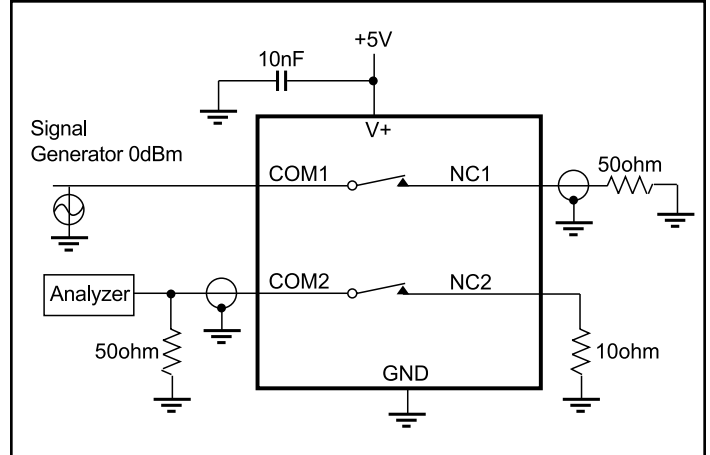
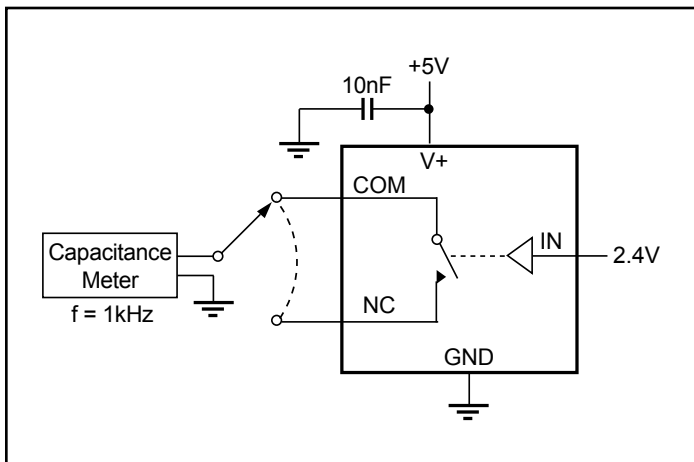
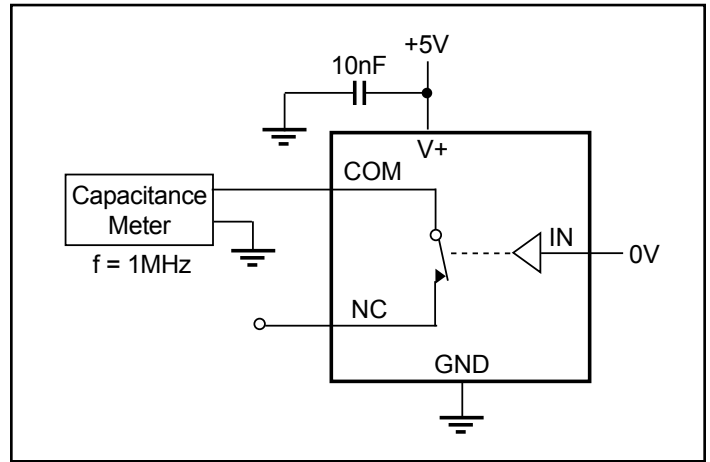
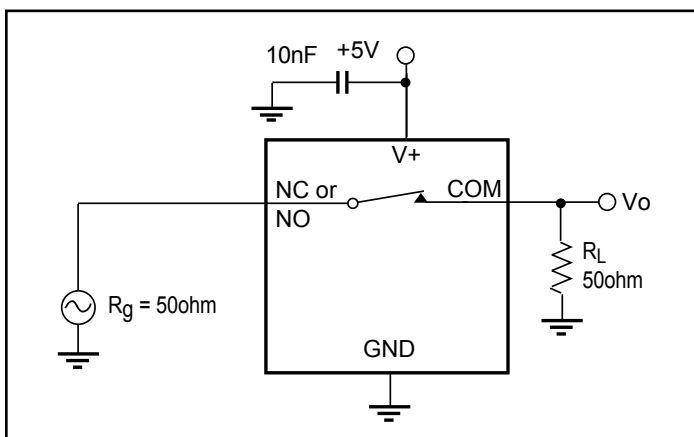
**Figure 1. Switching Time**

**Figure 2. Charge Injection**

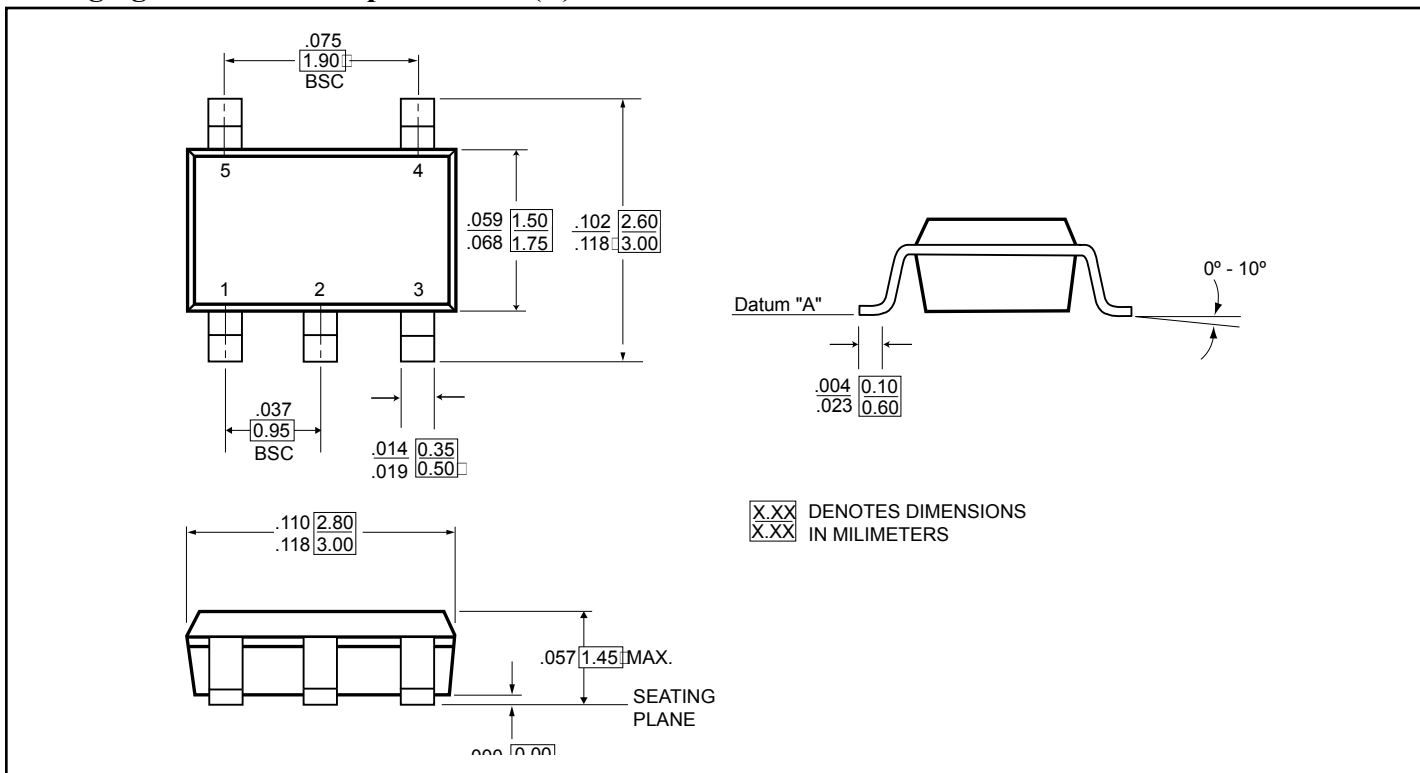
**Test Circuits/Timing Diagrams (continued)**

**Figure 3. Off Isolation**

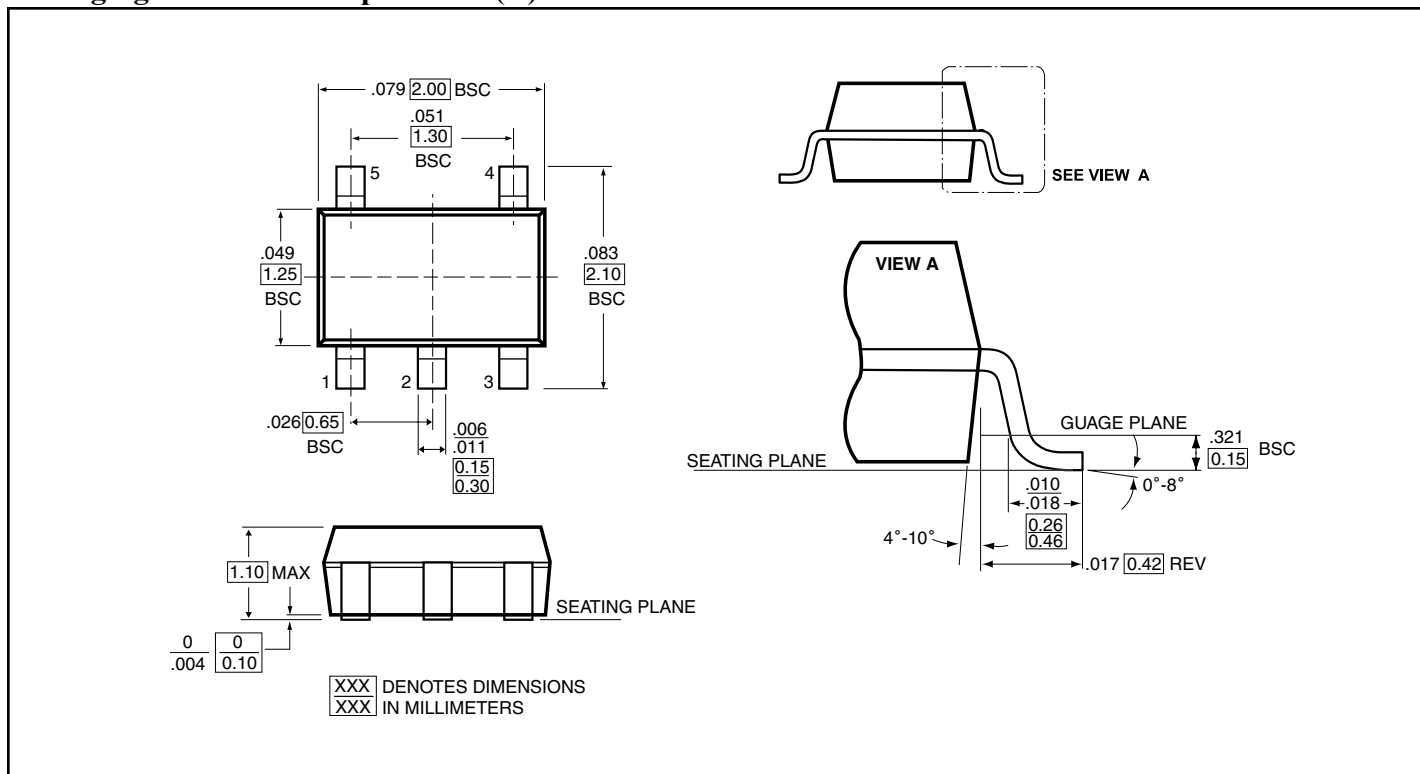
**Figure 4. Crosstalk (124 only)**

**Figure 5. Channel-Off Capacitance**

**Figure 6. Channel-On Capacitance**

**Figure 7. Bandwidth**

**Packaging Mechanical: 5-pin SOT-23 (T)**



**Packaging Mechanical: 5-pin SC70 (C)**



Packaging Mechanical: 6-pin SOT-23 (T)

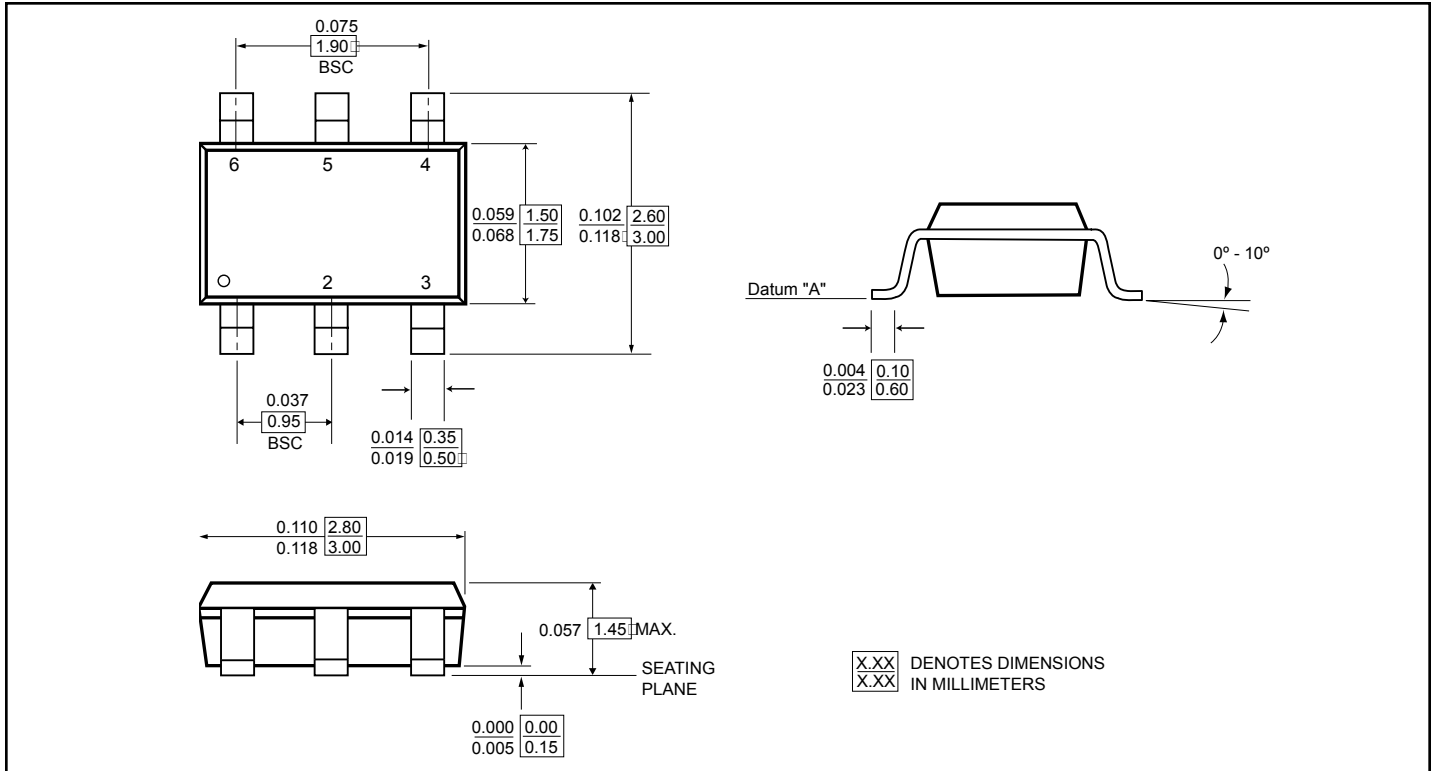

Ordering Information

Ordering Code	Packaging Code	Package Type	Top Marking
PI5A121TX	T	5-pin, 65-mil wide SOT-23	ZV
PI5A121TEX	T	Pb-free & Green, 5-pin, 65-mil wide SOT-23	Z̄V
PI5A121CX	C	5-pin, 50-mil wide SOT-23	ZV
PI5A121CEX	C	Pb-free & Green, 5-pin, 50-mil wide SOT-23	Z̄V
PI5A122TX	T	5-pin, 65-mil wide SOT-23	ZU
PI5A122TEX	T	Pb-free & Green, 5-pin, 65-mil wide SOT-23	Z̄U
PI5A122CX	C	5-pin, 50-mil wide SOT-23	ZU
PI5A122CEX	C	Pb-free & Green, 5-pin, 50-mil wide SOT-23	Z̄U
PI5A124TX	T	6-pin, 65-mil wide SOT-23	ZT
PI5A124TEX	T	Pb-free & Green, 6-pin, 65-mil wide SOT-23	Z̄T

Notes:

1. Thermal characteristics can be found on the company web site at [www.pericom.com/packaging/](http://www.pericom.com/packaging/)
2. X = Tape/Reel