



PI5A4594A/4595A/4596A/4597A

SOTINY™ Low-Voltage, Single-Supply, 8-Ohm SPST CMOS Analog Switches

Features

- 8-ohm max. On-Resistance
- 1.0-ohm max. On-Resistance Flatness
- Fast Switching
 $t_{ON} = 28\text{ns max.}$
 $t_{OFF} = 35\text{ns max.}$
- Guaranteed 5pC max. Charge Injection
- +2.0V to +5.5V Single-Supply Operation
- 300 MHz -3dB Bandwidth at +25°C
- TTL/CMOS-Logic Compatible
- 80dB Off-Isolation at 1MHz
- 0.5nA max. Off-Leakage
- 0.05% THD
- Packaging (Pb-free & Green available):
 - 5-pin SC70 (C)

Description

PI5A4594A/PI5A4596A are single-pole/single-throw (SPST) analog switches that operate from a single +2.0V to +5.5V supply. The PI5A4594A/PI5A4596A switches are normally open (NO), and the PI5A4595A/PI5A4597A are normally closed (NC). The PI5A4596A/PI5A4597A pinouts are optimized for the highest SC70 package off-isolation available.

These switches have 10-ohm max On-Resistance (R_{ON}), with 1.5-ohms max R_{ON} flatness over the analog signal range when powered from a +5V supply. Leakage currents are 0.5nA and fast switching times are less than 40ns. They are packaged in a compact 5-pin SC70 package.

Applications

- Cellular Phones • Communications Circuits
- Battery-Operated Equipment • DSL Modems
- Audio and Video Signal Routing • PCMCIA Cards

Block Diagrams/Pin Configurations/Truth Table

Top Views

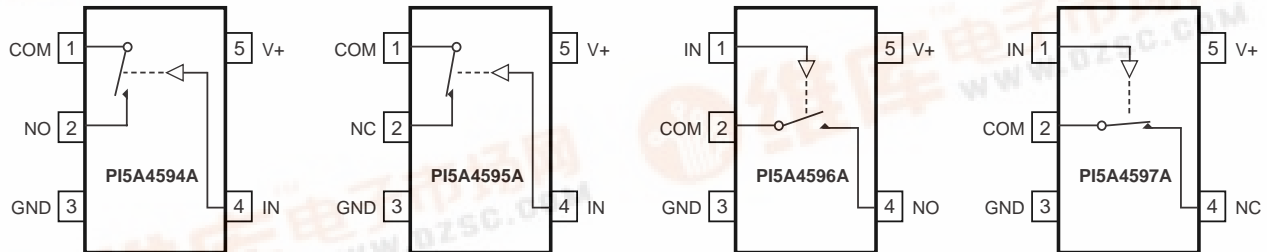

Switches shown for Logic "0" input.

Input	Switch State	
	PI5A4594A/PI5A4596A	PI5A4595A/PI5A4597A
LOW	OFF	ON
HIGH	ON	OFF

Pin Description

Pin				Name	Function
PI5A4594A	PI5A4595A	PI5A4596A	PI5A4597A		
1	1	2	2	COM	Analog Switch, Common
2	-	4	-	NO	Analog Switch, Normally Open
3	3	3	3	GND	Ground
4	4	1	1	IN	Digital Control Input
5	5	5	5	V+	Positive Supply Voltage
	2	-	4	NC	Analog Switch, Normally Closed

Note: NO, NC, and COM pins are identical and interchangeable. Any pin may be considered as an input or an output; signals pass



PI5A4594A/4595A/4596A/4597A
SOT1N Low-Voltage, Single-Supply,
8-Ohm SPST CMOS Analog Switches

Absolute Maximum Ratings

Voltages Referenced to GND		Continuous Power Dissipation (T _A = +70°C)
V ₊	-0.3V to +6V	5-Pin SC70 (derate 3.1mW/°C above +70°C) 247mW
Voltage into Any Terminal (Note 1)	-0.3V to (V ₊ +0.3V)	Operating Temperature Range
Continuous Current into Any Terminal	±20mA	PI5A459_EXK -40°C to +85°C
Peak Current, NO, NC, or COM		Storage Temperature Range -65°C to +150°C
(pulsed at 1ms, 10% duty cycle)	±40mA	Lead Temperature (soldering, 10s) +300°C

Note
 1. Voltages exceeding V₊ or GND on any signal terminal are clamped by internal diodes. Limit forward-diode current to maximum current rating.

Stresses beyond those listed under “Absolute Maximum Ratings” may cause permanent damage to the device. These are stress ratings only, and functional operation of the device at these or any other conditions beyond those indicated in the operational sections of the specifications is not implied. Exposure to absolute maximum rating conditions for extended periods may affect device reliability.

Electrical Characteristic - +5V Supply (V₊ = +4.5V to +5.5V, V_{IH} = +2.4V, V_{IL} = +0.8V, T_A = T_{MIN} to T_{MAX}, unless otherwise noted. Typical values are at V₊ = +5V, T_A = +25°C.)^(2,3)

Parameter	Symbol	Conditions	Min.	Typ.	Max.	Units	
Analog Switch							
Analog Signal Range	V _{COM} , V _{NO} , V _{CNC}		0		V ₊	V	
On Resistance	R _{ON}	V ₊ = 4.5V, V _{NO} , or V _{NC} = 3.5V, I _{COM} = 10mA	T _A = +25V	5	8	Ω	
			T _A = T _{MIN} to T _{MAX}		10		
On-Resistance Flatness ⁽⁴⁾	R _{FLAT (ON)}	V _{NO} or V _{NC} = 1.5V, 2.5V, 3.5V; V ₊ = 4.5V; I _{COM} = 10mA	T _A = +25V	0.5	1.0	Ω	
			T _A = T _{MIN} to T _{MAX}		1.5		
NO or NC Off Leakage Current	I _{NO (OFF)} I _{NO (OFF)}	V ₊ = 5.5V; V _{COM} = 1V, 4.5V; V _{NO} or V _{NC} = 4.5V, 1V	T _A = +25V	-0.5	0.01	0.5	nA
			T _A = T _{MIN} to T _{MAX}	-5		5	
COM-Off Leakage Current	I _{COM (OFF)}	V ₊ = 5.5V; V _{COM} = 1V, 4.5V; V _{NO} or V _{NC} = 4.5V, 1V	T _A = +25V	-0.5	0.01	0.5	nA
			T _A = T _{MIN} to T _{MAX}	-5		5	
COM On Leakage Current	I _{COM (ON)}	V ₊ = 5.5V; V _{COM} = 1V, 4.5V; V _{NO} or V _{NC} = 1V, 4.5V, or floating	T _A = +25V	-1	0.01	1	nA
			T _A = T _{MIN} to T _{MAX}	-10		10	
Digital I/O							
Input Logic High	V _{IH}		2.4			V	
Input Logic Low	V _{IH}				0.8		
Input Logic Current	I _{IH} , I _{IL}	V _{IN} = V ₊ , 0	-1		1	μA	
Dynamic							
Turn-On Time	t _{ON}	V _{NO} or V _{NC} = 3V, R _L = 300 ohms, C _L = 35pF, Figure 3	T _A = +25V	20	28	ns	
			T _A = T _{MIN} to T _{MAX}		38		
Turn-Off Time	t _{OFF}	V _{NO} or V _{NC} = 3V, R _L = 300 ohms, C _L = 35pF, Figure 3	T _A = +25V	25	35	ns	
			T _A = T _{MIN} to T _{MAX}		42		
On-Channel -3dB Bandwidth	BW	Signal = 0dBm, 50 ohms in and out, Figure 4	T _A = +25V	300		MHz	



Electrical Characteristic - +5V Supply (continued) – (Typical values are at $V_+ = +5V$, $T_A = +25^\circ C$.)^(2,3)

($V_+ = +4.5V$ to $+5.5V$, $V_{IH} = +2.4V$, $V_{IL} = +0.8V$, $T_A = T_{MIN}$ to T_{MAX} , unless otherwise noted.)

Parameter	Symbol	Conditions	Min.	Typ.	Max.	Units
Charge Injection ⁽⁵⁾	Q	V_{NO} or $V_{NC} = 0$, $C_L = 1nF$, Fig. 2	$T_A = +25^\circ C$		2	5 pC
Off Isolation ⁽⁶⁾	V_{ISO}	V_{NO} or $V_{NC} = 1V_{RMS}$, $R_L = 50$ ohms, $C_L = 5pF$, $f = 1MHz$, Fig. 4	$T_A = +25^\circ C$	PI5A4594/ PI5A4595	80	dB
				PI5A4596/ PI5A4597	83	
NO or NC Off Capacitance	$C_{NO(OFF)}$, $C_{NC(OFF)}$	V_{NO} or $V_{NC} = 0$, $f = 1MHz$, Fig. 5	$T_A = +25^\circ C$		8	pF
COM Off Capacitance	$C_{COM(OFF)}$	$V_{COM} = 0V$, $f = 1MHz$, Fig. 5	$T_A = +25^\circ C$		8	
COM On Capacitance	$C_{COM(ON)}$	$V_{COM} = 0V$, $f = 1MHz$, Fig. 5	$T_A = +25^\circ C$		20	
Total Harmonic Distortion Plus Noise	THD	$V = 5V_{p-p}$, $R_L = 600$ ohms, $f = 20Hz$ to $20kHz$	$T_A = +25^\circ C$		0.2	%
Power Supply						
Power-Supply Range	V_+		2.0		5.5	V
V_+ Supply Current	I_+	$V_+ = 5.5V$, $V_{IN} = 0$ or V_+	$T_A = T_{MIN}$ to T_{MAX}		1	μA

Electrical Characteristics - Single 3V Supply ($V_+ = +3V \pm 10\%$, $V_- = 0V$, $GND = 0V$, $V_{AH} = V_{IH} = +2.0V$, $V_{AL} = V_{IL} = +0.5V$)

Parameter	Symbol	Conditions	Min.	Typ.	Max.	Units	
Analog Switch							
Analog Signal Range ⁽³⁾	V_{COM} , V_{NO} , V_{NC}		0		V_+	V	
On-Resistance	R_{ON}	V_{NO} or $V_{NC} = 1.5V$, $I_{COM} = 10mA$, $V_+ = 2.7V$	$T_A = +25^\circ C$		15	Ω	
			$T_A = T_{MIN}$ to T_{MAX}		20		
Digital I/O							
Inut Logic High	V_{IH}		2.0			V	
Input Logic Low	V_{IL}				0.8		
Input Logic Current	I_{IH} , I_{IL}	$V_{IN} = V_+$, 0	-1	0.03	1	μA	
Dynamic							
Turn-On Time	t_{ON}	V_{NO} or $V_{NC} = 2V$, $R_L = 300\Omega$, $C_L = 35pF$, Fig.3	$T_A = +25^\circ C$		25	45	ns
			$T_A = T_{MIN}$ to T_{MAX}			55	
Turn-Off Time	t_{OFF}	V_{NO} or $V_{NC} = 2V$, $R_L = 300\Omega$, $C_L = 35pF$, Fig.3	$T_A = +25^\circ C$		30	50	
			$T_A = T_{MIN}$ to T_{MAX}			60	
Charge Injection ⁽⁵⁾	Q	V_{NO} or $V_{NC} = 0$, $C_L = 1nF$, Fig. 2	$T_A = +25^\circ C$		2	4 pC	
Power Supply							
V_+ Supply Current	I_+	$V_+ = 3.6$, $V_{IN} = 0$ or V_+	$T_A = T_{MIN}$ to T_{MAX}		1	μA	

Notes:

- Parameters are 100% tested at $+25^\circ C$ only, and guaranteed by correlation at the full-rated temperature.
- Algebraic convention is used in this data sheet; the most negative value is shown in the minimum column.
- Flatness: the difference between maximum & minimum values of ON-resistance measured over specified analog signal ranges.
- Guaranteed by design.
- Off-Isolation = $20 \log_{10} (V_{COM} / V_{NO})$, V_{COM} = output, V_{NO} = input to off switch.

Applications Information

Analog Signal Levels

Analog signals can range over the supply voltage ($V+$ to GND) with ON-resistance changing very little over the entire range. The PI5A4594A–PI5A4597A are bidirectional, so the NO, NC, and COM pins can be used either as inputs or outputs.

Test Circuits/Timing Diagrams

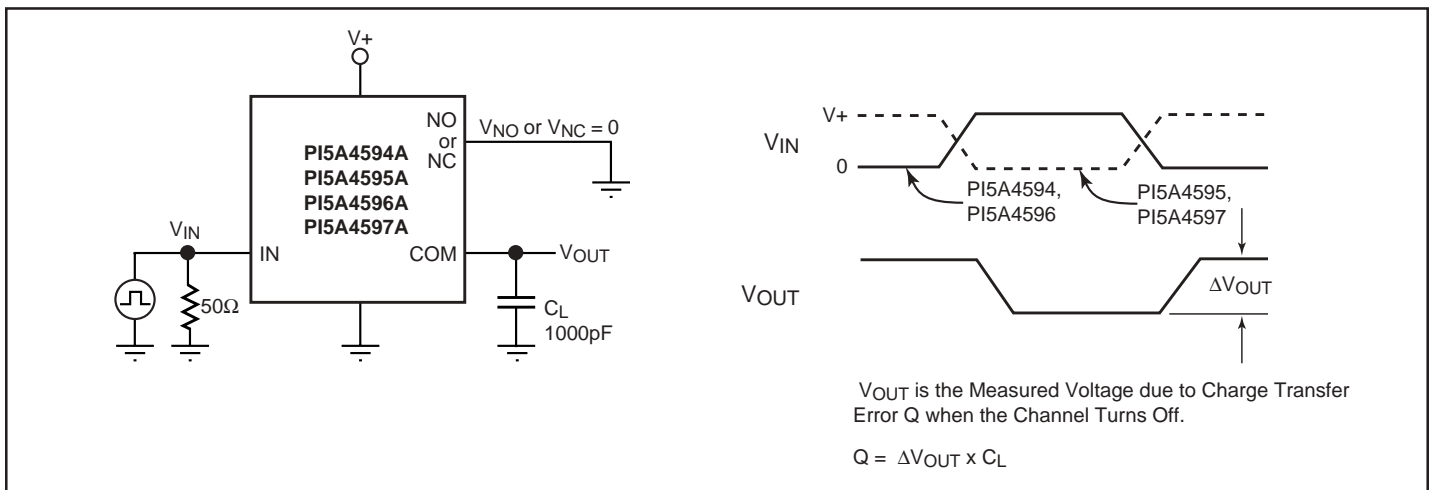

Figure 2. Charge Injection

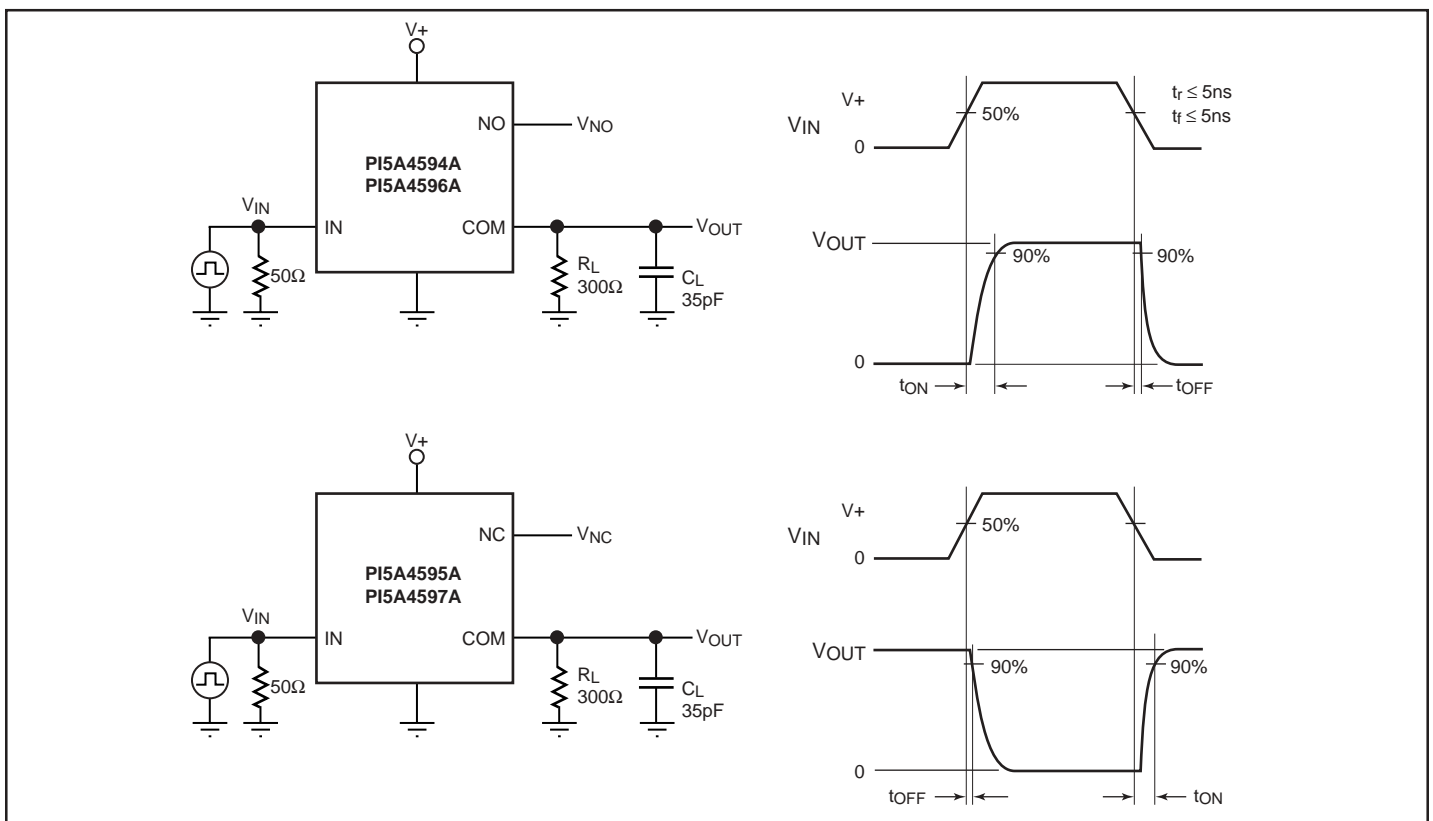

Figure 3. Switching Times

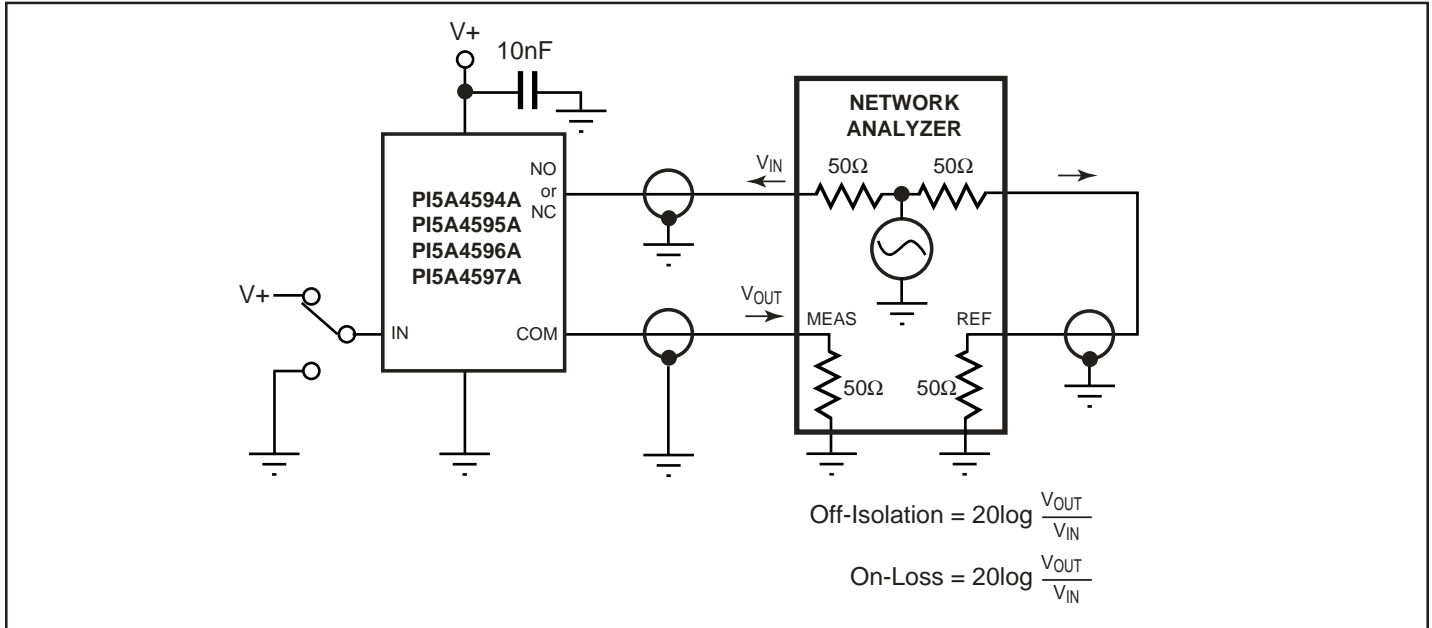

Figure 4. Off-Isolation and On-Channel Bandwidth

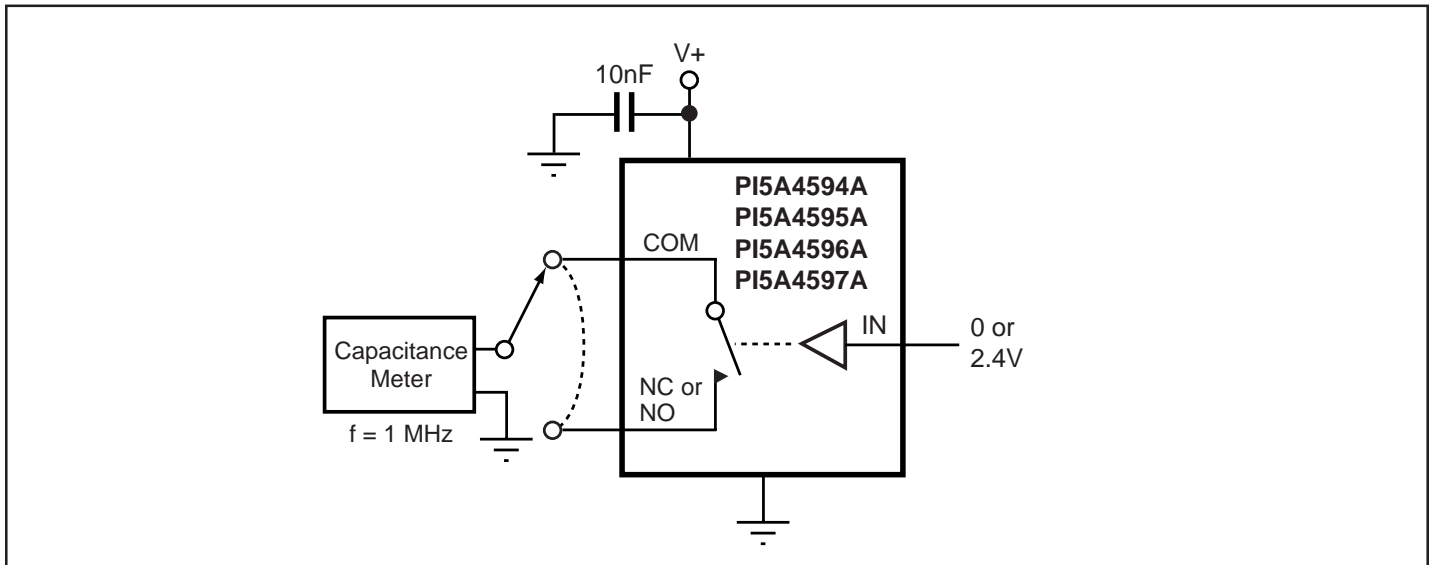
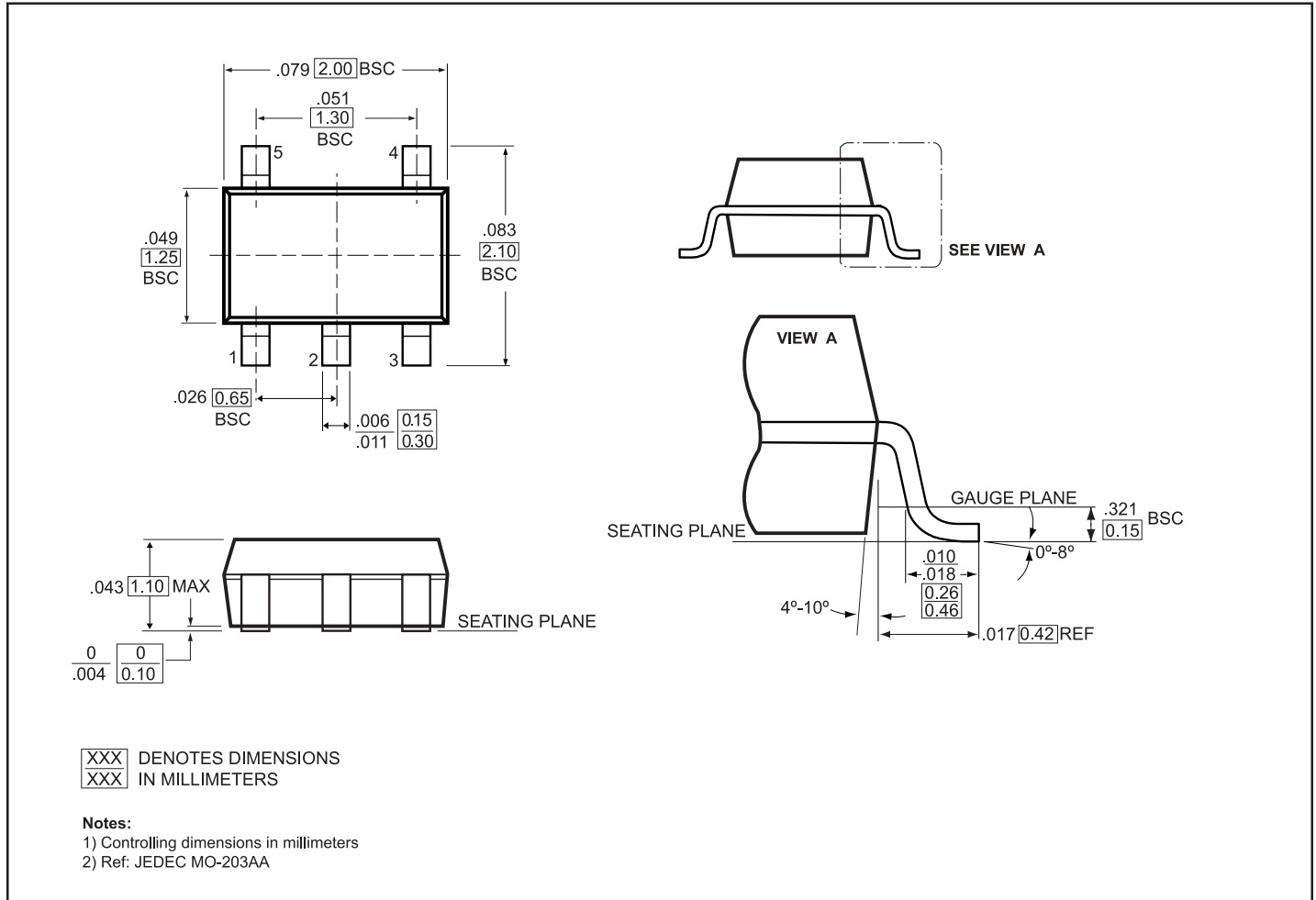

Figure 5. Channel On-/Off Capacitance



Packaging Mechanical: 5-Pin SC70 (C)



Ordering Information

Ordering Code	Package Code	Package Description	Top Marking
PI5A4594ACX	C	5-pin SC70	ZR
PI5A4594ACEX	C	Pb-free & Green, 5-pin SC70	$\bar{Z}R$
PI5A4595ACX	C	5-pin SC70	ZQ
PI5A4595ACEX	C	Pb-free & Green, 5-pin SC70	$\bar{Z}Q$
PI5A4596ACX	C	5-pin SC70	ZP
PI5A4596ACEX	C	Pb-free & Green, 5-pin SC70	$\bar{Z}P$
PI5A4597ACX	C	5-pin SC70	ZO
PI5A4597ACEX	C	Pb-free & Green, 5-pin SC70	$\bar{Z}O$

Notes:

1. Thermal characteristics can be found on the company web site at www.pericom.com/packaging/
2. X = Tape and reel