



PI5C16212

24-Bit Bus Exchange Switch

Product Features

- Near-Zero propagation delay
- 5-ohm switches connect inputs to outputs
- Direct bus connection when switches are ON
- Ultra-low quiescent power (0.1µA typical)
 - Ideally suited for notebook applications
- Industrial operating temperature: -40°C to +85°C
- Packaging (Pb-free & Green available):
 - 56-pin 240-mil wide thin plastic TSSOP (A)
 - 56-pin 300-mil wide plastic SSOP (V)
 - 56-pin 173-mil wide plastic TVSOP (K)

Product Description

Pericom Semiconductor's PI5C16212 is a 24-bit bus exchange switches designed with a low On-Resistance allowing inputs to be connected directly to outputs. This device operates as a 24-bit bus switch or a 12-bit exchanger that provides data exchanging between the four signal ports via the data select pins (S0-S2).

Logic Block Diagram

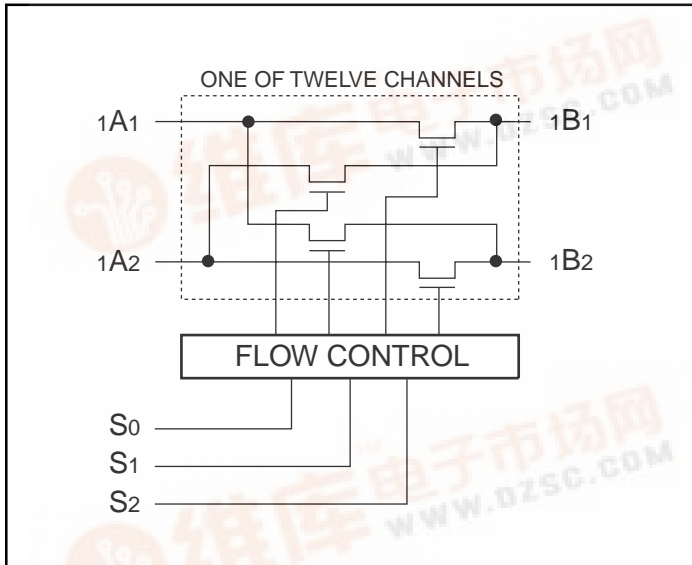

Product Pin Configuration

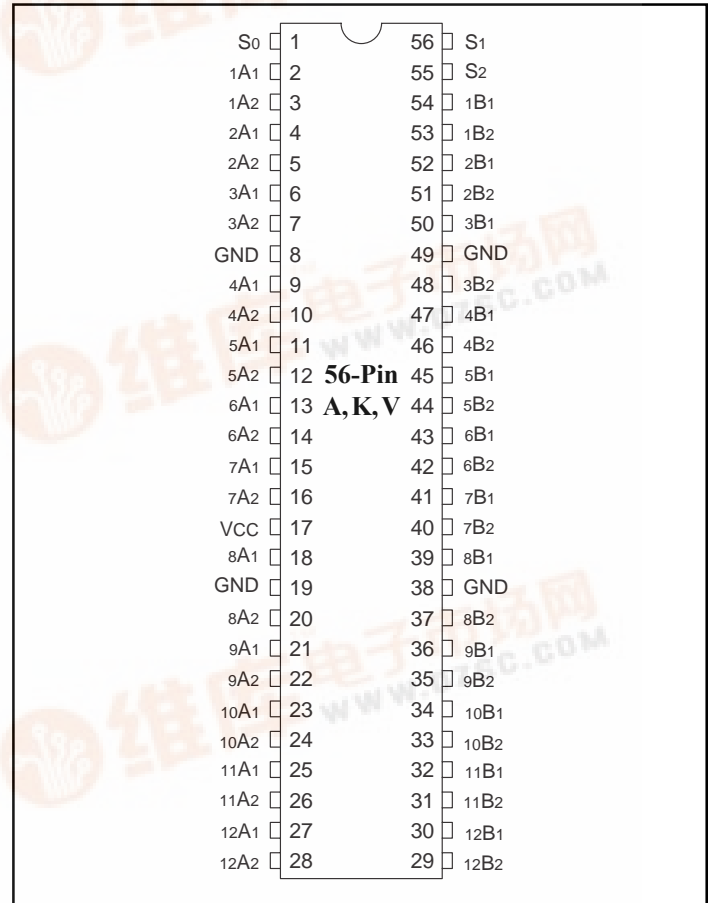

Truth Table

Function	S2	S1	S0	A1	A2
Disconnect	L	L	L	Z	Z
A1 to B1	L	L	H	B1	Z
A1 to B2	L	H	L	B2	Z
A2 to B1	L	H	H	Z	B1
A2 to B2	H	L	L	Z	B2
Disconnect	H	L	H	Z	Z
A1 to B1, A2 to B2	H	H	L	B1	B2
A1 to B2, A2 to B1	H	H	H	B2	B1

Note: H = High Voltage Level, L = Low Voltage Level, Z = High Impedance

Product Pin Description

Pin Name	I/O	Description
S0-S2	I	Select Inputs
xAx	I/O	Bus A
xBx	I/O	Bus B



Maximum Ratings

(Above which the useful life may be impaired. For user guidelines, not tested.)

Storage Temperature	-65°C to +150°C
Ambient Temperature with Power Applied	-40°C to +85°C
Supply Voltage to Ground Potential	-0.5V to +7.0V
DC Input Voltage	-0.5V to +7.0V
DC Output Current	120mA
Power Dissipation	1W

Note:

Stresses greater than those listed under MAXIMUM RATINGS may cause permanent damage to the device. This is a stress rating only and functional operation of the device at these or any other conditions above those indicated in the operational sections of this specification is not implied. Exposure to absolute maximum rating conditions for extended periods may affect reliability.

Recommended Operating Condition

Parameter	Description	Min.	Max.	Units
V _{CC}	Supply Voltage	4	5.5	V
V _{IH}	High-Level Input Voltage	2	—	
V _{IL}	Low-Level Input Voltage	—	0.8	
T _A	Operating Free-Air Temperature	-40	85	°C

DC Electrical Characteristics (Over the Operating Range, T_A = -40°C to +85°C, V_{CC} = 5V ± 10%)

Parameters	Description	Test Conditions ⁽¹⁾	Min.	Typ ⁽²⁾	Max.	Units
V _{IH}	Input HIGH Voltage	Guaranteed Logic HIGH Level	2.0	—	—	V
V _{IL}	Input LOW Voltage	Guaranteed Logic LOW Level	-0.5	—	0.8	
I _I	Input Current	V _{CC} = Max., V _{IN} = V _{CC} or GND	—	—	±1	µA
		V _{CC} = 0, V _{IN} = V _{CC}	—	—	10	
I _{OZH}	High Impedance Output Current	0 - A, B - V _{CC}	—	—	±1	
V _{IK}	Clamp Diode Voltage	V _{CC} = Min., I _{IN} = -18mA	—	-0.7	-1.2	V
I _{OS}	Short Circuit Current ⁽³⁾	A (B) = 0V, B (A) = V _{CC}	100	—	—	mA
V _H	Input Hysteresis at Control Pins		—	150	—	mV
R _{ON}	Switch On Resistance ⁽⁴⁾	V _{CC} = Min., V _{IN} = 0.0V, I _{ON} = 64mA	20	28	40	Ω
		V _{CC} = Min., V _{IN} = 2.4V, I _{ON} = 15mA	—	—	12	
			20	35	48	

Capacitance (T_A = 25°C, f = 1 MHz)

Parameters ⁽⁵⁾	Description	Test Conditions	Typ.	Max.	Units
C _{IN}	Input Capacitance	V _{IN} = 0V	3	6	pF
C _{OFF}	A/B Capacitance, Switch Off	V _{IN} = 0V	6	14	
C _{ON}	A/B Capacitance, Switch On	V _{IN} = 0V	12	30	

Notes:

1. For Max. or Min. conditions, use appropriate value specified under Electrical Characteristics for the applicable device.
2. Typical values are at V_{CC} = 5.0V, T_A = 25°C ambient and maximum loading.
3. Not more than one output should be shorted at one time. Duration of the test should not exceed one second.
4. Measured by the voltage drop between A and B pin at indicated current through the switch. On-Resistance is determined by the lower of the voltages on the two (A,B) pins.
5. This parameter is determined by device characterization but is not production tested.

Power Supply Characteristics

Parameters	Description	Test Conditions ⁽¹⁾		Min.	Typ. ⁽²⁾	Max.	Units
I _{CC}	Quiescent Power Supply Current	V _{CC} = Max.	V _{IN} = GND or V _{CC}	—	0.1	3.0	μA
ΔI _{CC} ⁽³⁾	Supply Current per Input @ TTL HIGH	V _{CC} = 5.5V	V _{IN} = 3.4V ⁽⁴⁾	—	—	0.2	mA
I _{CCD}	Supply Current per Input per MHz ⁽⁵⁾ S _N = GND, Control Input Toggling 50% Duty Cycle	V _{CC} = Max., A & B Pins Open		—	—	0.25	mA/ MHz

Notes:

1. For conditions shown as Max. or Min., use appropriate value specified under Electrical Characteristics for applicable device.
2. Typical values are at V_{CC} = 5.0V, +25°C ambient.
3. This is the increase in supply current for each input that is at the specified TTL voltage level rather than V_{CC} or GND.
4. Per TTL driven input (V_{IN} = 2.7V, control inputs only); A and B pins do not contribute to I_{CC}.
5. This current applies to the control inputs only and represent the current required to switch internal capacitance at the specified frequency. The A and B inputs generate no significant AC or DC currents as they transition. This parameter is not tested, but is guaranteed by design.

PI5C16212 Switching Characteristics over Operating Range

Parameters	Description	Conditions ⁽¹⁾	PI5C16212		Units
			Com.		
			Min.	Max.	
t _{PLH} t _{PHL}	Propagation Delay ^(2,3) , xAx to xBx, xBx to xAx	C _L = 50pF R _L = 500 ohms	—	0.25	ns
t _{PLH} t _{PHL}	Propagation Delay, S to Ax or Bx		1.5	7.5	
t _{PZH} t _{PZL}	Bus Enable Time, S to xAx or xBx		1.5	7.0	
t _{PHZ} t _{PLZ}	Bus Disable Time, S to xAx or xBx		1.5	6.5	

Notes:

1. See test circuit and waveforms.
2. This parameter is guaranteed but not tested on Propagation Delays.
3. The bus switch contributes no propagational delay other than the RC delay of the On-Resistance of the switch and the load capacitance. The time constant for the switch alone is of the order of 0.25ns for 50pF load. Since this time constant is much smaller than the rise/fall times of typical driving signals, it adds very little propagational delay to the system. Propagational delay of the bus switch when used in a system is determined by the driving circuit on the driving side of the switch and its interaction with the load on the driven side.

56-Pin 173-Mil Wide Plastic TVSOP (K) Package

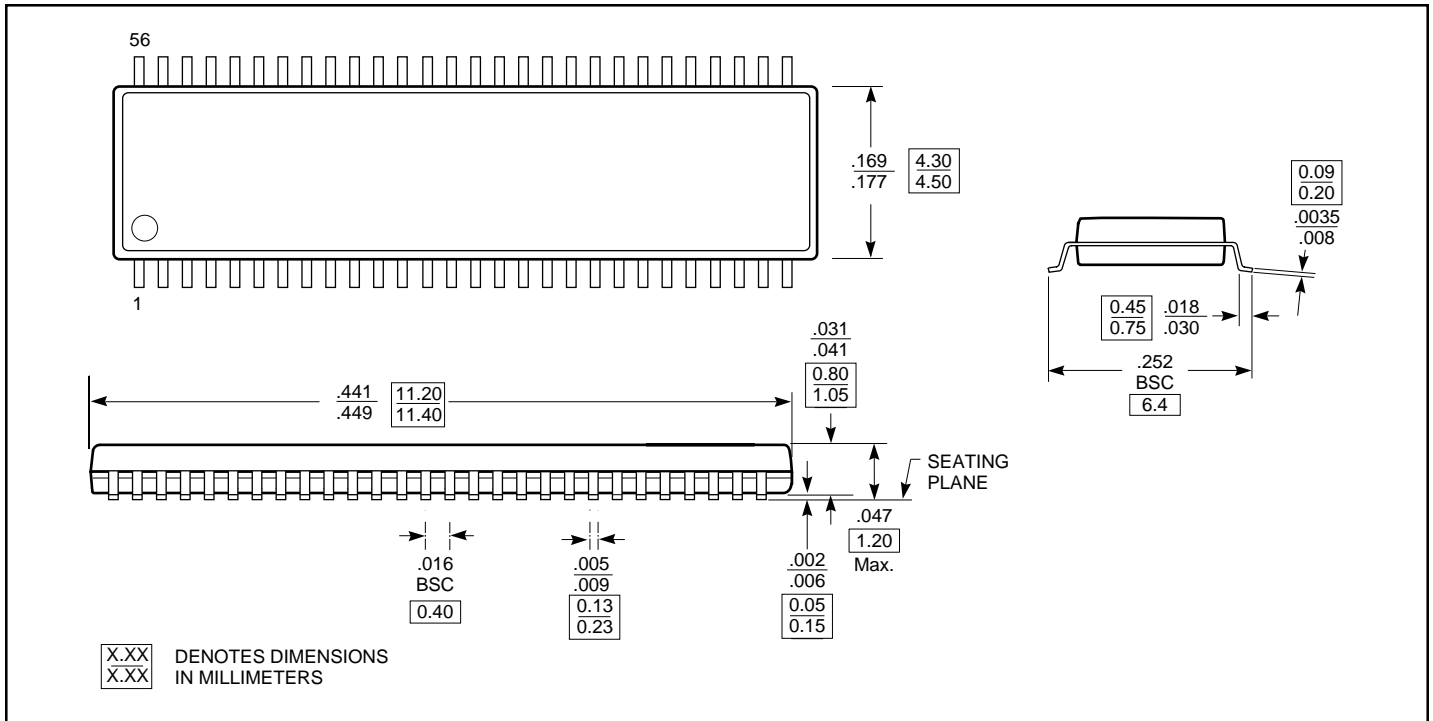

56-Pin 240-Mil Wide Thin Plastic TSSOP (A) Package

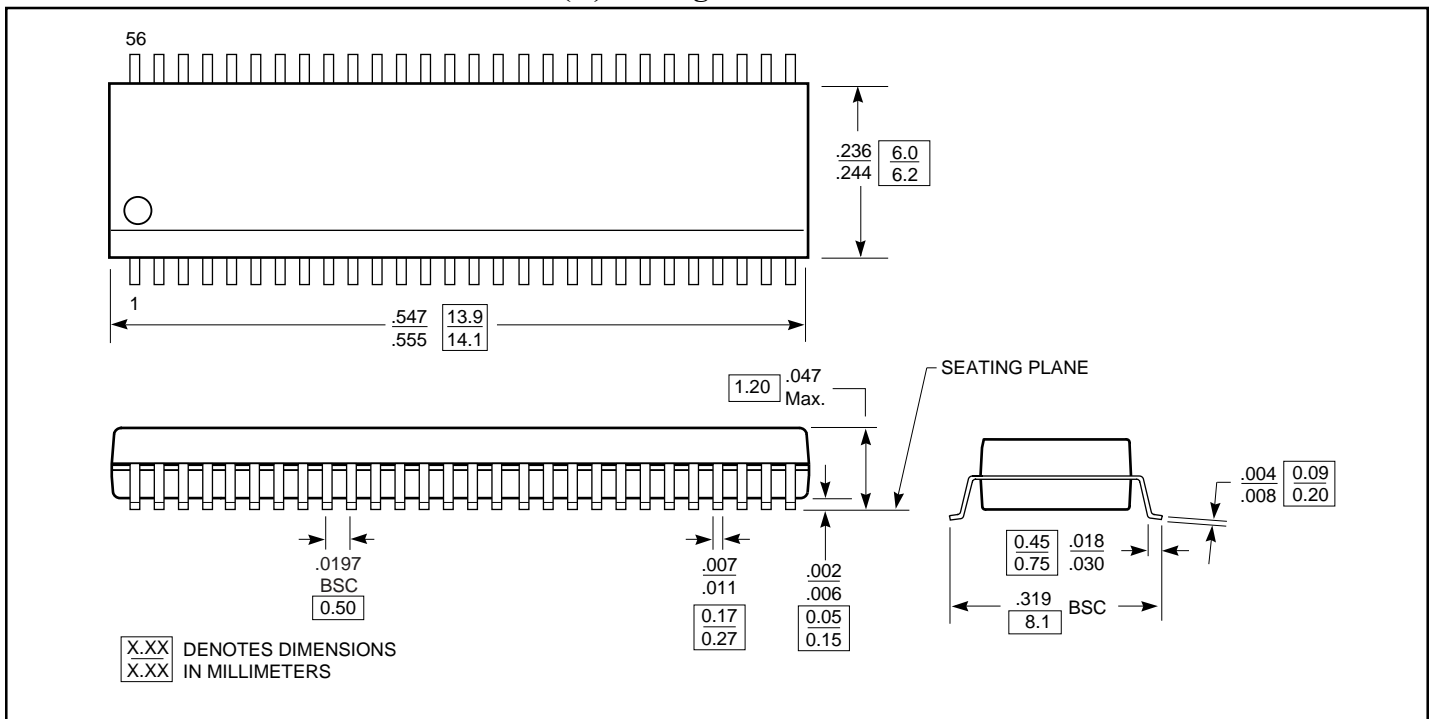

56-Pin 300-Mil Wide Thin Plastic SSOP (V) Package

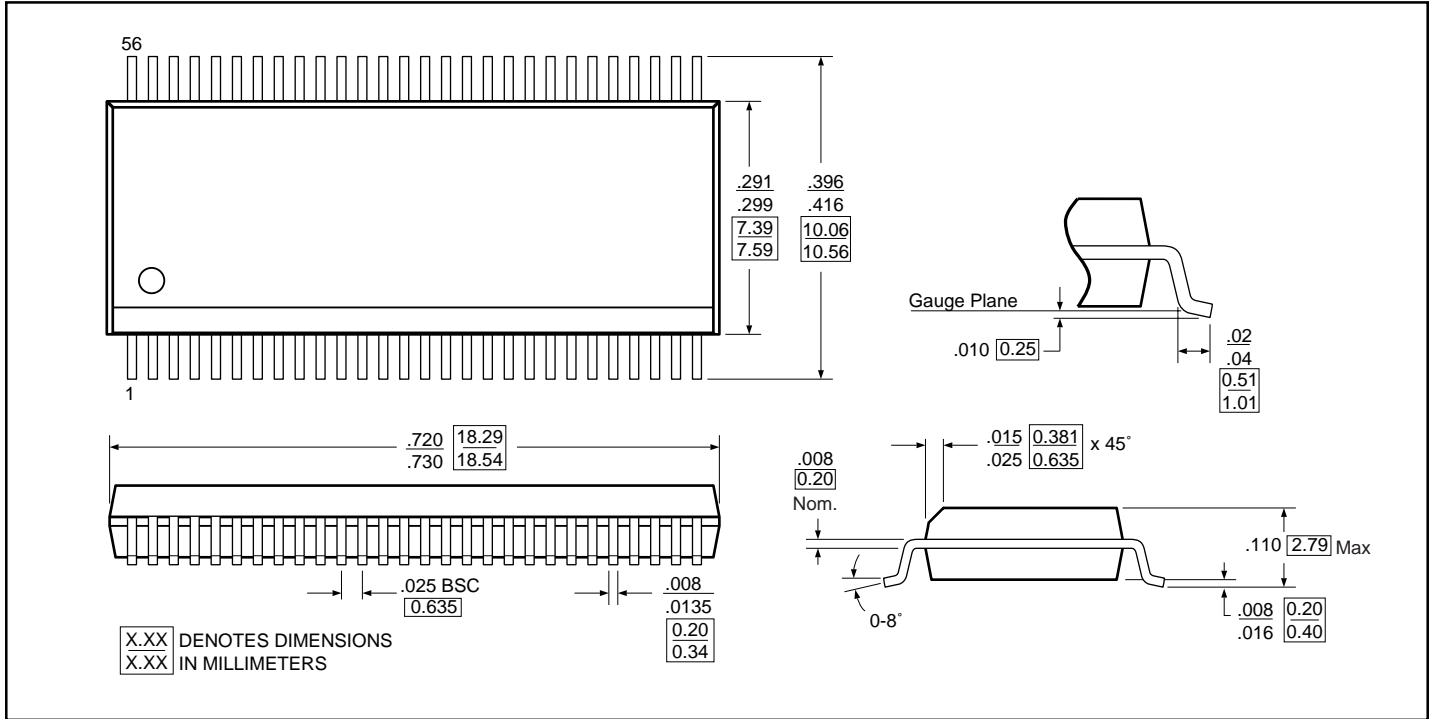

Ordering Information

Ordering Code	Package Code	Package Description
PI5C16212K	K	56-pin TVSOP
PI5C16212KE	K	Pb-free & Green, 56-pin TVSOP
PI5C16212A	A	56-pin TSSOP
PI5C16212AE	A	Pb-free & Green, 56-pin TSSOP
PI5C16212V	V	56-pin SSOP
PI5C16212VE	V	Pb-free & Green, 56-pin SSOP

Notes:

1. Thermal Characteristics can be found on the world wide web at: www.pericom.com/packaging/