



PI5C32160C

16-Bit to 32-Bit, DeMux PCI Hot-Plug Bus Switch with -1.5V Undershoot Protection

Features

- R_{ON} is 5Ω typical
- Pull-up on B1 and B2 ports
- Undershoot protection on A-port only: $-1.5V$
- Low Power: $70\mu A$ typical
- Industrial Operation Temperature: $-40^{\circ}C$ to $+85^{\circ}C$
- Near-Zero propagation delay
- Switching speed: $5ns$ max.
- Channel on capacitance: $15pF$ max.
- V_{CC} Operating Range: $+4.5V$ to $+5.5V$
- ESD $>2000V$. . . Human Body Model
- >100 MHz bandwidth (or clock rate) at $20pF$ load capacitance
- Packaging (Pb-free & Green available)
- 56-pin TSSOP (A)

Description

Pericom Semiconductor's PI5C32160C is a 16 to 32-bit demultiplexer bus switch. Industry leading advantages include a propagation delay of $250ps$, resulting from 5Ω channel resistance, and low I/O capacitance. A port demultiplexes to either 1B and 2B or to both. The switch is bidirectional.

Application

Provides PCI Hot-Plugging

Block Diagram

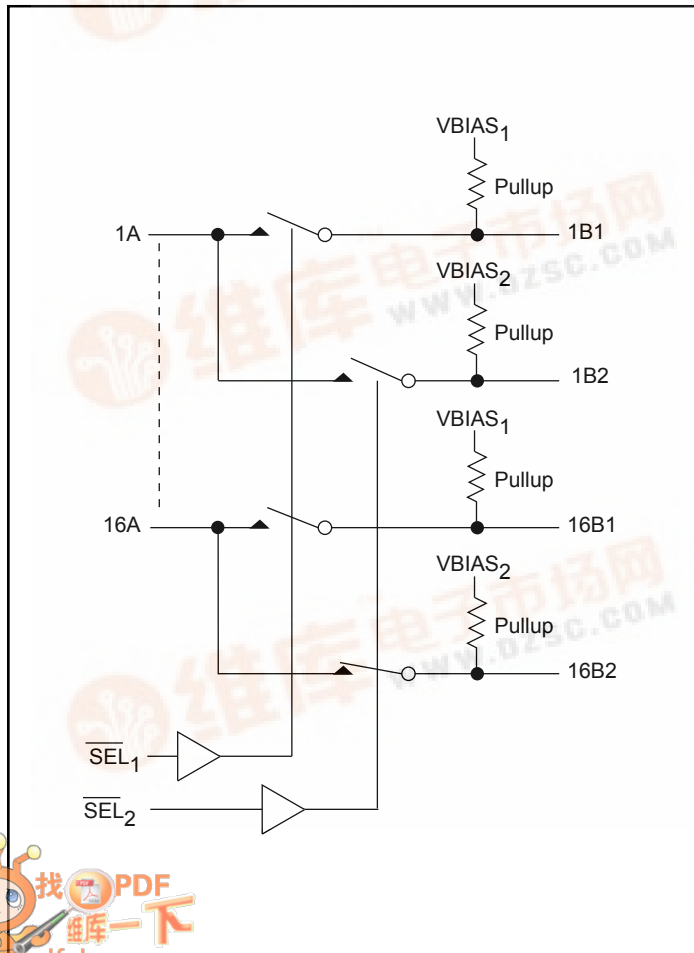

Pin Description

1B1	1	56	1A
2B1	2	55	1B2
2A	3	54	2B2
3B1	4	53	3A
4B1	5	52	3BA
4A	6	51	4BA
5B1	7	50	5A
6B1	8	49	5B2
6A	9	48	6B2
7B1	10	47	7A
8B1	11	46	7B2
8A	12	45	8B2
GND	13	44	GND
VCC	14	43	VCC
9B1	15	42	9A
10B1	16	41	9B2
10A	17	40	10B2
11B1	18	39	11A
12B1	19	38	11B2
12A	20	37	12B2
13B1	21	36	13A
14B1	22	35	13B2
14A	23	34	14B2
15B1	24	33	15A
16B1	25	32	15B2
16A	26	31	16B2
VBIAS1	27	30	VBIAS2
SEL1	28	29	SEL2





Maximum Ratings

(Above which the useful life may be impaired. For user guidelines, not tested.)

Storage Temperature	-65°C to +150°C
Ambient Temperature with Power Applied	-40°C to +85°C
Supply Voltage to Ground Potential (Inputs & V _{CC} Only).....	-0.5V to +7.0V
Supply Voltage to Ground Potential (Outputs & D/O Only) ..	-0.5V to +7.0V
DC Input Voltage	-0.5V to +7.0V
DC Output Current.....	120mA
Power Dissipation	0.5W

Note:

Stresses greater than those listed under MAXIMUM RATINGS may cause permanent damage to the device. This is a stress rating only and functional operation of the device at these or any other conditions above those indicated in the operational sections of this specification is not implied. Exposure to absolute maximum rating conditions for extended periods may affect reliability.

DC Electrical Characteristics (Over the Operating Range, T_A = -40°C to +85°C, V_{CC} = 5V ±10%, V_{BIAS} = 1.3V to V_{CC})

Parameters	Description	Test Conditions ⁽¹⁾	Min.	Typ ⁽²⁾	Max.	Units
V _{IH}	Input HIGH Voltage	Guaranteed Logic HIGH Level	2.0			V
V _{IL}	Input LOW Voltage	Guaranteed Logic LOW Level	-0.5		0.8	
I _{IH}	Input HIGH Current	V _{CC} = Max., V _{IN} = V _{CC}			±1	μA
I _{IL}	Input LOW Current	V _{CC} = Max., V _{IN} = GND			±1	
I _{IOZH}	High Impedance Output Current	A = 0V or V _{CC} Max., V _{BIAS1} = V _{BIAS2} = V _{CC} Max.			±1	
I _{IOZL}	Low Impedance Output Current	B = 0V, V _{BIAS1} = V _{BIAS2} = V _{CC} Max.	0.25		5	mA
		B = V _{CC} max., V _{BIAS1} = V _{BIAS2} = V _{CC} Max.	-1.0			μA
V _{IK}	Clamp Diode Voltage	V _{CC} = Min., I _{IN} = -18mA		-0.7	-1.8	V
R _{ON}	Switch On-Resistance ⁽⁴⁾	V _{CC} = Min., V _{IN} = 0.0V, I _{ON} = 48mA		5	8	Ω
		V _{CC} = Min., V _{IN} = 2.4V, I _{ON} = 15mA		10	15	

Truth Table

Function	$\overline{\text{SEL}}_1$	$\overline{\text{SEL}}_2$
_N A to _N B ₁	L	H
_N A to _N B ₂	H	L
_N A to _N B ₁ and _N B ₂	L	L
_N B ₁ , _N B ₂ to V _{BIAS}	H	H

Capacitance ($T_A = 25^\circ\text{C}$, $f = 1\text{ MHz}$)

Parameters ⁽⁵⁾	Description	Test Conditions	Typ.	Max.	Units
C_{IN}	Input Capacitance	$V_{IN} = 0V$	3.5		pF
C_{OFF}	A/B Capacitance, Switch Off		6.5		
C_{ON}	A/B Capacitance, Switch On		13.5		

Notes:

- For Max. or Min. conditions, use appropriate value specified under Electrical Characteristics for the applicable device type.
- Typical values are at $V_{CC} = 5.0V$, $T_A = 25^\circ\text{C}$ ambient and maximum loading.
- Not more than one output should be shorted at one time. Duration of the test should not exceed one second.
- Measured by the voltage drop between A and B pins at indicated current through the switch. On-Resistance is determined by the lower of the voltages on the two (A & B) pins.
- This parameter is determined by device characterization but is not production tested.

Power Supply Characteristics

Parameters	Description	Test Conditions ⁽¹⁾		Min.	Typ ⁽²⁾	Max.	Units
I_{CC}	Quiescent Power Supply Current	$V_{CC} = \text{Max.}$	$V_{IN} = \text{GND or } V_{CC}$		70	200	μA
ΔI_{CC}	Supply Current per Input @ TTL HIGH	$V_{CC} = \text{Max.}$	$V_{IN} = 3.4V^{(3)}$ other pin= V_{CC} or GND			2.5	mA
I_{CCD}	Supply Current per Input per MHz ⁽⁴⁾	$V_{CC} = \text{Max.}$, A and B Pins Open Control Input Toggling 50% Duty Cycle				0.25	mA/ MHz

Notes:

- For Max. or Min. conditions, use appropriate value specified under Electrical Characteristics for the applicable device.
- Typical values are at $V_{CC} = 5.0V$, $+25^\circ\text{C}$ ambient.
- Per TTL driven input ($V_{IN} = 3.4V$, control inputs only); A and B pins do not contribute to I_{CC} .
- This current applies to the control inputs only and represent the current required to switch internal capacitance at the specified frequency. The A and B inputs generate no significant AC or DC currents as they transition. This parameter is not tested, but is guaranteed by design.
- Values for these conditions are examples of the I_{CC} formula. These limits are guaranteed but not tested.

Switching Characteristics over Operating Range

Parameters	Description	Test Conditions ⁽¹⁾	PI5C32160C			Units
			Com.			
			Min.	Typ.	Max.	
t_{PLH} t_{PHL}	Propagation Delay ^(2,3) A to B	$C_L = 50\text{pF}$ $R_L = 500\Omega$		0.25		ns
t_{PZH} t_{PZL}	Bus Enable Time SEL to A,B		1.3		5.0	
t_{PHZ} t_{PLZ}	Bus Disable Time SEL to A,B		0.5		5.0	

Notes:

- See test circuit and waveforms.
- This parameter is guaranteed but not tested on Propagation Delays.
- The bus switch contributes no propagational delay other than the RC delay of the On-Resistance of the switch and the load capacitance. The time constant for the switch alone is of the order of 0.25ns for 50pF load. Since this time constant is much smaller than the rise/fall times of typical driving signals, it adds very little propagational delay to the system. Propagational delay of the bus switch when used in a system is determined by the driving circuit on the driving side of the switch and its interaction with the load on the driven side.

Applications Information

Logic Inputs

The logic control inputs can be driven up to +5.5V regardless of the supply voltage. For example, given a +5.0V supply, IN may be driven low to 0V and high to 5.5V. Driving IN Rail-to-Rail® minimizes power consumption. Proper power-supply sequencing is recommended for all CMOS devices. Always apply V_{CC} before applying V_{bias} and signals to the input/output pins.

Rail-to-Rail is a registered trademark of Nippon Motorola, Ltd

Packaging Mechanical: 56-pin TSSOP (A)

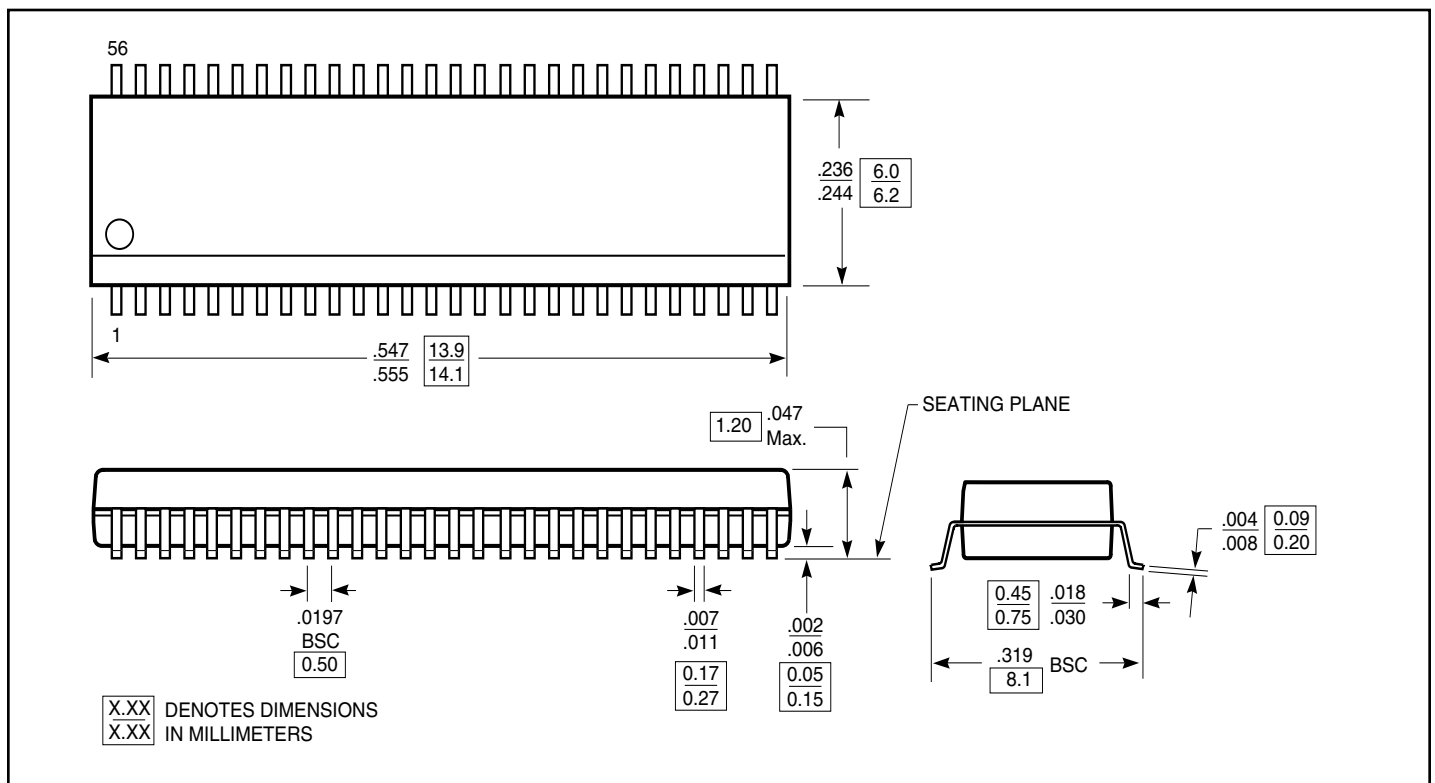

Ordering Information

Ordering Code	Package Code	Package Description
PI5C32160CA	A	56-pin 240-mil wide, TSSOP
PI5C32160CAE	A	Pb-free & Green, 56-pin 240-mil wide, TSSOP

Notes:

- Thermal characteristics can be found on the company web site at www.pericom.com/packaging/