



PI5C32161C

16-Bit to 32-Bit, Demux PCI Hot-Plug Bus Switch with -2V Undershoot Protection

Product Features

- R_{ON} is 5 Ohm typical
- Precharge on B1 and B2 ports minimizes line insertion noise
- Undershoot protection on A port only: -2V
- Low Power: 70 μ A typical
- Industrial Operation Temperature: -40°C to +85°C
- Near Zero propagation delay
- Channel ON Capacitance: 15pF max.
- V_{CC} Operating Range: +3.0V to +3.6V
- ESD>2000V....Human Body Model
- >100 MHz switching (enable clock rate) at 20pF load capacitance
- Packages available:
 - 56-pin plastic TSSOP (A)

Product Description

Pericom Semiconductor's PI5C series of logic circuits are produced using the Company's advanced submicron CMOS technology, achieving industry leading performance.

The PI5C32161C is a 16- to 32-bit demultiplexer bus switch. It is intended for PCI Hot-Plug applications. Industry leading advantages include a propagation delay of 250ps, resulting from 5-Ohm channel resistance, and low I/O Capacitance. A port demultiplexes to either 1B and 2B or to both. The switch is bidirectional. Precharge bias voltage is provided on B ports to minimize live insertion noise. The A port can handle up to -2V undershoot during switch disable.

Application

Provides PCI Hot Plugging

Logic Block Diagram

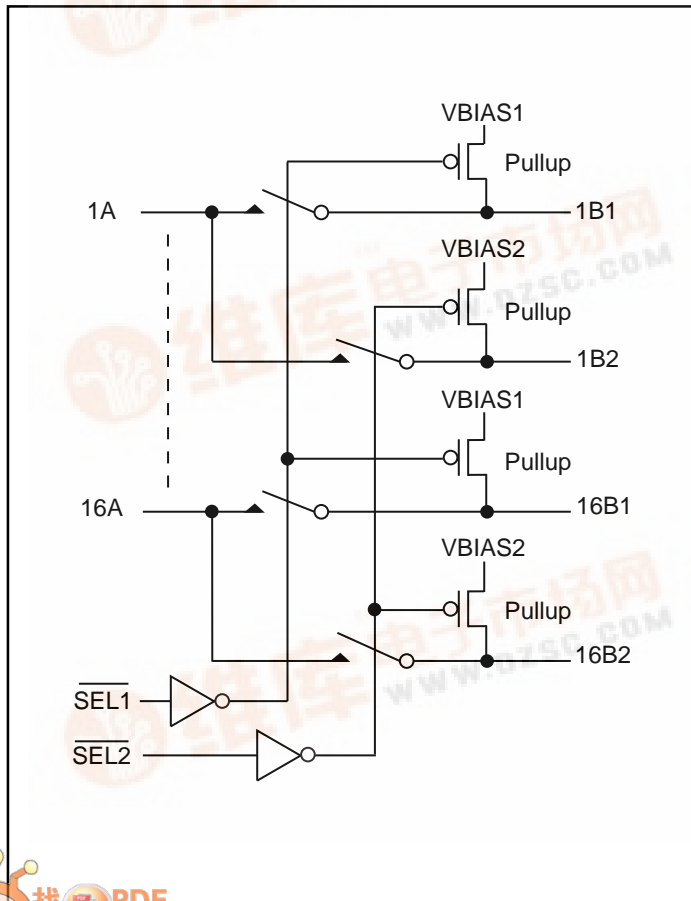

Pin Description

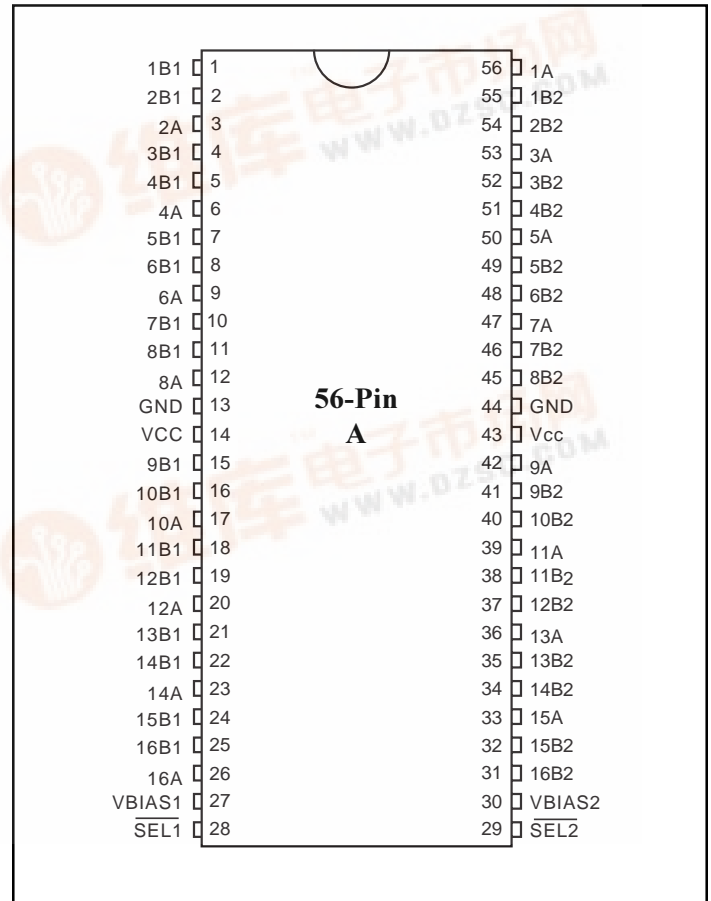



PI5C32161C
16-Bit to 32-Bit, Demux PCI Hot-Plug
Bus Switch with -2V Undershoot Protection

Function	$\overline{\text{SEL1}}$	$\overline{\text{SEL2}}$
nA to nB1	L	H
nA to nB2	H	L
nA to nB1 and nB2	L	L
nB1, nB2 = V_{BIAS}	H	H

Maximum Ratings

(Above which the useful life may be impaired. For user guidelines, not tested.)

Storage Temperature	-65°C to +150°C
Ambient Temperature with Power Applied	-40°C to +85°C
Supply Voltage to Ground Potential (Inputs & V_{CC} Only)	-0.5V to +7.0V
Supply Voltage to Ground Potential (Outputs & D/O Only)	-0.5V to +7.0V
DC Input Voltage	-0.5V to +7.0V
DC Output Current	120mA
Power Dissipation	0.5W

Note:

Stresses greater than those listed under MAXIMUM RATINGS may cause permanent damage to the device. This is a stress rating only and functional operation of the device at these or any other conditions above those indicated in the operational sections of this specification is not implied. Exposure to absolute maximum rating conditions for extended periods may affect reliability.

DC Electrical Characteristics (Over the Operating Range, $T_A = -40^\circ\text{C}$ to $+85^\circ\text{C}$, $V_{\text{CC}} = 5\text{V} \pm 10\%$, $V_{\text{BIAS}} = 1.3\text{V}$ to V_{CC})

Parameters	Description	Test Conditions ⁽¹⁾	Min.	Typ ⁽²⁾	Max.	Units
V_{IH}	Input HIGH Voltage	Guaranteed Logic HIGH Level	2.0	—	—	V
V_{IL}	Input LOW Voltage	Guaranteed Logic LOW Level	-0.5	—	0.8	V
I_{IH}	Input HIGH Current	$V_{\text{CC}} = \text{Max.}, V_{\text{IN}} = V_{\text{CC}}$	—	—	± 1	μA
I_{IL}	Input LOW Current	$V_{\text{CC}} = \text{Max.}, V_{\text{IN}} = \text{GND}$	—	—	± 1	μA
I_{OZA}	High Impedance Output Current	A=0V or V_{CC} max., $V_{\text{BIAS1}} = V_{\text{BIAS2}} = V_{\text{CC}}$ max.	—	—	± 1	μA
I_{OZB}	High Impedance Output Current	B=0V or V_{CC} max., $V_{\text{BIAS1}} = V_{\text{BIAS2}} = V_{\text{CC}}$ max.	-0.2	—	-2	mA
V_{IK}	Clamp Diode Voltage	$V_{\text{CC}} = \text{Min.}, I_{\text{IN}} = -18\text{mA}$	—	-0.7	-1.8	V
r_{ON}	Switch On Resistance ⁽⁴⁾	$V_{\text{CC}} = \text{Min.}, V_{\text{IN}} = 0.0\text{V}, I_{\text{ON}} = 48\text{mA}$	—	5	8	Ω
		$V_{\text{CC}} = \text{Min.}, V_{\text{IN}} = 2.4\text{V}, I_{\text{ON}} = 15\text{mA}$	—	10	15	Ω



Capacitance ($T_A = 25^\circ\text{C}$, $f = 1\text{ MHz}$)

Parameters ⁽⁵⁾	Description	Test Conditions	Typ.	Max.	Units
C_{IN}	Input Capacitance	$V_{IN} = 0\text{V}$	3.5	—	pF
C_{OFF}	A/B Capacitance, Switch Off	$V_{IN} = 0\text{V}$	4.5	—	pF
C_{ON}	A/B Capacitance, Switch On	$V_{IN} = 0\text{V}$	13.5	—	pF

Notes:

1. For Max. or Min. conditions, use appropriate value specified under Electrical Characteristics for the applicable device type.
2. Typical values are at $V_{CC} = 5.0\text{V}$, $T_A = 25^\circ\text{C}$ ambient and maximum loading.
3. Not more than one output should be shorted at one time. Duration of the test should not exceed one second.
4. Measured by the voltage drop between A and B pins at indicated current through the switch. ON resistance is determined by the lower of the voltages on the two (A & B) pins.
5. This parameter is determined by device characterization but is not production tested.

Power Supply Characteristics

Parameters	Description	Test Conditions ⁽¹⁾		Min.	Typ ⁽²⁾	Max.	Units
I_{CC}	Quiescent Power Supply Current	$V_{CC} = \text{Max.}$	$V_{IN} = \text{GND or } V_{CC}$	—	—	200	μA
ΔI_{CC}	Supply Current per Input @ TTL HIGH	$V_{CC} = \text{Max.}$	$V_{IN} = 3.4\text{V}^{(3)}$ other pin= V_{CC} or GND	—	—	2.5	mA
I_{CCD}	Supply Current per Input per MHz ⁽⁴⁾	$V_{CC} = \text{Max.}$, A and B Pins Open Control Input Toggling 50% Duty Cycle		—	—	0.25	mA/ MHz

Notes:

1. For Max. or Min. conditions, use appropriate value specified under Electrical Characteristics for the applicable device.
2. Typical values are at $V_{CC} = 5.0\text{V}$, $+25^\circ\text{C}$ ambient.
3. Per TTL driven input ($V_{IN} = 3.4\text{V}$, control inputs only); A and B pins do not contribute to I_{CC} .
4. This current applies to the control inputs only and represent the current required to switch internal capacitance at the specified frequency. The A and B inputs generate no significant AC or DC currents as they transition. This parameter is not tested, but is guaranteed by design.
5. Values for these conditions are examples of the I_{CC} formula. These limits are guaranteed but not tested.

Switching Characteristics over Operating Range

Parameters	Description	Conditions ⁽¹⁾	PI5C32161C			Units
			Com.			
			Min.	Typ.	Max.	
t_{PLH} t_{PHL}	Propagation Delay ^(2,3) A to B	$C_L = 50\text{pF}$ $R_L = 500\Omega$	—	0.25	—	ns
t_{PZH} t_{PZL}	Bus Enable Time SEL TO A,B		10	—	35	
t_{PHZ} t_{PLZ}	Bus Disable Time SEL to A,B		1	—	6	

Notes:

1. See test circuit and waveforms.
2. This parameter is guaranteed but not tested on Propagation Delays.
3. The bus switch contributes no propagational delay other than the RC delay of the ON resistance of the switch and the load capacitance. The time constant for the switch alone is of the order of 0.25ns for 50pF load. Since this time constant is much smaller than the rise/fall times of typical driving signals, it adds very little propagational delay to the system. Propagational delay of the bus switch when used in a system is determined by the driving circuit on the driving side of the switch and its interaction with the load on the driven side.



56-pin TSSOP (A)

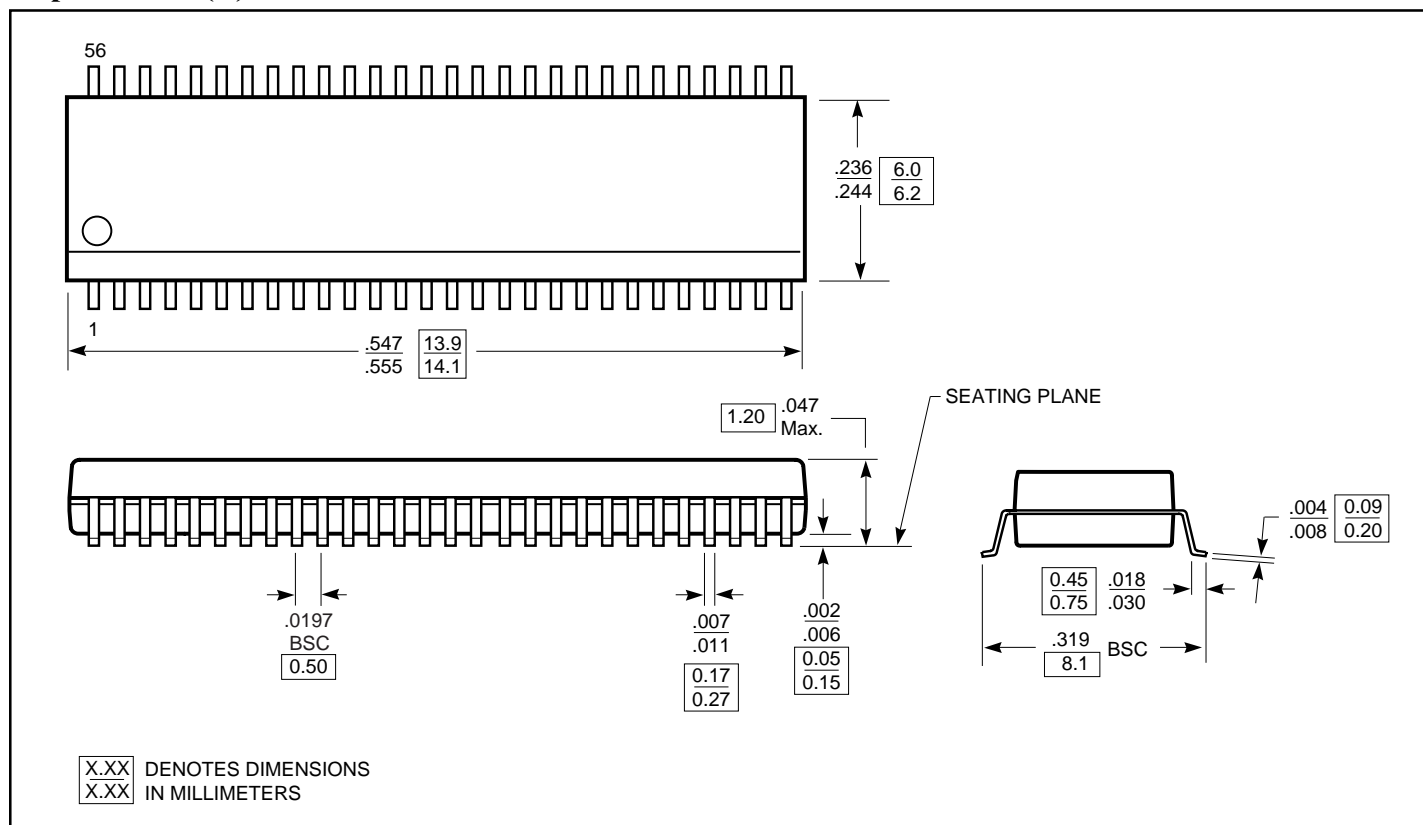

Ordering Information

Part	Pin - Package	Width
PI5C32161CA	56-TSSOP (A)	240-mil

Applications Information

Logic Inputs

The logic control inputs can be driven up to +5.5V regardless of the supply voltage. For example, given a +5.0V supply, IN may be driven low to 0V and high to 5.5V. Driving IN Rail-to-Rail® minimizes power consumption.

Power-Supply Sequencing

Proper power-supply sequencing is recommended for all CMOS devices. Always apply V_{CC} before applying signals to the bias voltage pin and the input/output or control pins.

Rail-to-Rail is a registered trademark of Nippon Motorola, Ltd