



# PI5C32X245

## 16-Bit, 2-Port BusSwitch

### Product Features:

- Near-Zero propagation delay
- 5Ω switches connect inputs to outputs
- Direct bus connection when switches are ON
- Ultra-low quiescent power (0.2μA typical)
  - Ideally suited for notebook applications
- Pin compatible with QS32X245
- Industrial operating temperature: -40°C to +85°C
- Packaging (Pb-free & Green available):
  - 40-pin 150-mil wide plastic BQSOP (B)

### Description:

Pericom Semiconductor's PI5C32X245 is a 16-bit, 2-port bus switch. Two enable signals ( $\overline{BEn}$ ) turn the switches on. The bus switch creates no additional propagational delay or additional ground bounce noise.

### Block Diagram

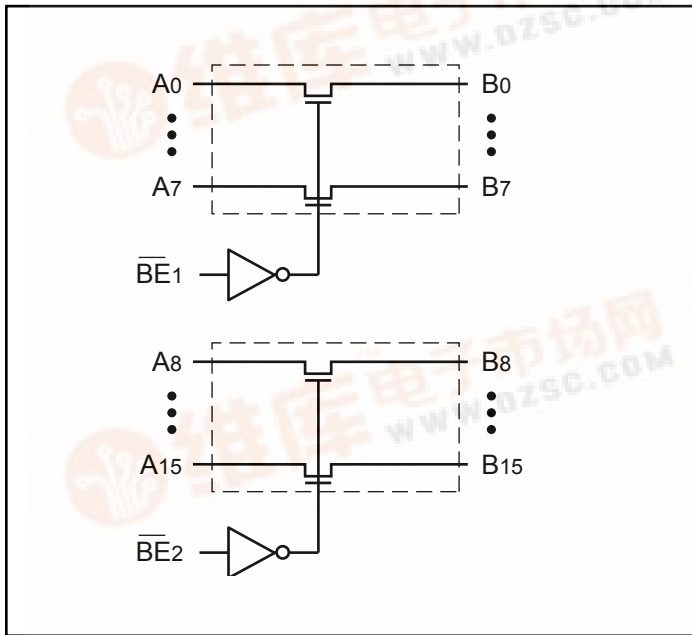

### Pin Configuration

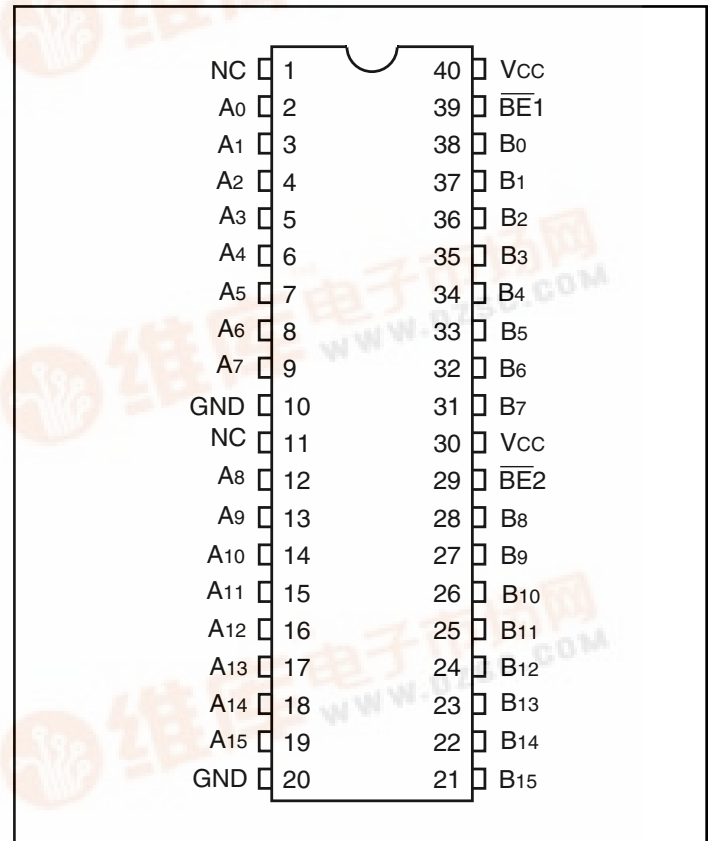

### Truth Table<sup>(1)</sup>

Function	$\overline{BEn}$	A0-15
Disconnect	H	Hi-Z
Connect	L	B0-15

#### Note:

1. H = High Voltage Level, L = Low Voltage Level, Hi-Z = High Impedance

### Pin Description

Pin Name	I/O	Description
$\overline{BEn}$	I	Bus Enable Input (Active LOW)
A0-A15	I/O	Bus A
B0-B15	I/O	Bus B



### Maximum Ratings

(Above which the useful life may be impaired. For user guidelines, not tested.)

Storage Temperature .....	-65°C to +150°C
Ambient Temperature with Power Applied .....	-40°C to +85°C
Supply Voltage to Ground Potential (Inputs & V <sub>CC</sub> Only) ...	-0.5V to +7.0V
Supply Voltage to Ground Potential (Outputs & D/O Only)	-0.5V to +7.0V
DC Input Voltage .....	-0.5V to +7.0V
DC Output Current.....	120 mA
Power Dissipation .....	0.5W

**Note:**

Stresses greater than those listed under MAXIMUM RATINGS may cause permanent damage to the device. This is a stress rating only and functional operation of the device at these or any other conditions above those indicated in the operational sections of this specification is not implied. Exposure to absolute maximum rating conditions for extended periods may affect reliability.

### DC Electrical Characteristics (Over the Operating Range, T<sub>A</sub> = -40°C to +85°C, V<sub>CC</sub> = 5V ±10%)

Parameters	Description	Test Conditions <sup>(1)</sup>	Min.	Typ <sup>(2)</sup>	Max.	Units
V <sub>IH</sub>	Input HIGH Voltage	Guaranteed Logic HIGH Level	2.0	–	–	V
V <sub>IL</sub>	Input LOW Voltage	Guaranteed Logic LOW Level	-0.5	–	0.8	
I <sub>IH</sub>	Input HIGH Current	V <sub>CC</sub> = Max., V <sub>IN</sub> = V <sub>CC</sub>	–	–	±1	µA
I <sub>IL</sub>	Input LOW Current	V <sub>CC</sub> = Max., V <sub>IN</sub> = GND	–	–	±1	
I <sub>OZH</sub>	High Impedance Output Current	0 ≤ A, B ≤ V <sub>CC</sub>	–	–	±1	
V <sub>IK</sub>	Clamp Diode Voltage	V <sub>CC</sub> = Min., I <sub>IN</sub> = -18 mA	–	-0.7	-1.2	V
I <sub>OS</sub>	Short Circuit Current <sup>(3)</sup>	A (B) = 0V, B (A) = V <sub>CC</sub>	100	–	–	mA
V <sub>H</sub>	Input Hysteresis at Control Pins		–	150	–	mV
R <sub>OH</sub>	Switch On-Resistance <sup>(4)</sup>	V <sub>CC</sub> = Min., V <sub>IN</sub> = 0.0V, I <sub>ON</sub> = 48 mA	–	5	7	Ω
		V <sub>CC</sub> = Min., V <sub>IN</sub> = 2.4V, I <sub>ON</sub> = 15 mA	–	10	15	

### Capacitance (T<sub>A</sub> = 25°C, f = 1 MHz)

Parameters <sup>(5)</sup>	Description	Test Conditions	Typ	Units
C <sub>IN</sub>	Input Capacitance	V <sub>IN</sub> = 0V	6	pF
C <sub>OFF</sub>	A/B Capacitance, Switch Off		6	
C <sub>ON</sub>	A/B Capacitance, Switch On		12	

**Notes:**

- For Max. or Min. conditions, use appropriate value specified under Electrical Characteristics for the applicable device type.
- Typical values are at V<sub>CC</sub> = 5.0V, T<sub>A</sub> = 25°C ambient and maximum loading.
- Not more than one output should be shorted at one time. Duration of the test should not exceed one second.
- Measured by the voltage drop between A and B pin at indicated current through the switch. On-Resistance is determined by the lower of the voltages on the two (A,B) pins.
- This parameter is determined by device characterization but is not production tested.

**Power Supply Characteristics**

Parameters	Description	Test Conditions <sup>(1)</sup>		Min.	Typ <sup>(2)</sup>	Max.	Units
I <sub>CC</sub>	Quiescent Power Supply Current	V <sub>CC</sub> = Max.	V <sub>IN</sub> = GND or V <sub>CC</sub>		0.1	3.0	μA
ΔI <sub>CC</sub>	Supply Current per Input @ TTL HIGH	V <sub>CC</sub> = Max.	V <sub>IN</sub> = 3.4V <sup>(3)</sup>			2.5	mA
I <sub>CCD</sub>	Supply Current per Input per MHz <sup>(4)</sup>	V <sub>CC</sub> = Max., A and B Pins Open $\overline{\text{BEn}}$ = GND Control Input Toggling 50% Duty Cycle				0.25	mA/ MHz

**Notes:**

1. For Max. or Min. conditions, use appropriate value specified under Electrical Characteristics for the applicable device.
2. Typical values are at V<sub>CC</sub> = 5.0V, +25°C ambient.
3. Per TTL driven input (V<sub>IN</sub> = 3.4V, control inputs only); A and B pins do not contribute to I<sub>CC</sub>.
4. This current applies to the control inputs only and represent the current required to switch internal capacitance at the specified frequency. The A and B inputs generate no significant AC or DC currents as they transition. This parameter is not tested, but is guaranteed by design.

**Switching Characteristics over Operating Range**

Parameters	Description	Conditions <sup>(1)</sup>	Com.		Unit
			Min.	Max.	
t <sub>PLH</sub> t <sub>PHL</sub>	Propagation Delay <sup>(2,3)</sup> Ax to Bx, Bx to Ax	C <sub>L</sub> = 50pF R <sub>L</sub> = 500Ω	—	0.25	ns
t <sub>PZH</sub> t <sub>PZL</sub>	Bus Enable Time $\overline{\text{BEx}}$ to Ax or Bx		1.5	6.5	
t <sub>PHZ</sub> t <sub>PLZ</sub>	Bus Disable Time $\overline{\text{BEx}}$ to Ax or Bx		1.5	5.5	

**Notes:**

1. See test circuit and waveforms.
2. This parameter is guaranteed but not tested on Propagation Delays.
3. The bus switch contributes no propagational delay other than the RC delay of the On-Resistance of the switch and the load capacitance. The time constant for the switch alone is of the order of 0.25ns for 50pF load. Since this time constant is much smaller than the rise/fall times of typical driving signals, it adds very little propagational delay to the system. Propagational delay of the bus switch when used in a system is determined by the driving circuit on the driving side of the switch and its interaction with the load on the driven side.

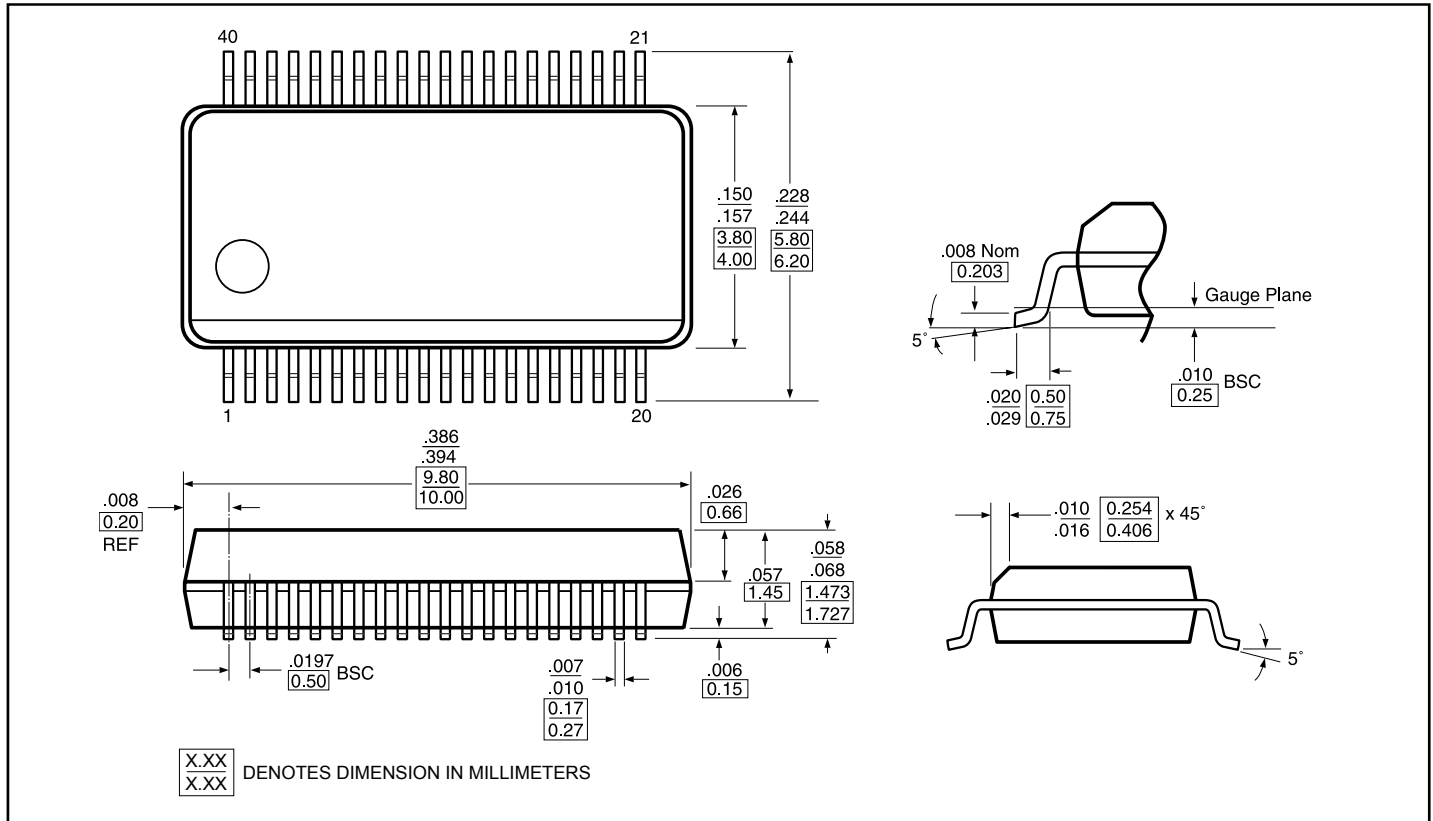
**Packaging Mechanical: 40-pin BQSOP (B)**

**Ordering Information**

Ordering Code	Package Code	Package Description
PI5C32X245B	B	40-pin BQSOP
PI5C32X245BE	B	Pb-free & Green, 40-pin BQSOP

**Notes:**

- Thermal characteristics can be found on the company web site at [www.pericom.com/packaging/](http://www.pericom.com/packaging/)