



## PI5C3306

### 2-Bit Bus Switch with Active Low Enables

#### Product Features

- Near zero propagation delay
- 5-Ohm switches connect inputs to outputs
- Direct bus connection when switches are ON
- Ultra Low Quiescent Power (0.2μA Typical)
  - Ideally suited for notebook applications
- Packages available:
  - 8-pin 173 mil wide plastic TSSOP (L)
  - 8-pin 118 mil wide plastic MSOP (U)

#### Product Description

Pericom Semiconductor's PI5C series of logic circuits are produced using the Company's advanced submicron CMOS technology, achieving industry leading speed grades.

The PI5C3306 is a 2-bit bus switch designed with two 5-ohm bus switches with fast individual enables. When enabled via the associated Bus Enable ( $\overline{BE}$ ) pin, the "A" pin is directly connected to the "B" pin for that particular gate. The bus switch introduces no additional propagation delay or additional ground bounce noise.

The PI5C3306 device has active LOW enables.

#### Logic Block Diagram

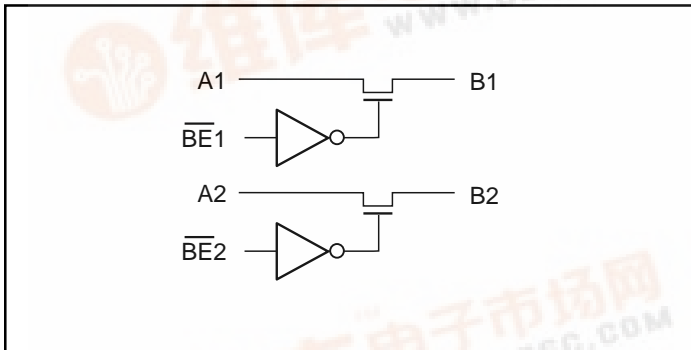

#### Product Pin Configuration

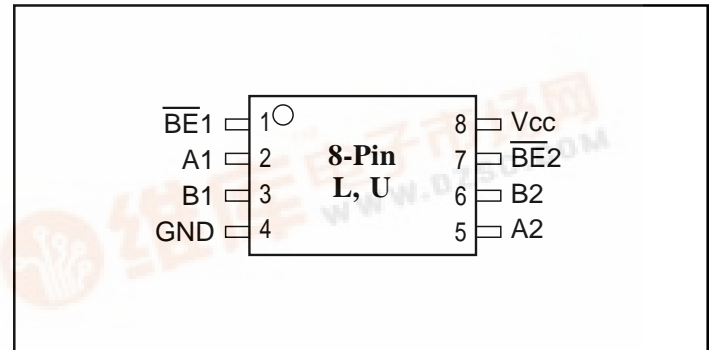

#### Product Pin Description

Pin Name	Description
$\overline{BE}_n$	Switch Enable
A2-A1	Bus A
B2-B1	Bus B
Vcc	Power
GND	Ground

#### Truth Table<sup>(1)</sup>

$\overline{BE}_n$	A <sub>n</sub>	B <sub>n</sub>	Vcc	Function
X*	Hi-Z	Hi-Z	GND	Disconnect
H	Hi-Z	Hi-Z	Vcc	Disconnect
L	B <sub>n</sub>	A <sub>n</sub>	Vcc	Connect

#### Notes:

1. H = High Voltage Level, L = Low Voltage Level  
Hi-Z = High Impedance, X = Don't Care

\* A pull-up resistor should be provided for power-up protection.



**Maximum Ratings**

(Above which the useful life may be impaired. For user guidelines, not tested.)

Storage Temperature .....	-65°C to +150°C
Ambient Temperature with Power Applied .....	-40°C to +85°C
Supply Voltage to Ground Potential (Inputs & V <sub>CC</sub> Only) .....	-0.5V to +7.0V
Supply Voltage to Ground Potential (Outputs & D/O Only) .....	-0.5V to +7.0V
DC Input Voltage .....	-0.5V to +7.0V
DC Output Current .....	120mA
Power Dissipation .....	0.5W

**Note:**

Stresses greater than those listed under MAXIMUM RATINGS may cause permanent damage to the device. This is a stress rating only and functional operation of the device at these or any other conditions above those indicated in the operational sections of this specification is not implied. Exposure to absolute maximum rating conditions for extended periods may affect reliability.

**DC Electrical Characteristics** (Over the Operating Range, T<sub>A</sub> = -40°C to +85°C, V<sub>CC</sub> = 4V to 5.5V)

Parameters	Description	Test Conditions <sup>(1)</sup>	Min.	Typ <sup>(2)</sup>	Max.	Units
V <sub>IH</sub>	Input HIGH Voltage	Guaranteed Logic HIGH Level	2.0			V
V <sub>IL</sub>	Input LOW Voltage	Guaranteed Logic LOW Level	-0.5		0.8	V
I <sub>IH</sub>	Input HIGH Current	V <sub>CC</sub> = Max., V <sub>IN</sub> = V <sub>CC</sub>			±1	µA
I <sub>IL</sub>	Input LOW Current	V <sub>CC</sub> = Max., V <sub>IN</sub> = GND			±1	µA
I <sub>OZH</sub>	High Impedance Output Current	0 ≤ A, B ≤ V <sub>CC</sub>			±1	µA
I <sub>OZL</sub>	Low Impedance Output Current	0 ≤ A, B ≤ V <sub>CC</sub>			±1	mA
V <sub>H</sub>	Input Hysteresis at Control Pins			300		mV
R <sub>ON</sub>	Switch On Resistance <sup>(3)</sup>	V <sub>CC</sub> = 4.5V, V <sub>IN</sub> = 0.0V, I <sub>ON</sub> = 30mA or 64mA V <sub>CC</sub> = 4.5V, V <sub>IN</sub> = 2.4V, I <sub>ON</sub> = 15mA		5 10	7 15	Ω

**Capacitance** (T<sub>A</sub> = 25°C, f = 1 MHz)

Parameters <sup>(4)</sup>	Description	Test Conditions	Typ	Units
C <sub>IN</sub>	Input Capacitance	V <sub>IN</sub> = 0V	3	pF
C <sub>OFF</sub>	A/B Capacitance, Switch Off	V <sub>IN</sub> = 0V	5	pF
C <sub>ON</sub>	A/B Capacitance, Switch On	V <sub>IN</sub> = 0V	10	pF

**Notes:**

1. For Max. or Min. conditions, use appropriate value specified under Electrical Characteristics for the applicable device type.
2. Typical values are at V<sub>CC</sub> = 5.0V, T<sub>A</sub> = 25°C ambient and maximum loading.
3. Measured by the voltage drop between A and B pin at indicated current through the switch. ON resistance is determined by the lower of the voltages on the two (A, B) pins.
4. This parameter is determined by device characterization but is not production tested.

**Power Supply Characteristics**

Parameters	Description	Test Conditions <sup>(1)</sup>		Min.	Typ <sup>(2)</sup>	Max.	Units
I <sub>CC</sub>	Quiescent Power Supply Current	V <sub>CC</sub> = Max.	V <sub>IN</sub> = GND or V <sub>CC</sub>		0.1	3.0	µA
ΔI <sub>CC</sub>	Supply Current per Input @ TTL HIGH	V <sub>CC</sub> = Max.	V <sub>IN</sub> = 3.4V <sup>(3)</sup>			2.5	mA

**Notes:**

1. For Max. or Min. conditions, use appropriate value specified under Electrical Characteristics for the applicable device.
2. Typical values are at V<sub>CC</sub> = 5.0V, +25°C ambient.
3. Per TTL driven input (V<sub>IN</sub> = 3.4V, control inputs only); A and B pins do not contribute to I<sub>CC</sub>.



### PI5C3306 Switching Characteristics over Operating Range

Parameters	Description	Conditions <sup>(1)</sup>	PI3C3306				Units
			V <sub>CC</sub> = 5V ±10%		V <sub>CC</sub> = 4V		
			Min.	Max.	Min.	Max.	
t <sub>PLH</sub> t <sub>PHL</sub>	Propagation Delay <sup>(2,3)</sup> A to B, B to A	C <sub>L</sub> = 50pF R <sub>L</sub> = 500Ω	—	0.25		0.25	ns
t <sub>PZH</sub> t <sub>PZL</sub>	Bus Enable Time		1.0	4.9		5.5	
t <sub>PHZ</sub> t <sub>PLZ</sub>	Bus Disable Time		1.0	4.2		4.5	

**Notes:**

1. See test circuit and waveforms.
2. This parameter is guaranteed but not tested on Propagation Delays.
3. The bus switch contributes no propagational delay other than the RC delay of the ON resistance of the switch and the load capacitance. The time constant for the switch alone is of the order of 0.25ns for 50pF load. Since this time constant is much smaller than the rise/fall times of typical driving signals, it adds very little propagational delay to the system. Propagational delay of the bus switch when used in a system is determined by the driving circuit on the driving side of the switch and its interaction with the load on the driven side.

### Ordering Information

Part	Pin - Package	Temperature
PI5C3306L	8 - TSSOP (L)	-40°C to +85°C
PI5C3306UX	8 - MSOP (U)	