



PI74ALVCH162820

3.3V 10-Bit Flip-Flop with Dual Outputs and 3-State Outputs

Product Features

- PI74ALVCH162820 is designed for low voltage operation
- $V_{CC}=2.3V$ to $3.6V$
- Hysteresis on all inputs
- Typical VOLP (Output Ground Bounce) $<0.8V$ at $V_{CC}=3.3V, T_A=25^\circ C$
- Typical VOHV (Output VOH Undershoot) $<2.0V$ at $V_{CC}=3.3V, T_A=25^\circ C$
- Output ports have equivalent 26Ω series resistors, no external resistors are required.
- Bus Hold retains last active bus state during 3-state eliminates the need for external pullup resistors
- Industrial operation at $-40^\circ C$ to $+85^\circ C$
- Packages available:
 - 56-pin 240 mil wide plastic TSSOP (A)
 - 56-pin 300 mil wide plastic SSOP (V)

Product Description

Pericom Semiconductor's PI74ALVCH series of logic circuits are produced in the Company's advanced 0.5 micron CMOS technology, achieving industry leading speed.

The PI74ALVCH162820 is a 10-bit flip-flop designed for 2.3V to 3.3V V_{CC} operation. The PI74ALVCH162820 is designed with edge-triggered D-type flip-flops. On the positive transition of clock (CLK) input, the device provides true data at the Q outputs.

A buffered output-enable (\overline{OE}) input can be used to place the ten outputs in either a normal logic state (HIGH or LOW level) or a high-impedance state. In the high-impedance state, the outputs neither load nor drive the bus lines significantly. The high-impedance state and increased drive provide the capacity to drive bus lines without the need for interface or pullup components. \overline{OE} does not affect the internal operation of the flip-flops. Old data can be retained or new data can be entered while the outputs are in the high-impedance state.

The outputs, which are designed to sink up to 12mA, include 26Ω resistors to reduce overshoot and undershoot.

The PI74ALVCH162820 has "Bus Hold" which retains the data input's last state whenever the data input goes to high-impedance preventing "floating" inputs and eliminating the need for pullup/down resistors.

Active bus-hold circuitry is provided to hold unused or floating data inputs at a valid logic level.

Logic Block Diagram

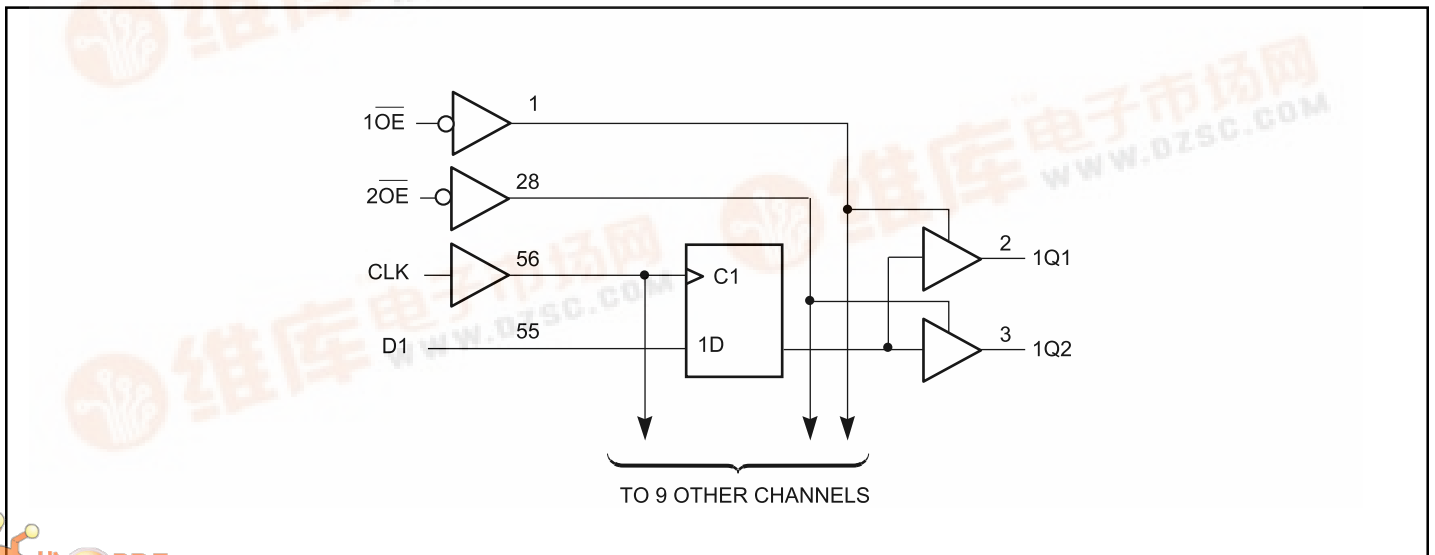



PI74ALVCH162820
3.3V 10-BIT FLIP-FLOP WITH
DUAL OUTPUTS AND 3-STATE OUTPUTS

Product Pin Description

Pin Name	Description
\overline{OE}	Output Enable Input (Active LOW)
CLK	Clock Input (Active HIGH)
D _x	Data Inputs
Q _x	3-State Outputs
GND	Ground
V _{cc}	Power

Truth Table⁽¹⁾

Inputs			Outputs
\overline{OE}_n	CLK	D	Q _n
L	↑	H	H
L	↑	L	L
L	L	X	Q ₀
H	X	X	Z

Note:

1. H = High Signal Level
- L = Low Signal Level
- X = Irrelevant
- Z = High Impedance
- ↑ = LOW-to-HIGH Transition
- n = 1,2

Product Pin Configuration

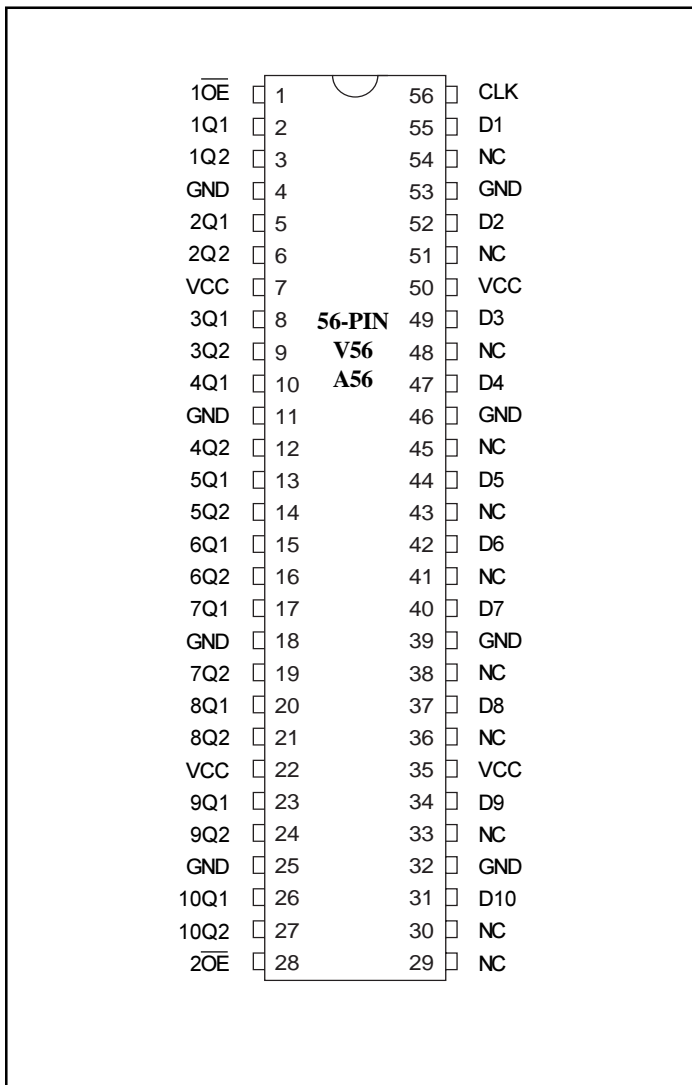



PI74ALVCH162820
3.3V 10-BIT FLIP-FLOP WITH
DUAL OUTPUTS AND 3-STATE OUTPUTS

Maximum Ratings

(Above which the useful life may be impaired. For user guidelines, not tested.)

Storage Temperature	-65°C to +150°C
Ambient Temperature with Power Applied	-40°C to +85°C
Input Voltage Range, V_{IN}	-0.5V to $V_{CC}+0.5V$
Output Voltage Range, V_{OUT}	-0.5V to $V_{CC}+0.5V$
DC Input Voltage	-0.5V to +5.0V
DC Output Current	100 mA
Power Dissipation	1.0W

Note:

Stresses greater than those listed under MAXIMUM RATINGS may cause permanent damage to the device. This is a stress rating only and functional operation of the device at these or any other conditions above those indicated in the operational sections of this specification is not implied. Exposure to absolute maximum rating conditions for extended periods may affect reliability.

DC Electrical Characteristics (Over the Operating Range, $T_A = -40^\circ\text{C}$ to $+85^\circ\text{C}$, $V_{CC} = 3.3V \pm 10\%$)

Parameters	Description	Test Conditions ⁽¹⁾	Min.	Typ. ⁽²⁾	Max.	Units
V_{CC}	Supply Voltage		2.3		3.6	
$V_{IH}^{(3)}$	Input HIGH Voltage	$V_{CC} = 2.3V$ to $2.7V$	1.7			
		$V_{CC} = 2.7V$ to $3.6V$	2.0			
$V_{IL}^{(3)}$	Input LOW Voltage	$V_{CC} = 2.3V$ to $2.7V$			0.7	
		$V_{CC} = 2.7V$ to $3.6V$			0.8	
$V_{IN}^{(3)}$	Input Voltage		0		V_{CC}	
$V_{OUT}^{(3)}$	Output Voltage		0		V_{CC}	
V_{OH}	Output HIGH Voltage	$I_{OH} = -100\mu\text{A}$, $V_{CC} = \text{Min. to Max.}$	$V_{CC} - 0.2$			
		$V_{IH} = 1.7V$, $I_{OH} = -6\text{mA}$, $V_{CC} = 2.3V$	2.0			
		$V_{IH} = 1.7V$, $I_{OH} = -12\text{mA}$, $V_{CC} = 2.3V$	1.7			
		$V_{IH} = 2.0V$, $I_{OH} = -12\text{mA}$, $V_{CC} = 2.7V$	2.2			
		$V_{IH} = 2.0V$, $I_{OH} = -12\text{mA}$, $V_{CC} = 3.0V$	2.4			
		$V_{IH} = 2.0V$, $I_{OH} = -24\text{mA}$, $V_{CC} = 3.0V$	2.0			
V_{OL}	Output LOW Voltage	$I_{OL} = 100\mu\text{A}$, $V_{IL} = \text{Min. to Max.}$			0.2	
		$V_{IL} = 0.7V$, $I_{OL} = 6\text{mA}$, $V_{CC} = 2.3V$			0.4	
		$V_{IL} = 0.7V$, $I_{OL} = 12\text{mA}$, $V_{CC} = 2.3V$			0.7	
		$V_{IL} = 0.8V$, $I_{OL} = 12\text{mA}$, $V_{CC} = 2.7V$			0.4	
		$V_{IL} = 0.8V$, $I_{OL} = 24\text{mA}$, $V_{CC} = 3.0V$			0.55	
$I_{OH}^{(3)}$	Output HIGH Current	$V_{CC} = 2.3V$			-12	
		$V_{CC} = 2.7V$			-12	
		$V_{CC} = 3.0V$			-24	
$I_{OL}^{(3)}$	Output LOW Current	$V_{CC} = 2.3V$			12	
		$V_{CC} = 2.7V$			12	
		$V_{CC} = 3.0V$			24	



PI74ALVCH162820
3.3V 10-BIT FLIP-FLOP WITH
DUAL OUTPUTS AND 3-STATE OUTPUTS

DC Electrical Characteristics-Continued (Over the Operating Range, $T_A = -40^\circ\text{C}$ to $+85^\circ\text{C}$, $V_{CC} = 3.3\text{V} \pm 10\%$)

Parameters	Description	Test Conditions ⁽¹⁾	Min.	Typ. ⁽²⁾	Max.	Units
I_{IN}	Input Current	$V_{IN} = V_{CC}$ or GND, $V_{CC} = 3.6\text{V}$			± 5	μA
$I_{IN (HOLD)}$	Input Hold Current	$V_{IN} = 0.7\text{V}$, $V_{CC} = 2.3\text{V}$	45			
		$V_{IN} = 1.7\text{V}$, $V_{CC} = 2.3\text{V}$	-45			
		$V_{IN} = 0.8\text{V}$, $V_{CC} = 3.0\text{V}$	75			
		$V_{IN} = 2.0\text{V}$, $V_{CC} = 3.0\text{V}$	-75			
		$V_{IN} = 0$ to 3.6V , $V_{CC} = 3.6\text{V}$			± 500	
I_{OZ}	Output Current (3-STATE Outputs)	$V_{OUT} = V_{CC}$ or GND, $V_{CC} = 3.6\text{V}$			± 10	
I_{CC}	Supply Current	$V_{CC} = 3.6\text{V}$, $I_{OUT} = 0\mu\text{A}$, $V_{IN} = \text{GND}$ or V_{CC}			40	
ΔI_{CC}	Supply Current per Input @ TTL HIGH	$V_{CC} = 3.0\text{V}$ to 3.6V One Input at $V_{CC} - 0.6\text{V}$ Other Inputs at V_{CC} or GND			750	
C_I	Control Inputs	$V_{IN} = V_{CC}$ or GND, $V_{CC} = 3.3\text{V}$		3.5		pF
	Data Inputs			6		
C_O	Outputs	$V_O = V_{CC}$ or GND, $V_{CC} = 3.3\text{V}$		7		

Notes:

1. For conditions shown as Max. or Min., use appropriate value specified under Electrical Characteristics for the applicable device type.
2. Typical values are at $V_{CC} = 3.3\text{V}$, $+25^\circ\text{C}$ ambient and maximum loading.
3. Unused Control Inputs must be held HIGH or LOW to prevent them from floating.

Timing Requirements over Operating Range

Parameters	Description	$V_{CC} = 2.5\text{V} \pm 0.2\text{V}$		$V_{CC} = 2.7\text{V}$		$V_{CC} = 3.3\text{V} \pm 0.3\text{V}$		Units
		Min.	Max.	Min.	Max.	Min.	Max.	
f_{CLOCK}		0	150	0	150	0	150	MHz
t_w	Pulse duration CLK HIGH or LOW	3.3		3.3		3.3		ns
t_{SU}	Setup time, data before CLK \uparrow	1.7		1.8		1.4		
t_{H}	Hold time, data after CLK \uparrow	1.1		1.1		1.0		
$\Delta t/\Delta v^{(3)}$	Input Transition Rise or Fall	0	10	0	10	0	10	ns/V

Note:

1. Unused control inputs must be held HIGH or LOW to prevent them from floating.



PI74ALVCH162820
3.3V 10-BIT FLIP-FLOP WITH
DUAL OUTPUTS AND 3-STATE OUTPUTS

Switching Characteristics over Operating Range⁽¹⁾

Parameters	From (INPUT)	To (OUTPUT)	V _{CC} = 2.5V ± 0.2V		V _{CC} = 2.7V		V _{CC} = 3.3V ± 0.3V		Units
			Min. ⁽²⁾	Max.	Min. ⁽²⁾	Max.	Min. ⁽²⁾	Max. ⁽²⁾	
f _{MAX}			150		150		150		ns
t _{PD}	CLK	Q	1.0	7.0		6.2	1.0	5.4	
t _{EN}	\overline{OE}	Q	1.0	7.4		6.8	1.0	5.6	
t _{DIS}	\overline{OE}	Q	1.3	6.4		5.5	1.0	5.0	

Notes:

1. See test circuit and wave forms.
2. Minimum limits are guaranteed but not tested on Propagation Delays.

Operating Characteristics, T_A = 25°C

Parameter		Test Conditions	V _{CC} = 2.5V ± 0.2V	V _{CC} = 3.3V ± 0.3V	Units
			Typical		
C _{PD} Power Dissipation Capacitance	Outputs Enabled	C _L = 50pF, f = 10 MHz	68	66	pF
	Outputs Disabled		39	47	