

## 5 Amp Low Dropout Positive Voltage Regulator

The PJ1084 Series are high performance positive voltage regulators are designed for use in applications requiring low dropout performance at full rated current. Additionally, the PJ1084 Series provides excellent regulation over variations due to changes in line, load and temperature. Outstanding features include low dropout performance at rated current, fast transient response, internal current limiting and thermal shutdown protection of the output device. The PJ1084 Series are three terminal regulators with fixed and adjustable voltage options available in popular packages.

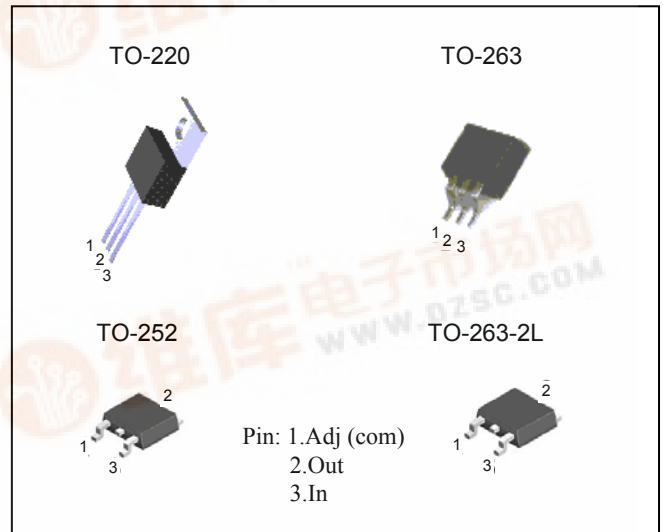

### FEATURES

- Low dropout performance 1.3V max.
- Full current rating over line and temperature
- Fast transient response
- Total output regulation  $\pm 2\%$  over line, load and temperature
- Adjust pin current max  $120 \mu A$  over temperature
- Line regulation typical 0.015%.
- Load regulation typical 0.05%.
- Fixed/adjustable output voltage
- TO-220 & TO-263 & TO-263-2L & TO-252 package

### ORDERING INFORMATION

Device	Operating Temperature (Ambient)	Package
PJ1084CZ PJ1084CZ-2.5 PJ1084CZ-3.3	-20°C to +85°C	TO-220
PJ1084CM PJ1084CM-2.5 PJ1084CM-3.3		TO-263
PJ1084CF PJ1084CF-2.5 PJ1084CF-3.3		TO-263-2L
PJ1084CP PJ1084CP-2.5 PJ1084CP-3.3		TO-252

NOTE: Contact factory for additional voltage option.

### BLOCK

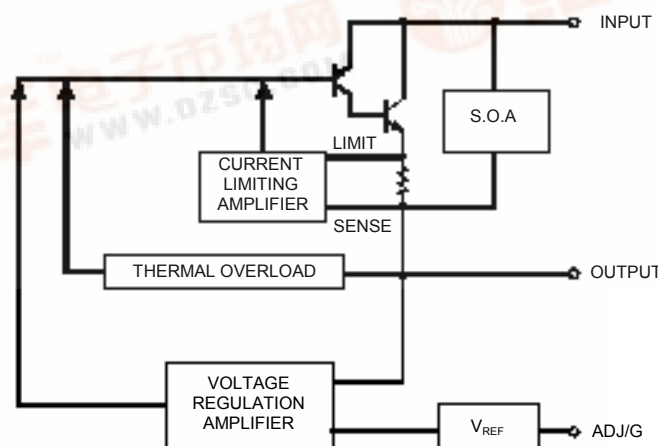

5 Amp Low Dropout Positive Voltage Regulator

**ABSOLUTE MAXIMUM RATING**

Parameter	Symbol	Maximum	Units
Input Voltage	V <sub>IN</sub>	12	V
Power Dissipation	P <sub>D</sub>	Internally Limited	W
Thermal Resistance Junction to Case	θ <sub>JC</sub>	2.5	°C/W
Thermal Resistance Junction to Ambient	θ <sub>JA</sub>	50	
Operating Junction Temperature Range	T <sub>J</sub>	0 to +125	°C
Operating Ambient Temperature Range	T <sub>A</sub>	-20 to +85	
Storage Temperature Range	T <sub>STG</sub>	-25 to 150	
Lead Temperature (Soldering) 10 Sec.	T <sub>LEAD</sub>	260	

**ELECTRICAL CHARACTERISTICS**

Unless otherwise specified, Adjust V<sub>IN</sub> = 2.75V to 12V and Adjust I<sub>O</sub> = 10mA to 5.0A  
 Fixed V<sub>IN</sub> = 4.75V to 12V and Fixed I<sub>O</sub> = 10mA to 5.0A

Parameter	Symbol	Test Conditions			Test Limits			Units	
		V <sub>IN</sub> -V <sub>OUT</sub>	I <sub>O</sub>	T <sub>J</sub> <sup>(4)</sup>	Min	Typ	Max		
Output Voltage <sup>(1)</sup> Fixed Voltage	V <sub>O</sub>	5V	10mA	25	0.99 V <sub>O</sub>	V <sub>O</sub>	1.01 V <sub>O</sub>	V	
				Over Temp.	0.98 V <sub>O</sub>		1.02 V <sub>O</sub>		
Reference Voltage <sup>(1)</sup> Adj Voltage	V <sub>REF</sub>	5V	10mA	25	1.238	1.250	1.262		
				Over Temp.	1.225		1.275		
Line Regulation <sup>(1)</sup> (V <sub>in</sub> -V <sub>out</sub> =3V)	REG <sub>(LINE)</sub>		10mA	25			0.015	0.2	%
				Over Temp.			0.035		
Load Regulation <sup>(1)</sup> (V <sub>in</sub> -V <sub>out</sub> =3V)	REG <sub>(LOAD)</sub>		25	0.05			0.3		
			Over Temp.	0.2			0.4		
Dropout Voltage ΔV <sub>REF</sub> =1%	V <sub>D</sub>			25			1		V
							1.1	1.3	
Current Limit (V <sub>in</sub> -V <sub>out</sub> =5V)	I <sub>CL</sub>				5.5		6.5		A
				Over Temp.					
Quiescent Current Fixed Model	I <sub>Q</sub>	5V					12	14	mA
Temperature Coefficient	T <sub>c</sub>						0.005		%/°C
Adjust Pin Current	I <sub>ADJ</sub>			25			55		μA
								120	
Adjust Pin Current Change	ΔI <sub>ADJ</sub>						0.2	5	
Temperature Stability	T <sub>S</sub>	5V	500mA	Over Temp.			0.5		%
Minimum Load Current Adjust Model	I <sub>O</sub>	5V					5	10	mA
RMS Output Noise <sup>(2)</sup>	V <sub>N</sub>			25			0.003		%V <sub>O</sub>
Ripple Rejection Ratio <sup>(3)</sup>	R <sub>A</sub>	5V	5.0A	Over Temp.	60		72		dB

(1)Low duty cycle pulse testing with Kelvin connections required.  
 (2)Bandwidth of 10Hz to 10KHz.  
 (3)120Hz input ripple (C<sub>ADJ</sub> for ADJ)=25μF .  
 (4)Over Temp.-over specified operating junction temperature range.

5 Amp Low Dropout Positive Voltage Regulator

Typical Application Circuit

FIXED VOLTAGE REGULATOR (1)(2)

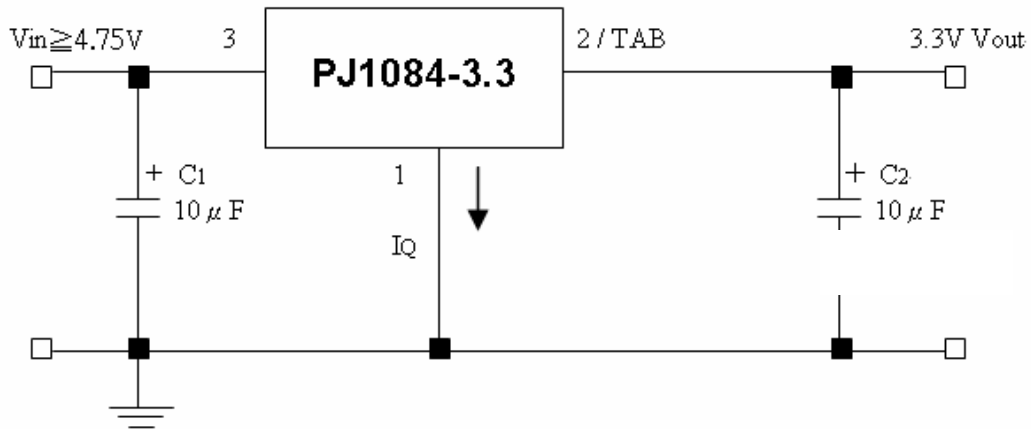

- (1) C1 NEEDED IF DEVICE IS FAR FROM FILTER CAPACITORS
- (2) C2 REQUIRED FOR STABILITY

ADJUSTABLE VOLTAGE REGULATOR (1)(2)

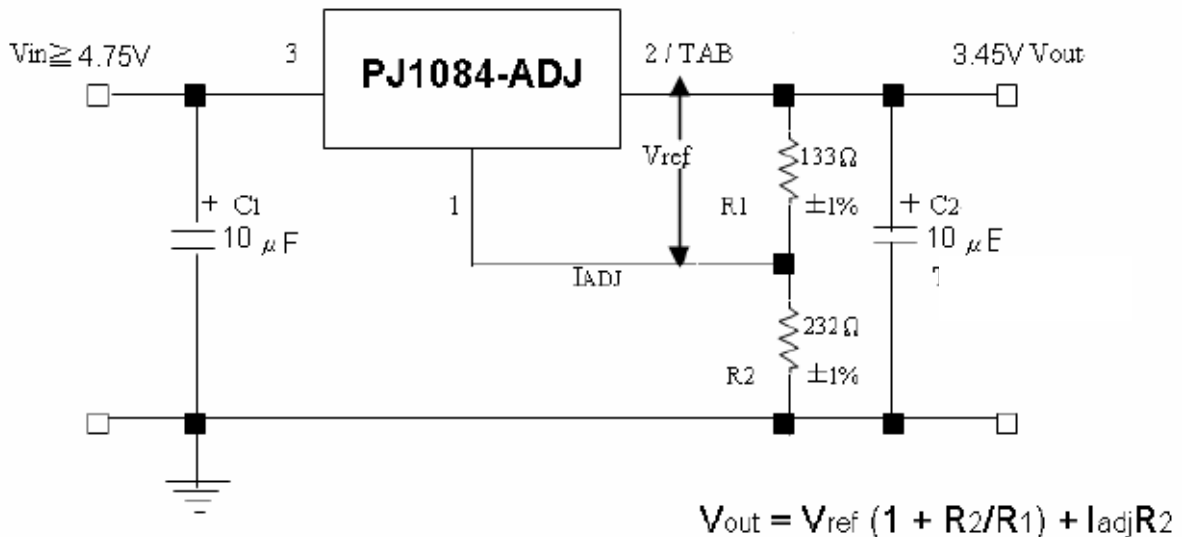

- (1) C1 NEEDED IF DEVICE IS FAR FROM FILTER CAPACITORS
- (2) C2 REQUIRED FOR STABILITY

5 Amp Low Dropout Positive Voltage Regulator

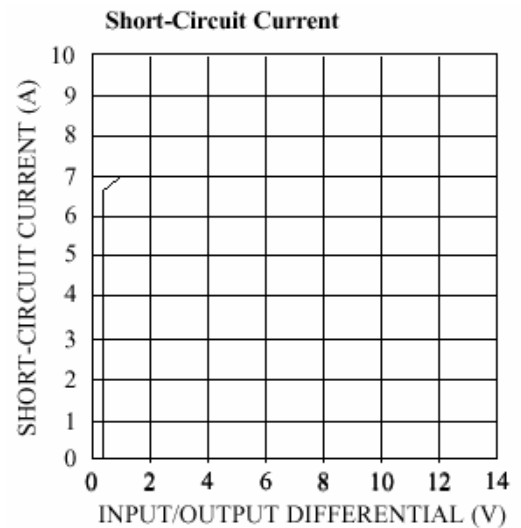
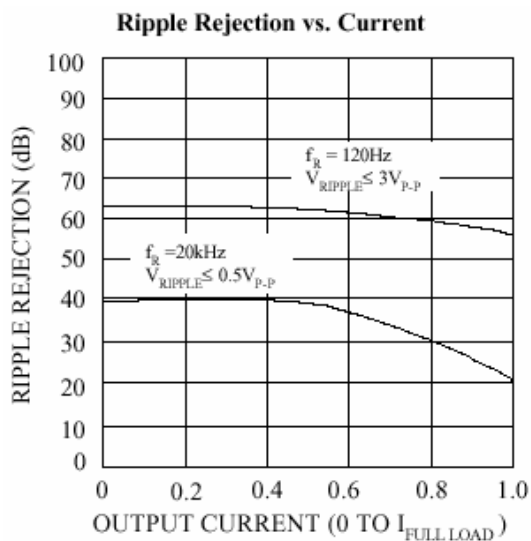
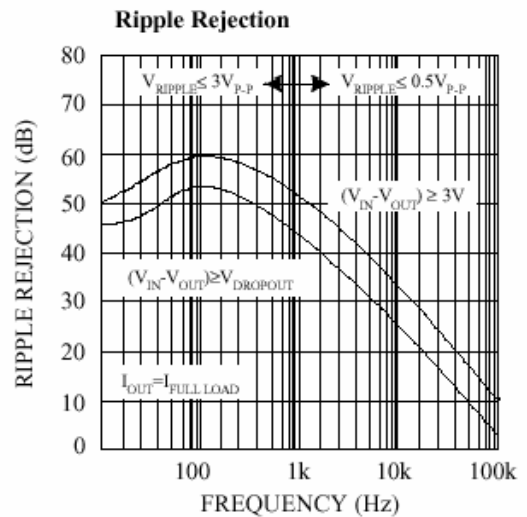
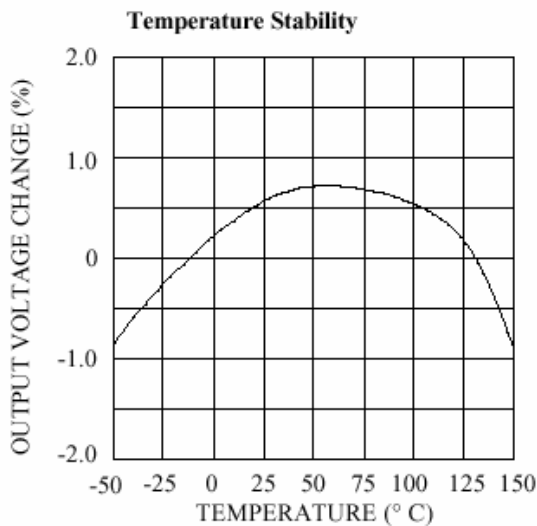
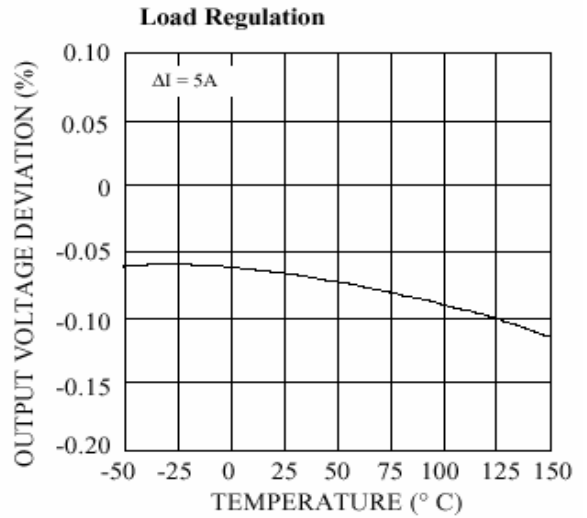
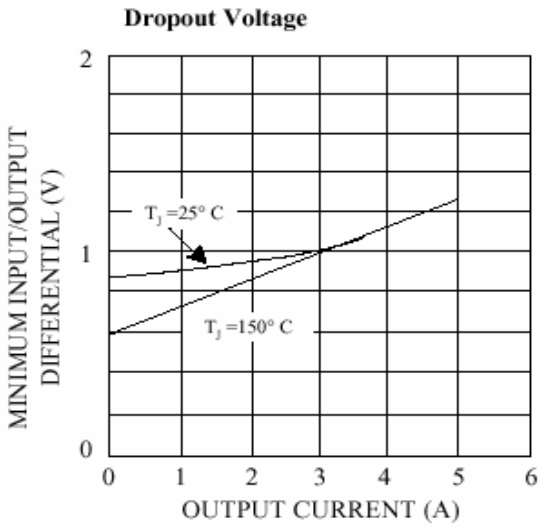

5 Amp Low Dropout Positive Voltage Regulator

Load Transient Response

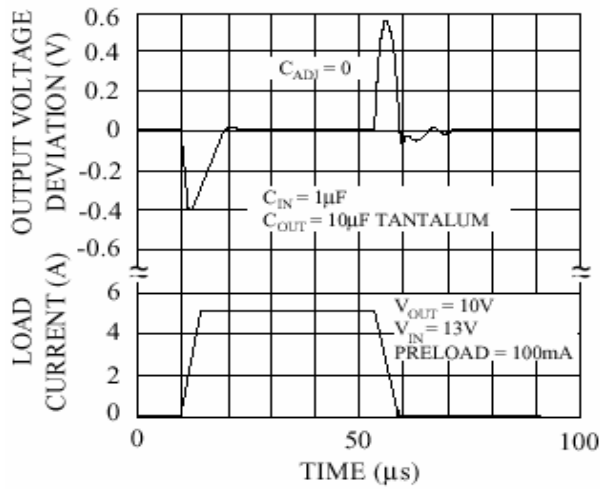

Line Transient Response

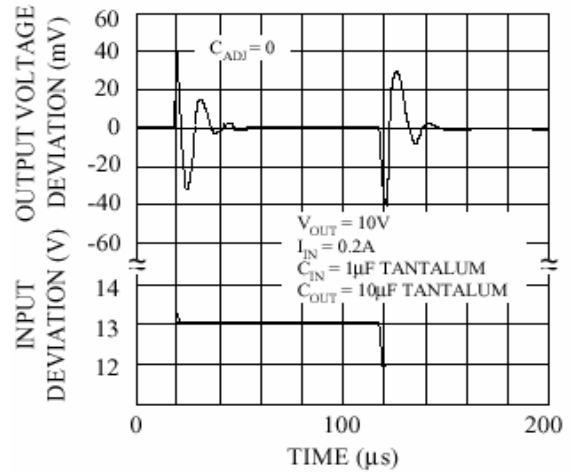

Maximum Power Dissipation\*

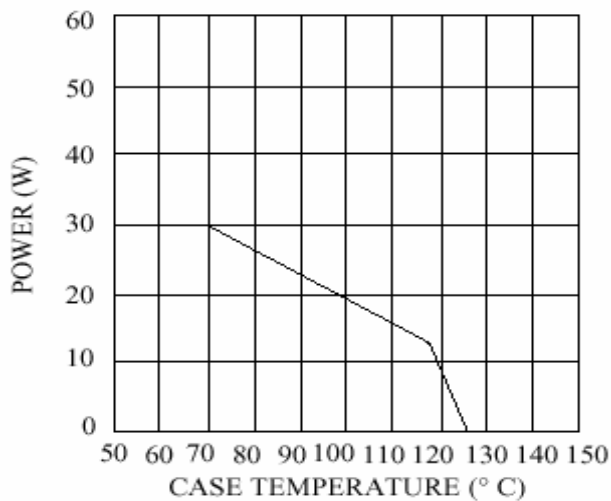

\*AS LIMITED BY MAXIMUM JUNCTION TEMPERATURE

Minimum Operating Current (Adjustable only)

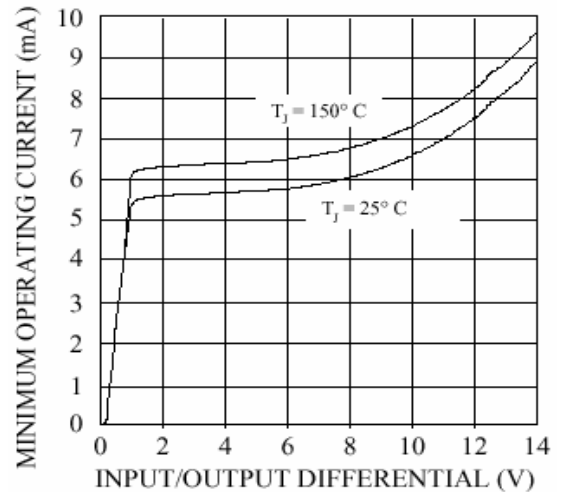

Adjust Pin Current (Adjustable only)

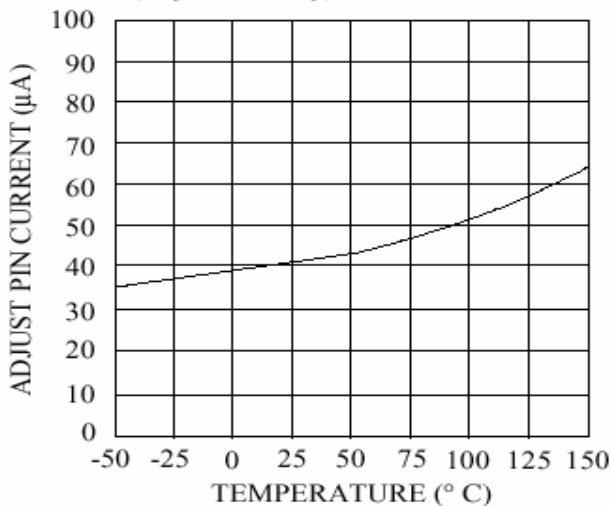

5 Amp Low Dropout Positive Voltage Regulator

TO-220 Mechanical drawing

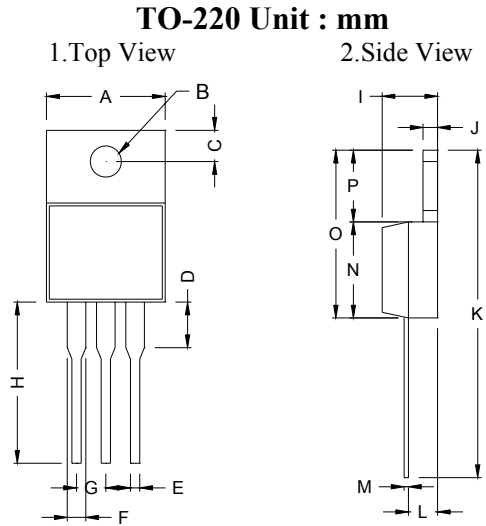

TO-220 DIMENSION				
DIM	MILLIMETERS		INCHES	
	MIN	MAX	MIN	MAX
A	10.00	10.50	0.394	0.413
B	3.24	4.44	0.128	0.175
C	2.44	2.94	0.096	0.116
D	3.565	4.315	0.140	0.170
E	0.68	0.92	0.027	0.036
F	1.115	1.485	0.044	0.058
G	2.345	2.715	0.092	0.107
H	13.49	14.31	0.531	0.563
I	4.475	5.225	0.176	0.206
J	1.15	1.39	0.045	0.055
K	27.78	29.62	1.094	1.166
L	2.175	2.925	0.086	0.115
M	0.297	0.477	0.012	0.019
N	8.28	8.80	0.326	0.346
O	14.29	15.31	0.563	0.603
P	6.01	6.51	0.237	0.256

TO-263 Mechanical drawing

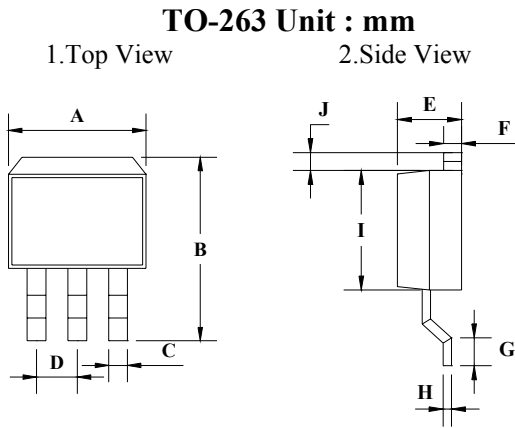

TO-263 DIMENSION				
DIM	MILLIMETERS		INCHES	
	MIN	MAX	MIN	MAX
A	10.00	10.50	0.394	0.413
B	14.60	15.87	0.575	0.625
C	0.68	0.92	0.027	0.036
D	2.42	2.66	0.095	0.105
E	4.31	4.83	0.170	0.190
F	1.14	1.40	0.045	0.055
G	2.28	2.79	0.090	0.110
H	0.45	0.73	0.018	0.029
I	8.28	8.80	0.326	0.346
J	1.14	1.4	0.045	0.055

5 Amp Low Dropout Positive Voltage Regulator

TO-252 Mechanical drawing

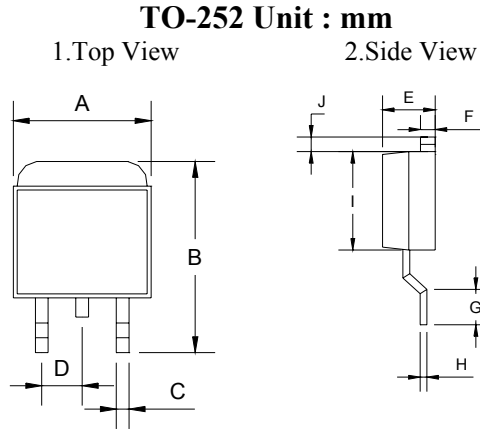

TO-252 DIMENSION				
DIM	MILLIMETERS		INCHES	
	MIN	MAX	MIN	MAX
A	6.57	6.84	0.259	0.269
B	9.25	10.40	0.364	0.409
C	0.62	0.76	0.024	0.030
D	2.56	2.67	0.101	0.105
E	2.30	2.39	0.090	0.094
F	0.49	0.57	0.019	0.022
G	1.46	1.58	0.057	0.062
H	0.52	0.57	0.020	0.022
I	5.34	5.55	0.210	0.219
J	1.46	1.64	0.057	0.065

TO-263-2L Mechanical drawing

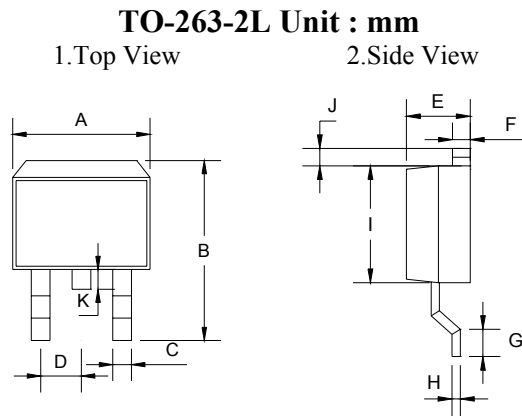

TO-263-2L DIMENSION				
DIM	MILLIMETERS		INCHES	
	MIN	MAX	MIN	MAX
A	10.00	10.50	0.394	0.413
B	14.60	15.58	0.575	0.625
C	0.68	0.92	0.027	0.036
D	2.42	2.66	0.095	0.105
E	4.31	4.83	0.170	0.190
F	1.14	1.40	0.045	0.055
G	2.28	2.79	0.090	0.110
H	0.45	0.73	0.018	0.029
I	8.28	8.80	0.326	0.346
J	1.14	1.40	0.045	0.055
K	1.48	1.52	0.058	0.060