

SIEMENS



ICs for Communications

Mixer/Amplifier

PMB 2333 Version 1.2

Preliminary Data Sheet 09.97

T2333-XV12-P3-7600

Edition 09.97

Published by Siemens AG,
Bereich Halbleiter, Marketing-
Kommunikation, Balanstraße 73,
81541 München

© Siemens AG 1995.
All Rights Reserved.

Attention please!

As far as patents or other rights of third parties are concerned, liability is only assumed for components, not for applications, processes and circuits implemented within components or assemblies.

The information describes the type of component and shall not be considered as assured characteristics.

Terms of delivery and rights to change design reserved.

For questions on technology, delivery and prices please contact the Semiconductor Group Offices in Germany or the Siemens Companies and Representatives worldwide (see address list).

Due to technical requirements components may contain dangerous substances. For information on the types in question please contact your nearest Siemens Office, Semiconductor Group.

Siemens AG is an approved CECC manufacturer.

Packing

Please use the recycling operators known to you. We can also help you – get in touch with your nearest sales office. By agreement we will take packing material back, if it is sorted. You must bear the costs of transport.

For packing material that is returned to us unsorted or which we are not obliged to accept, we shall have to invoice you for any costs incurred.

Components used in life-support devices or systems must be expressly authorized for such purpose!

Critical components¹ of the Semiconductor Group of Siemens AG, may only be used in life-support devices or systems² with the express written approval of the Semiconductor Group of Siemens AG.

- 1 A critical component is a component used in a life-support device or system whose failure can reasonably be expected to cause the failure of that life-support device or system, or to affect its safety or effectiveness of that device or system.
- 2 Life support devices or systems are intended (a) to be implanted in the human body, or (b) to support and/or maintain and sustain human life. If they fail, it is reasonable to assume that the health of the user may be endangered.

Ausgabe 09.97

Herausgegeben von Siemens AG,
Bereich Halbleiter, Marketing-
Kommunikation, Balanstraße 73,
81541 München

© Siemens AG 1995.
Alle Rechte vorbehalten.

Wichtige Hinweise!

Gewähr für die Freiheit von Rechten Dritter leisten wir nur für Bauelemente selbst, nicht für Anwendungen, Verfahren und für die in Bauelementen oder Baugruppen realisierten Schaltungen.

Mit den Angaben werden die Bauelemente spezifiziert, nicht Eigenschaften zugesichert.

Liefermöglichkeiten und technische Änderungen vorbehalten.

Fragen über Technik, Preise und Liefermöglichkeiten richten Sie bitte an den Ihnen nächstgelegenen Vertrieb Halbleiter in Deutschland oder an unsere Landesgesellschaften im Ausland.

Bauelemente können aufgrund technischer Erfordernisse Gefahrstoffe enthalten. Auskünfte darüber bitten wir unter Angabe des betreffenden Typs ebenfalls über den Vertrieb Halbleiter einzuholen.

Die Siemens AG ist ein Hersteller von CECC-qualifizierten Produkten.

Verpackung

Bitte benutzen Sie die Ihnen bekannten Verwerter. Wir helfen Ihnen auch weiter – wenden Sie sich an Ihren für Sie zuständigen Vertrieb Halbleiter. Nach Rücksprache nehmen wir Verpackungsmaterial sortiert zurück. Die Transportkosten müssen Sie tragen.

Für Verpackungsmaterial, das unsortiert an uns zurückgeliefert wird oder für das wir keine Rücknahmepflicht haben, müssen wir Ihnen die anfallenden Kosten in Rechnung stellen.

Bausteine in lebenserhaltenden Geräten oder Systemen müssen ausdrücklich dafür zugelassen sein!

Kritische Bauelemente¹ des Bereichs Halbleiter der Siemens AG dürfen nur mit ausdrücklicher schriftlicher Genehmigung des Bereichs Halbleiter der Siemens AG in lebenserhaltenden Geräten oder Systemen² eingesetzt werden.

- 1 Ein kritisches Bauelement ist ein in einem lebenserhaltenden Gerät oder System eingesetztes Bauelement, bei dessen Ausfall berechtigter Grund zur Annahme besteht, daß das lebenserhaltende Gerät oder System ausfällt bzw. dessen Sicherheit oder Wirksamkeit beeinträchtigt wird.
- 2 Lebenserhaltende Geräte und Systeme sind (a) zur chirurgischen Einpflanzung in den menschlichen Körper gedacht, oder (b) unterstützen bzw. erhalten das menschliche Leben. Sollten sie ausfallen, besteht berechtigter Grund zur Annahme, daß die Gesundheit des Anwenders gefährdet werden kann.

PMB 2333		
Revision History:		Current Version: 09.97
Previous Version:		06.96
Page (in 06.96 Version)	Page (in new Version)	Subjects (major changes since last revision)
10	10	Supply Voltage -> 5.0V max.
10	10	Input Voltage $V_{LO/X}$ -> 5.0V max.
10	10	Input Voltage V_{AI} -> $V_{AO}+0.3V$ max.
	10	Input Voltage V_{AI} AC Peak -> -2V min.
10	10	Input Voltage V_{GC} -> -0.3V min. / $V_S+0.3$ max.
10	10	Input Voltage V_{STB} -> 5.0V max.
10	10	Open Collector Output Voltage $V_{MO/X}$ ->1.7V min. / 5.0V max.
	10	Amplifier Current (Base, Peak) I_{AI} -> 6mA
	10	Amplifier Power dissipation P_{AMPtot} -> 105mW
10	11	Thermal Resistance R_{thJA} -> 213K/W
	11	Thermal Resistance R_{thSO} -> 160K/W
	11	ESD Integrity
25	26	Amplifier $f=0.9GHz$ -> Γ_{OPT}
26	27	Amplifier $f=1.8GHz$ -> Γ_{OPT}
32	33	Diagram 5 - Identical Values - New Printout
		Update Of / Additional Application Information
		Correction Of Printing Mistakes

PMB 2333		
Revision History:		Current Version: 06.96
Previous Version:		11.95
Page (in 11.95 Version)	Page (in 06.96 Version)	Subjects (major changes since last revision)
		Update of RF/S-parameters because of cavity change, correction of printing mistakes, update of application circuits

Table of Contents		Page
1	Overview5
1.1	Functional Description, Benefits5
1.2	Applications5
1.3	Pin Configuration6
1.4	Pin Definitions and Functions7
1.5	Functional Block Diagram8
1.6	Circuit Description9
2	Electrical Characteristics10
2.1	Absolute Maximum Ratings10
2.2	Operational Range12
2.3	AC/DC Characteristics13
2.4	Test Circuits19
3	Application Data34
3.1	Receiver Application34
3.1.1	Shortform Data34
3.1.2	Measurement results36
3.1.3	Application hint - Mixer metrics versus mixer current40
3.1.4	Circuit diagram and PCB layout43
3.2	Upconversion Application48
3.2.1	Shortform Data48
3.2.2	Measurement results49
3.2.3	Circuit diagram and PCB layout51
3.3	Receiver/SAW Application57
3.3.1	Shortform Data57
3.3.2	System calculations59
3.3.3	Measurement results61
3.3.4	Circuit diagram and PCB layout63
4	Package Outlines69

SIEMENS

Mixer/Amplifier

PMB 2333

Version 1.2

Bipolar IC

1 Overview

1.1 Functional Description, Benefits

- New B6HF bipolar technology, 25GHz f_T
- Small outline P-TSSOP 16 package
- Reduced external components
- Frequency range up to 3.0GHz
- Amplifier may be used as LNA or Driver
- LNA mode
 - 1.7dB typ. noise figure at 1.8GHz
 - 5mA typ. current consumption
- Driver mode
 - +12dBm output at 1dB compression
 - 20mA current consumption
- Gilbert cell mixer with high gain
- 2.7 - 4.5V voltage supply
- -40°C to +85°C operational temperature range
- Standby function
- High isolation values for amplifier and mixer
- Good crosstalk performance

1.2 Applications

- Cellular radio systems
- Cordless telephone systems
- WLAN-Systems

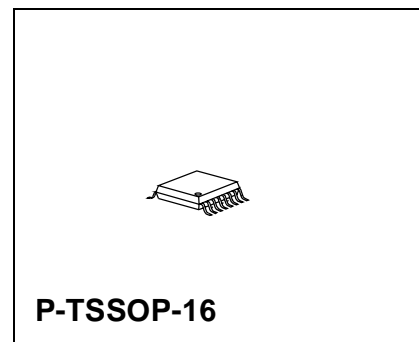

Type	Version	Ordering Code	Package
PMB 2333	V1.2	Q67006-A6128	P-TSSOP-16

1.3 Pin Configuration

(top view)

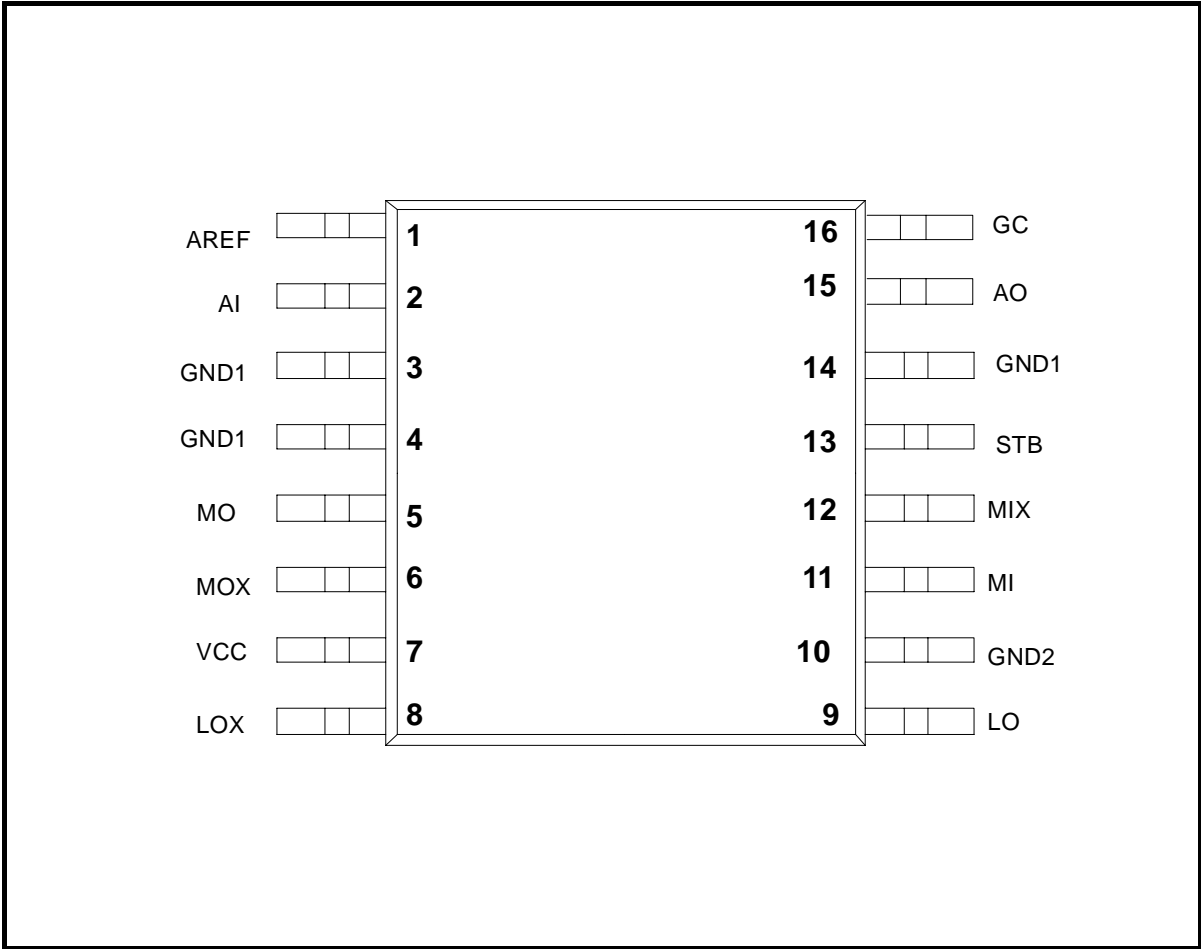

P-TSSOP16

1.4 Pin Definitions and Functions

Pin No.	Symbol	Function
1	AREF	Amplifier bias supply for signal input
2	AI	Amplifier signal base input
3	GND1	Amplifier ground
4	GND1	Amplifier ground
5	MO	Mixer signal open collector output
6	MOX	Mixer signal open collector output
7	VCC	Voltage supply total circuit
8	LOX	Mixer local oscillator signal base input, inverted
9	LO	Mixer local oscillator signal base input, not inverted
10	GND2	Mixer ground
11	MI	Mixer signal emitter input, not inverted
12	MIX	Mixer signal emitter input, inverted
13	STB	Standby mixer and bandgap
14	GND1	Amplifier ground
15	AO	Amplifier signal open collector output
16	GC	Amplifier gain control

1.5 Functional Block Diagram

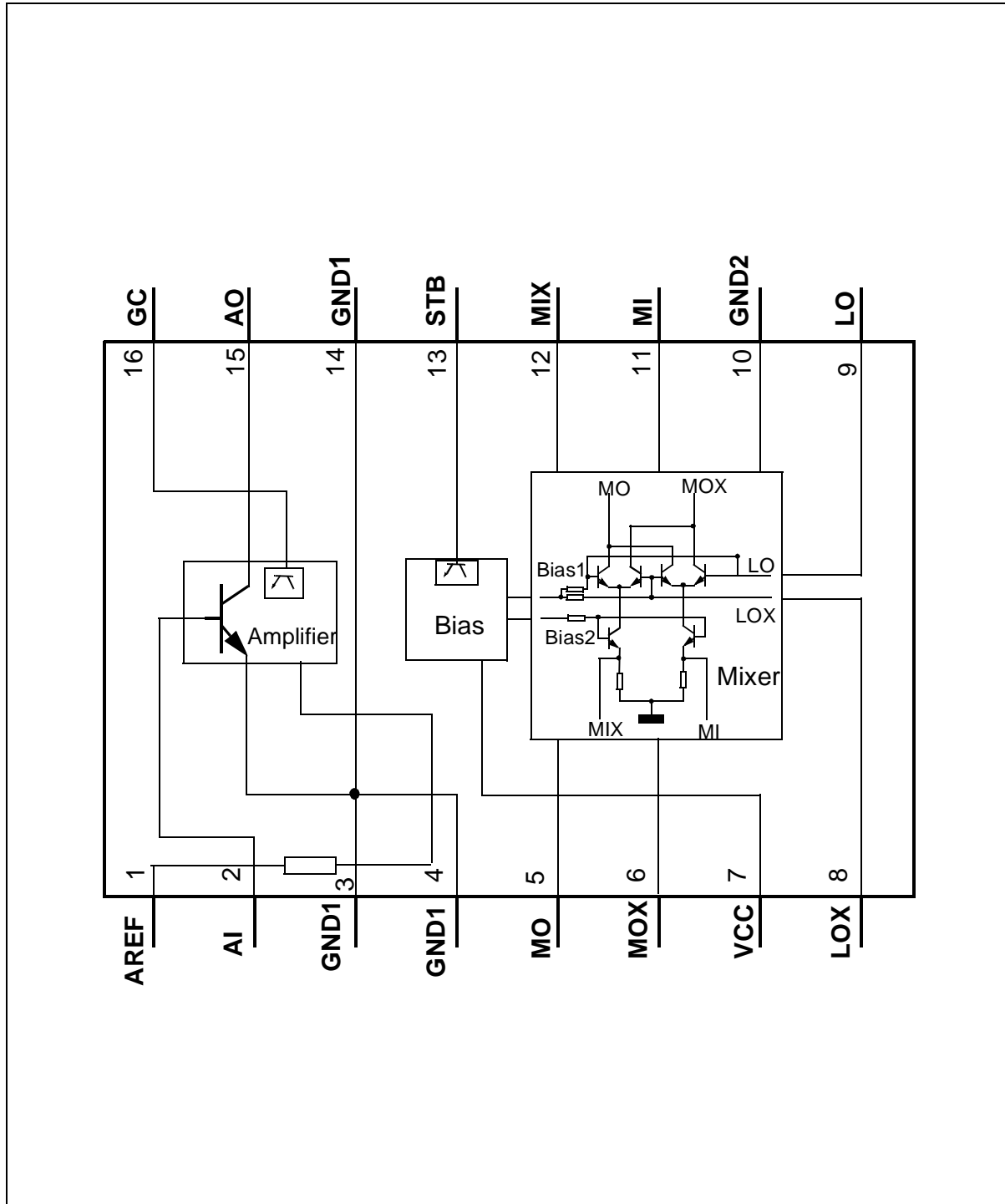

1.6 Circuit Description

MIXER

The mixer used in this design is a general purpose up-/down conversion gilbert cell mixer. Via the pins MI/MIX the RF enters the IC. Using an external supplied local oscillator at LO/LOX a converted output signal is created at the open collector output pins MO/MOX. The open collector pins need to be connected to an external voltage supply. The RF connection to the mixer inputs can be single ended or balanced, capacitive or inductive. To improve the mixer performance external resistors at MI/MIX make it possible to adjust the mixer current. Voltage supply for the mixer has to be connected to the pin VCC and to GND2.

AMPLIFIER

The amplifier may be used as a low noise amplifier LNA or as a driver. At pin AI the RF signal enters the IC, at the open collector output AO, which need to be connected to supply voltage, the amplified signal is external available for further use. Matching networks at in-/and output can be used for improving the gain and the noise performance. To reduce the series feedback of the emitter line the amplifier is connected to ground via three GND1 pins. At AREF a internal supplied reference voltage is available for the DC biasing of AI. This dc output should be implemented in an input matching network. The voltage supply for the amplifier is also VCC. The dc-level at the pin GC allows to adjust the amplifier current.

Lower current is recommended for using the amplifier as an LNA, high current for using it as a driver.

COMMON

Differential signals and symmetrical circuits are used throughout the mixer part of the IC. An internal bias driver generates supply voltage and temperature compensated reference voltages. The STB pin allows the mixer and bandgap part of the IC to be switched in a low power mode.

All pins with the exception of GND1,2 and AI/AO are ESD protected.

2 Electrical Characteristics

2.1 Absolute Maximum Ratings

The maximum ratings may not be exceeded under any circumstances, not even momentarily and individually, as permanent damage to the IC will result.

Ambient temperature $T_{amb} = -40^{\circ}\text{C} \dots +85^{\circ}\text{C}$

#	Parameter	Symbol	Limit Values		Units	Remarks
			Min	Max		
1	Supply Voltage	V_S	-0.3	5.0	V	
2a	Input Voltage	$V_{MI/MIX}$	-0.3	1.9	V	$V_S = 0$
2b	Input Voltage	$V_{LO/LOX}$	0.6	$V_S+0.3$ 5.0max.	V V	
2c	Input Voltage	V_{AI}	-0.3	$V_{AO}+0.3$ 3.5max.	V V	
2d	Input Voltage (AC Peak)	V_{AI}	-2		V	Freq.>1MHz $I_{AI} < nA$
2e	Input Voltage	V_{GC}	-0.3	$V_S+0.3$ 2.7max.	V V	
2f	Input Voltage	V_{STB}	-0.3	$V_S+0.3$ 5.0max.	V V	
3a	Output Voltage	V_{AREF}	-0.3	2.0	V	
3b	Open Collector Output Voltage	$V_{MO/MOX}$	1.7	$V_S+0.3$ 5.0max.	V V	
3c	Open Collector Output Voltage	V_{AO}	-0.3	3.5	V	Base open
3d	Open Collector Output Voltage	V_{AO}	-0.3	7.0	V	$R_B < 50k\Omega$
4a	Amplifier Current (Collector)	I_{AO}		30	mA	
4b	Amplifier Current (Base, Peak)	I_{AI}		6.0	mA	DC and AC
4c	Amplifier Power Dissipation	P_{AMPtot}		105	mW	
5	Differential Input Voltage	V_{DIFF}		2.0	V_{PP}	
6	Junction Temperature	T_j		125	$^{\circ}\text{C}$	

Absolute Maximum Ratings

The maximum ratings may not be exceeded under any circumstances, not even momentarily and individually, as permanent damage to the IC will result.

Ambient temperature $T_{amb} = -40^{\circ}\text{C} \dots +85^{\circ}\text{C}$

#	Parameter	Symbol	Limit Values		Units	Remarks
			Min	Max		
7	Storage Temperature	T_S	-40	125	$^{\circ}\text{C}$	
8a	Thermal Resistance	R_{thJA}		213	K/W	1)
8b	Thermal Resistance	R_{thSO}		160	K/W	2)
9	ESD integrity, all pins without AI,AO and GND1/2	V_{ESD}	-500	500	V	3)

1) Attention: **Do not exceed the max. junction temperature**

2) Junction to soldering point, simulated with FEM

3) HBM according MIL STD 883D, method 3015.7, and EOS/ESD assn. standard S5.1-1993

2.2 Operational Range

Within the operational range the IC operates as described in the circuit description. The AC/DC characteristic limits are not guaranteed.

Supply voltage $V_{VCC} = 2.7V...4.5V$, Ambient temperature $T_{amb} = -40^{\circ}C...85^{\circ}C$

#	Parameter	Symbol	Limit Values		Units	Remarks
			Min	Max		
1	AI Input Frequency	f_{AI}		3000	MHz	
2	MI/X Input Frequency	f_{MI}		3000	MHz	
3	LO/X Input Frequency	f_{LO}		3000	MHz	
4	IF Intermediate Frequency	f_{IF}		3000	MHz	
5	Standby Voltage On	STB_{ON}	2.0	V_S	V	
6	Standby Voltage Off	STB_{OFF}	0	0.5	V	
7	Gain Control Voltage, High	GC_{High}	2.0	2.7	V	Diagram 5
8	Gain Control Voltage, Low	GC_{Low}	0	0.6	V	Diagram 5

Note: Power levels refer to 50 Ohms impedance

2.3 AC/DC Characteristics

AC/DC characteristics involve the spread of values guaranteed within the specified supply voltage and ambient temperature range. Typical characteristics are the median of the production.

Supply voltage $V_{VCC} = 2.7V \dots 4.5V$, Ambient temperature $T_{amb} = +25^{\circ}C$

#	Parameter	Symbol	Limit Values			Units	Test Conditions	Test Circuit
			Min	Typ	Max			

Supply Current

1a	Supply current, total IC	$I_{5,6,7,15}$		23.6		mA	STB ON, no external resistors at MI/MIX*	1, $I_{AO}=20$ mA
1b	Supply current, total IC	$I_{5,6,7,15}$		1.6		mA	STB ON, no external resistors at MI/MIX*	1, $I_{AO}=0$ mA
2	Supply current, total IC	$I_{5,6,7,15}$		<20		μA	STB OFF, GC=0V	1

* Minimum value for external resistors at MI/MIX: $R1=R2=330\Omega$

AC/DC Characteristics

AC/DC characteristics involve the spread of values guaranteed within the specified supply voltage and ambient temperature range. Typical characteristics are the median of the production.

Supply voltage $V_{VCC} = 2.7V$ to $4.5V$, Ambient temperature $T_{amb} = +25^{\circ}$

#	Parameter	Symbol	Limit Values			Unit	Test Conditions	Test Circuit
			Min	Typ	Max			

AMPLIFIER-Driver, Signal Input AI, $I_{AO}=20mA$, $V_{AO}=3.3V$, $f=2.5GHz$

3	Input impedance, vs. freq.	S_{11}					Diagram 3a	3
4	Max. input level, 1db compression	P_{AI}		0.0		dbm	f=2.5GHz	1
5	Input intercept, third order	$IICP_{DAI}$		10.0		dbm	f=2.5GHz	1

AMPLIFIER-Driver, Signal Output AO, $I_{AO}=20mA$, $V_{AO}=3.3V$, $f=2.5GHz$

6	Output current	I_{AO}		20.0		mA		1
7	Output impedance vs. freq.	S_{22}					Diagram 3a	3
8	Power gain	S_{21Amp}		+12.5		db	f=2.5GHz	1

AMPLIFIER-Driver, Signal Input AI, $I_{AO}=0mA$, $V_{AO}=3.3V$, $f=2.5GHz$

9	Input impedance, vs. freq.	S_{11}					Diagram 3c	3
10	Max. input level, 1db change	P_{AI}		0.0		dbm	f=2.5GHz	1
11	Input intercept, third order	$IICP_{AI}$		20.0		dbm	f=2.5GHz	1

AMPLIFIER-Driver, Signal Output AO, $I_{AO}=0mA$, $V_{AO}=3.3V$, $f=2.5GHz$

12	Output current	I_{AO}		0		mA		1
13	Output impedance vs. freq.	S_{22}					Diagram 3c	3
14	Power gain	S_{21Amp}		< -13		db	f=2.5GHz	1

All amplifier measurements have be done with Siemens RT5880 Duroid (Teflon) Boards

AC/DC Characteristics

AC/DC characteristics involve the spread of values guaranteed within the specified supply voltage and ambient temperature range. Typical characteristics are the median of the production.

Supply voltage $V_{VCC} = 2.7V$ to $4.5V$, Ambient temperature $T_{amb} = +25^{\circ}$

#	Parameter	Symbol	Limit Values			Unit	Test Conditions	Test Circuit
			Min	Typ	Max			

AMPLIFIER-LNA, Signal Input AI, $I_{AO}=5mA$, $V_{AO}=3.3V$, $f=1.8GHz$

15	Input impedance, vs. freq.	S_{11}					Diagram 3b	3
16	Max. input level, 1dB compression	P_{AI}		-12.0		dBm	f=1.8GHz	1
17	Input intercept, third order	$IICP_{AI}$		1.0		dBm	f=1.8GHz	1
18	Noise figure	F_{AI}		1.7		dB	f=1.8GHz	1

AMPLIFIER-LNA, Signal Output AO, $I_{AO}=5mA$, $V_{AO}=3.3V$, $f=1.8GHz$

19	Output current	I_{AO}		5.0		mA		1
20	Output impedance vs. freq.	S_{22}					Diagram 3b	3
21	Power gain	S_{21LNA}		12.0		dB	f=1.8GHz	1

AMPLIFIER-LNA, Signal Input AI, $I_{AO}=0mA$, $V_{AO}=3.3V$, $f=1.8GHz$

22	Input impedance, vs. freq.	S_{11}					Diagram 3c	3
23	Max. input level, 1db change	P_{AI}		0.0		dbm	f=1.8GHz	1
23	Input intercept, third order	$IICP_{AI}$		20.0		dbm	f=1.8GHz	1

AMPLIFIER-LNA, Signal Output AO, $I_{AO}=0mA$, $V_{AO}=3.3V$, $f=1.8GHz$

24	Output current	I_{AO}		0		mA		1
25	Output impedance vs. freq.	S_{22}					Diagram 3c	3
26	Power gain	S_{21A}		< -17		db	f=1.8GHz	1

All LNA measurements have be done with Siemens RT5880 Duroid (Teflon) Boards

AC/DC Characteristics

AC/DC characteristics involve the spread of values guaranteed within the specified supply voltage and ambient temperature range. Typical characteristics are the median of the production.

Supply voltage $V_{VCC} = 2.7V$ to $4.5V$, Ambient temperature $T_{amb} = +25^{\circ}$

#	Parameter	Symbol	Limit Values			Unit	Test Conditions	Test Circuit
			Min	Typ	Max			

MIXER, Signal Input MI/MIX, Upconversion, R1,2=330hm

27	Input impedance vs .freq.	Z_{MI}					Diagram 4a	4
28	Max. input level, 1 db compression	P_{MI}		-7		dbm	$f_{MI}=0.66GHz$	1*
29	Input intercept point	$IICP3_{MI}$		6		dbm	$f_{MI}=0.66GHz$	1*

MIXER, Local Oscillator Input LO/LOX, Upconversion, R1,2=330hm

30	Input impedance vs freq.	Z_{LO}					Diagram 4c	4
31	Input level	P_{LO}		0		dbm	$f_{LO}=2.0GHz$	1*

MIXER, Signal Output MO/MOX, $f_{out} = 2.66GHz$, Upconversion, R1,2=330hm

32	Output current	$I_{MO/X}$		10.4		mA	with ext. resistors at MI/MIX	1*
33	Output resistance	R_{MODiff}		600		Ohm	$f_{MO}=2.66GHz$	
34	Output capacitance	C_{MODiff}		0.57		pF	$f_{MO}=2.66GHz$	
35	Power gain	P_{MI}		8		db	$f_{MO}=2.66GHz$	1*

MIXER, Isolation Between In-/Output, $f_{out} = 2.66GHz$, Upconversion, R1,2=330hm

37	LO to MO	A_{LO-MO}		30		db		1*
38	LO to MI	A_{LO-MI}		35		db		1*
39	MO to MI	A_{MO-MI}		40		db		1*
40	MO to LO	A_{MO-LO}		45		db		1*

* MI/MO Input/Output including matching network

AC/DC Characteristics

AC/DC characteristics involve the spread of values guaranteed within the specified supply voltage and ambient temperature range. Typical characteristics are the median of the production.

Supply voltage $V_{VCC} = 2.7V$ to $4.5V$, Ambient temperature $T_{amb} = +25^\circ$

#	Parameter	Symbol	Limit Values			Unit	Test Conditions	Test Circuit
			Min	Typ	Max			

MIXER, Signal Input MI/MIX, Downconversion, R1,2=180Ohm

41	Input impedance vs .freq.	Z_{MI}					Diagram 4b	4
42	Max. input level, 1 db compression	P_{MI}		-15		dBm	f=0.9GHz	2a
43	at MO/MOX, IF=45MHz	P_{MI}		-14		dBm	f=1.8GHz	2a
44		P_{MI}		-9		dBm	f=2.5GHz	2a
45	Input intercept point,	$IICP3_{MI}$		0		dBm	f=0.9GHz	2a
46	$\Delta f=800kHz$, IF= 45MHz	$IICP3_{MI}$		-1		dBm	f=1.8GHz	2a
47		$IICP3_{MI}$		+5		dBm	f=2.5GHz	2a
48	Blocking level,	$P_{in,unwan.}$		-16		dBm	f=0.9GHz	2a
49	$\Delta f=800kHz$, IF=45MHz	$P_{BL,unwan.}$		-16		dBm	f=1.8GHz	2a
50	$P_{in, wanted} = -20dBm$	$P_{BL,unwan.}$		-10		dBm	f=2.5GHz	2a
51	Noise figure, ssb	F_{MI}		9		dB	f=0.9GHz	*
52	(NF _{ssb} ≈NF _{dsb} +3dB)	F_{MI}		11		dB	f=1.8GHz	*
53	IF=45MHz	F_{MI}		14		dB	f=2.5GHz	*

MIXER, Local Oscillator Input LO/LOX, Downconversion, R1,2=180Ohm

54	Input impedance vs freq.	Z_{LO}					Diagram 4d	4
55	Input level	P_{LO}		-3		dBm	f=0.9GHz	2a, **
56		P_{LO}		-3		dBm	f=1.8GHz	2a, **
57		P_{LO}		-3		dBm	f=2.5GHz	2a, **

* matching network used

** referenced for specified mixer performance

AC/DC Characteristics

AC/DC characteristics involve the spread of values guaranteed within the specified supply voltage and ambient temperature range. Typical characteristics are the median of the production.

Supply voltage $V_{VCC} = 2.7V$ to $4.5V$, Ambient temperature $T_{amb} = +25^{\circ}$

#	Parameter	Symbol	Limit Values			Unit	Test Conditions	Test Circuit
			Min	Typ	Max			

MIXER, Signal Output MO/MOX, Downconversion, R1,2=180Ohm

58	Output current	I_{MO+MOX}		4.0		mA	incl. R1,R2	
59	Output resistance	R_{MODiff}		32		kOhm	IF=45MHz	2a
60		R_{MODiff}		25		kOhm	IF=300MHz	2b
61	Output capacitance	C_{MODiff}		0.36		pF	IF=45MHz	2a
62		C_{MODiff}		0.39		pF	IF=300MHz	2b
63	Power gain, IF=45MHz	P_{MI}		15		db	f=0.9GHz	2a
64		P_{MI}		14		db	f=1.8GHz	2a
65		P_{MI}		9		db	f=2.5GHz	2a
66	Power gain, IF=300MHz	P_{MI}		7		db	f=0.9GHz	2b
67		P_{MI}		7		db	f=1.8GHz	2b
68		P_{MI}		2.5		db	f=2.5GHz	2b

MIXER, Isolation Between In-/Output, 0.9GHz, Downconversion, R1,2=180Ohm

69	MI to MO	A_{MI-MO}		50		db	$f_{MI}=945MHz,$ $f_{LO}=900MHz$	2a
70	LO to MO	A_{LO-MO}		40		db	“	2a
71	LO to MI	A_{LO-MI}		35		db	“	2a
72	MO to MI	A_{MO-MI}		60		db	“	2a
73	MO to LO	A_{MO-LO}		60		db	“	2a

2.4 Test Circuits

Test Circuit 1

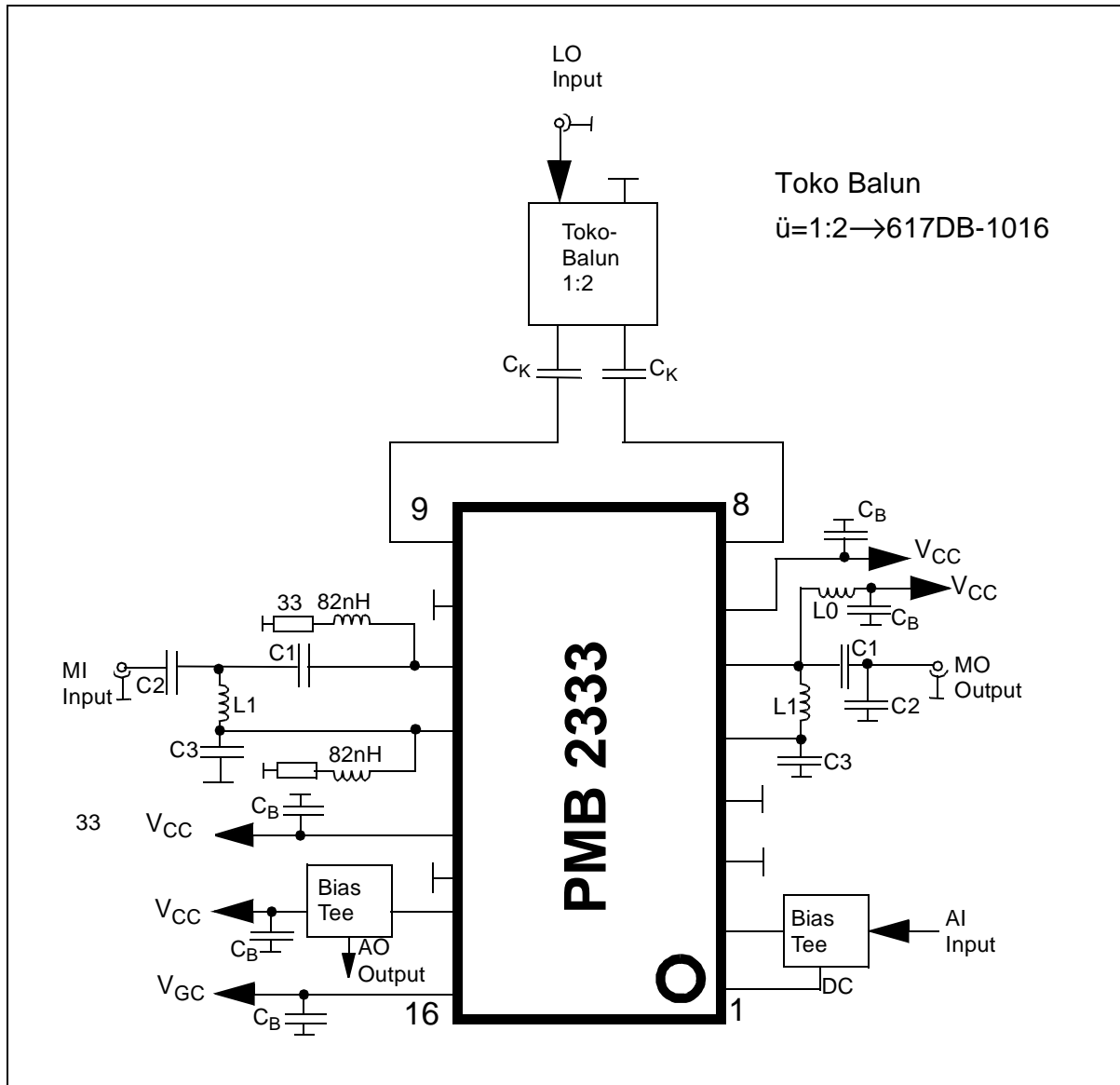

Mixer/Driver Amplifier, Upconversion mode

Test Circuit	f_{IF} [MHz]	L1[nH]	C1[pF]	C2[pF]	C3[pF]	C_K [pF]
1/MI	≈660	8.2	4.7	56	10	15
1/MO	≈2660	2.7	1.8	1.2	1	X

Test Circuit 2a

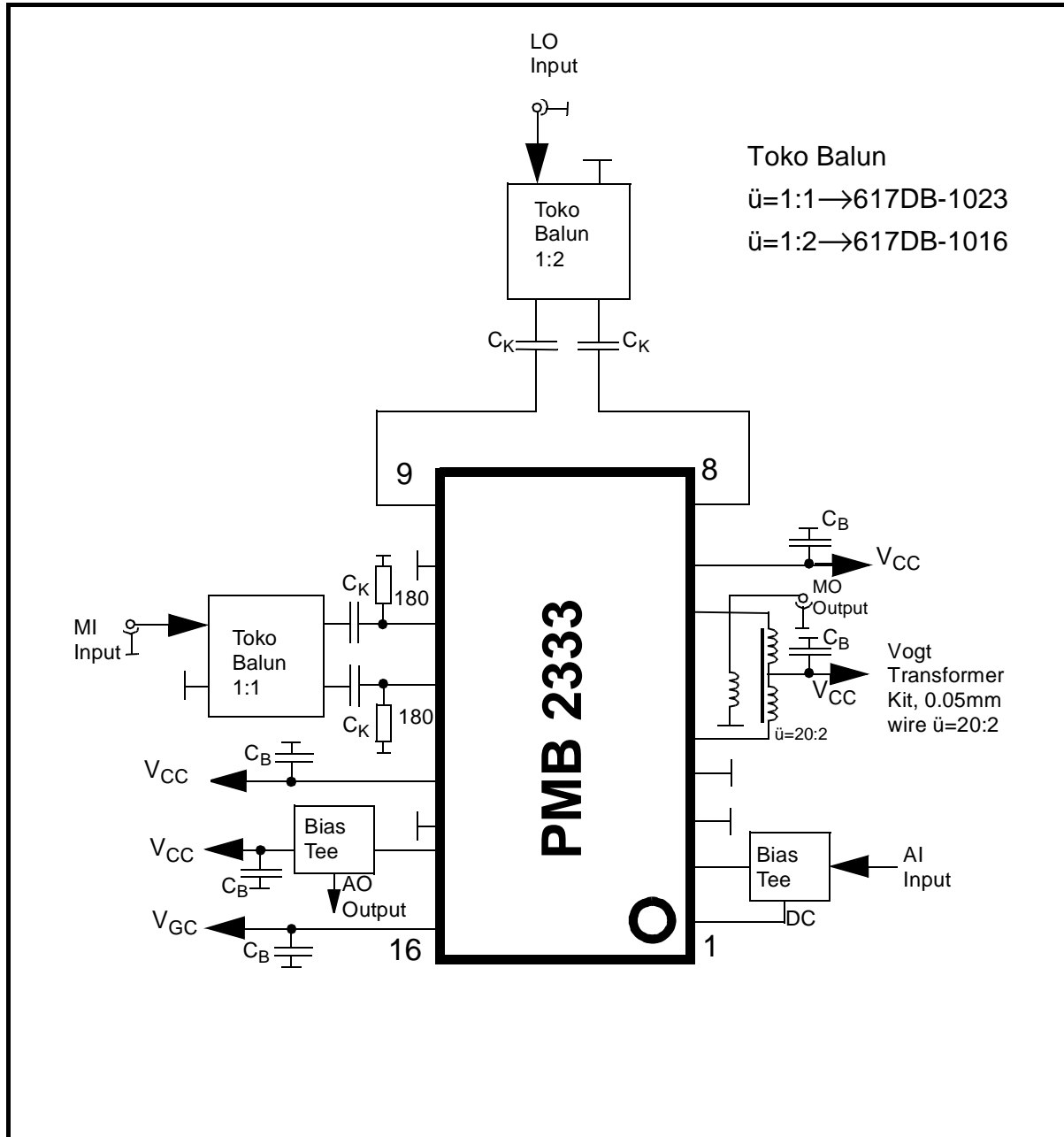

Mixer/Driver Amplifier, Downconversion mode

Test Circuit	f_{IF} [MHz]	C_B [pF]	C_K [pF]	X	X
2a	45	15/100	15	X	X

Test Circuit 2b

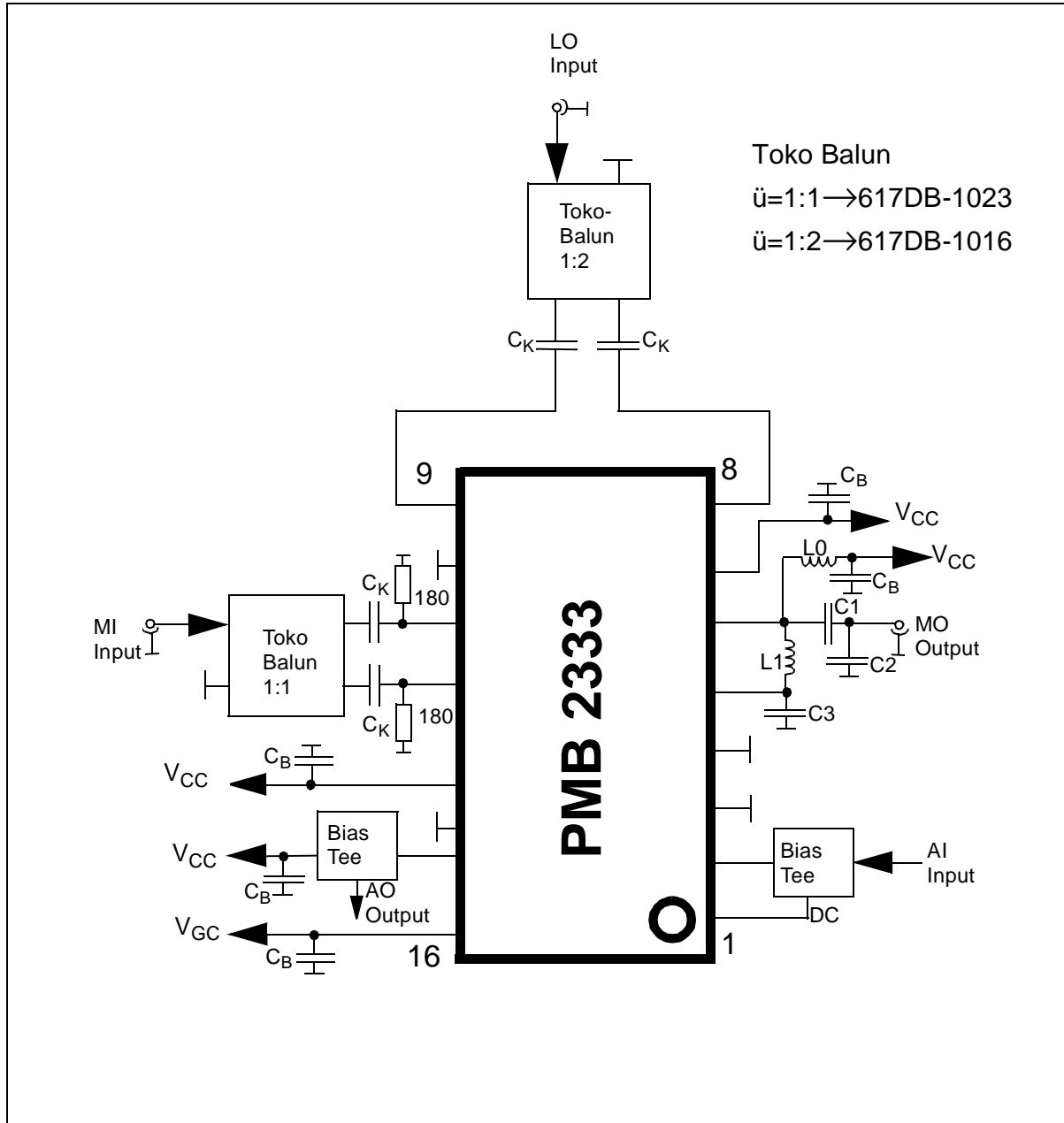

Mixer/Driver Amplifier, Downconversion mode

Test Circuit	f_{IF} [MHz]	L0[nH]	L1[nH]	C1[pF]	C2[pF]	C3[pF]	C_K [pF]
2b	≈ 300	680	150	2.7	12	1.8	15p

Test Circuit 3

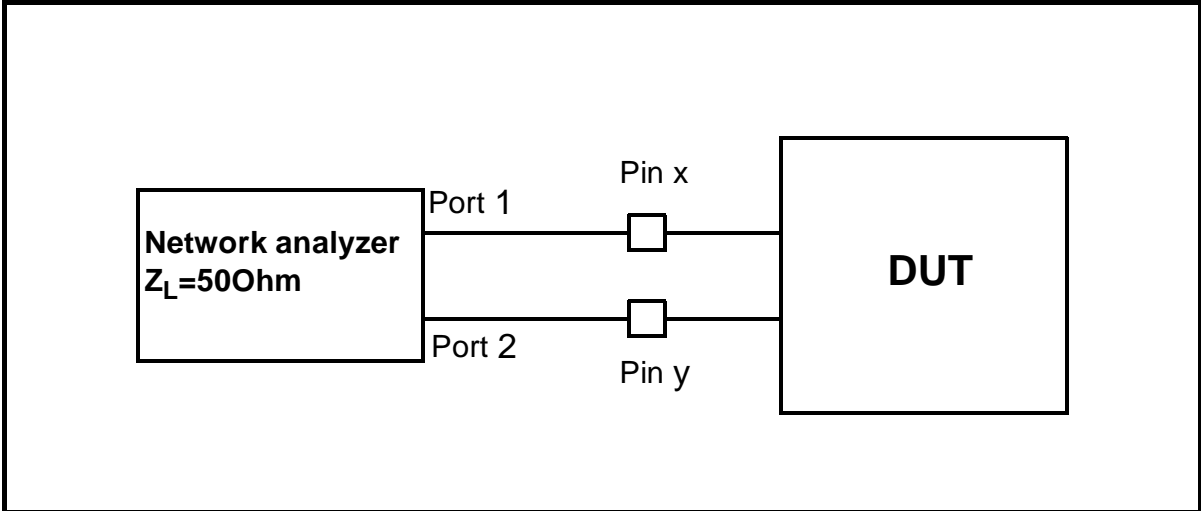

**S-Parameter Measurement of Amplifier
S11, S12, S21, S22**

The S-Parameters are tested at the indicated frequency on Duroid 5880 Teflon Boards.

Via the NWA the capacitive coupling is done.
The output levels at port1 and 2 for pin x and y are -30dbm.

S11 and S22 have to be considered as design hints and are measured with SIEMENS testboards.

Test	Test frequency MHz	Pin X	Pin Y
Amp.S11, S12, S21, S22	30 - 3000	AI	AO

Diagram 3a
 S-Parameter Amplifier $I_{AO}=20mA$, $V_{CC}=3.3V$, $f=30-3000MHz$

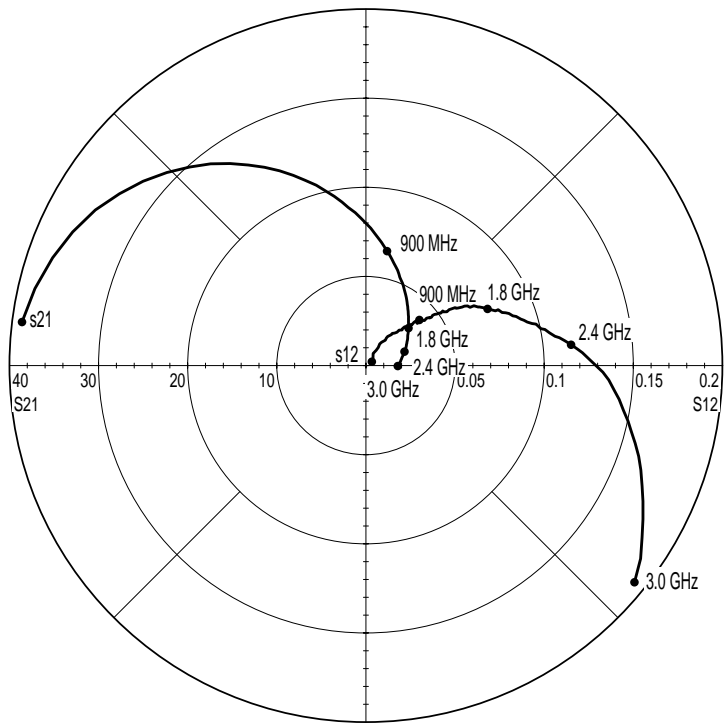
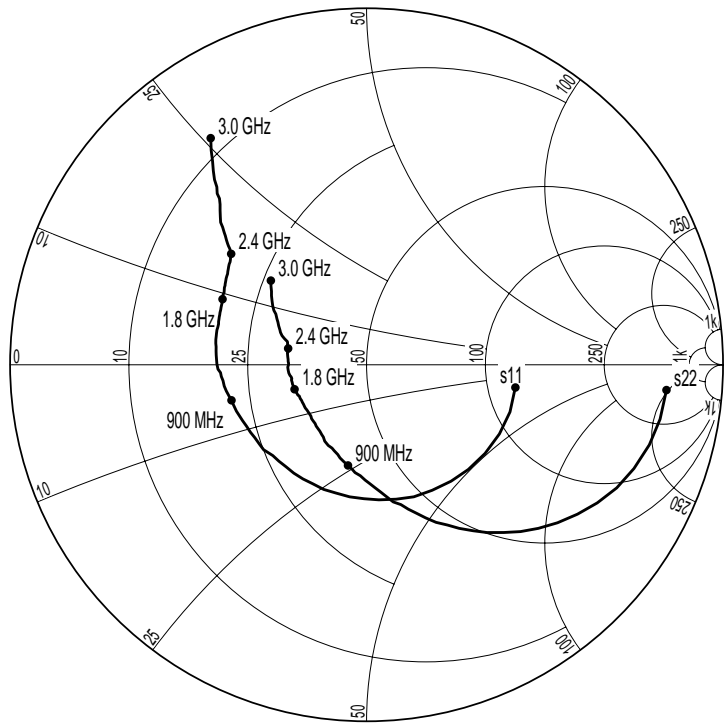
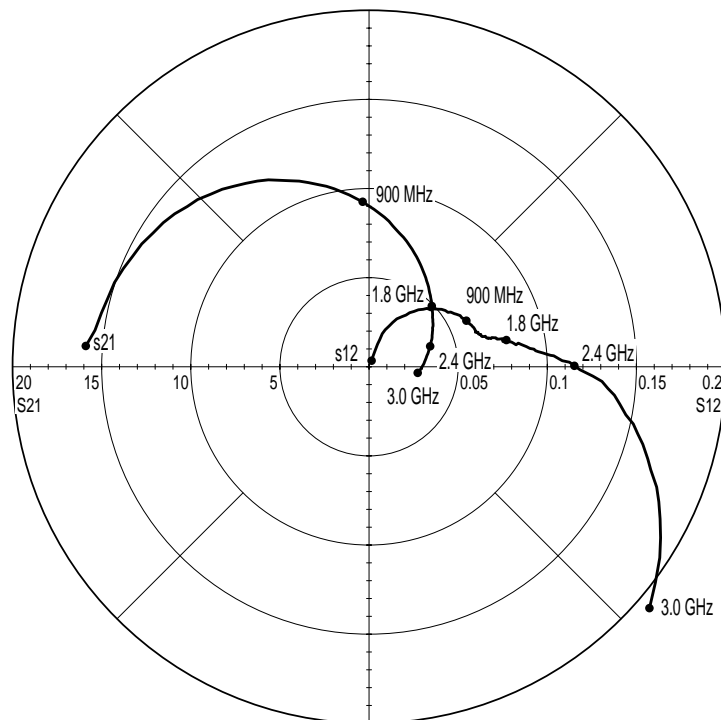
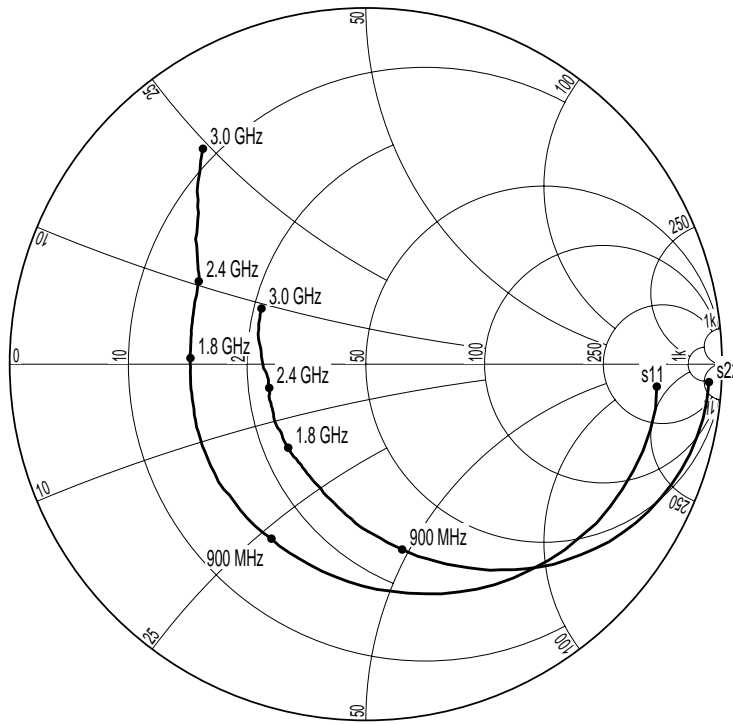

Diagram3b
 S-Parameter Amplifier $I_{AO}=5mA$, $V_{CC}=3.3V$, $f=30-3000MHz$



S-Parameter Amplifier $I_{AO}=0mA$, $V_{CC}=3.3V$, $f=30-3000MHz$

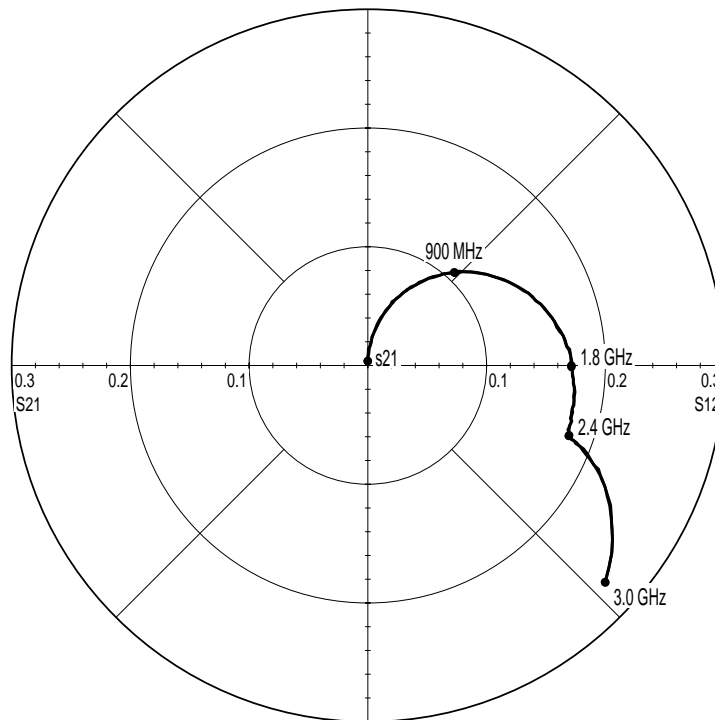
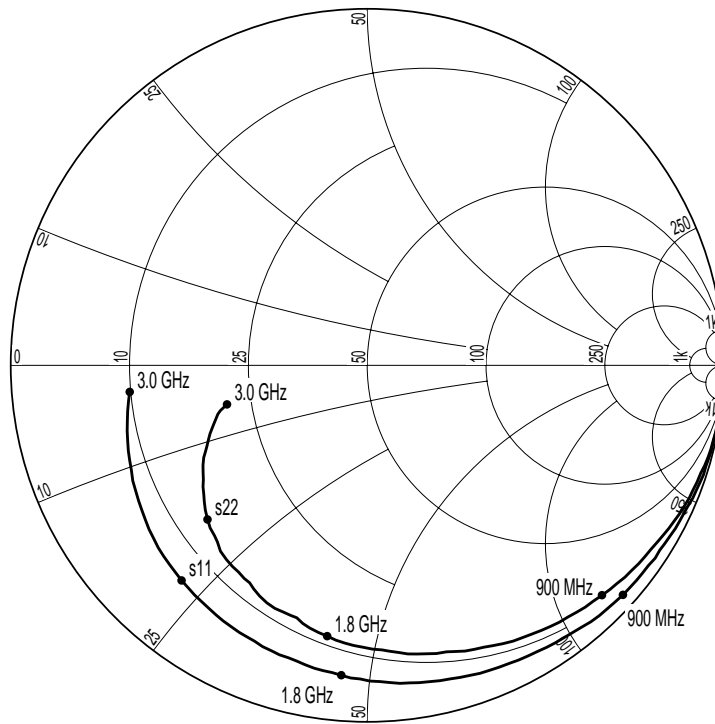
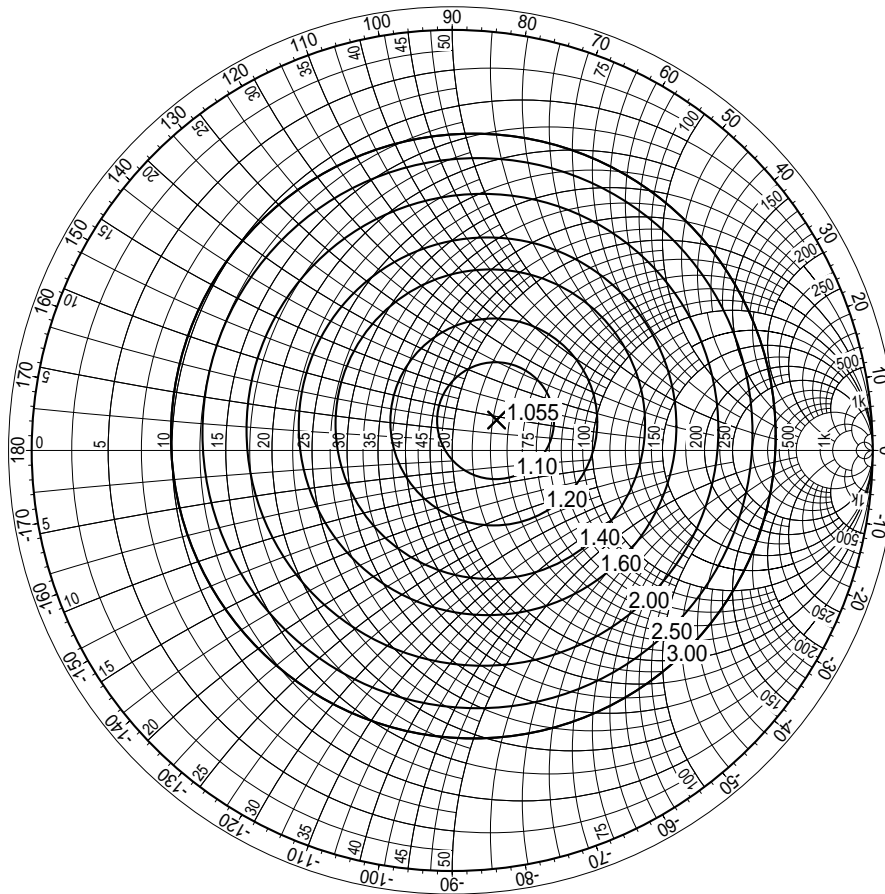
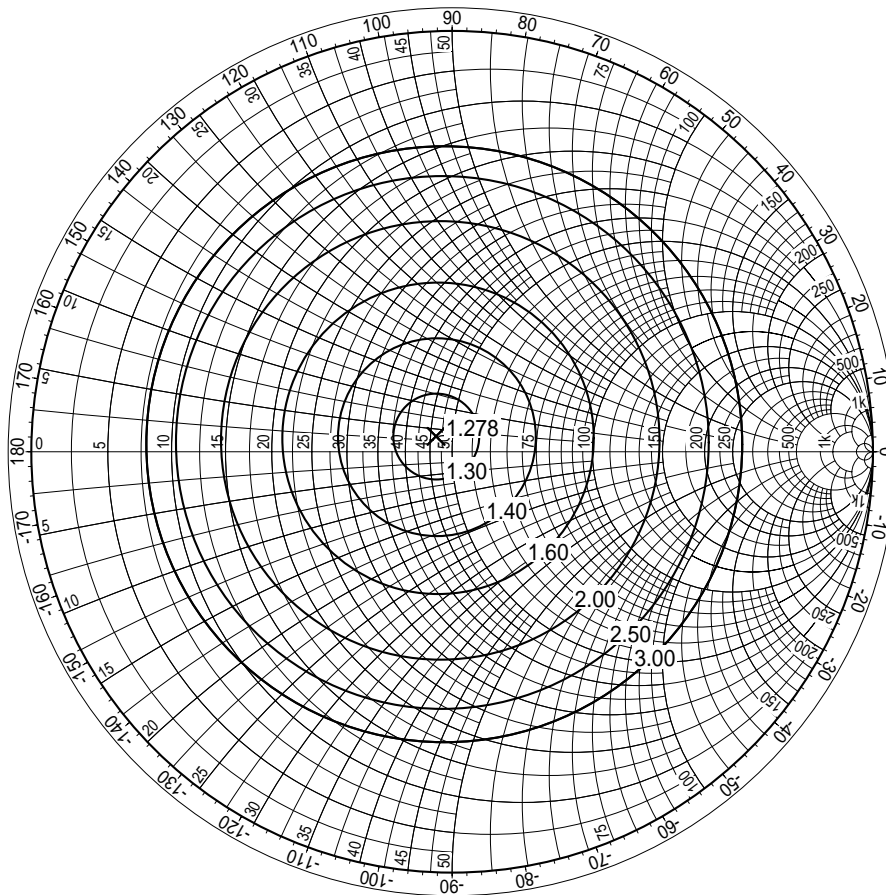

Diagram 3d
Noise Circles Amplifier $I_{AO}=5mA, V_{CC}=3.3V; f=0.9GHz$



$F_{MIN} = 1.055dB$
 $R_n = 10.17\Omega$
 $G_{OPT} = 16.01mS$
 $B_{OPT} = -2.36mS$
 $\Gamma_{OPT} = 0.128 \exp(j 34.4^\circ)$

Diagram 3e
Noise Circles Amplifier $I_{AO}=5mA, V_{CC}=3.3V; f=1.8GHz$



$F_{MIN} = 1.278dB$

$R_n = 7.52\Omega$

$G_{OPT} = 21.54mS$

$B_{OPT} = -1.59mS$

$\Gamma_{OPT} = 0.053 \exp(j 136.2^\circ)$

Test Circuit 4

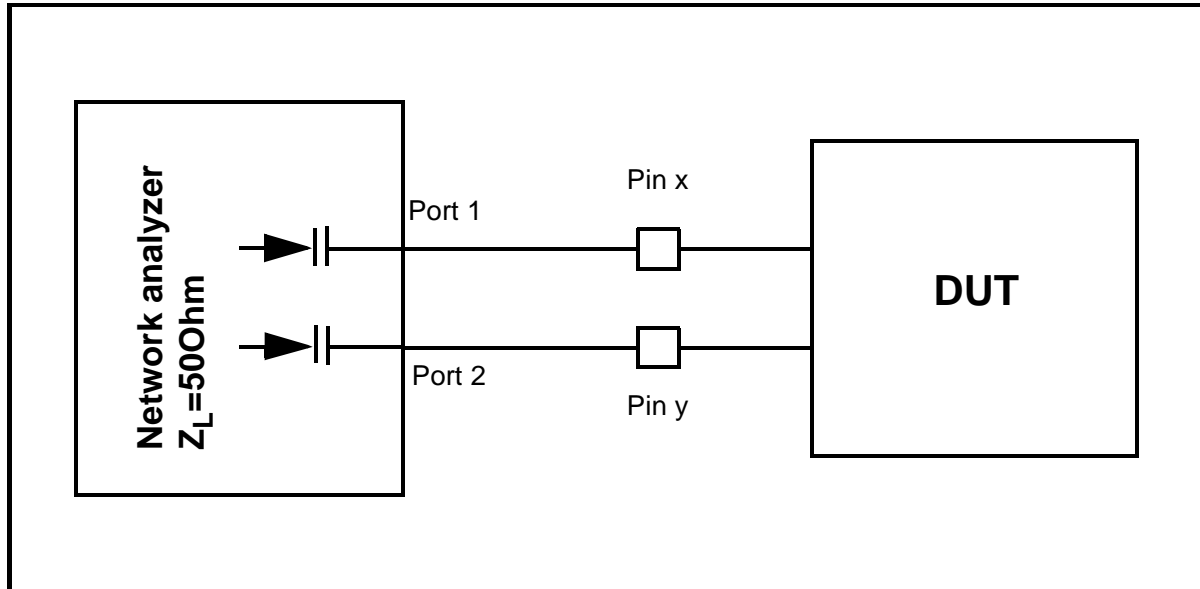

**S-Parameter Measurement of Mixer
S11, S12, S21, S22**

Test	Test Frequency [MHz]	Pin X	Pin Y
LO-Input impedance	30 - 3000	8	9
Mi-Input impedance	30 - 3000	11	12
MO-Output impedance	30 - 3000	5	6

The S-Parameters are tested at the indicated frequency and the equivalent parallel or series circuit is calculated on this base.

Via the NWA the capacitive coupling is done and the open collector pins are connected to VCC. The output levels at port1 and 2 for pin x and y are -30dbm for MI and MO-impedances and -5dbm for the LO impedance. S-Parameters have to be considered as design hints and are measured with SIEMENS testboards.

Test Circuit 4a

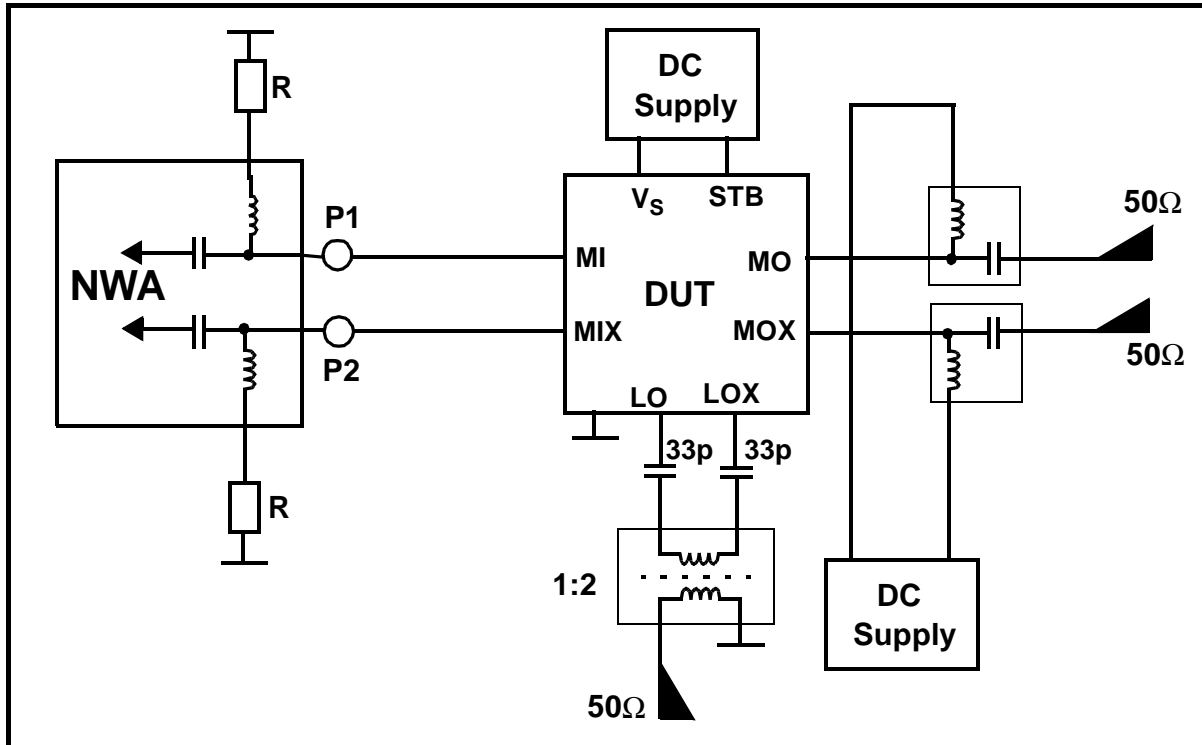

Mixer Input Impedance Measurement

Test Circuit 4b

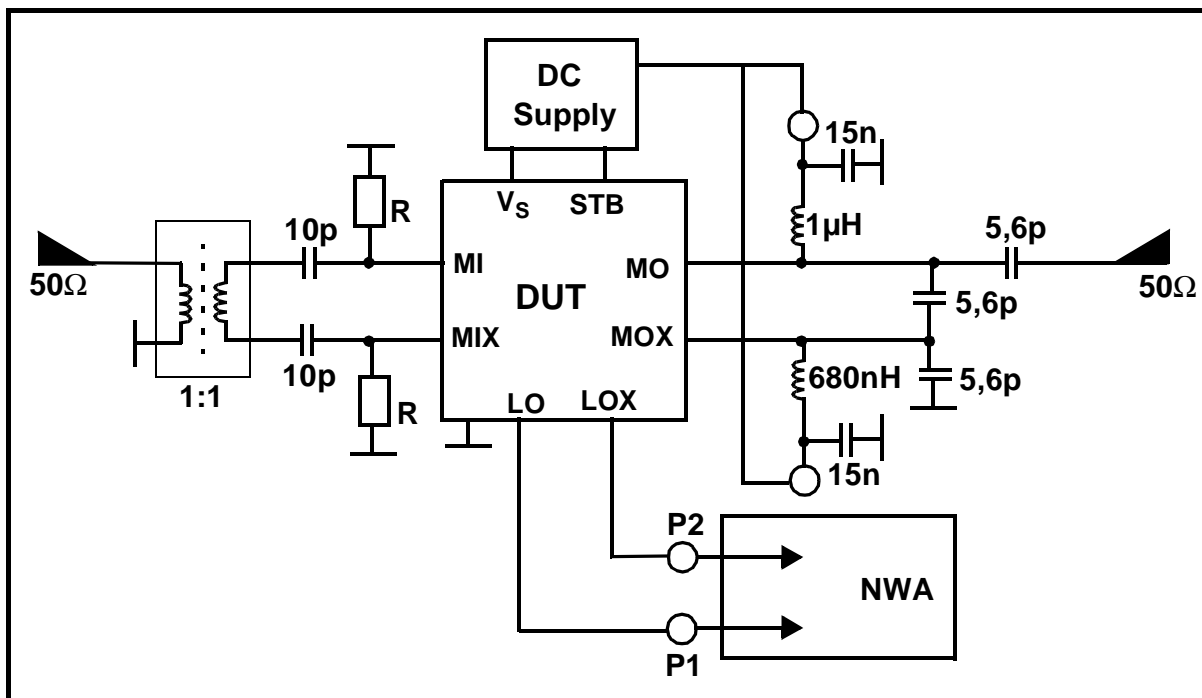

Mixer Local Oscillator Impedance Measurement

Test Circuit 4c

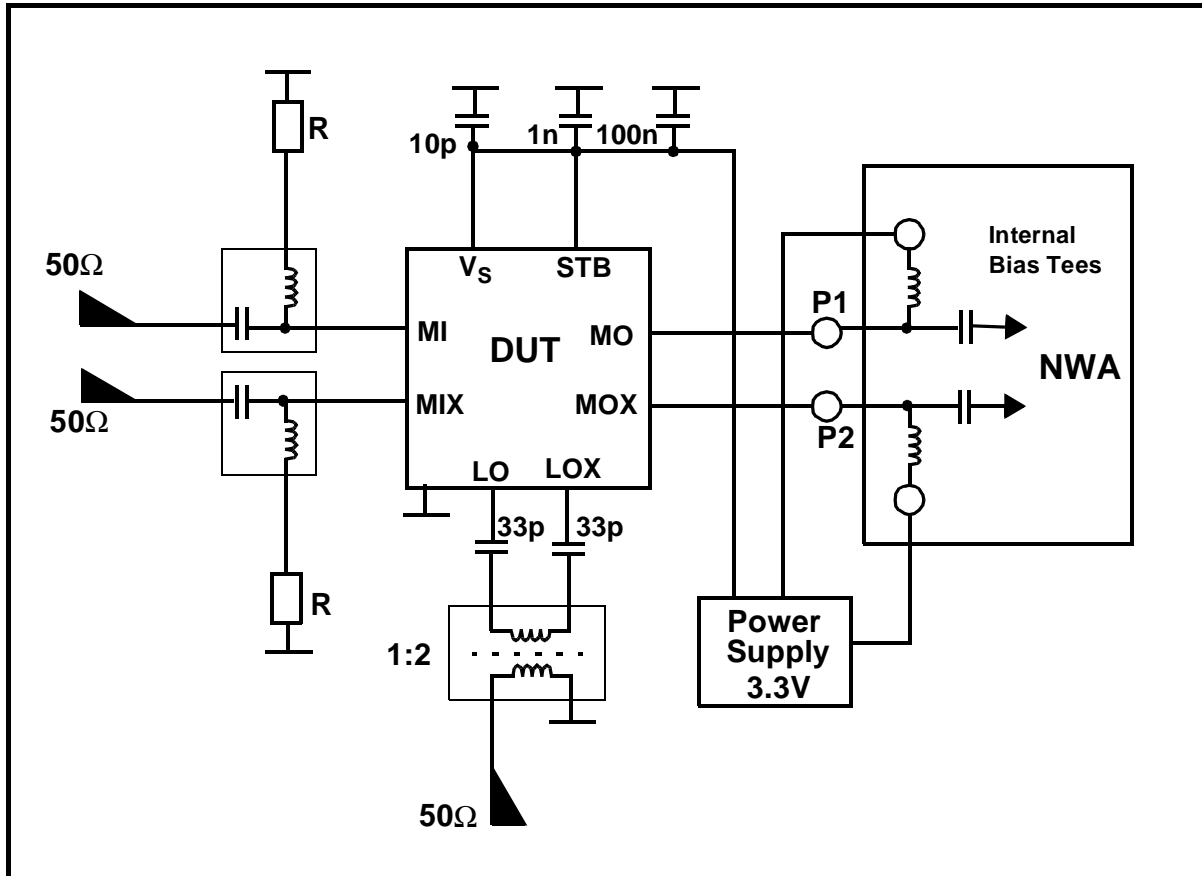

Mixer Output Impedance Measurement

Diagram 4a
Mixer MI Input Impedance Z_{MI} , $I_{MO/MOX} = 10\text{mA}$, $f=30\text{-}3000\text{MHz}$

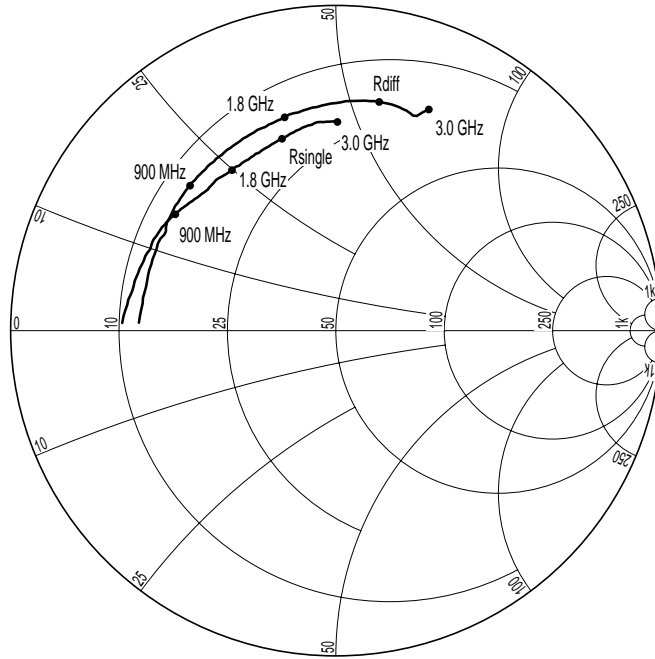

Diagram 4b
Mixer MI Input Impedance Z_{MI} , $I_{MO/MOX} = 4\text{mA}$, $f=30\text{-}3000\text{MHz}$

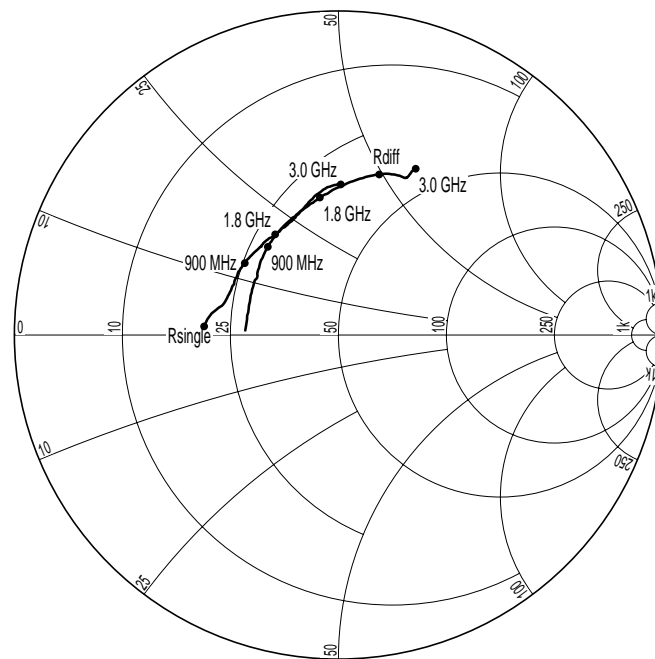

Diagram 4c
Mixer LO Input Impedance Z_{LO} , $I_{MO/MOX} = 10\text{mA}$, $f=30\text{-}3000\text{MHz}$

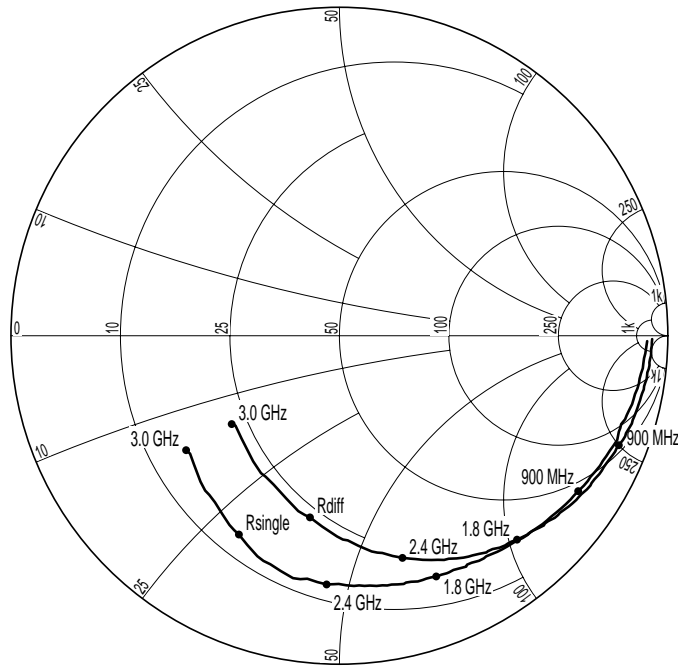

Diagram 4d
Mixer LO Input Impedance Z_{LO} , $I_{MO/MOX} = 4\text{mA}$, $f=30\text{-}3000\text{MHz}$

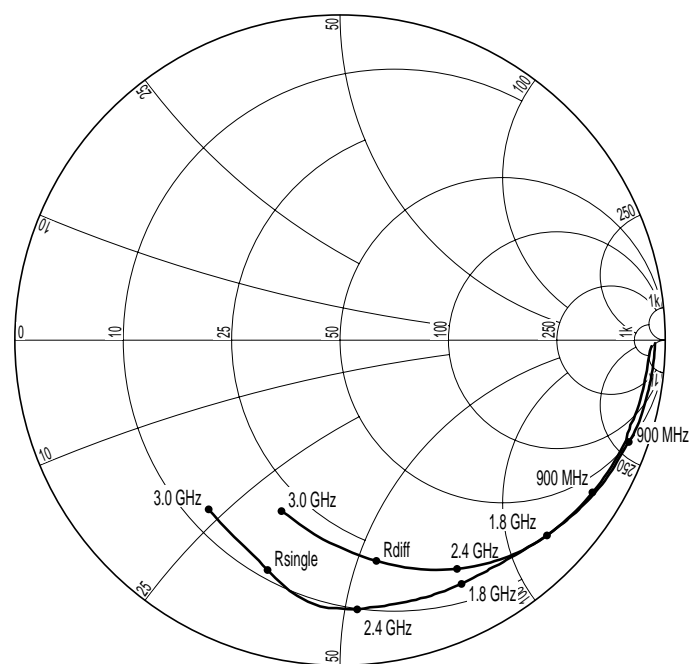
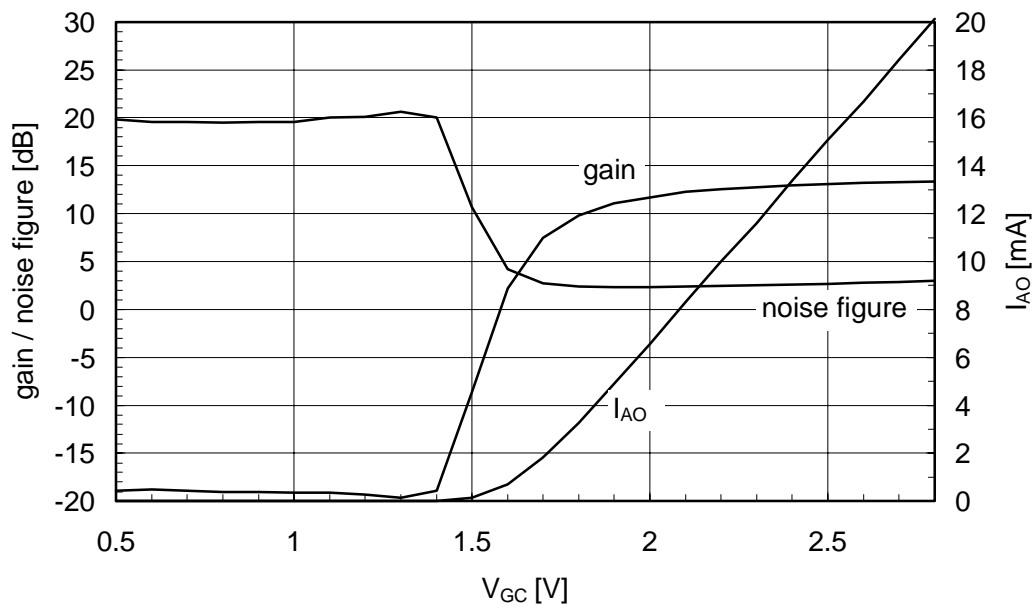

Diagram 5



Gain, Noise Figure and I_{AO} versus Gain Control voltage

Noise Figure values without correction of attenuation (0.4 dB) at input of the amplifier -> $NF_{min}=1.7dB$ at $V_{GC}=1.91V$, amplifier current $I_{AO}=5mA$, open collector voltage $V_{AO}=3.3V$ (according test circuit 2, $f=1.8GHz$).

3 Application Data

3.1 Receiver Application

3.1.1 Shortform Data

Measurement conditions

Ambient temperature $T_A = 25\text{ °C}$

Supply voltage $V_S = 2.7\text{ V}$

LNA and Mixer input signal $f_{RF} = 1960\text{ MHz}$, $P_{RF} = -30\text{ dBm}$

LO signal $f_{LO} = 1735\text{ MHz}$, $P_{LO} = -6\text{ dBm}$

IF output $f_{IF} = 225\text{ MHz}$

All measurements refer to SMA connectors without consideration of PCB losses

Parameter	Symbol	Limit values			Unit	Remarks
		min.	typ.	max.		
Mixer section						
Mixer current	I_{Mixer}		4		mA	$I_{MO}+I_{MOX}$
Conversion gain	G_C		8.5		dB	
Noise Figure (DSB)	NF_{DSB}		6.4		dB	
3rd order input intercept point	$IICP3$		+1		dBm	
1dB-compression point	P_{1dB}		-8		dBm	
Input blocking level	P_{BL}		-7		dBm	$\Delta f = 800\text{ kHz}$, -3dB for wanted signal
Port matching						
RF return loss	$ S_{11,RF} $		12		dB	
LO return loss	$ S_{11,LO} $		10		dB	
IF return loss	$ S_{11,IF} $		11		dB	
Isolations						
LO to IF output	A_{LO-IF}		40		dB	$f = 1735\text{ MHz}$

Measurement conditions

Ambient temperature $T_A = 25\text{ °C}$

Supply voltage $V_S = 2.7\text{ V}$

LNA and Mixer input signal $f_{RF} = 1960\text{ MHz}$, $P_{RF} = -30\text{ dBm}$

LO signal $f_{LO} = 1735\text{ MHz}$, $P_{LO} = -6\text{ dBm}$

IF output $f_{IF} = 225\text{ MHz}$

All measurements refer to SMA connectors without consideration of PCB losses

Parameter	Symbol	Limit values			Unit	Remarks
		min.	typ.	max.		
LO to RF input	A_{LO-RF}		43 25 35		dB dB dB	$f_{LO} = 1735\text{ MHz}$ $f_{image,min} = 1480\text{ MHz}$ $f_{signal,max} = 1990\text{ MHz}$
RF input to LO	A_{RF-LO}		48		dB	$f = 1960\text{ MHz}$
LNA section						
LNA current	I_{LNA}		4.6		mA	
Gain	G		12.5		dB	
Noise Figure	NF		1.8		dB	assuming a PCB loss of 0.25 dB at AI, typical noise figure at matching circuit results to 1.55 dB
3rd order input intercept point	IICP3		0		dBm	
1dB-compression point	P_{1dB}		-10		dBm	
AI return loss	$ S_{11,AI} $		11		dB	
AO return loss	$ S_{11,AO} $		14		dB	

3.1.2 Measurement results

Mixer section

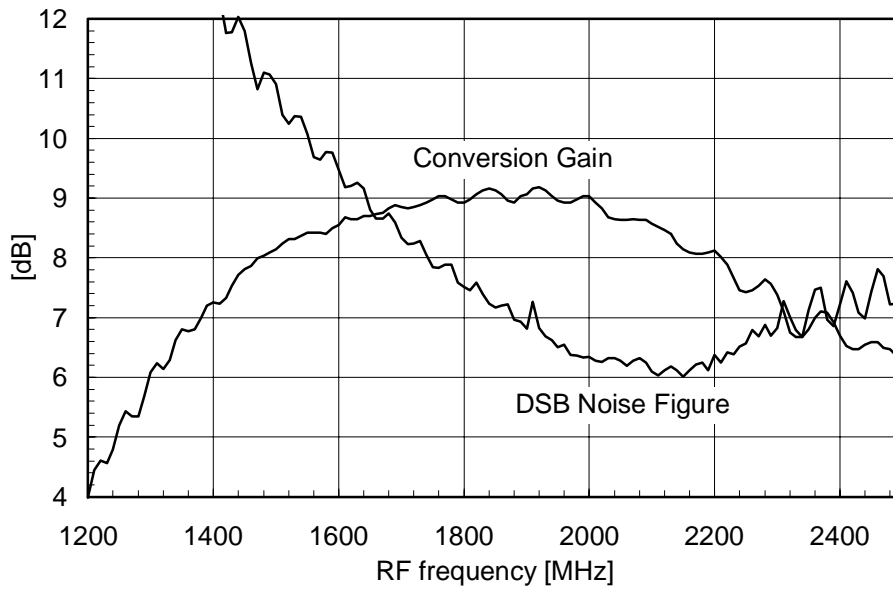

Figure 1: Conversion Gain an Noise Figure versus Frequency

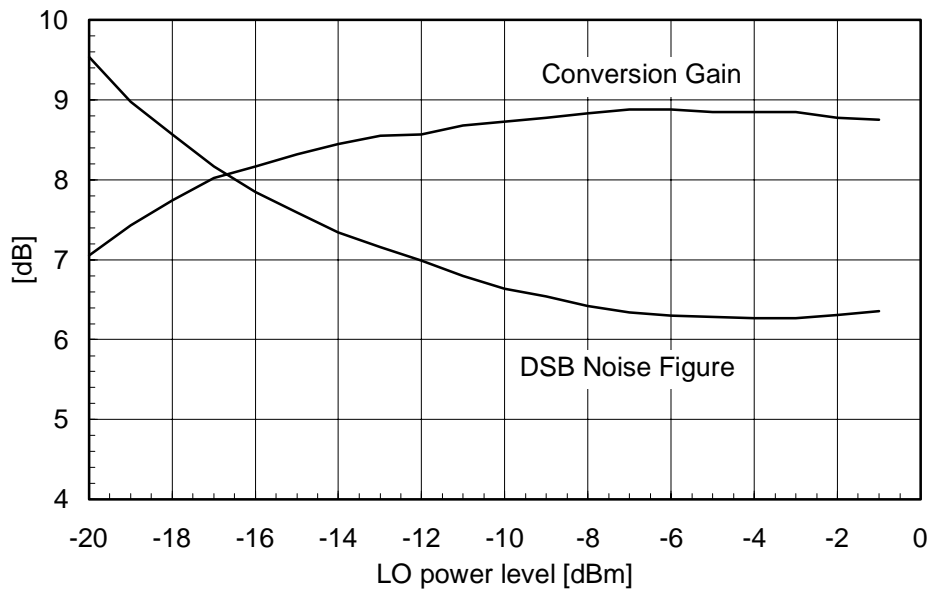

Figure 2: Conversion Gain and Noise Figure versus LO power

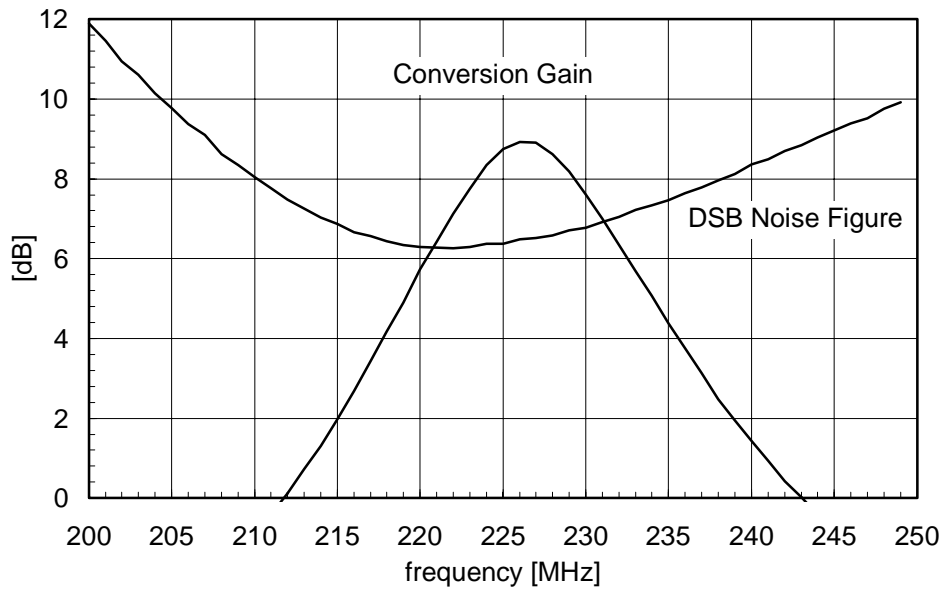

Figure 3: Conversion Gain and Noise Figure versus IF frequency

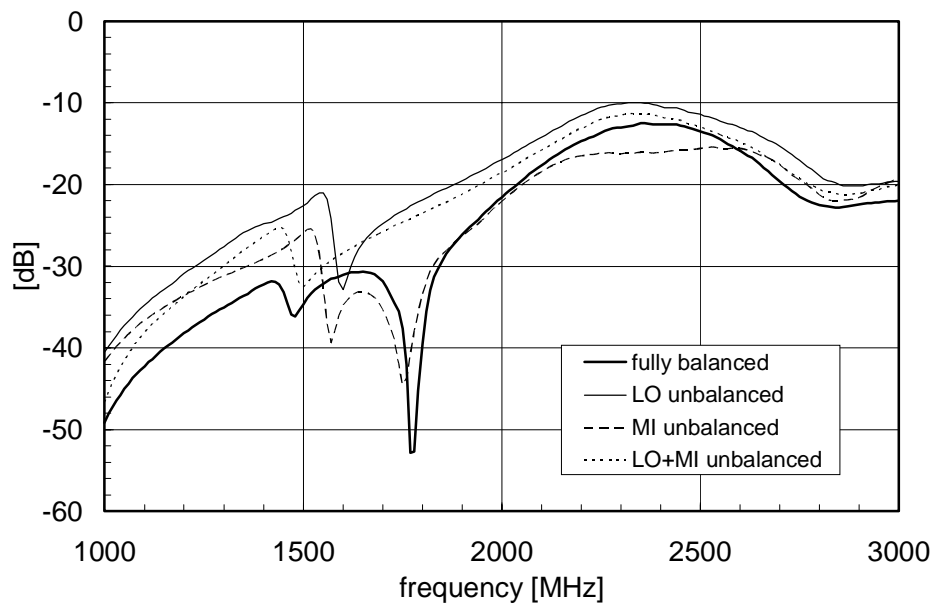

Figure 4: Isolation LO to IF

In unbalanced case the matching network is replaced by a 10pF series capacitor to one port pin. The other port pin is tied to ground via a second 10pF capacitor. This means **no** power matching is done.

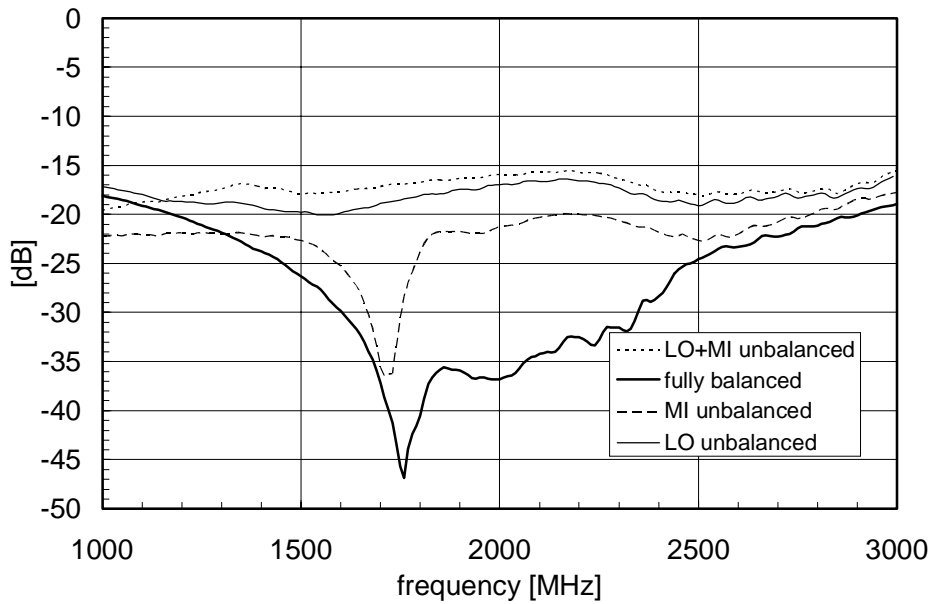

Figure 5: Isolation LO to RF

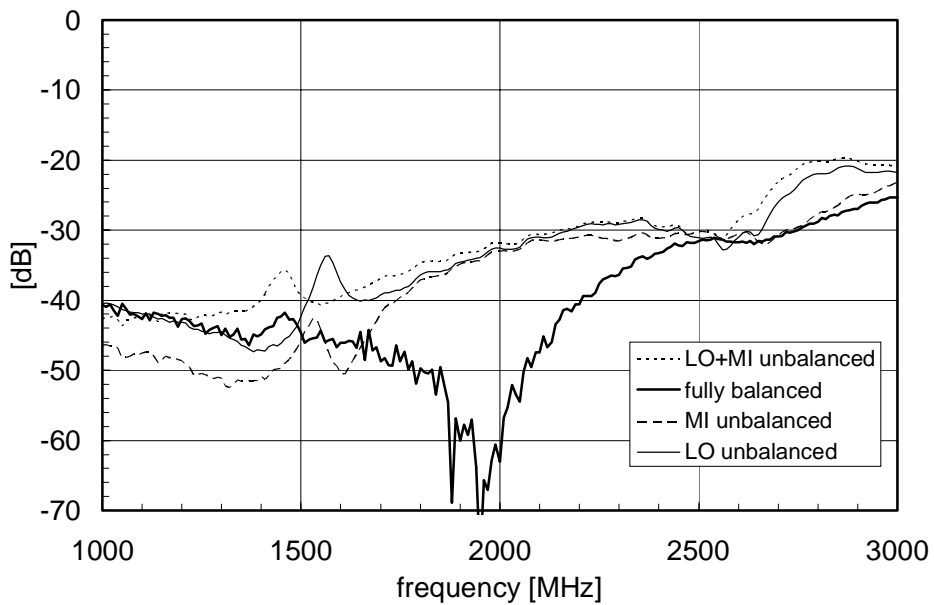

Figure 6: Isolation RF to LO

LNA section

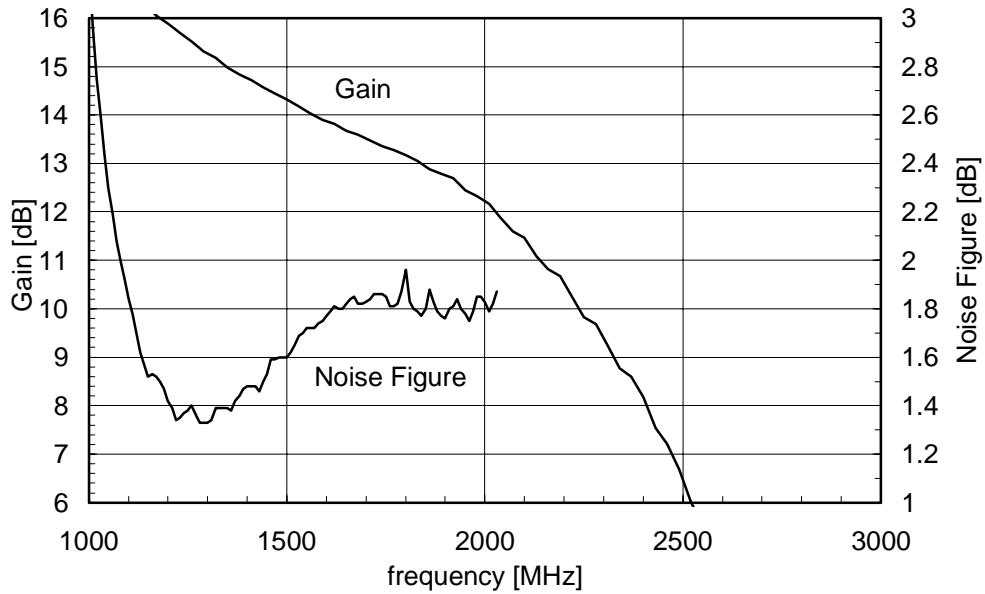

Figure 7: Gain and noise figure versus frequency

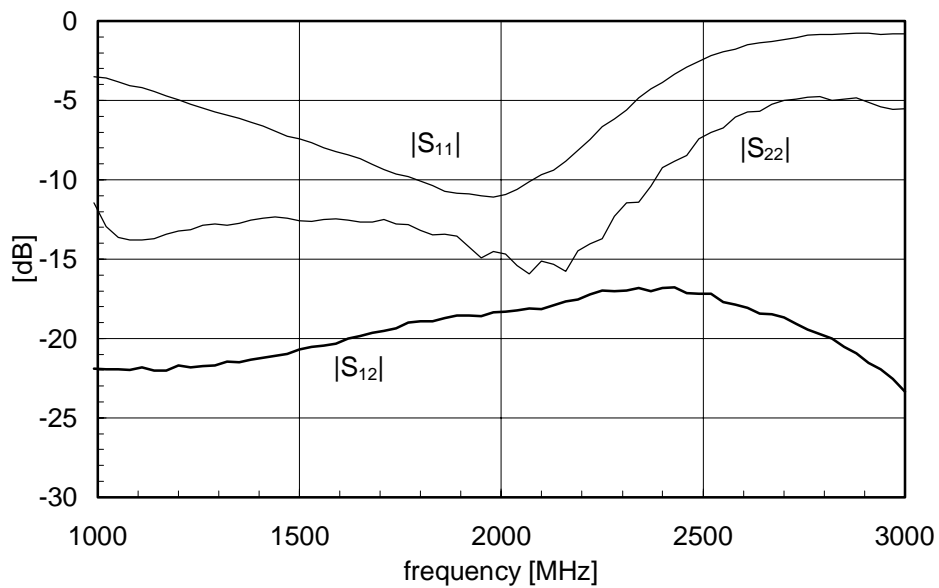

Figure 8: Reverse isolation and return loss versus frequency

3.1.3 Application hint - Mixer metrics versus mixer current

Mixer current may be increased to obtain a higher Input 3rd Order Intercept (IIP3), higher 1 dB Compression Point (P1dB), and increased Conversion Gain (G). In a typical application, in order to increase mixer current from the minimum level of 800µA, R5 and R6 are added as shown in the circuit diagram at the end of this section. These external resistors are placed in parallel to existing bias resistors internal to the PMB2333, thereby reducing the aggregate resistance in the emitters and increasing current. As current is increased by further reduction of the value of R5 and R6, the mixer inputs MI and MIX may begin to suffer ‘RF Loading’ unless RF chokes are used between the MI/MIX pins and R5 / R6 (compare test circuit 1).

For the data presented in this section, mixer current was varied in a different manner. To eliminate the effects of RF impedance variation (due to ‘RF Loading’) at MI / MIX caused by changing the values of R5 and R6 for different mixer currents, these resistors were set equal to 1kΩ. Mixer current was then varied by adjusting the power supply voltage Vx. Note that Vx may take on positive values with respect to ground for low (e.g. 1mA) mixer currents, or negative values for higher currents.

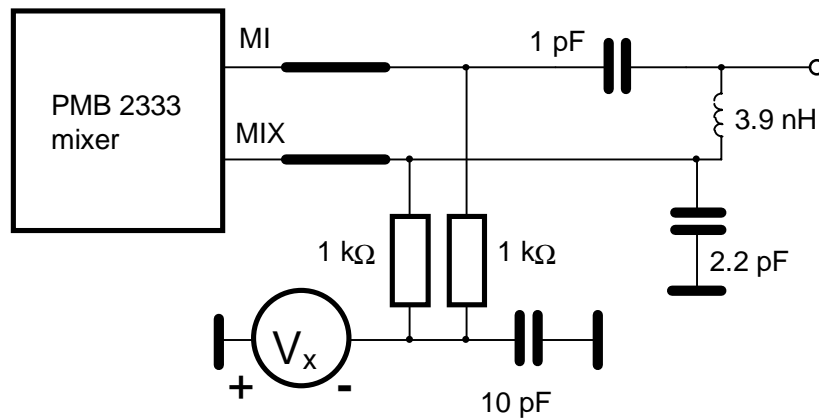

Figure 9: Modified mixer input circuitry

Note that the mixer input impedance seen at MI / MIX is a strong function of mixer current. The mixer input balanced-to-unbalanced transformer/matching circuitry was originally tuned for a current of 4mA, and was **not** re-optimized for each of the other current levels. Despite this limitation, the return loss at the 50Ω port is better than 10dB over the entire 1 to 10 mA current range. The mixer output (MO / MOX) and local oscillator (LO / LOX) ports exhibit negligible change in impedance over this same current range.

Measurement conditions: $T_A = 25\text{ °C}$
 $V_{CC} = 2.7\text{ V and } 4.5\text{V}$
 $f_{RF} = 1960\text{ MHz}$
 $f_{LO} = 1735\text{ MHz, } P_{LO} = -6\text{ dBm}$

The Effect of Power Supply Voltage on Mixer Metrics

In seeking to improve Mixer Input Third-Order Intercept and 1dB Compression Point, it is important to understand the constraints on these parameters imposed by power supply voltage. **Refer to Figure 10.**

Receiver 'Blocking' is predominantly influenced by the Mixer's 1 dB Compression Point (P1dB) and **not** the Input 3rd Order Intercept Point (IIP3). For a supply voltage of 4.5V, mixer P1dB (referred to the input of the application circuitry) increases with additional mixer current, and begins to flatten out above 8mA. When supply voltage is decreased to 2.7V, mixer P1dB starts flattening out at around 5mA.

Note how, at the 2.7V supply voltage, IIP3 continues to increase at currents over 6mA while P1dB flattens out. For a given conversion gain G, while operating at 2.7 Volts, considering only the mixer's Input 3rd Order Intercept (IIP3) might lead one to falsely conclude that increasing current beyond 6mA improves receiver blocking. If, however, conversion gain is decreased, it may be possible to improve the receiver's blocking level with additional mixer current.

As shown in Figure 10, the 1 dB compression level, referred to the input, is limited by either current or the available voltage swing at the mixer output. The transition between these two regions takes place at 4mA for the specified conversion gain and supply voltage.

Figure 11 gives the DSB mixer noise figure versus the mixer current.

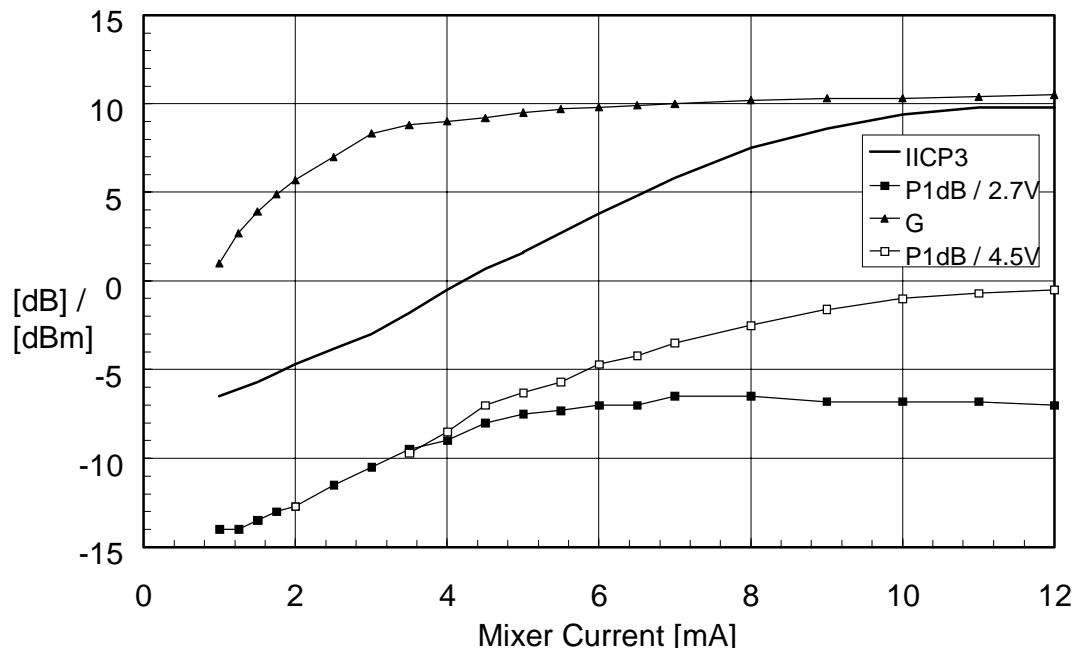

Figure 10: Mixer Input Intercept Point (IIP3), 1 dB Compression Point (P1dB) Referred to Input, Gain (G).

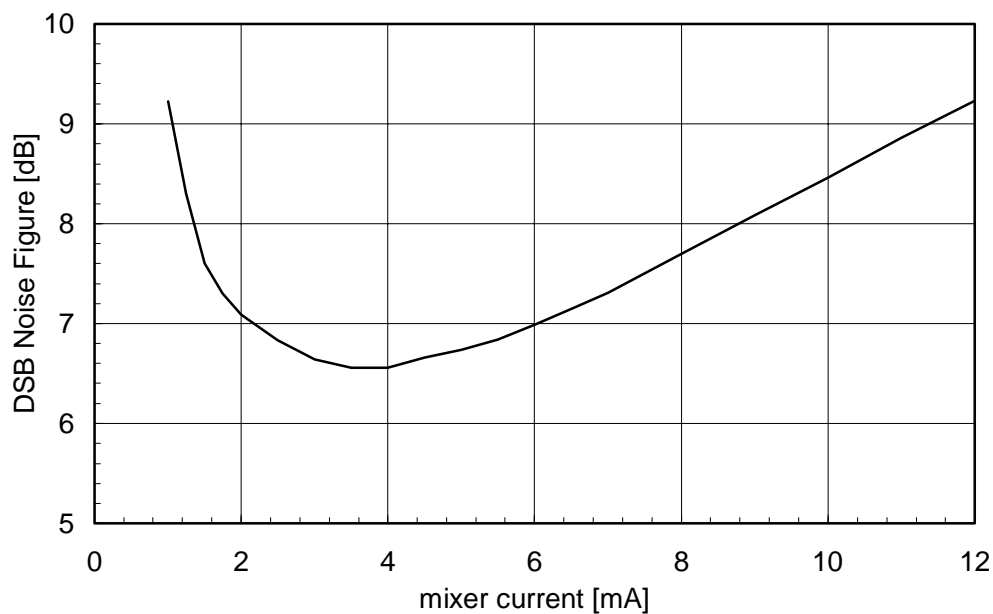

Figure 11: Mixer DSB Noise Figure

3.1.4 Circuit diagram and PCB layout

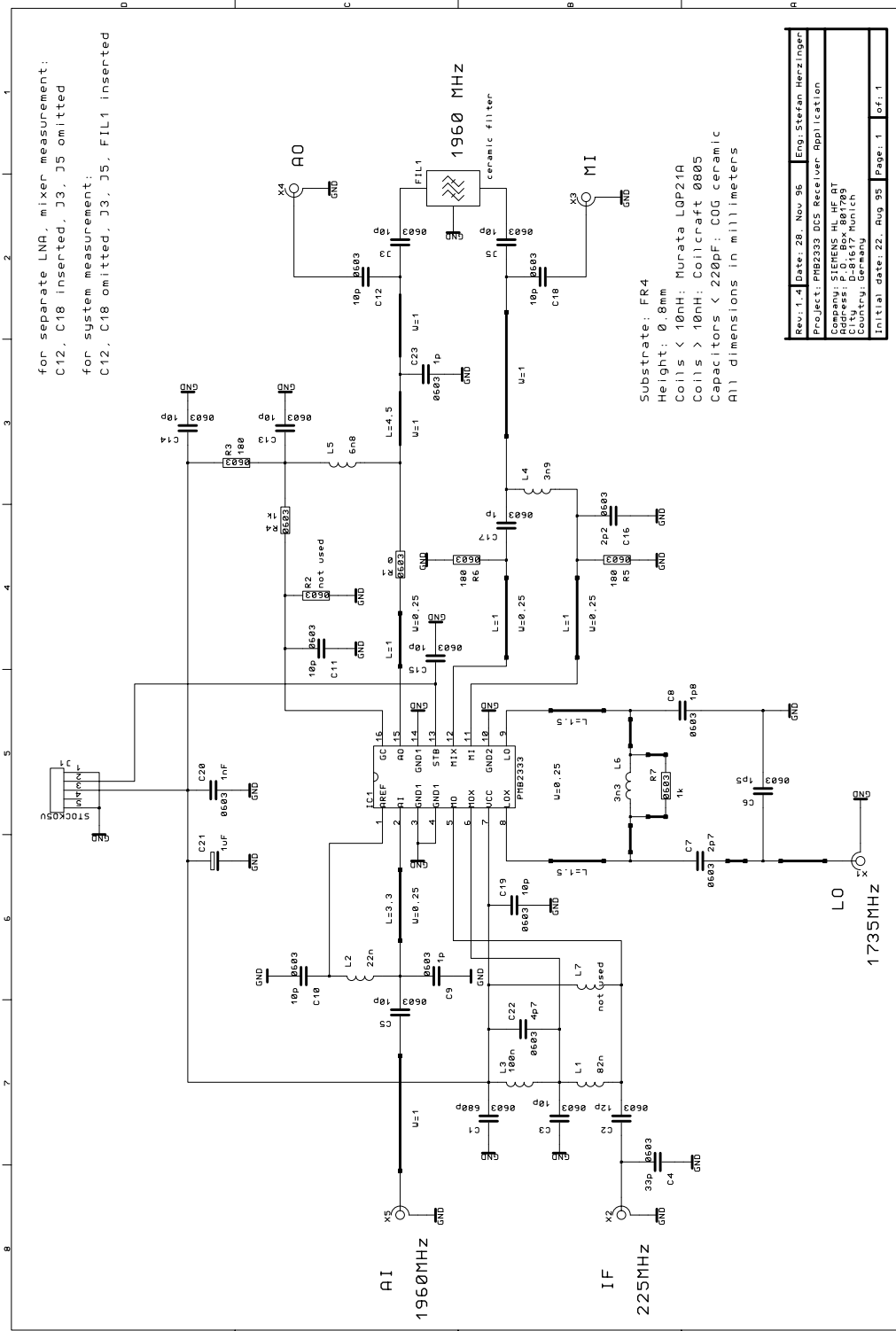

Figure 12: Circuit diagram

PCB dimensions: 80 x 50 mm

Substrate material: FR4

Substrate height: 0.8 mm

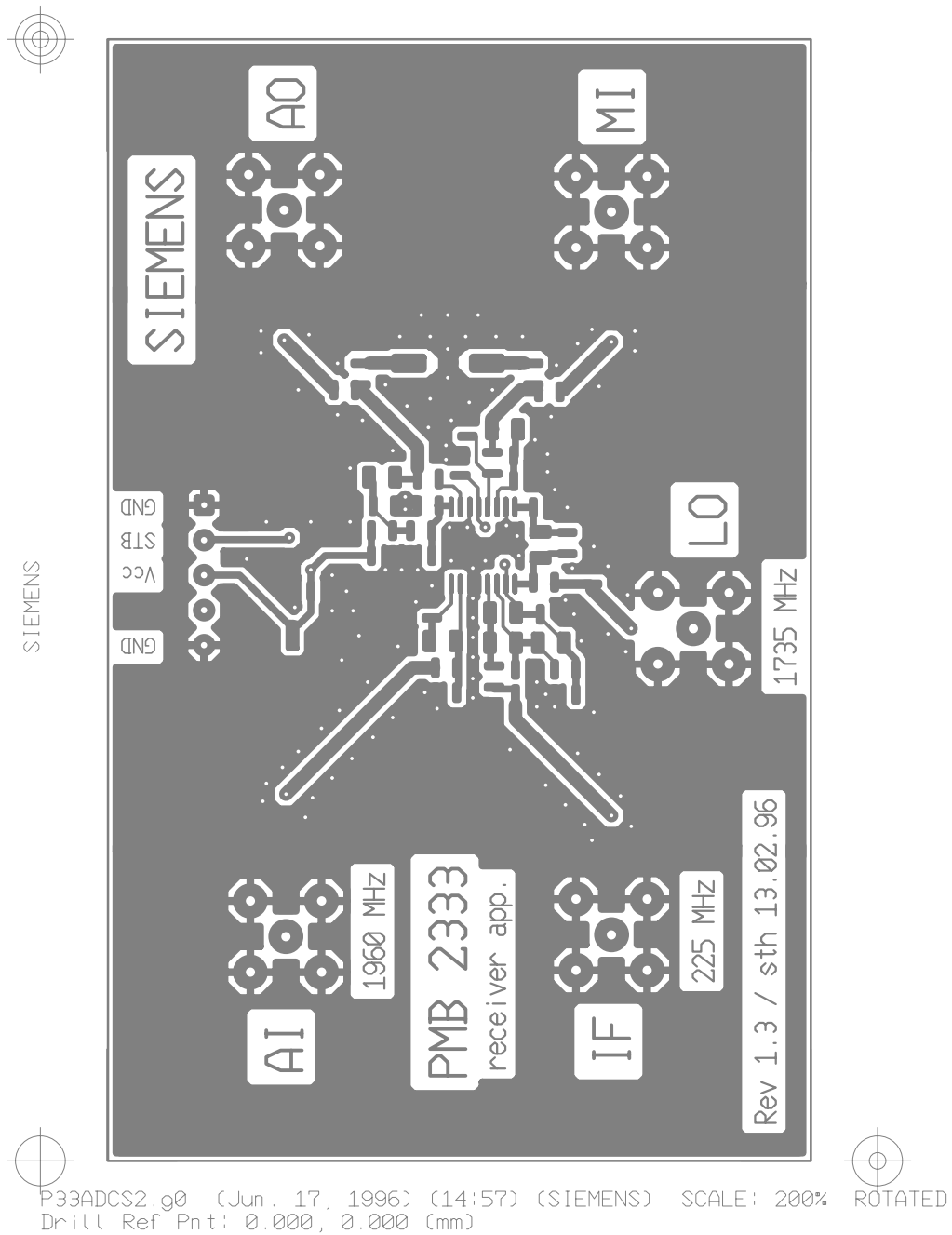

Figure 13: PCB top side

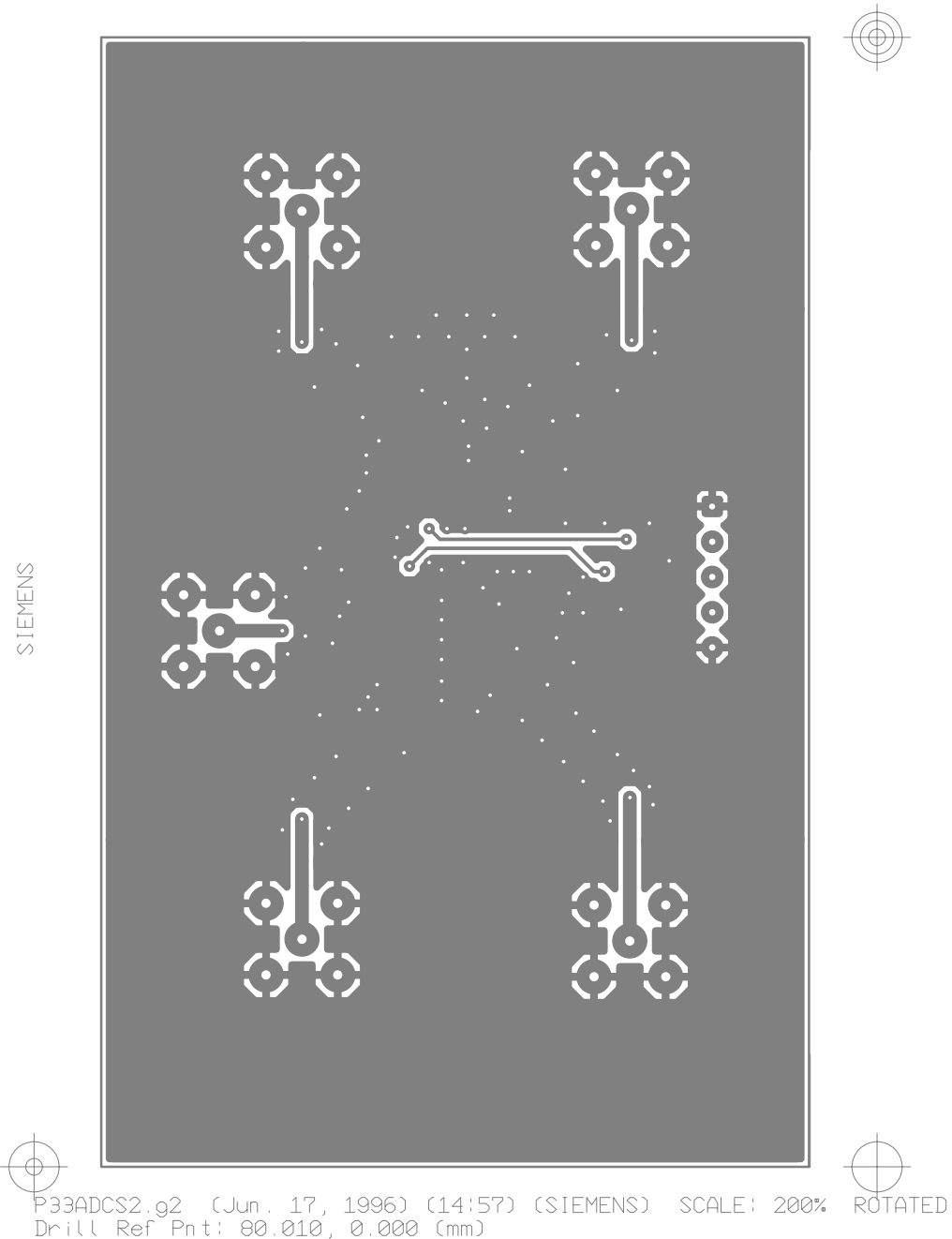

Figure 14: PCB bottom side

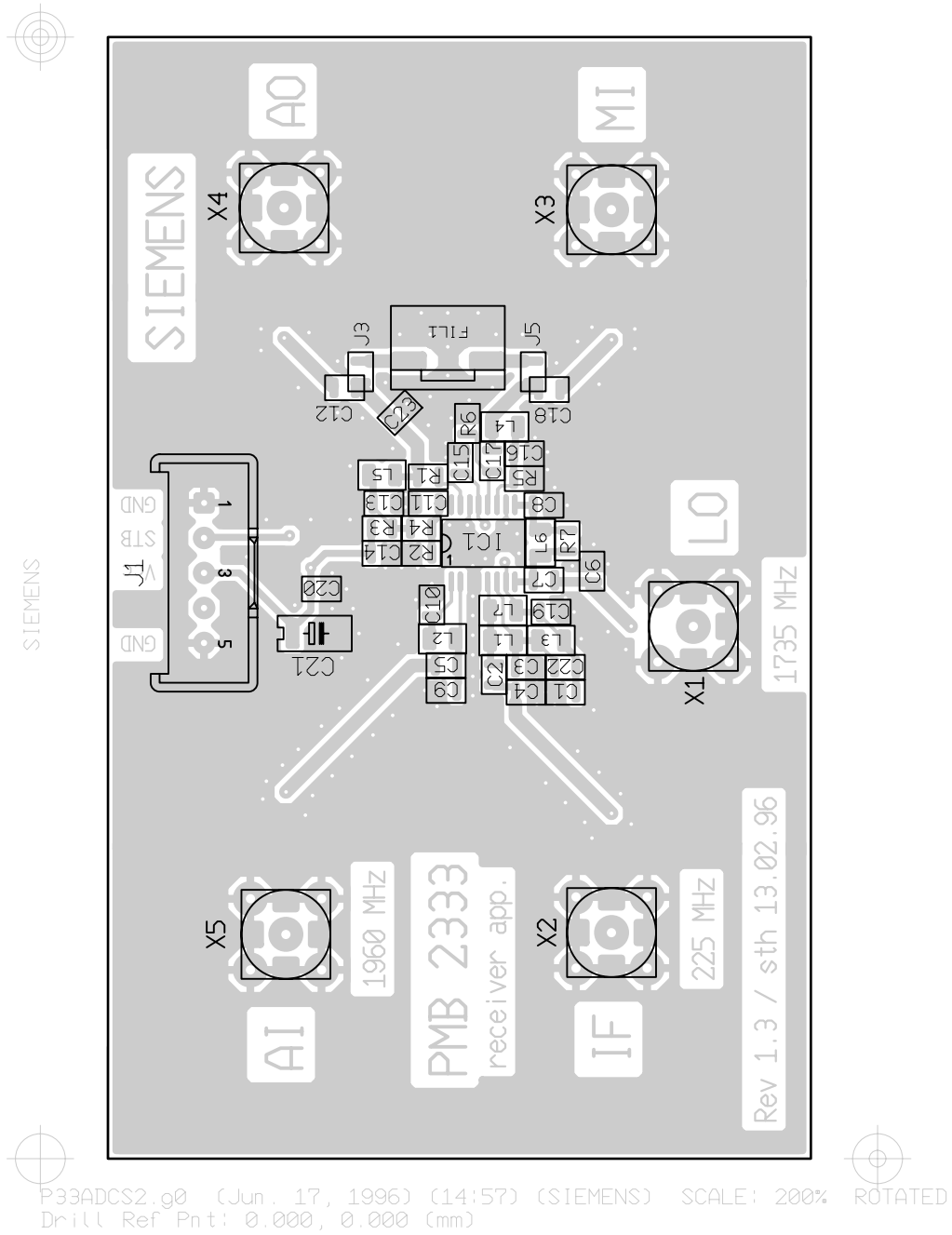

Figure 15: PCB component placement

List of Components

Item	Quantity	Reference	Value	Part	
1	3	C9, C17, C23	1.0 pF	SMD/0603	
2	1	C6	1.5 pF	SMD/0603	
3	1	C8	1.8 pF	SMD/0603	
4	1	C16	2.2 pF	SMD/0603	
5	1	C7	2.7 pF	SMD/0603	
6	1	C22	4.7 pF	SMD/0603	
7	10	C3, C5, C10, C11, C12, C13, C14, C15, C18, C19	10 pF	SMD/0603	
8	1	C2	12 pF	SMD/0603	
9	1	C4	33 pF	SMD/0603	
10	1	C1	680 pF	SMD/0603	
11	1	C20	1.0 nF	SMD/0603	
12	1	C21	1 μ F	SMD/A	Tantalum
13	1	R1	0 Ω	SMD/0603	
14	3	R3, R5, R6	180 Ω	SMD/0603	
15	2	R4, R7	1.0 k Ω	SMD/0603	
16	1	L6	3.3 nH	SMD/0805	Murata LQP21A or LQP11A
17	1	L4	3.9 nH	SMD/0805	Murata LQP21A or LQP11A
18	1	L5	6.8 nH	SMD/0805	Murata LQP21A or LQP11A
19	1	L2	22 nH	SMD/0805	Coilcraft 0805
20	1	L1	82 nH	SMD/0805	Coilcraft 0805
21	1	L3	100 nH	SMD/0805	Coilcraft 0805
22	1	IC1	PMB 2333	Siemens	
23	1	J1	connector	Stocko MKS 1655-6-0-505	
24	5	X1, X2, X3, X4, X5	SMA connector	Suhner 82 SMA 50-0-41 or Rosenberger 32 K 141-400A2	

3.2 Upconversion Application

3.2.1 Shortform Data

Measurement conditions

Ambient temperature $T_A = 25\text{ °C}$

Supply voltage $V_S = 2.7\text{ V}$

Mixer input signal $f_{IF} = 190\text{ MHz}$, $P_{IF} = -30\text{ dBm}$

LO signal $f_{LO} = 1717\text{ MHz}$, $P_{LO} = -6\text{ dBm}$

Mixer output and driver amplifier input signal $f_{RF} = 1907\text{ MHz}$

Parameter	Symbol	Limit values			Unit	Remarks
		min.	typ.	max.		
Mixer section						
Mixer current	I_{Mixer}		9.5		mA	
Conversion gain	G_C		6		dB	
3rd order input intercept point	IICP3		+3.5		dBm	
1dB-compression point	P_{1dB}		-7		dBm	
Port matching						
RF return loss	$ S_{11,RF} $		10		dB	
LO return loss	$ S_{11,LO} $		18		dB	
IF return loss	$ S_{11,IF} $		20		dB	
Isolations						
RF to LO input	A_{RF-LO}		38		dB	
LO to RF output	A_{LO-RF}		30		dB	
Driver section						
Driver current	I_{AO}		11.0		mA	17mA @ 3.3V
Gain	G		13.1		dB	
3rd order input intercept point	IICP3		+4.5		dBm	
1dB-compression point	P_{1dB}		-6		dBm	

Measurement conditions

Ambient temperature $T_A = 25\text{ °C}$

Supply voltage $V_S = 2.7\text{ V}$

Mixer input signal $f_{IF} = 190\text{ MHz}$, $P_{IF} = -30\text{ dBm}$

LO signal $f_{LO} = 1717\text{ MHz}$, $P_{LO} = -6\text{ dBm}$

Mixer output and driver amplifier input signal $f_{RF} = 1907\text{ MHz}$

Parameter	Symbol	Limit values			Unit	Remarks
		min.	typ.	max.		
AI return loss	$ S_{11,AI} $		14		dB	
AO return loss	$ S_{11,AO} $		12		dB	

3.2.2 Measurement results

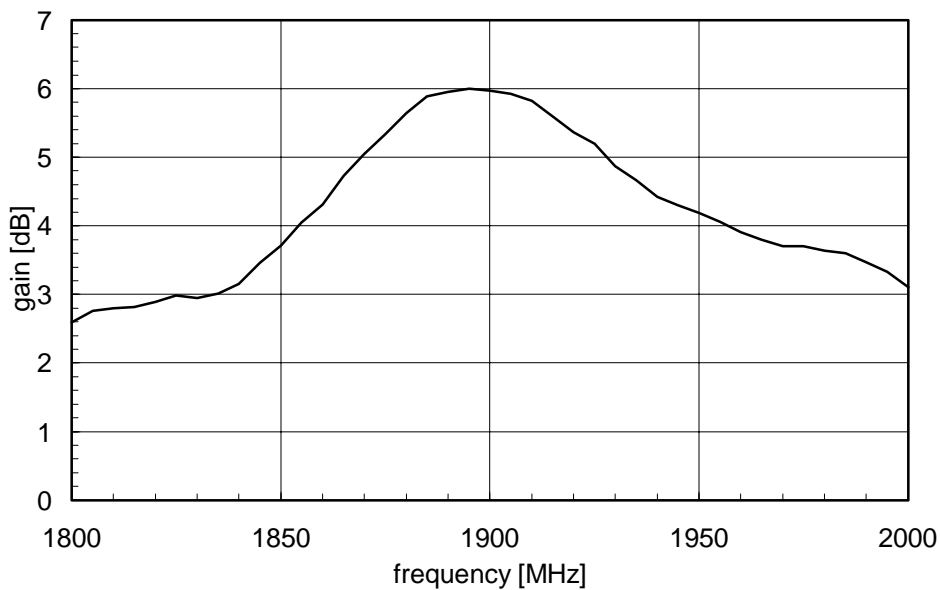

Figure 16: Mixer conversion gain versus frequency

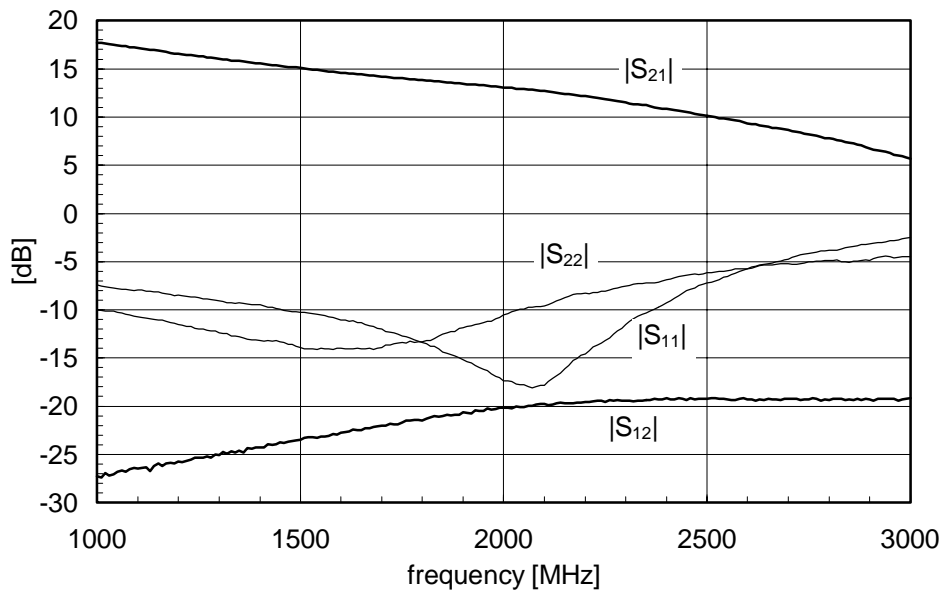

Figure 17: Driver amplifier gain, reverse isolation, return loss versus frequency

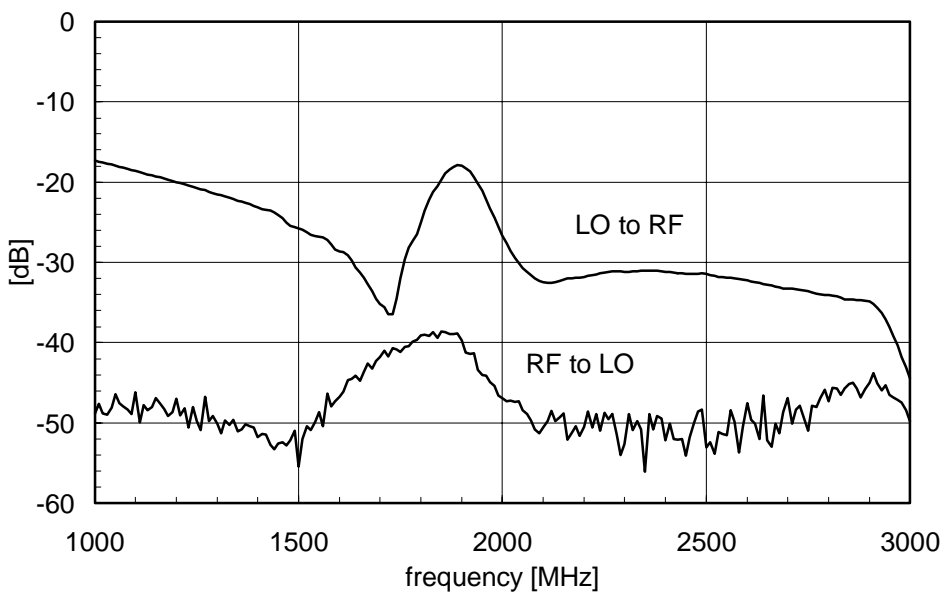

Figure 18: Mixer isolations versus frequency

3.2.3 Circuit diagram and PCB layout

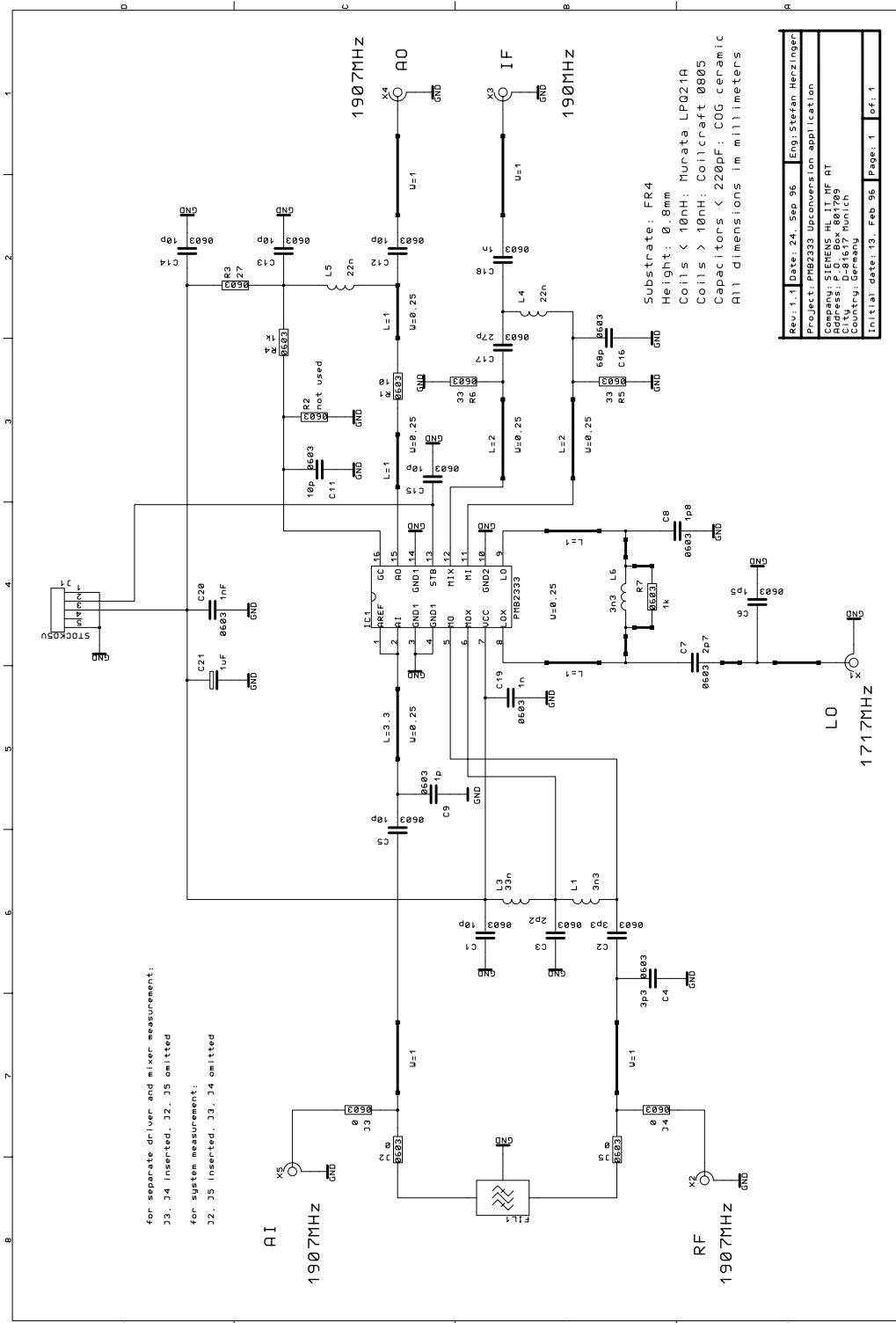

Figure 19: Circuit diagram

PCB dimensions: 80 x 50 mm

Substrate material: FR4

Substrate height: 0.8 mm

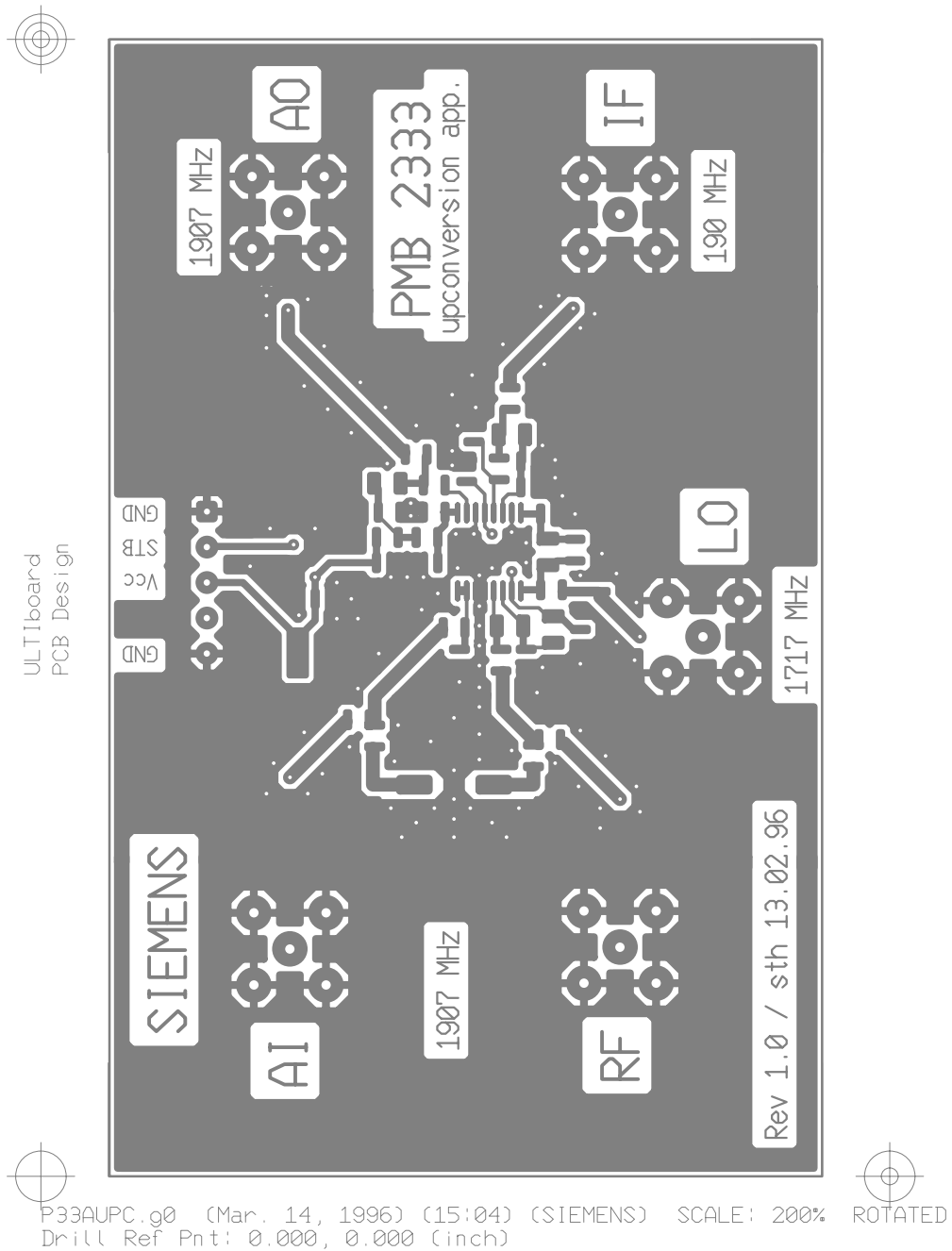

Figure 20: PCB top side

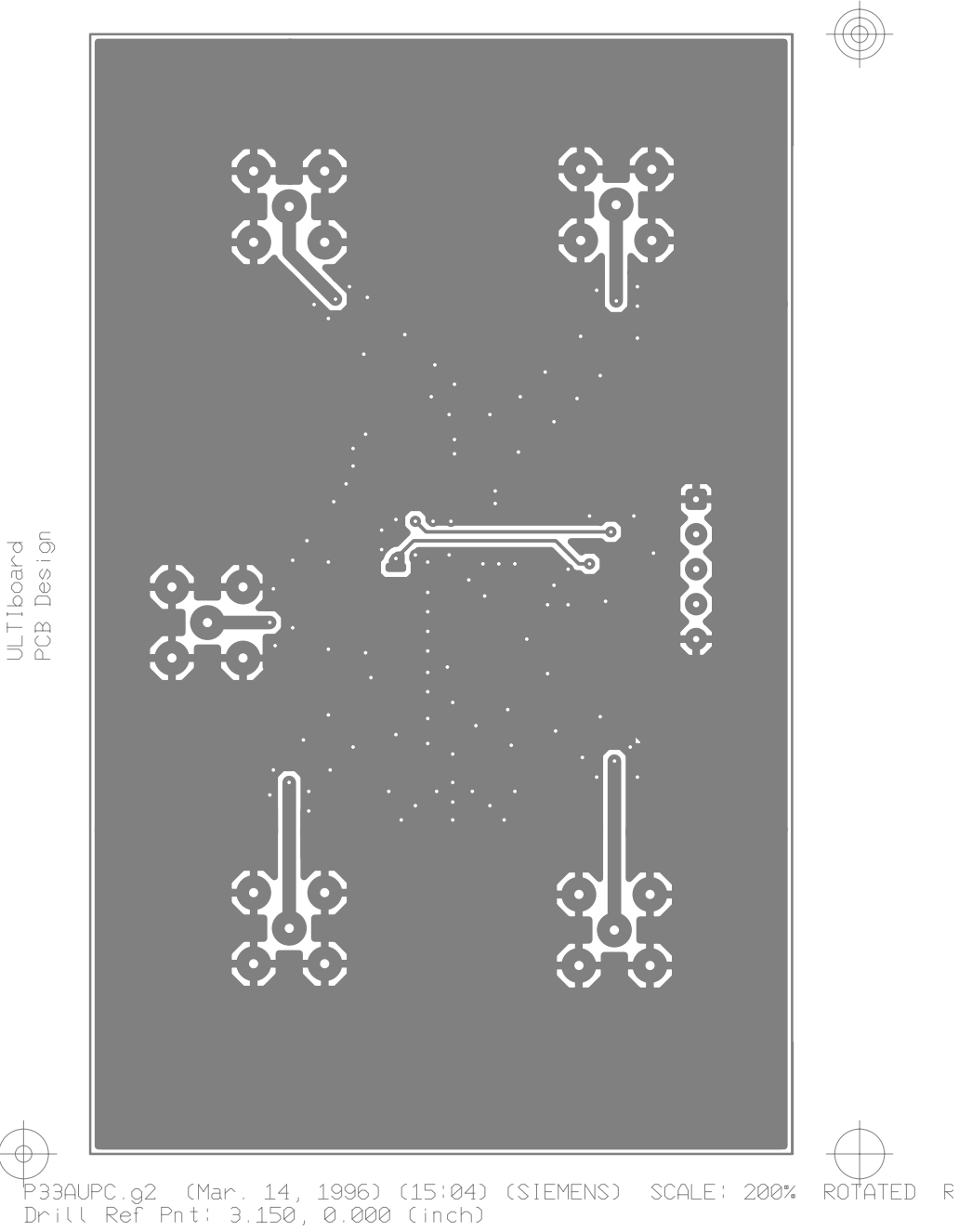

Figure 21: PCB bottom side

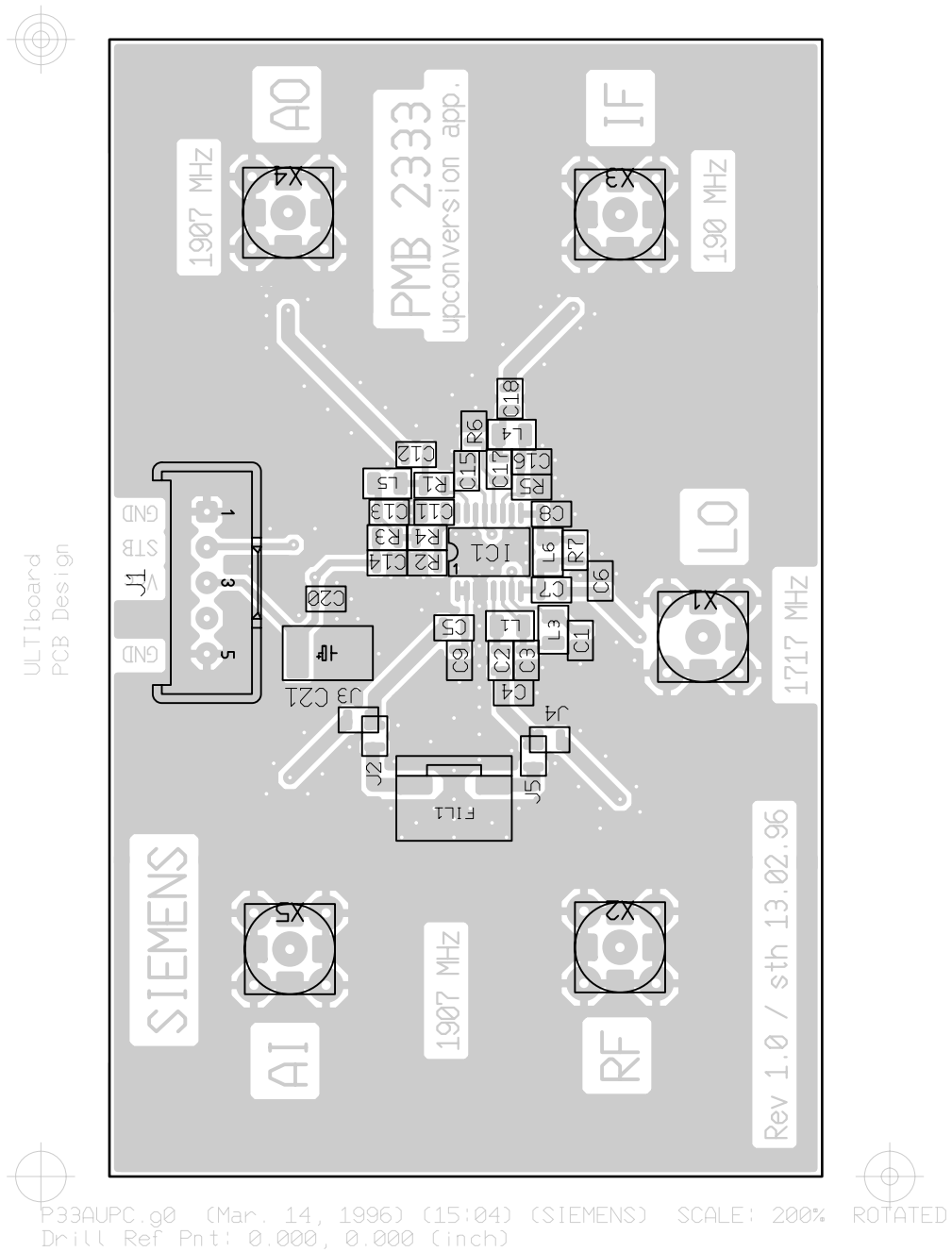

Figure 22: Component placement top side

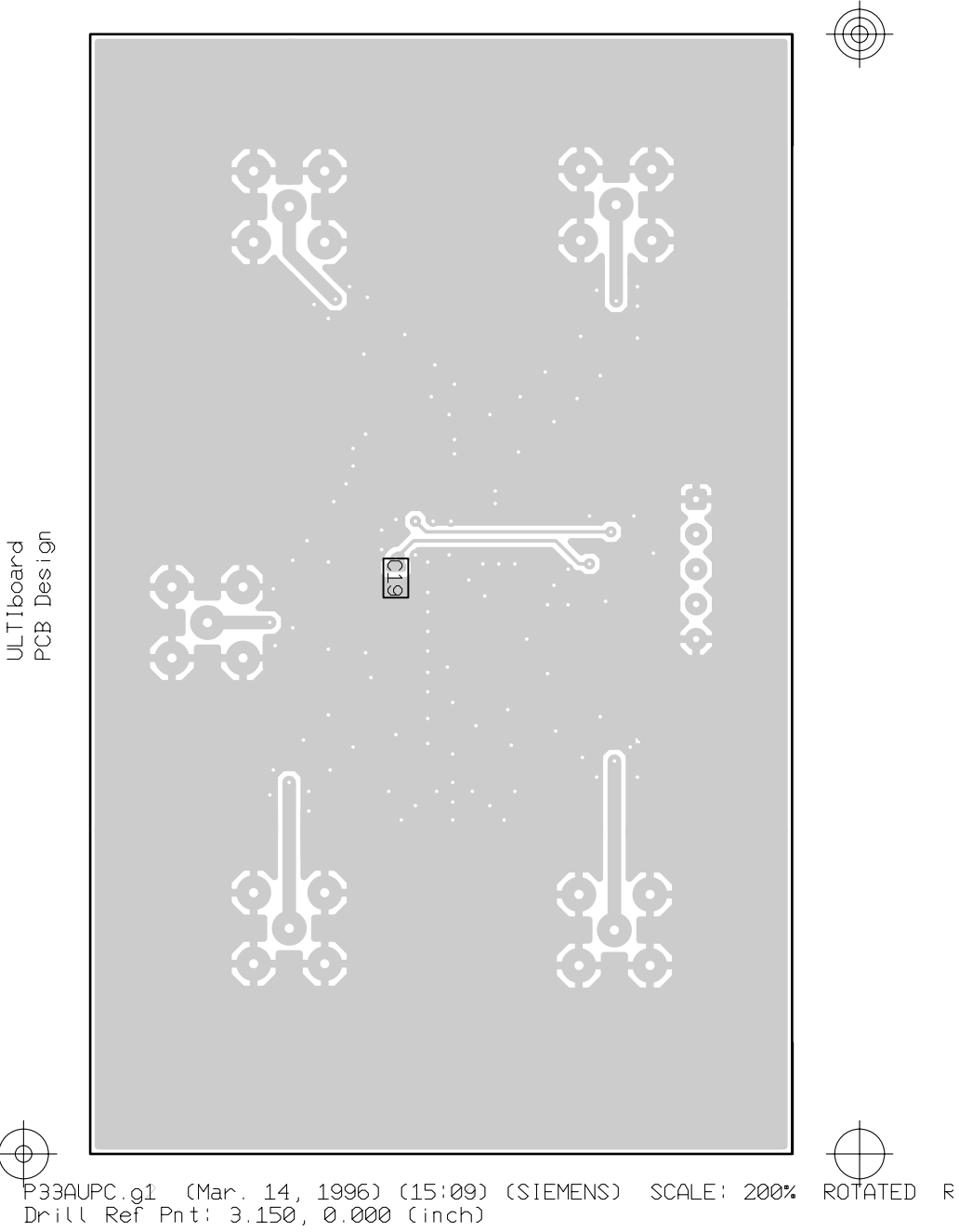

Figure 23: Component placement bottom side

Upconversion Application - List of Components

Item	Quantity	Reference	Value	Part	
1	1	C9	1.0 pF	SMD/0603	
2	1	C6	1.5 pF	SMD/0603	
3	1	C8	1.8 pF	SMD/0603	
4	1	C3	2.2 pF	SMD/0603	
5	1	C7	2.7 pF	SMD/0603	
6	2	C2, C4	3.3 pF	SMD/0603	
7	7	C1, C5, C11, C12, C13, C14, C15	10 pF	SMD/0603	
8	1	C17	27 pF	SMD/0603	
9	1	C16	68 pF	SMD/0603	
10	3	C18, C19, C20	1.0 nF	SMD/0603	
11	1	C21	1.0 μ F	SMD/A	Tantalum
12	2	J3, J4	0 Ω	SMD/0603	
13	1	R1	10 Ω	SMD/0603	
14	1	R3	27 Ω	SMD/0603	
15	2	R5, R6	33 Ω	SMD/0603	
16	2	R4, R7	1 k Ω	SMD/0603	
17	2	L1, L6	3.3 nH	SMD/0603	Murata LQP11A
18	2	L4, L5	22 nH	SMD/0805	Coilcraft 0805
19	1	L3	33 nH	SMD/0805	Coilcraft 0805
20	1	IC1	PMB 2333	Siemens	
21	1	J1	connector	Stocko MKS 1655-6-0-505	
22	5	X1, X2, X3, X4, X5	SMA connector	Suhner 82 SMA 50-0-41 or Rosenberger 32 K 141-400A2	

3.3 Receiver/SAW Application

3.3.1 Shortform Data

Measurement conditions

Ambient temperature $T_A = 25\text{ °C}$

Supply voltage $V_S = 3.6\text{ V}$

LNA and Mixer input signal $f_{RF} = 890\text{ MHz}$, $P_{RF} = -40\text{ dBm}$

LO signal $f_{LO} = 972\text{ MHz}$, $P_{LO} = -6\text{ dBm}$

IF output $f_{IF} = 82\text{ MHz}$

All measurements refer to SMA connectors without consideration of PCB losses

The figures in the mixer section are calculated from a measurement SAW filter + mixer assuming an insertion loss of 3.1dB for the filter at measurement frequency (890MHz).

Parameter	Symbol	typ. Value	Unit	Remarks
Mixer section				
Mixer current	I_{Mixer}	10	mA	$I_{MO}+I_{MOX}$
Conversion gain	G_C	4.5	dB	
Noise Figure (SSB)	NF_{SSB}	12	dB	
3rd order input intercept point	$IICP3$	+6.5	dBm	
input 1dB-compression point	P_{1dB}	-3	dBm	
LNA section				
LNA current	I_{LNA}	17	mA	
Gain	G_{LNA}	20	dB	
Noise Figure	NF	1.75	dB	
3rd order input intercept point	$IICP3$	0	dBm	
input 1dB-compression point	P_{1dB}	-11	dBm	
AI return loss	$ S_{11, AI} $	14	dB	
AO return loss	$ S_{11, AO} $	15	dB	

Measurement conditions

Ambient temperature $T_A = 25\text{ °C}$

Supply voltage $V_S = 3.6\text{ V}$

LNA and Mixer input signal $f_{RF} = 890\text{ MHz}$, $P_{RF} = -40\text{ dBm}$

LO signal $f_{LO} = 972\text{ MHz}$, $P_{LO} = -6\text{ dBm}$

IF output $f_{IF} = 82\text{ MHz}$

All measurements refer to SMA connectors without consideration of PCB losses

The figures in the mixer section are calculated from a measurement SAW filter + mixer assuming an insertion loss of 3.1dB for the filter at measurement frequency (890MHz).

Parameter	Symbol	typ. Value	Unit	Remarks
Cascade figures				
LNA, resistive 3.1 dB pad (see schematic), SAW filter, mixer				
Cascade Gain	G	18	dB	
Cascade Noise Figure (SSB)	NF	3.35	dB	
3rd order input intercept point	IICP3	-8	dBm	
input 1dB-compression point	P_{1dB}	-17	dBm	

3.3.2 System calculations

Due to the use of a SAW filter for mixer input matching and balancing an isolated measurement of the mixer figures is not possible. The following system calculations have valid entries only for the Gain, IP3, and Noise Figure. The input values are either from extra measurements (e.g. SAW filter insertion loss) or adjusted to give a cascade figure that can be measured (e.g. filter+mixer IP3). All non-fat typeface figures have no meaning.

LNA measurement

Hewlett-Packard	NoiseCalc		AppCAD	
	+----+	+----+		
	- 1 +----	2 +-		
	+----+	+----+		
Noise Figure (dB)	0.10	1.65		
Gain (dB)	-0.10	20.00		
IP3 (dBm)	100.00	20.00		
System Temp. (°C)	25.0		Reference Temperature (°C)	25.0
Input Power (dBm)	-30.0		Noise Bandwidth (MHz)	1.00000
Pout (dBm)	-30.1	-10.1		
Cascade NF (dB)	1.75		Cascade Gain (dB)	19.90
Noise Temperature (°K)	143.9		Input Intercept Point (dBm)	0.1
Signal-to-Noise Ratio (dB)	82.2		Output Intercept Point (dBm)	20.0
Spur Free Dynamic Range (dB)	74.9		IM3 Output Level (dBm)	-70.3
Nominal Detectable Sig (dBm)	-112.2			

- 1) PCB loss
- 2) PMB 2333 LNA

SAW filter and Mixer

Hewlett-Packard	NoiseCalc		AppCAD	
	+----+	+----+		
	- 1 +---	2 +-		
	+----+	+----+		
Noise Figure (dB)	3.10	12.00		
Gain (dB)	-3.10	4.50		
IP3 (dBm)	100.00	11.00		
System Temp. (°C)	25.0		Reference Temperature (°C)	25.0
Input Power (dBm)	-30.0		Noise Bandwidth (MHz)	1.00000
Pout (dBm)	-33.1	-28.6		
Cascade NF (dB)	15.10		Cascade Gain (dB)	1.40
Noise Temperature (°K)	9094.2		Input Intercept Point (dBm)	9.6
Signal-to-Noise Ratio (dB)	68.9		Output Intercept Point (dBm)	11.0
Spur Free Dynamic Range (dB)	72.3		IM3 Output Level (dBm)	-107.8
Nominal Detectable Sig (dBm)	-98.9			

- 1) SAW filter S+M B4672
- 2) PMB 2333 Mixer

Overall figures

Hewlett-Packard	NoiseCalc					AppCAD	
	+----+	+----+	+----+	+----+	+----+		
	- 1 +---	2 +---	3 +---	4 +---	5 +-		
	+----+	+----+	+----+	+----+	+----+		
Noise Figure (dB)	0.10	1.65	3.10	3.10	12.00		
Gain (dB)	-0.10	20.00	-3.10	-3.10	4.50		
IP3 (dBm)	200.00	20.00	200.00	40.00	11.00		
System Temp. (°C)	25.0					Reference Temperature (°C)	25.0
Input Power (dBm)	-30.0					Noise Bandwidth (MHz)	1.00000
Pout (dBm)	-30.1	-10.1	-13.2	-16.3	-11.8		
Cascade NF (dB)	3.35					Cascade Gain (dB)	18.20
Noise Temperature (°K)	337.0					Input Intercept Point (dBm)	-7.9
Signal-to-Noise Ratio (dB)	80.7					Output Intercept Point (dBm)	10.3
Spur Free Dynamic Range (dB)	68.5					IM3 Output Level (dBm)	-55.9
Nominal Detectable Sig (dBm)	-110.6						

- 1) PCB loss
- 2) PMB 2333 LNA
- 3) Resistive pad, 3.1dB attenuation
- 4) SAW filter S+M B4672
- 5) PMB 2333 Mixer

3.3.3 Measurement results

Cascaded figure measurements

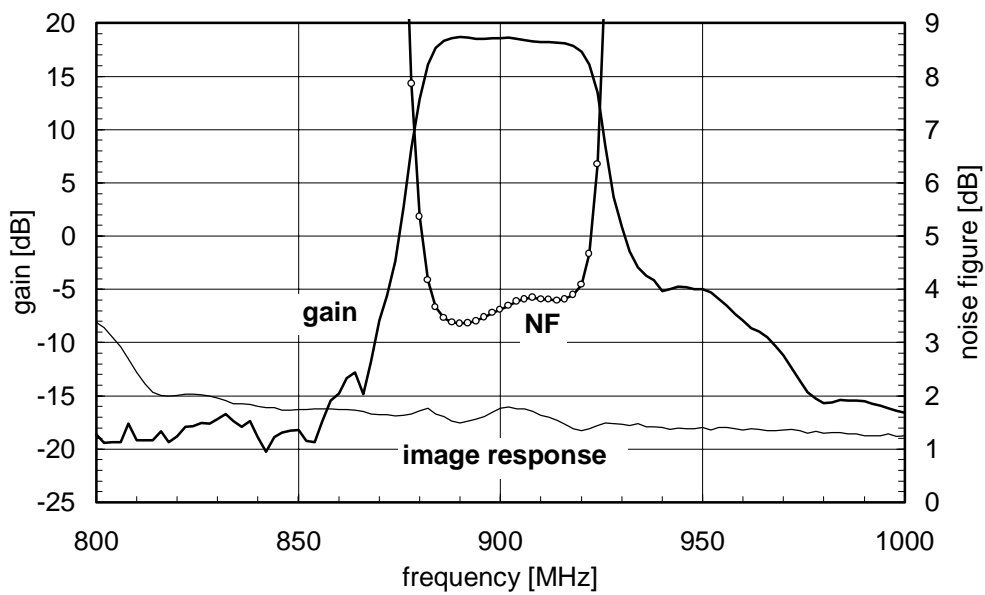

Figure 24: Cascade gain, SSB noise figure versus frequency

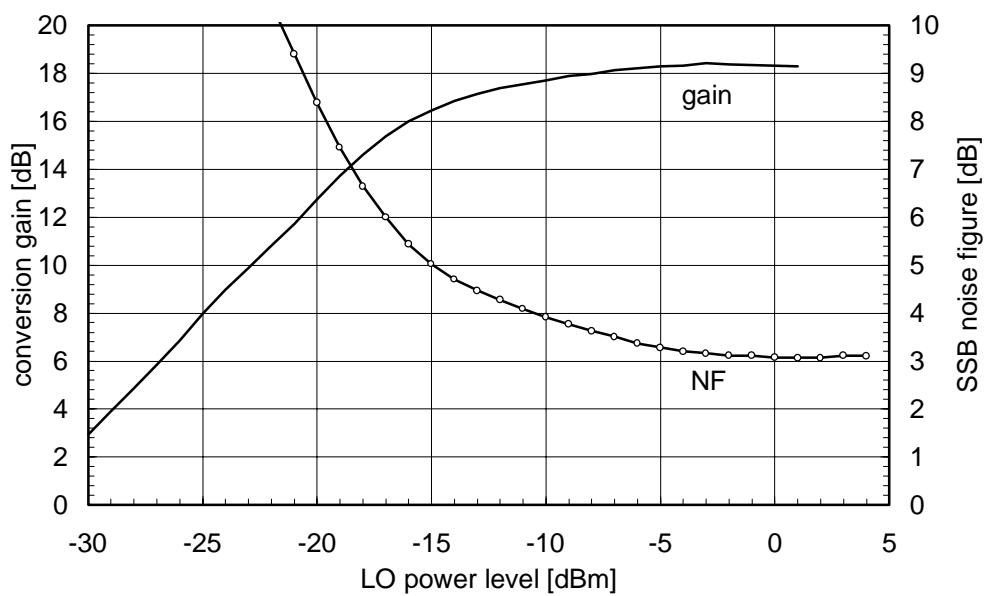

Figure 25: Cascade gain, SSB noise figure versus LO power

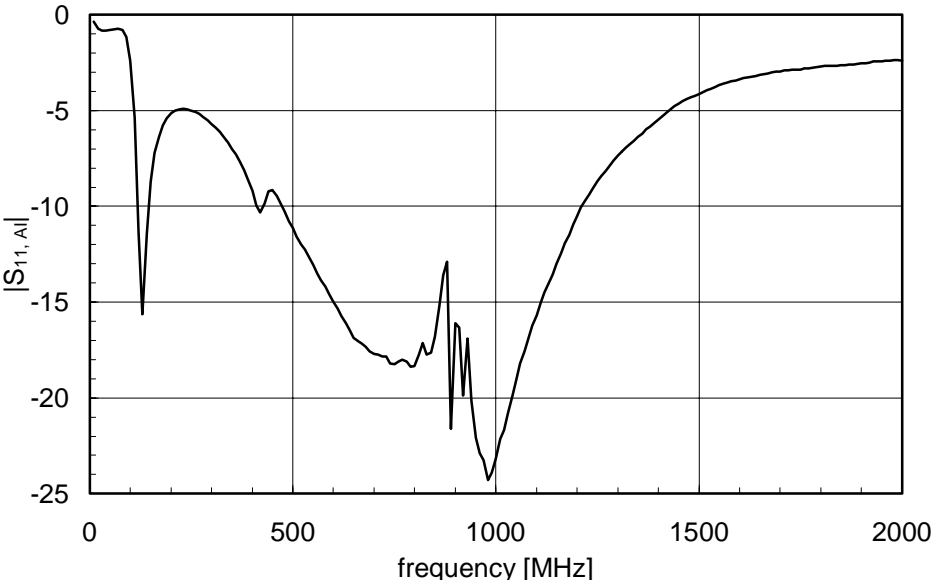

Figure 26: AI input return loss versus frequency

3.3.4 Circuit diagram and PCB layout

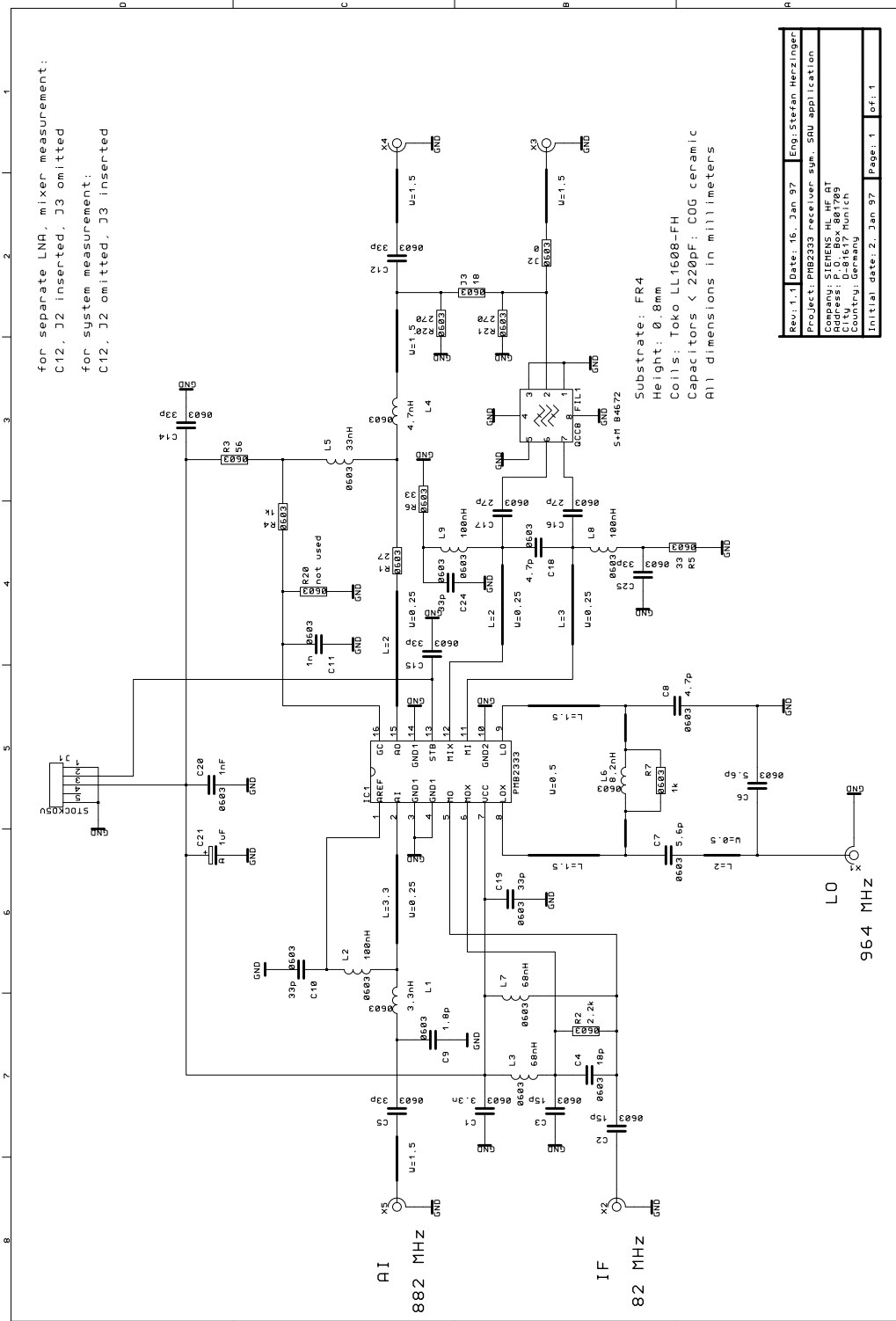

Figure 27: Circuit diagram

PCB dimensions: 80 x 50 mm

Substrate material: FR4

Substrate height: 0.8 mm

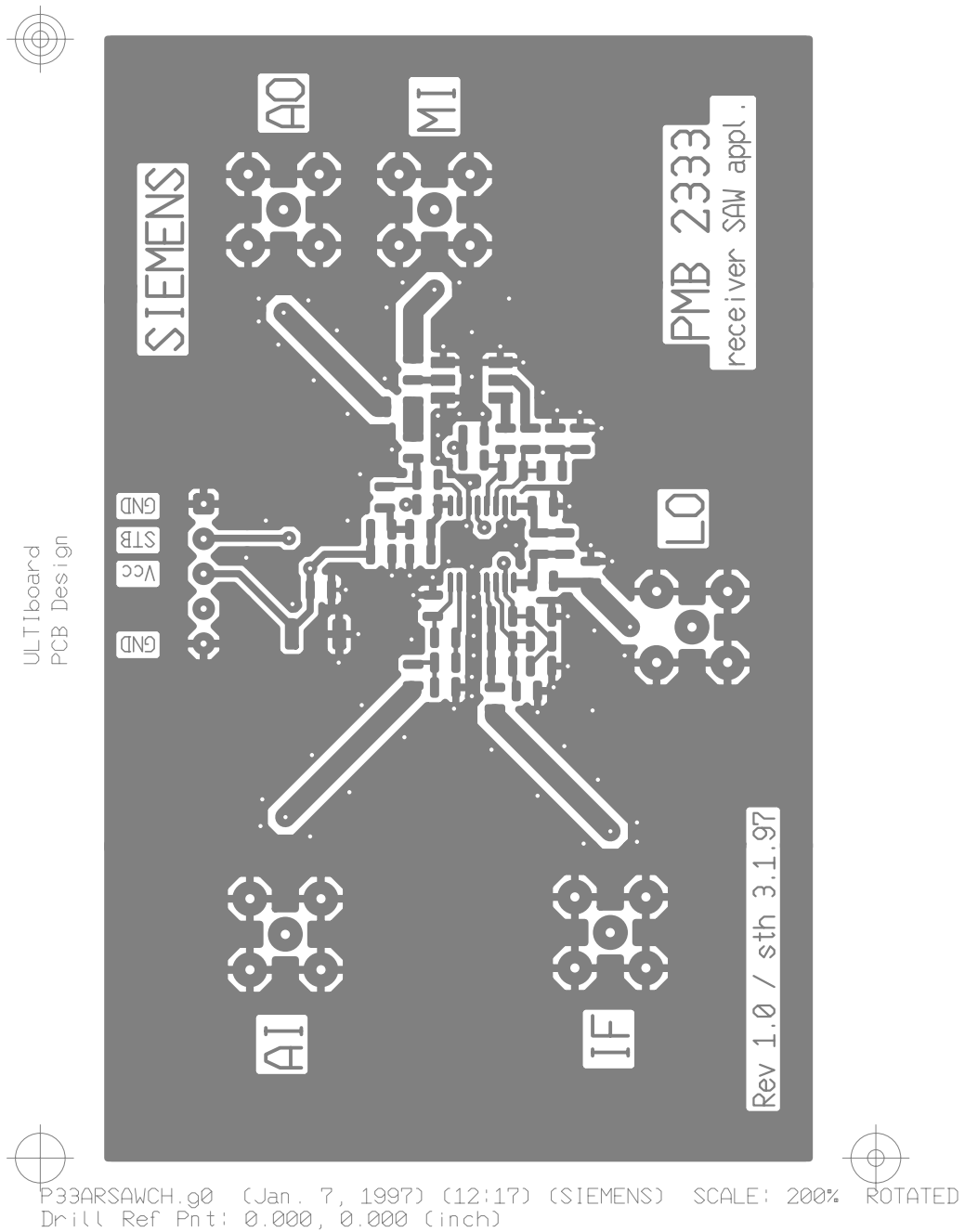

Figure 28: PCB top side

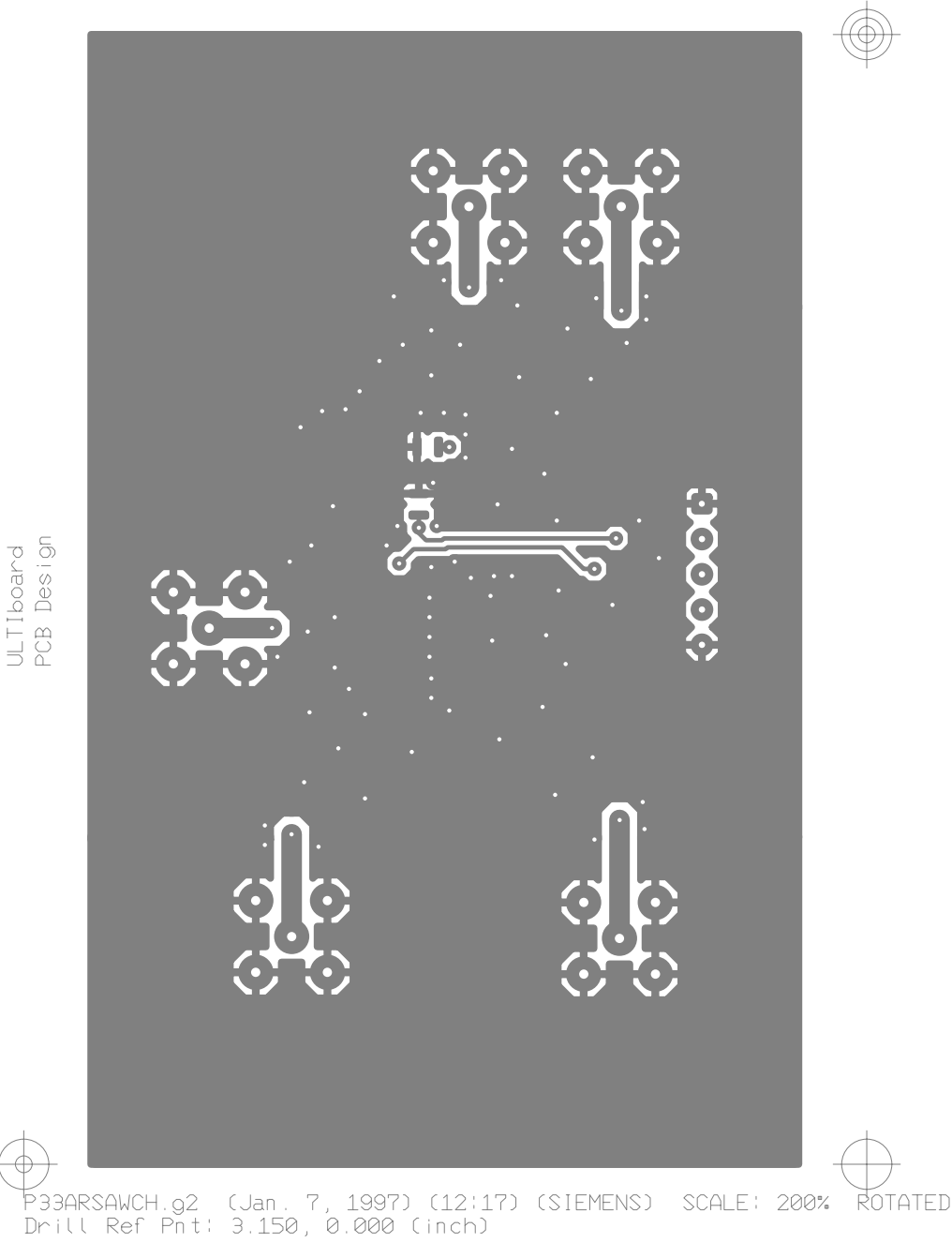

Figure 29: PCB bottom side

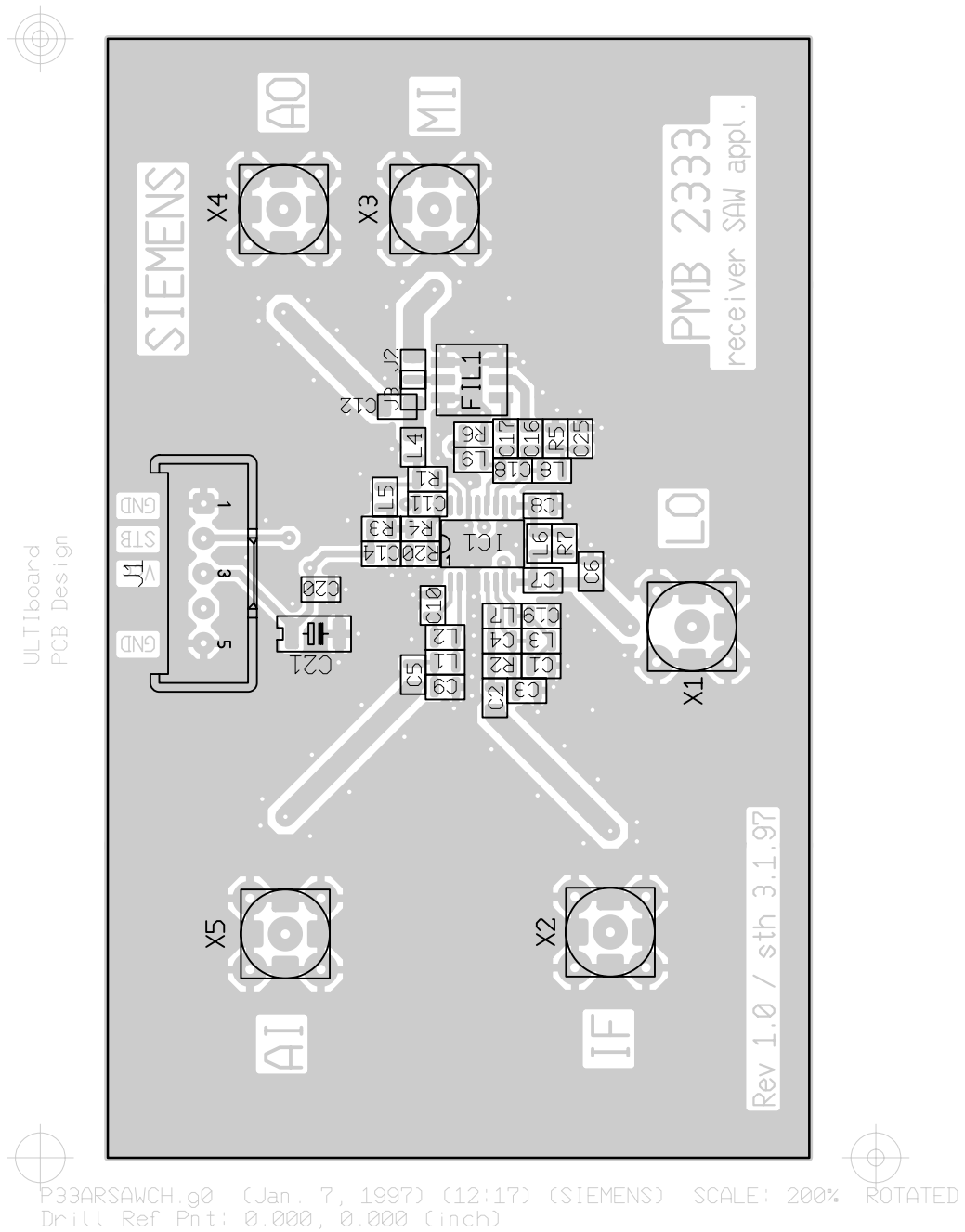

Figure 30: PCB component placement top

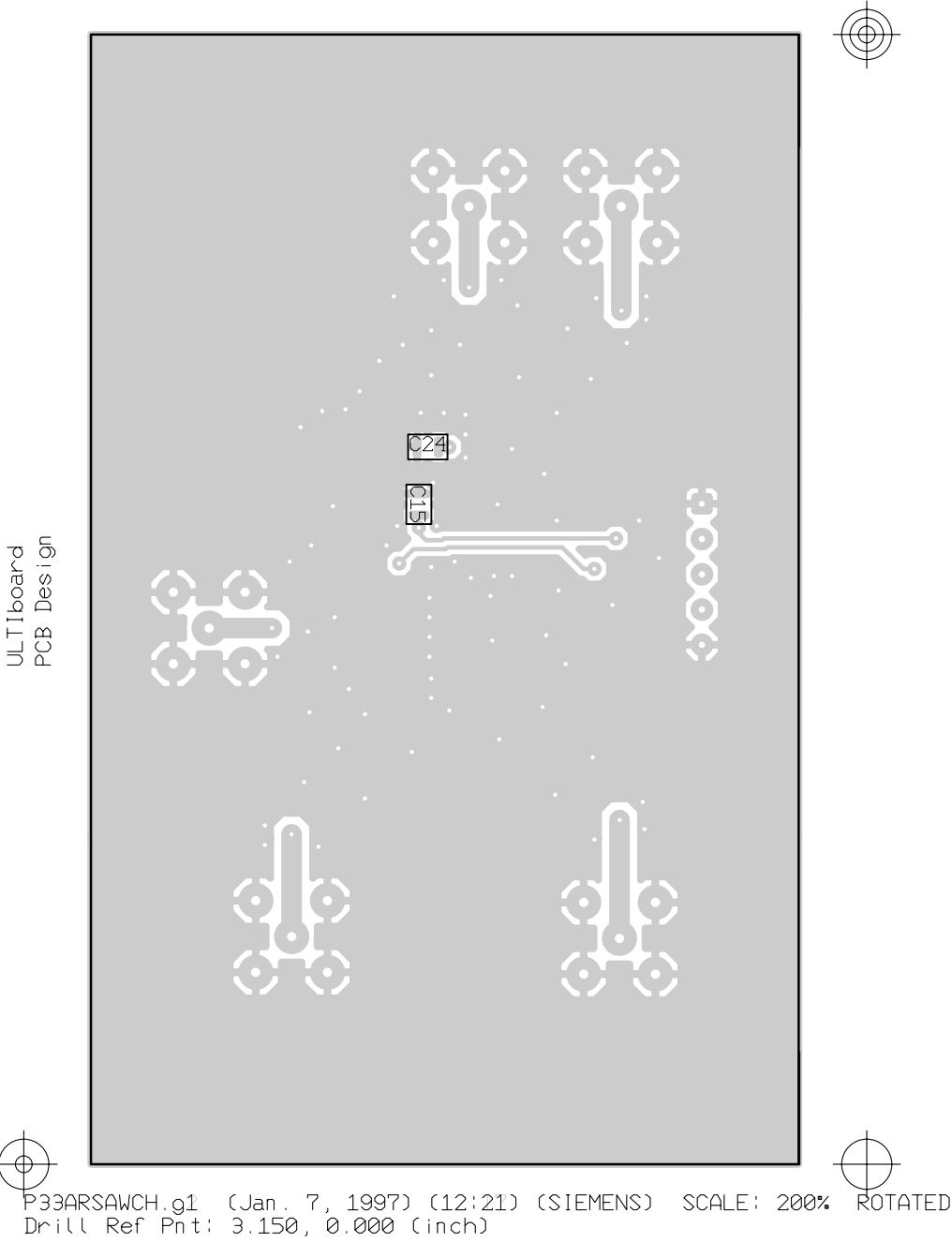

Figure 31: PCB component placement bottom

Receiver/SAW Application - List of Components

Item	Quantity	Reference	Value	Part	
1	1	C9	1.8 pF	SMD/0603	
2	2	C8, C18	4.7 pF	SMD/0603	
3	2	C6, C7	5.6 pF	SMD/0603	
4	2	C2, C3	15 pF	SMD/0603	
5	1	C4	18 pF	SMD/0603	
6	2	C16, C17	27 pF	SMD/0603	
7	8	C5, C10, C12, C14, C15, C19, C24, C25	33 pF	SMD/0603	
8	2	C11, C20	1 nF	SMD/0603	
9	1	C1	3.3 nF	SMD/0603	
10	1	C21	1 μ F	SMD/A	Tantalum
11	1	J2	0 Ω	SMD/0603	
12	1	R1	27 Ω	SMD/0603	
13	2	R5, R6	33 Ω	SMD/0603	
14	1	R3	56 Ω	SMD/0603	
15	2	R4, R7	1.0 k Ω	SMD/0603	
16	1	L1	3.3 nH	SMD/0603	Toko LL1608-FH
17	1	L4	4.7 nH	SMD/0603	Toko LL1608-FH
18	1	L6	8.2 nH	SMD/0603	Toko LL1608-FH
19	1	L5	33 nH	SMD/0603	Toko LL1608-FH
20	2	L3, L7	68 nH	SMD/0805	Toko LL1608-FH
21	3	L2, L8, L9	100 nH	SMD/0805	Toko LL1608-FH
22	1	IC1	PMB 2333	Siemens	
23	1	FIL1	B4672	S+M	
24	1	J1	connector	Stocko MKS 1655-6-0-505	
25	5	X1, X2, X3, X4, X5	SMA connector	Suhner 82 SMA 50-0-41 or Rosenberger 32 K 141-400A2	

4 Package Outlines

P-TSSOP-16
(Plastic Package)

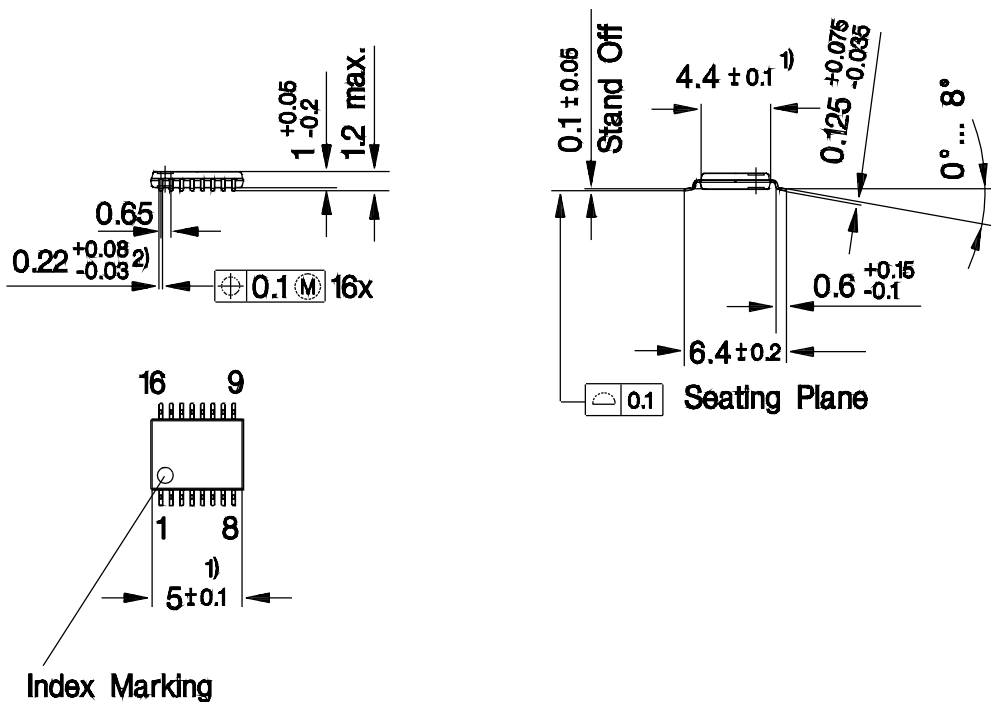

- 1) Does not include plastic or metal protrusion of 0.15 max. per side
- 2) Does not include dambar protrusion of 0.08 max. per side

Sorts of Packing

Package outlines for tubes, trays etc. are contained in our Data Book "Package Information".

SMD = Surface Mounted Device

Dimensions in mm