

DISCRETE SEMICONDUCTORS

DATA SHEET

PMBF4391; PMBF4392; PMBF4393 N-channel FETs

Product specification
File under Discrete Semiconductors, SC07

April 1995

N-channel FETs

**PMBF4391;
PMBF4392; PMBF4393**

DESCRIPTION

Symmetrical silicon n-channel depletion type junction field-effect transistors on a plastic microminiature envelope intended for application in thick and thin-film circuits. The transistors are intended for low-power chopper or switching applications in industry.

PINNING

- 1 = drain
- 2 = source
- 3 = gate

Note

1. Drain and source are interchangeable.

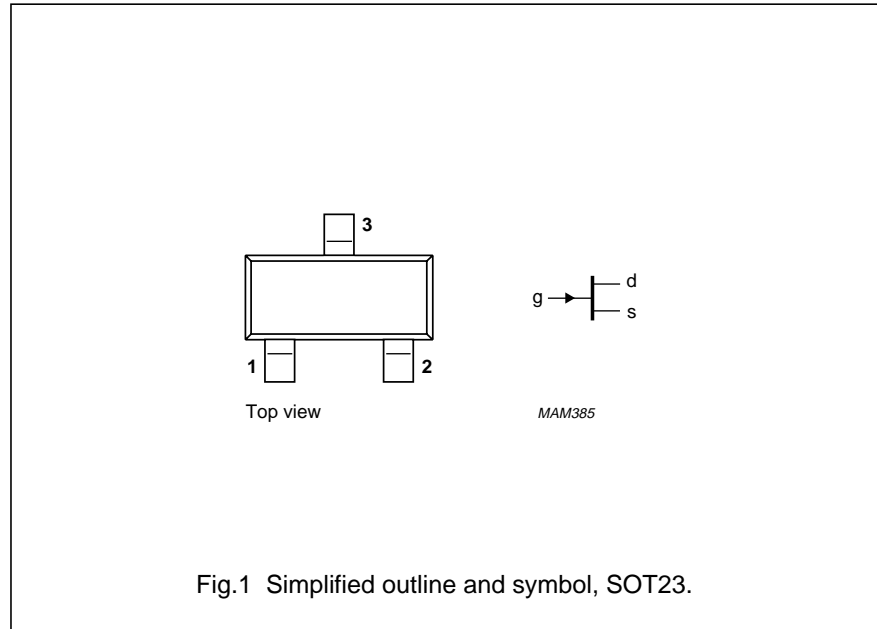

Marking code

- PMBF4391 = p6J
- PMBF4392 = p6K
- PMBF4393 = p6G

QUICK REFERENCE DATA

		PMBF4391		PMBF4392	PMBF4393	
Drain-source voltage	$\pm V_{DS}$	max.	40	40	40	V
Drain current						
$V_{DS} = 20\text{ V}; V_{GS} = 0$	I_{DSS}	>	50	25	5	mA
Gate-source cut-off voltage						
$V_{DS} = 20\text{ V}; I_D = 1\text{ nA}$	$-V_{(P)GS}$	>	4	2	0.5	V
		<	10	5	3	V
Drain-source resistance (on) at $f = 1\text{ kHz}$						
$I_D = 0; V_{GS} = 0$	$R_{ds\ on}$	<	30	60	100	Ω
Feedback capacitance at $f = 1\text{ MHz}$						
$-V_{GS} = 12\text{ V}; V_{DS} = 0$	C_{rs}	<	3.5	3.5	3.5	pF
Turn-off time						
$V_{DD} = 10\text{ V}; V_{GS} = 0$						
$I_D = 12\text{ mA}; -V_{GSM} = 12\text{ V}$	t_{off}	<	20	–	–	ns
$I_D = 6\text{ mA}; -V_{GSM} = 7\text{ V}$	t_{off}	<	–	35	–	ns
$I_D = 3\text{ mA}; -V_{GSM} = 5\text{ V}$	t_{off}	<	–	–	50	ns

N-channel FETs

PMBF4391; PMBF4392;
PMBF4393**RATINGS**

Limiting values in accordance with the Absolute Maximum System (IEC 134)

Drain-source voltage	$\pm V_{DS}$	max.	40 V
Drain-gate voltage	V_{DGO}	max.	40 V
Gate-source voltage	$-V_{GSO}$	max.	40 V
Gate current (DC)	I_G	max.	50 mA
Total power dissipation up to $T_{amb} = 40\text{ }^\circ\text{C}$ (1)	P_{tot}	max.	250 mW
Storage temperature range	T_{stg}		-65 to +150 °C
Junction temperature	T_j	max.	150 °C

THERMAL RESISTANCE

From junction to ambient ⁽¹⁾	$R_{th\ j-a}$	=	430 K/W
---	---------------	---	---------

CHARACTERISTICS $T_j = 25\text{ }^\circ\text{C}$ unless otherwise specified

Gate-source voltage

$I_G = 1\text{ mA}; V_{DS} = 0$	V_{GSon}	<	1 V
---------------------------------	------------	---	-----

Gate-source cut-off current

$V_{DS} = 0\text{ V}; -V_{GS} = 20\text{ V}$	$-I_{GSS}$	<	0.1 nA
--	------------	---	--------

$V_{DS} = 0\text{ V}; -V_{GS} = 20\text{ V}; T_{amb} = 150\text{ }^\circ\text{C}$	$-I_{GSS}$	<	0.2 μA
---	------------	---	-------------------

	PMBF4391	PMBF4392	PMBF4393
--	----------	----------	----------

Drain current

$V_{DS} = 20\text{ V}; V_{GS} = 0$	I_{DSS}	>	50	25	5 mA
		<	150	75	30 mA

Gate-source breakdown voltage

$-I_G = 1\text{ }\mu\text{A}; V_{DS} = 0$	$-V_{(BR)GSS}$	>	40	40	40 V
---	----------------	---	----	----	------

Gate-source cut-off voltage

$I_D = 1\text{ nA}; V_{DS} = 20\text{ V}$	$-V_{(P)GS}$	>	4	2	0.5 V
		<	10	5	3 V

Drain-source voltage (on)

$I_D = 12\text{ mA}; V_{GS} = 0$	V_{DSon}	<	0.4	-	- V
----------------------------------	------------	---	-----	---	-----

$I_D = 6\text{ mA}; V_{GS} = 0$	V_{DSon}	<	-	0.4	- V
---------------------------------	------------	---	---	-----	-----

$I_D = 3\text{ mA}; V_{GS} = 0$	V_{DSon}	<	-	-	0.4 V
---------------------------------	------------	---	---	---	-------

Drain-source resistance (on)

$I_D = 0; V_{GS} = 0; f = 1\text{ kHz}; T_{amb} = 25\text{ }^\circ\text{C}$	$r_{ds\ on}$	<	30	-	100 Ω
---	--------------	---	----	---	--------------

Drain cut-off current

$-V_{GS} = 12\text{ V}$	$V_{DS} = 20\text{ V}$	I_{DSX}	<	0.1	-	- nA
-------------------------	------------------------	-----------	---	-----	---	------

$-V_{GS} = 7\text{ V}$			<	-	0.1	- nA
------------------------	--	--	---	---	-----	------

$-V_{GS} = 5\text{ V}$			<	-	-	0.1 nA
------------------------	--	--	---	---	---	--------

$-V_{GS} = 12\text{ V}$	$V_{DS} = 20\text{ V}; T_{amb} = 150\text{ }^\circ\text{C}$	I_{DSX}	<	0.2	-	- μA
-------------------------	---	-----------	---	-----	---	-----------------

$-V_{GS} = 7\text{ V}$			<	-	0.2	- μA
------------------------	--	--	---	---	-----	-----------------

$-V_{GS} = 5\text{ V}$			<	-	-	0.2 μA
------------------------	--	--	---	---	---	-------------------

N-channel FETs

PMBF4391; PMBF4392;
PMBF4393

y-parameters (common source)

$V_{DS} = 20\text{ V}$; $V_{GS} = 0$; $f = 1\text{ MHz}$; $T_{amb} = 25\text{ }^\circ\text{C}$

			PMBF4391	PMBF4392	PMBF4393
Input capacitance	C_{is}	<	14	14	14 pF
Feedback capacitance					
$-V_{GS} = 12\text{ V}$; $V_{DS} = 0$	C_{rs}	<	3.5	–	– pF
$-V_{GS} = 7\text{ V}$; $V_{DS} = 0$	C_{rs}	<	–	3.5	– pF
$-V_{GS} = 5\text{ V}$; $V_{DS} = 0$	C_{rs}	<	–	–	3.5 pF
Switching times					
$V_{DD} = 10\text{ V}$; $V_{DS} = 0$					
Conditions I_D and $-V_{GSoff}$					
	I_D	=	12	6	3 mA
	$-V_{GSoff}$	=	12	7	5 V
	R_L	=	750	1550	3150 Ω
Rise time	t_r	<	5	5	5 ns
Turn on time	t_{on}	<	15	15	15 ns
Fall time	t_f	<	15	20	30 ns
Turn off time	t_{off}	<	20	35	50 ns

Note

1. Mounted on a ceramic substrate of 8 mm × 10 mm × 0,7 mm.

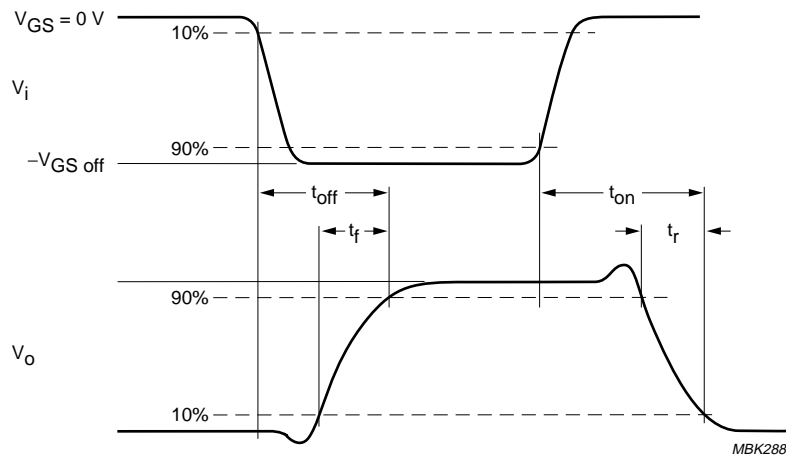
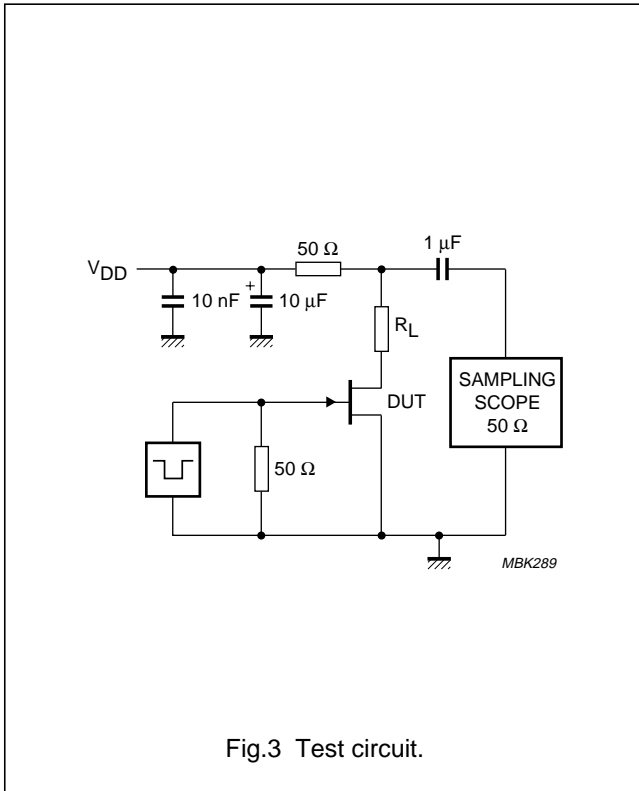

Fig.2 Switching times waveforms.

N-channel FETs

PMBF4391; PMBF4392;
PMBF4393



Pulse generator:

$$t_r < 0.5 \text{ ns}$$

$$t_f < 0.5 \text{ ns}$$

$$t_p = 100 \text{ } \mu\text{s}$$

$$\delta = 0.01$$

Oscilloscope:

$$R_i = 50 \text{ } \Omega$$

Fig.3 Test circuit.

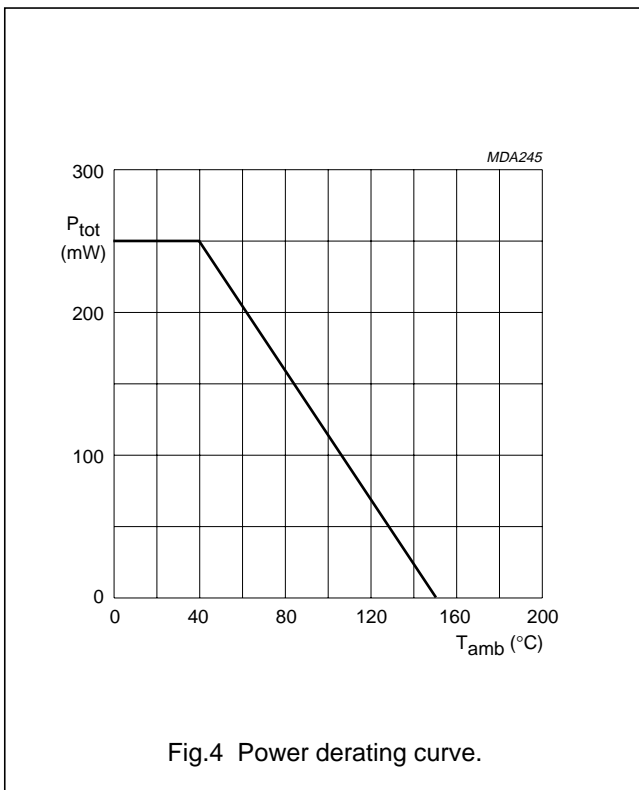

Fig.4 Power derating curve.

N-channel FETs

PMBF4391; PMBF4392;
PMBF4393

PACKAGE OUTLINE

Plastic surface mounted package; 3 leads

SOT23

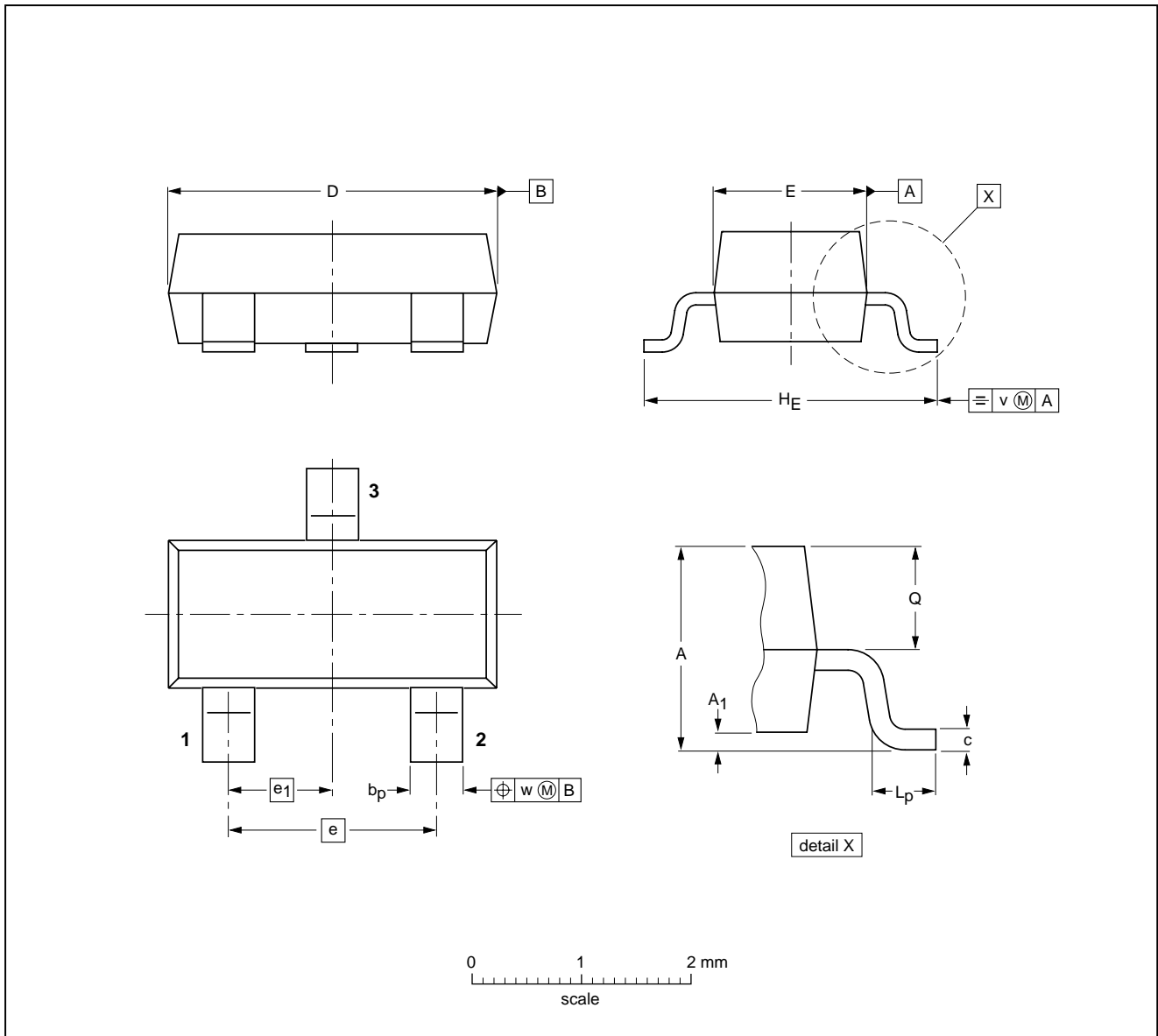

DIMENSIONS (mm are the original dimensions)

UNIT	A	A ₁ max.	b _p	c	D	E	e	e ₁	H _E	L _p	Q	v	w
mm	1.1 0.9	0.1	0.48 0.38	0.15 0.09	3.0 2.8	1.4 1.2	1.9	0.95	2.5 2.1	0.45 0.15	0.55 0.45	0.2	0.1

OUTLINE VERSION	REFERENCES				EUROPEAN PROJECTION	ISSUE DATE
	IEC	JEDEC	EIAJ			
SOT23						97-02-28

N-channel FETs

PMBF4391; PMBF4392;
PMBF4393**DEFINITIONS**

Data sheet status	
Objective specification	This data sheet contains target or goal specifications for product development.
Preliminary specification	This data sheet contains preliminary data; supplementary data may be published later.
Product specification	This data sheet contains final product specifications.
Short-form specification	The data in this specification is extracted from a full data sheet with the same type number and title. For detailed information see the relevant data sheet or data handbook.
Limiting values	
Limiting values given are in accordance with the Absolute Maximum Rating System (IEC 134). Stress above one or more of the limiting values may cause permanent damage to the device. These are stress ratings only and operation of the device at these or at any other conditions above those given in the Characteristics sections of the specification is not implied. Exposure to limiting values for extended periods may affect device reliability.	
Application information	
Where application information is given, it is advisory and does not form part of the specification.	

LIFE SUPPORT APPLICATIONS

These products are not designed for use in life support appliances, devices, or systems where malfunction of these products can reasonably be expected to result in personal injury. Philips customers using or selling these products for use in such applications do so at their own risk and agree to fully indemnify Philips for any damages resulting from such improper use or sale.