

HIC for 5-Phase Stepping Motor

PMM5301 PMM5303

Outline

PMM530 □ is a single packaged power hybrid IC of the switching elements to be used for driving 5-phase stepping motor. This HIC has been developed for the purpose to further simplify the usage of 5-phase stepping motor. When combined only with the controller IC to generate the excitation mode, this HIC can configure a driver device for a 5-phase stepping motor.

Characteristics

- High speed and high torque rotation by 5-phase pentagon system.
- Constant voltage and constant current PWM driving system (excited by others).
- Power voltage (driving power) : VCC1=18~42V
- High output current : 4A max. (1A/phase)
- Reduced heat generation by using MOSFET for the power drive element.
- The all-in-one packaging reduces number of parts around peripheral circuits.
- Two package types are available, enabling flexible PCB designing.

Maximum rating (Tc = 25°C)

Item	Symbol	Condition	Rated value	Unit
Power voltage-1	V _{CC1 max}	Without signal (25pin terminal)	52	V
Power voltage-2	V _{CC2 max}	Without signal (5pin terminal)	7	V
Power voltage-3	V _{CC3 max}	FET drive power (6pin terminal)	15	V
Phase current	I _{O max}	1 pulse 100ms, T _c =25°C	7	A
Loss-1	P _{D max1}	Single FET for phase switching, T _c =25°C	12.5	W
Loss-2	P _{D max2}	Single FET for constant current control, T _c =25°C	27	W
Operating temperature on PCB	T _c	No-condensing at a low temperature	0~105	°C
Temperature at joint	T _{J max}	—————	150	°C
Storage temperature	T _{stg}	—————	-40~125	°C

Recommended operation condition (Ta = 25°C)

Item	Symbol	Condition	Rated value	Unit
Power voltage-1	V _{CC1}	With signal (25pin terminal)	18~42	V
Power voltage-2	V _{CC2}	With signal (5pin terminal)	5.0±5%	V
Power voltage-3	V _{CC3}	With signal (6pin terminal)	12.0±10%	V
Power voltage-4	V _{CC0}	With signal (24pin terminal)	10~42	V
Output current	I _{O max}	Total current	4	A
Phase driver withstanding voltage	V _{DSS}	ID=10mA(TC=25°C)	60min	V

Dimensions (Unit: mm)

Pin No.	Code	Functions
1	OCRFB	Set input for motor current
2	RS2	Detecting terminal for motor current
3	GND	0V
4	RS3	0V
5	VCC2	5V system power
6	VCC3	12V system power
7	NA	Lower arm drive input
8	ND	Lower arm drive input
9	NE	Lower arm drive input
10	NC	Lower arm drive input
11	NB	Lower arm drive input
12	RS1	Input voltage applied to motor
13	AO	Motor output
14	BO	Motor output
15	CO	Motor output
16	DO	Motor output
17	EO	Motor output
18	VM	Input voltage applied to motor
19	PC	Upper arm drive input
20	PA	Upper arm drive input
21	PB	Upper arm drive input
22	PD	Upper arm drive input
23	PE	Upper arm drive input
24	VCCO	Output terminal for power source
25	VCC1	Power system input

● PMM5301

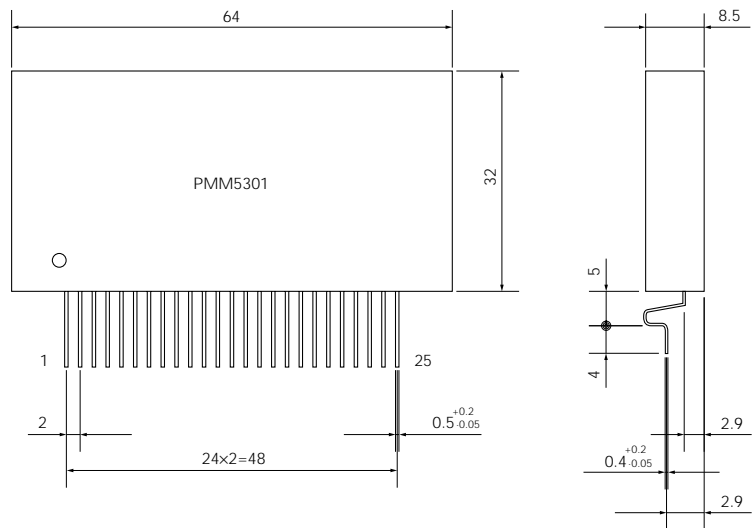

● PMM5303

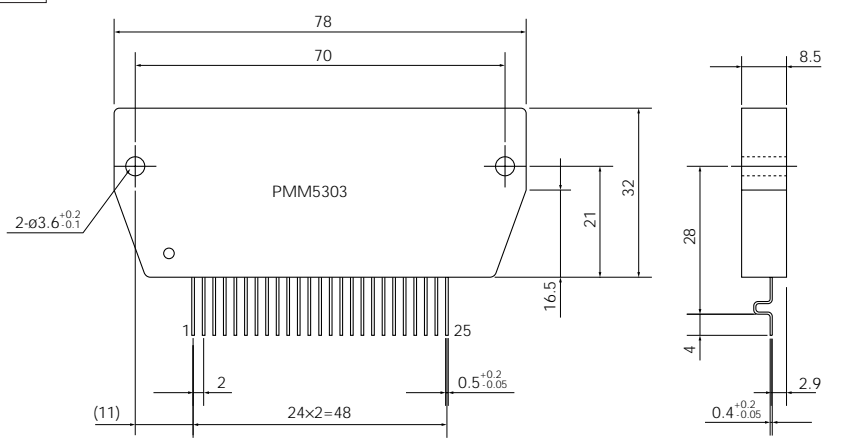

Electrical characteristics (Tc = 25°C, VCC1 = 24V, VCC2 = 5V, VCC3 = 12V)

Item	Symbol	Condition	Rating			Unit
			Min.	Standard	Max.	
Oscillation frequency	Fc	—	20	25	30	kHz
"H" level input voltage	V _{IH}	NA-NE terminals	2.0	—	—	V
"L" level input voltage	V _{IL}	NA-NE terminals	—	—	0.8	
"H" level input voltage	V _{IH}	PA-PE terminals	3.5	—	—	V
"L" level input voltage	V _{IL}	PA-PE terminals	—	—	1.5	
Input current	I _I	PA-PE terminals V _{IN} =VCC2 or GND	—	—	±1	μA
"H" level input current	I _{OH}	NA-NE terminals V _{IN} =2.7V	—	—	20	μA
"L" level input current	I _{OL}	NA-NE terminals V _{IN} =0.4V	—	—	-0.4	mA
VCC2 current consumption	I _{CCO2}	5 pin terminal	—	23	45	mA
VCC3 current consumption	I _{CCO3}	6 pin terminal	—	15	25	mA

Example application circuit

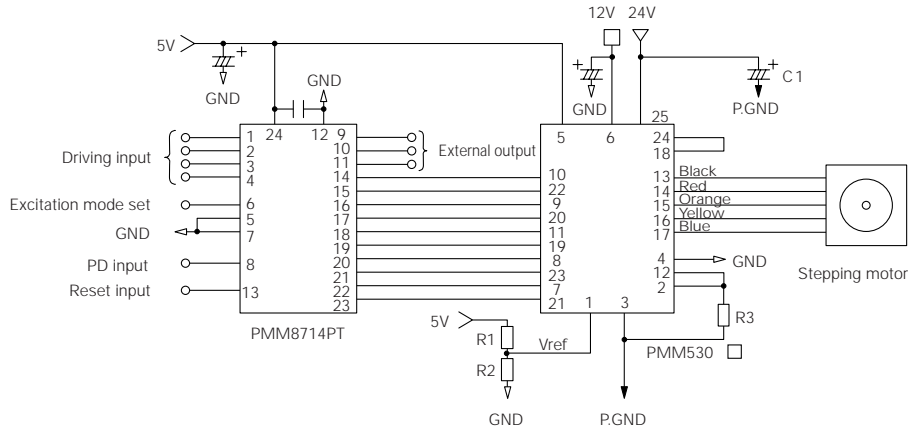

- Make common for the logic system grounding (GDN) and the driving power system grounding on the C1 minus side.
- Refer to Page 337 for the specifications of PMM8714PT.
- Recommended fixed numbers of circuit for PMM530 □ :

Applied for	Constant value
R3	5W 0.5Ω
C1	330 μF

- Select the fixed numbers R1 and R2 referring to the Vref-output current characteristics.
- The value shown in the graph was measured during operation of 103H7521-7051.

The Vref voltage differs according to the combined motor, power voltage and pattern status of PCB. For protection of the motor and hybrid IC, actual motor current may have to be measured under the using conditions.

