

5-Phase Stepping Motor Drive IC for Universal Controller

PMM8714PT

Outline

"PMM8714PT" is a Bi-CMOS monolithic IC to be used for controlling 5-phase stepping motor. This IC has been developed for the purpose to further simplify the usage of 5-phase stepping motor. When combined only with the switching elements or a power hybrid IC, this IC can configure a driver device for a 5-phase stepping motor.

Characteristics

- Universal controller : Selection is possible from the following three different excitation modes.
4EX/4-5EX/5EX
- Power voltage: : Vcc=4V~16V
- High output current: : 20mA min(source)
- High noise margin : Schmitt trigger circuit is integrated for the all input terminals
- two kinds of pulse input : double input system (CW, CCW input mode), single input system (CK,U/D input mode)
- Power-down functions : Makes all the output to "L" level.
- Reset functions : Shifts excitation status to the phase origin.
- Excitation mode preservation functions : Phase output does not change even when excitation mode is switched as follows: 4EX_4-5EX_5EX.
- Phase origin monitor : Outputs at the "H" level at the time of phase origin (the output in reset mode).
- Determination monitor for excitation status : Outputs monitor signal for the status of controller.
- Input pulse monitor : Outputs monitor signal for Vcc input pulse.

Maximum Rating (Ta = 25\$→\$C)

Item	Symbol	Rating	Unit
Power voltage	Vcc	-0.5~20	V
Output current ø n	"H" level IoH ø	-30	mA
	"L" level IoL ø	2	
Output current Co,Em,Zo	"H" level IoH	-50	µ A
	"L" level IoL	2	
Input voltage	VIN	-0.5~Vcc	V
Input current	IIN	±1	mA
Tolerated loss	Pd	1000	mW
Operating temperature	Topr	-20~85	°C
Storage temperature	Tstg	-55~150	°C

Recommended Operating Conditions (Ta = -30 to 85-C)

Item	Symbol	Rating			Unit
		Min.	Standard	Max.	
Power voltage	Vcc	4	—	16	V
Output current ø n	"H" level IoH ø	—	—	-10	mA
	"L" level IoL ø	—	—	1.6	
Output current Co,Em,Zo	"H" level IoH	—	—	-40	µ A
	"L" level IoL	—	—	1.6	
Input voltage	VIN	0	—	Vcc	V
Clock frequency	—	0	—	250	kHz

Dimensions (unit: mm)

Pin No.	Name	Function
1.	C _U	Input pulse UP clock input
2.	C _D	Input pulse DOWN clock input
3.	C _K	Input pulse clock input
4.	U/D	Alters rotation direction
5.	E _A	Input to switch excitation mode
6.	E _B	Input to switch excitation mode
7.	E _C	Input to switch excitation mode
8.	P _D	Power down input
9.	Z _O	Phase origin monitor output
10.	C _O	Input pulse monitor output
11.	E _M	Excitation monitor output
12.	GND	0V
13.	R̄	Reset input
14.	ø Ē	ø Ē output
15.	ø D̄	ø D̄ output
16.	ø C̄	ø C̄ output
17.	ø B̄	ø B̄ output
18.	ø Ā	ø Ā output
19.	ø E	ø E output
20.	ø D	ø D output
21.	ø C	ø C output
22.	ø B	ø B output
23.	ø A	ø A output
24.	V _{CC}	4-16V

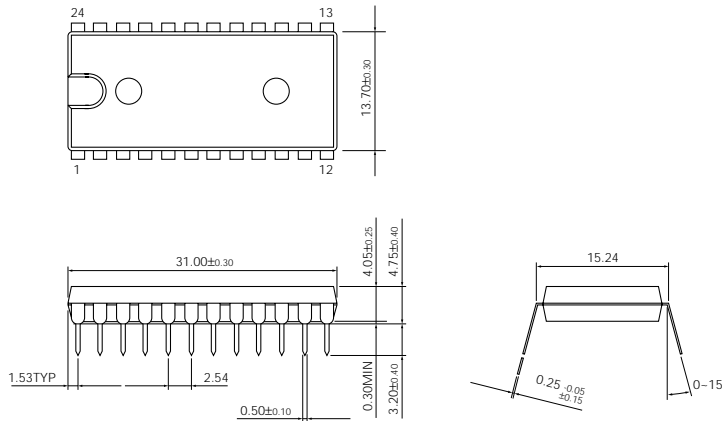

Electrical characteristics

Direct Current Characteristics (T_a=25°C)

Item	Symbol	V _{CC} [V]	Conditions	Standard Value			Unit
				Min.	Standard	Max.	
Output current ø A-ø Ē	"H" level	5	V _O = V _{CC} -2.0	-20	—	—	mA
		10		-20	—	—	
	"L" level	5	V _O = 0.3V	1.6	—	—	
		10		1.6	—	—	
Output voltage C _O ,E _M ,Z _O	"H" level	5	I _O = -40μA	3.6	—	—	V
		10		8.6	—	—	
	"L" level	5	I _O = 1.6mA	—	—	0.4	
		10		—	—	0.6	
Input voltage	"H" level	5	—————	3.0	2.5	—	V
		10		6.0	5.0	—	
	"L" level	5	—————	—	2.0	1.5	
		10		—	4.0	3.0	
Input voltage C _U ,C _D ,C _K E _A ,E _B ,E _C	"H" level	5	V _{IN} = V _{CC} -0.5	—	—	0.4	mA
		10		—	—	0.7	
	"L" level	5	V _{IN} = 0V	—	—	±10	μA
		10		—	—	±10	
Input voltage U/D,PD,R	"H" level	5	V _{IN} = V _{CC} -0.5	—	—	-100	μA
		10		—	—	-100	
	"L" level	5	V _{IN} = 0V	—	—	-0.4	mA
		10		—	—	-0.7	
Static current consumption	I _{CC}	5	All terminals open	—	—	25	mA
		10		—	—	35	

Electrical characteristics

Switching Characteristics (Ta=25°C)

Item	Symbol	VCC [V]	Conditions	Standard Value			Unit
				Min.	Standard	Max.	
Max. clock frequency	f _{MAX}	5	-----	250	300	—	kHz
		10		270	350	—	
Min. clock pulse width	t _w	5	-----	—	300	500	ns
		10		—	300	500	
Min. reset pulse width	t _{wR}	5	-----	—	200	500	ns
		10		—	200	500	
Delay time (ø output from clock input)	t _{PHL}	5	-----	—	2500	3500	ns
		10		—	2500	3500	
Delay time (Each monitoring from clock input)	t _{PLH}	5	-----	—	3000	4000	ns
		10		—	3000	4000	
Preset time	t _{SET}	5	-----	4000	3000	—	ns
		10		4000	3000	—	
Holding time	t _{HOLD}	5	-----	500	0	—	ns
		10		500	0	—	

Switching Characteristics

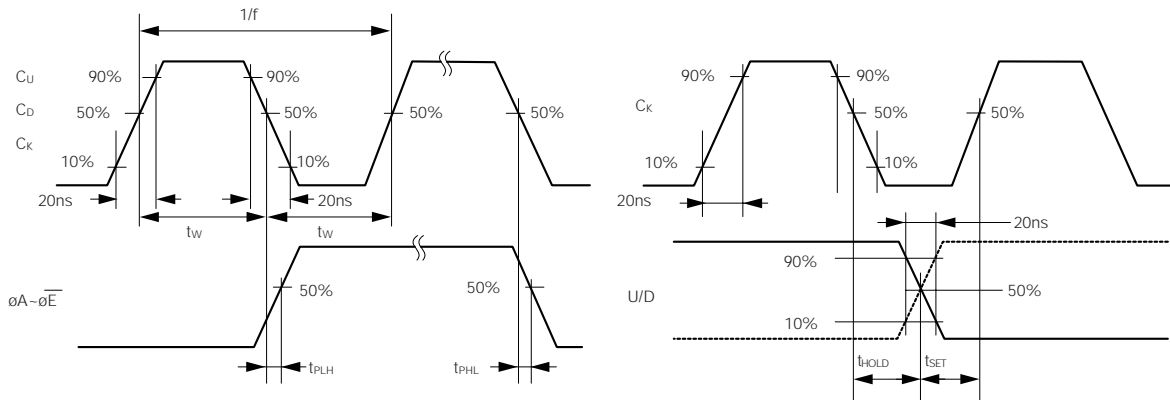

Function table

Input mode and rotating direction

Input system	Input				Rotation direction
	C_U	C_D	C_K	U/D	
Double input system (CW,CCW)	\bar{L}	L	L	L	CW
	L	\bar{L}	L	L	CCW
Single input system (CK,U/D)	L	L	\bar{L}	H	CW
	L	L	\bar{L}	L	CCW

Excitation mode

Energization system	Input				
	\bar{R}	\bar{P}_D	E_A	E_B	E_C
4 EX	H	H	L	H	L
4-5EX	H	H	L	L	L
5 EX	H	H	H	L	L

Energization sequence

4EX

Pulse / Phase	0 (Reset)	1	2	3	4	5	6	7	8	9	10
ø A	1	0	0	0	0	0	0	1	1	1	1
ø B	1	1	0	0	0	0	0	0	1	1	1
ø C	1	1	1	0	0	0	0	0	0	1	1
ø D	1	1	1	1	0	0	0	0	0	0	1
ø E	0	1	1	1	1	0	0	0	0	0	0
ø \bar{A}	0	0	1	1	1	1	0	0	0	0	0
ø \bar{B}	0	0	0	1	1	1	1	0	0	0	0
ø \bar{C}	0	0	0	0	1	1	1	1	0	0	0
ø \bar{D}	0	0	0	0	0	1	1	1	1	0	0
ø \bar{E}	0	0	0	0	0	0	1	1	1	1	0
Z ₀	1	0	0	0	0	0	0	0	0	0	1
E _M	0	0	0	0	0	0	0	0	0	0	0
UP	→										
DOWN	←										

5EX

Pulse / Phase	0 (Reset)	1	2	3	4	5	6	7	8	9	10
ø A	1	1	0	0	0	0	0	1	1	1	1
ø B	1	1	1	0	0	0	0	0	1	1	1
ø C	1	1	1	1	0	0	0	0	0	1	1
ø D	1	1	1	1	1	0	0	0	0	0	1
ø E	0	1	1	1	1	1	0	0	0	0	0
ø \bar{A}	0	0	1	1	1	1	1	0	0	0	0
ø \bar{B}	0	0	0	1	1	1	1	1	0	0	0
ø \bar{C}	0	0	0	0	1	1	1	1	1	0	0
ø \bar{D}	0	0	0	0	0	1	1	1	1	1	0
ø \bar{E}	1	0	0	0	0	0	1	1	1	1	1
Z ₀	1	0	0	0	0	0	0	0	0	0	1
E _M	1	1	1	1	1	1	1	1	1	1	1
UP	→										
DOWN	←										

4-5EX

Pulse / Phase	0 (Reset)	1	2	3	4	5	6	7	8	9	10	11	12	13	14	15	16	17	18	19	20
ø A	1	1	0	0	0	0	0	0	0	0	0	0	0	1	1	1	1	1	1	1	1
ø B	1	1	1	1	0	0	0	0	0	0	0	0	0	0	1	1	1	1	1	1	1
ø C	1	1	1	1	1	1	0	0	0	0	0	0	0	0	0	0	0	1	1	1	1
ø D	1	1	1	1	1	1	1	1	0	0	0	0	0	0	0	0	0	0	0	1	1
ø E	0	1	1	1	1	1	1	1	1	1	0	0	0	0	0	0	0	0	0	0	0
ø \bar{A}	0	0	0	1	1	1	1	1	1	1	1	1	0	0	0	0	0	0	0	0	0
ø \bar{B}	0	0	0	0	0	1	1	1	1	1	1	1	1	1	0	0	0	0	0	0	0
ø \bar{C}	0	0	0	0	0	0	0	1	1	1	1	1	1	1	1	0	0	0	0	0	0
ø \bar{D}	0	0	0	0	0	0	0	0	0	1	1	1	1	1	1	1	1	1	0	0	0
ø \bar{E}	0	0	0	0	0	0	0	0	0	0	0	1	1	1	1	1	1	1	1	1	0
Z ₀	1	0	0	0	0	0	0	0	0	0	0	0	0	0	0	0	0	0	0	0	1
E _M	0	1	0	1	0	1	0	1	0	1	0	1	0	1	0	1	0	1	0	1	0
UP	→																				
DOWN	←																				

Input pulse monitor

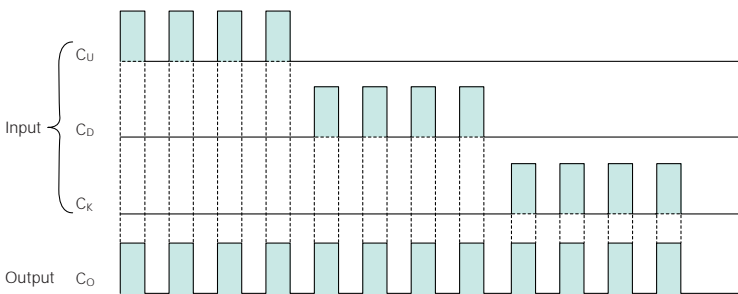

Example application circuit (full step/half step)

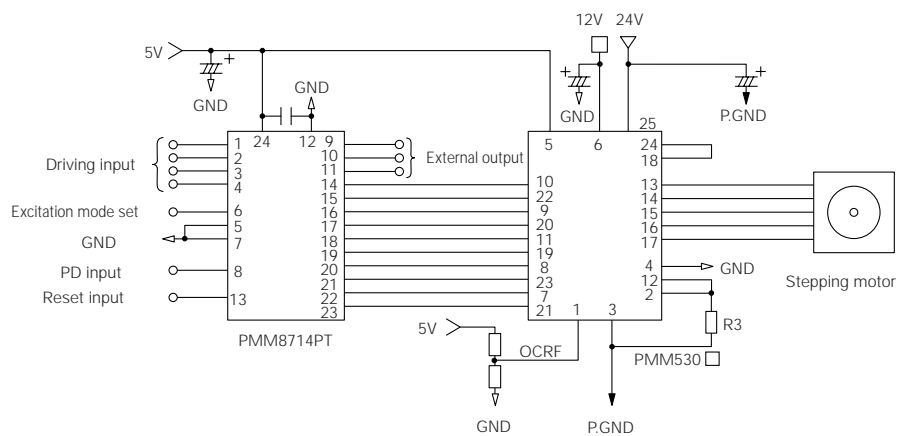

Excitation mode set

Pin No.	Terminal symbol	Input level	Motor operation
6	EB	H	Full step
		L	Half step

- When VCC is not stable, such as immediately after the power is on, normal initial reset can not always be performed. In order to perform firm reset, hold R terminal (13pin) at the "L" level until Vcc becomes stable.

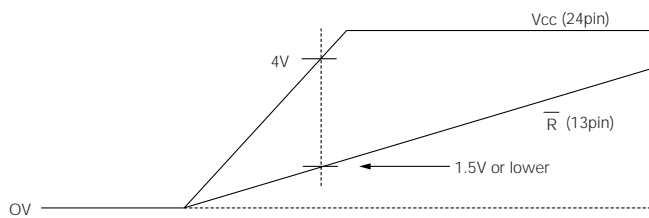

- Refer to Page 343 for the specifications of power hybrid IC:PMM530 □.
- Refer to Operation Manual of PMM8714PT for other applications.