



PN2907A

SMALL SIGNAL PNP TRANSISTOR

PRELIMINARY DATA

Ordering Code	Marking	Package / Shipment
PN2907A	PN2907A	TO-92 / Bulk
PN2907A-AP	PN2907A	TO-92 / Ammopack

- SILICON EPITAXIAL PLANAR PNP TRANSISTOR
- TO-92 PACKAGE SUITABLE FOR THROUGH-HOLE PCB ASSEMBLY
- THE NPN COMPLEMENTARY TYPE IS PN2222A

APPLICATIONS

- WELL SUITABLE FOR TV AND HOME APPLIANCE EQUIPMENT
- SMALL LOAD SWITCH TRANSISTOR WITH HIGH GAIN AND LOW SATURATION VOLTAGE

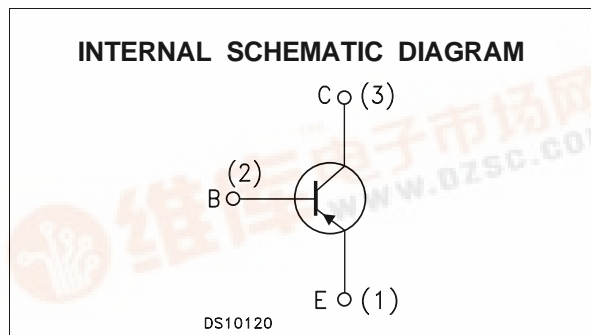
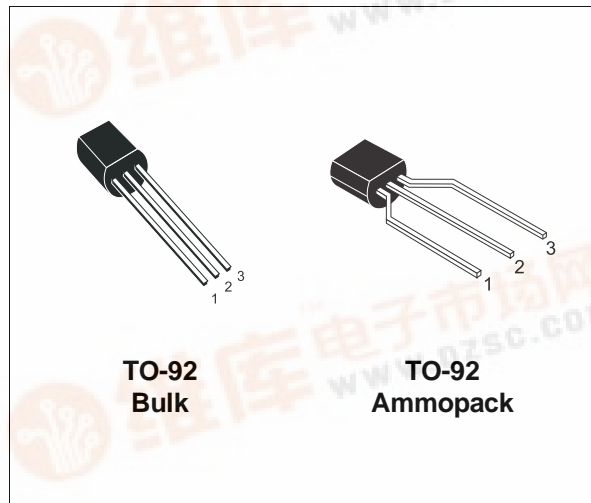

ABSOLUTE MAXIMUM RATINGS

Symbol	Parameter	Value	Unit
V_{CBO}	Collector-Emitter Voltage ($I_E = 0$)	-60	V
V_{CEO}	Collector-Emitter Voltage ($I_B = 0$)	-60	V
V_{EBO}	Emitter-Base Voltage ($I_C = 0$)	-5	V
I_C	Collector Current	-0.6	A
I_{CM}	Collector Peak Current ($t_p < 5$ ms)	-0.8	A
P_{tot}	Total Dissipation at $T_{amb} = 25$ °C	500	mW
T_{stg}	Storage Temperature	-65 to 150	°C
T_j	Max. Operating Junction Temperature	150	°C

PN2907A

THERMAL DATA

$R_{thj-amb}$	Thermal Resistance Junction-Ambient	Max	250	$^{\circ}\text{C}/\text{W}$
$R_{thj-case}$	Thermal Resistance Junction-Case	Max	83.3	$^{\circ}\text{C}/\text{W}$

ELECTRICAL CHARACTERISTICS ($T_{case} = 25^{\circ}\text{C}$ unless otherwise specified)

Symbol	Parameter	Test Conditions	Min.	Typ.	Max.	Unit
I_{CEX}	Collector Cut-off Current ($V_{BE} = -3\text{ V}$)	$V_{CE} = -30\text{ V}$			-50	nA
I_{BEX}	Base Cut-off Current ($V_{BE} = -3\text{ V}$)	$V_{CE} = -30\text{ V}$			-50	nA
I_{CBO}	Collector Cut-off Current ($I_E = 0$)	$V_{CB} = -50\text{ V}$			-10	nA
$V_{(BR)CEO}^*$	Collector-Emitter Breakdown Voltage ($I_B = 0$)	$I_C = -10\text{ mA}$	-60			V
$V_{(BR)CBO}$	Collector-Base Breakdown Voltage ($I_E = 0$)	$I_C = -10\text{ }\mu\text{A}$	-60			V
$V_{(BR)EBO}$	Emitter-Base Breakdown Voltage ($I_C = 0$)	$I_E = -10\text{ }\mu\text{A}$	-5			V
$V_{CE(sat)}^*$	Collector-Emitter Saturation Voltage	$I_C = -150\text{ mA}$ $I_B = -15\text{ mA}$ $I_C = -500\text{ mA}$ $I_B = -50\text{ mA}$			-0.4 -1.6	V V
$V_{BE(sat)}^*$	Collector-Base Saturation Voltage	$I_C = -150\text{ mA}$ $I_B = -15\text{ mA}$ $I_C = -500\text{ mA}$ $I_B = -50\text{ mA}$			-1.3 -2.6	V V
h_{FE}^*	DC Current Gain	$I_C = -0.1\text{ mA}$ $V_{CE} = -10\text{ V}$ $I_C = -1\text{ mA}$ $V_{CE} = -10\text{ V}$ $I_C = -10\text{ mA}$ $V_{CE} = -10\text{ V}$ $I_C = -150\text{ mA}$ $V_{CE} = -10\text{ V}$ $I_C = -500\text{ mA}$ $V_{CE} = -10\text{ V}$	75 100 100 100 50		300	
f_T	Transition Frequency	$I_C = -50\text{ mA}$ $V_{CE} = -20\text{ V}$ $f = 100\text{ MHz}$	200			MHz
C_{CBO}	Collector-Base Capacitance	$I_E = 0$ $V_{CB} = -10\text{ V}$ $f = 1\text{ MHz}$			8	pF
C_{EBO}	Emitter-Base Capacitance	$I_C = 0$ $V_{EB} = -2\text{ V}$ $f = 1\text{ MHz}$			30	pF
t_d	Delay Time	$I_C = -150\text{ mA}$ $I_B = -15\text{ mA}$ $V_{CC} = -30\text{ V}$			10	ns
t_r	Rise Time				40	ns
t_{on}	Switching On Time				45	ns
t_s	Storage Time	$I_C = -150\text{ mA}$ $I_{B1} = -I_{B2} = -15\text{ mA}$ $V_{CC} = -30\text{ V}$		190		ns
t_f	Fall Time				30	ns
t_{off}	Switching Off Time			220		ns

* Pulsed: Pulse duration = 300 μs , duty cycle $\leq 2\%$

TO-92 MECHANICAL DATA

DIM.	mm			inch		
	MIN.	TYP.	MAX.	MIN.	TYP.	MAX.
A	4.32		4.95	0.170		0.195
b	0.36		0.51	0.014		0.020
D	4.45		4.95	0.175		0.194
E	3.30		3.94	0.130		0.155
e	2.41		2.67	0.095		0.105
e1	1.14		1.40	0.045		0.055
L	12.70		15.49	0.500		0.609
R	2.16		2.41	0.085		0.094
S1	1.14		1.52	0.045		0.059
W	0.41		0.56	0.016		0.022
V	4 degree		6 degree	4 degree		6 degree

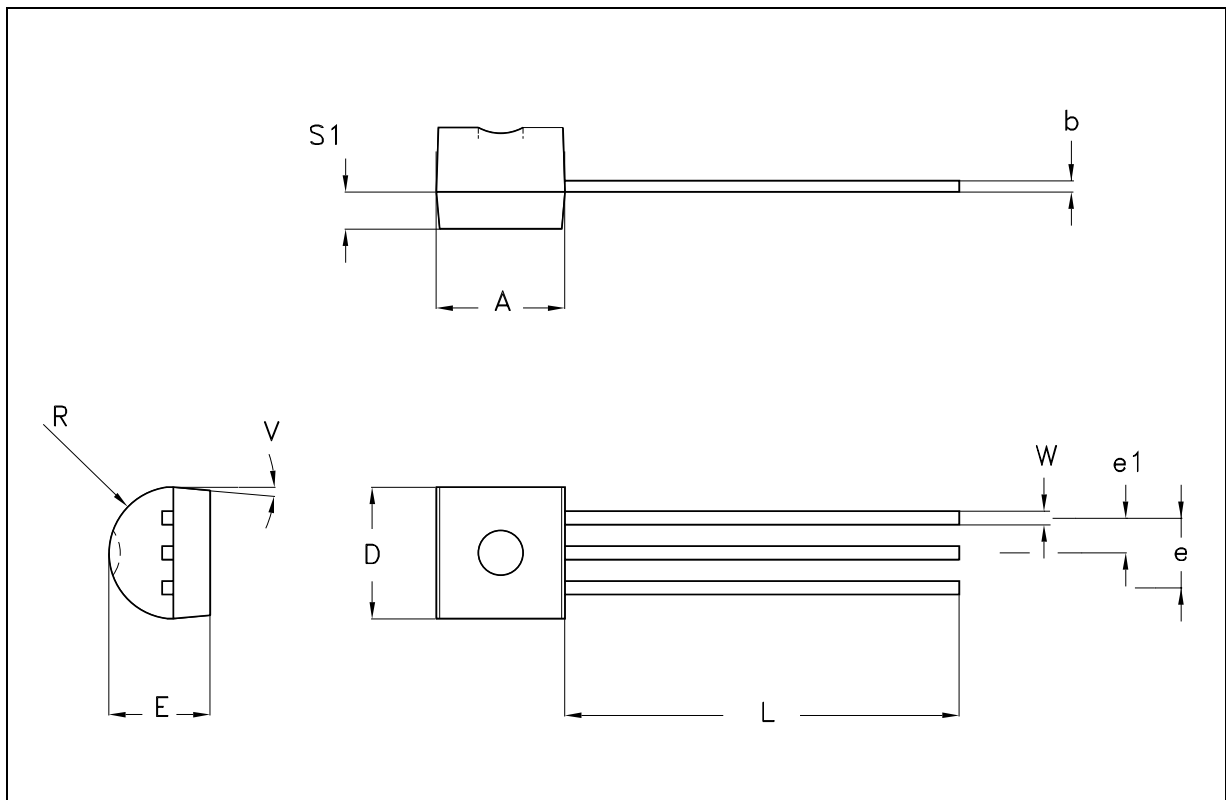

TO-92 AMMOPACK SHIPMENT (Suffix"-AP") MECHANICAL DATA

DIM.	mm			inch		
	MIN.	TYP.	MAX.	MIN.	TYP.	MAX.
A1			4.80			0.189
T			3.80			0.150
T1			1.60			0.063
T2			2.30			0.091
d			0.48			0.019
P0	12.50	12.70	12.90	0.492	0.500	0.508
P2	5.65	6.35	7.05	0.222	0.250	0.278
F1,F2	2.44	2.54	2.94	0.096	0.100	0.116
delta H	-2.00		2.00	-0.079		0.079
W	17.50	18.00	19.00	0.689	0.709	0.748
W0	5.70	6.00	6.30	0.224	0.236	0.248
W1	8.50	9.00	9.25	0.335	0.354	0.364
W2			0.50			0.020
H	18.50		20.50	0.728		0.807
H0	15.50	16.00	16.50	0.610	0.630	0.650
H1			25.00			0.984
D0	3.80	4.00	4.20	0.150	0.157	0.165
t			0.90			0.035
L			11.00			0.433
l1	3.00			0.118		
delta P	-1.00		1.00	-0.039		0.039

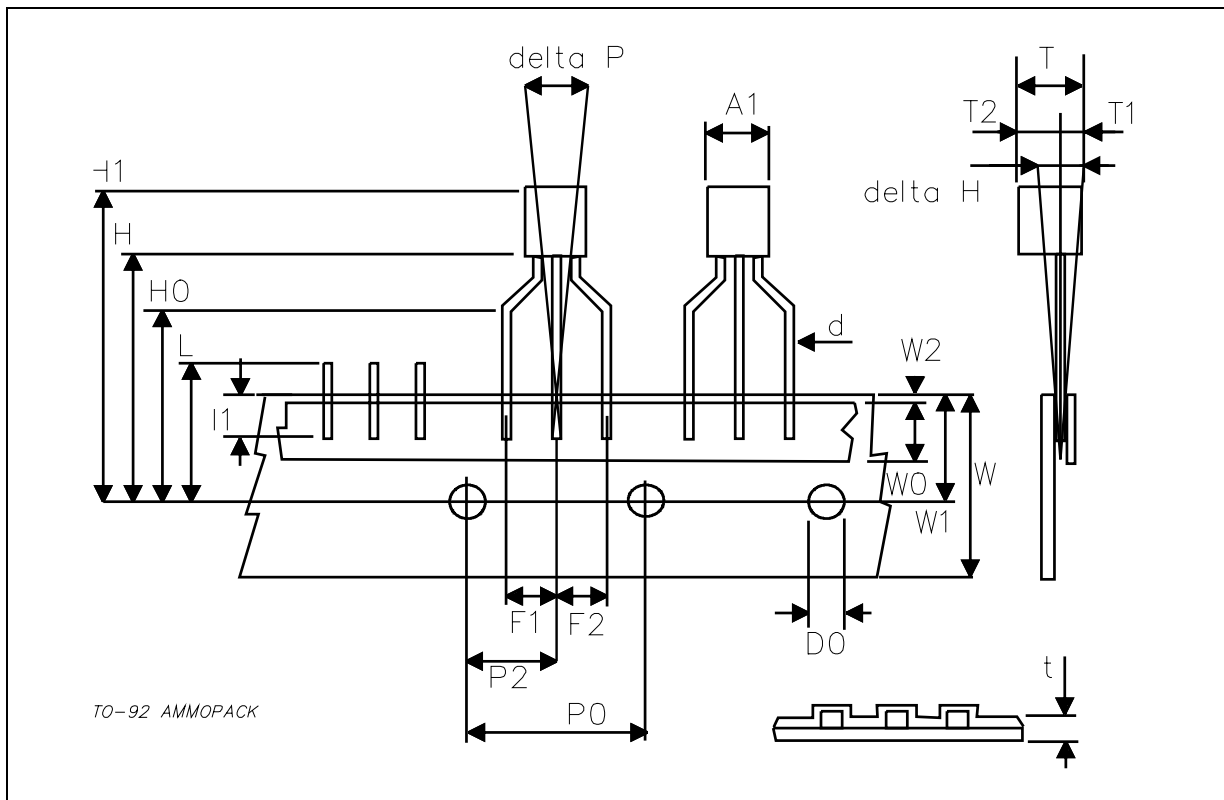

Information furnished is believed to be accurate and reliable. However, STMicroelectronics assumes no responsibility for the consequences of use of such information nor for any infringement of patents or other rights of third parties which may result from its use. No license is granted by implication or otherwise under any patent or patent rights of STMicroelectronics. Specification mentioned in this publication are subject to change without notice. This publication supersedes and replaces all information previously supplied. STMicroelectronics products are not authorized for use as critical components in life support devices or systems without express written approval of STMicroelectronics.

The ST logo is a trademark of STMicroelectronics

© 2003 STMicroelectronics – Printed in Italy – All Rights Reserved

STMicroelectronics GROUP OF COMPANIES

Australia - Brazil - Canada - China - Finland - France - Germany - Hong Kong - India - Israel - Italy - Japan - Malaysia - Malta - Morocco - Singapore - Spain - Sweden - Switzerland - United Kingdom - United States.

<http://www.st.com>