

PNA3602L

PIN Photodiode

For optical control systems

Features

- High quantum efficiency
- High-speed response
- Small size, thin side-view type package

Absolute Maximum Ratings (Ta = 25°C)

Parameter	Symbol	Ratings	Unit
Reverse voltage (DC)	V_R	30	V
Power dissipation	P_D	100	mW
Operating ambient temperature	T_{opr}	-25 to +85	°C
Storage temperature	T_{stg}	-30 to +100	°C

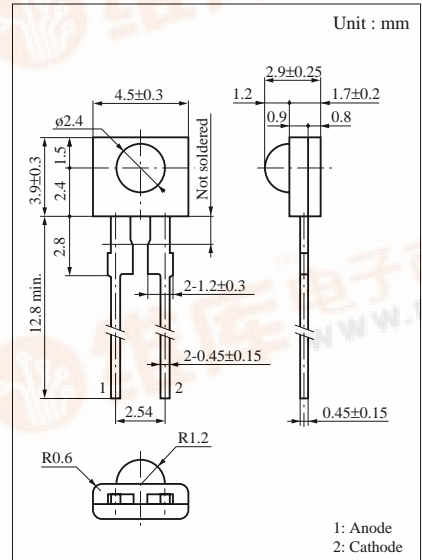

Electro-Optical Characteristics (Ta = 25°C)

Parameter	Symbol	Conditions	min	typ	max	Unit
Dark current	I_D	$V_R = 10V$		0.1	10	nA
Photo current	I_L	$V_R = 10V, L = 1000 \text{ lx}^{*1}$	16			μA
Peak sensitivity wavelength	λ_p	$V_R = 10V$		850		nm
Response time	t_r, t_f^{*2}	$V_R = 10V, R_L = 50\Omega$		2		ns
Capacitance between pins	C_t	$V_R = 10V, f = 1MHz$		6		pF
Acceptance half angle	θ	Measured from the optical axis to the half power point		45		deg.

*1 Measurements were made using a tungsten lamp (color temperature T = 2856K) as a light source.

*2 Switching time measurement circuit

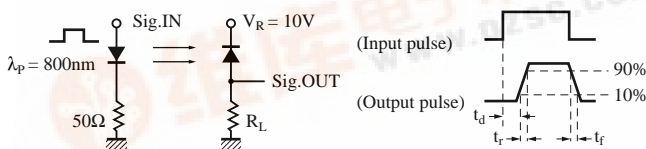

t_d : Delay time

t_r : Rise time (Time required for the collector photo current to increase from 10% to 90% of its final value)

t_f : Fall time (Time required for the collector photo current to decrease from 90% to 10% of its initial value)

$I_L - L$

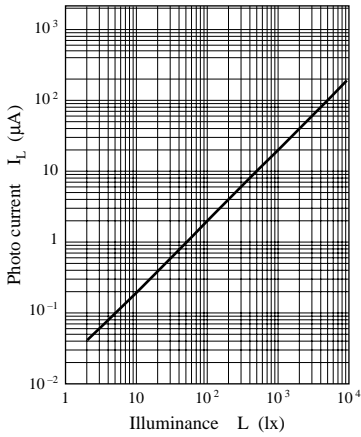

$I_D - T_a$

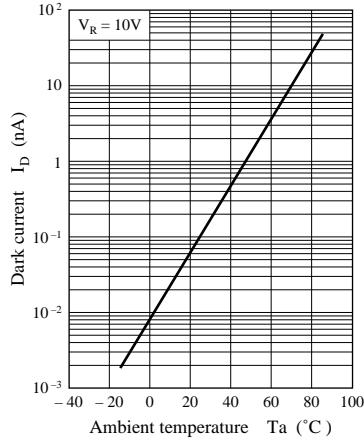

$I_L - T_a$

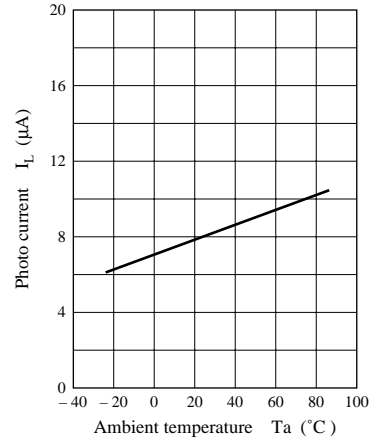

Spectral sensitivity characteristics

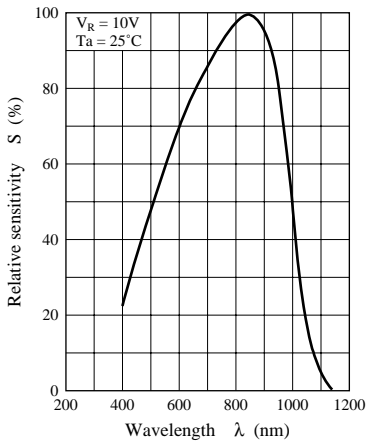

$t_r, t_f - R_L$

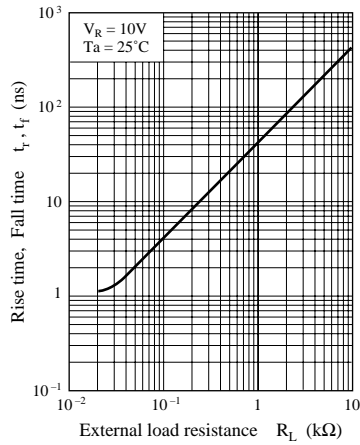

Directivity characteristics

