

# PNA4601M Series (PNA4601M/4602M/4608M/4610M)

## Bipolar Integrated Circuit with Photodetection Function

For infrared remote control systems

### ■ Features

- Extension distance is 8 m or more
- External parts not required
- Adoption of visible light cutoff resin

### ■ Absolute Maximum Ratings (Ta = 25°C)

Parameter	Symbol	Ratings	Unit
Power supply voltage	V <sub>CC</sub>	-0.5 to +7	V
Power dissipation	P <sub>D</sub>	200	mW
Operating ambient temperature	T <sub>opr</sub>	-20 to +75	°C
Storage temperature	T <sub>stg</sub>	-40 to +100	°C

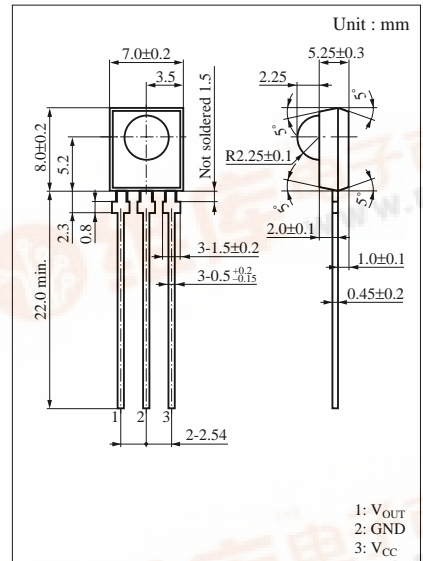

### ■ Main Characteristics (Ta = 25°C V<sub>CC</sub> = 5V)

Parameter	Symbol	Conditions	min	typ	max	Unit
Operating supply voltage	V <sub>CC</sub>		4.7	5.0	5.3	V
Current consumption	I <sub>CC</sub>	Note 3	1.8	2.4	3.0	mA
Maximum reception distance	L <sub>max</sub>	Note 1	8	10		m
Low-level output voltage	V <sub>OL</sub>	Note 2		0.35	0.5	V
High-level output voltage	V <sub>OH</sub>	Note 3	4.8	5.0	V <sub>CC</sub>	V
Low-level pulse width	T <sub>WL</sub>	Note 1	200	400	600	μs
High-level pulse width	T <sub>WH</sub>	Note 1	200	400	600	μs
Carrier frequency	PNA4601M	f <sub>0</sub>		36.7		kHz
	PNA4602M			38.0		
	PNA4608M			56.9		
	PNA4610M			33.3		

Note 1) Fig. 1 burst wave, L = L<sub>max</sub>, 16 pulses

Note 2) Fig. 2 continuous wave, L ≤ L<sub>max</sub>

Note 3) Light shut off condition

Carrier wave : f<sub>0</sub>

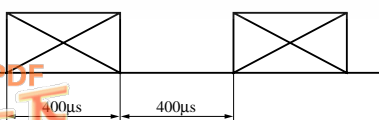

Fig.1

Carrier wave : f<sub>0</sub>



Fig.2



■ Block Diagram

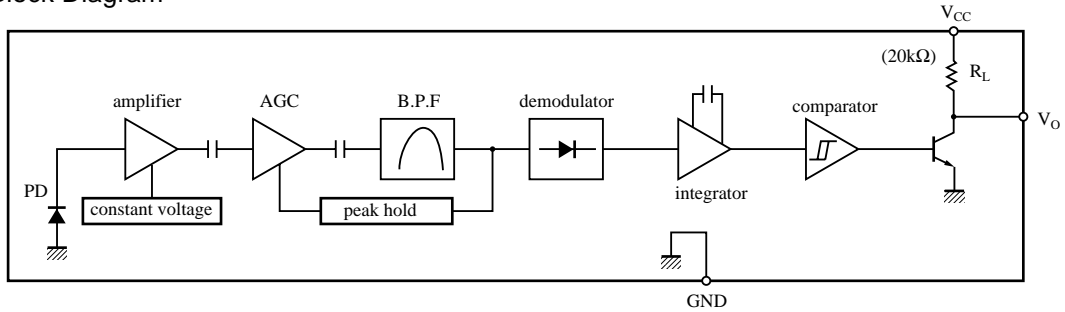

■ Panasonic Transmitter Specifications

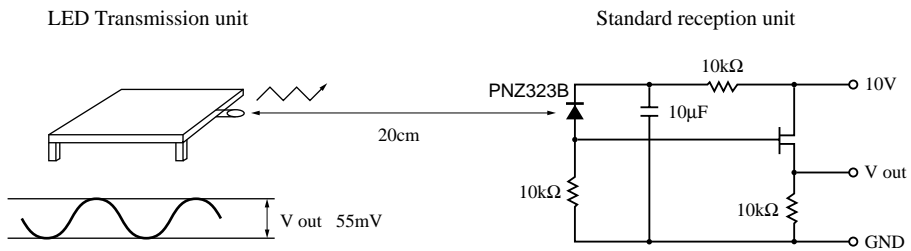

- The light output of the LED transmission unit is adjusted so that the transmission output ( $V_{out}$ ) of the standard reception unit will be 55 mV when the transmission waveform (duty = 50%) is output from the LED transmission unit. Here, infrared sensitivity (SIR) of PNZ323B is  $0.53 \mu A$  when emission illuminance (H) is  $12.45 \mu W/cm^2$ .
- The maximum reception distance under these specifications is an assurance that  $T_{WH}$  and  $T_{WL}$  values will be within the tolerance ranges when 16 consecutive pulses of an optical output equivalent to the maximum reception distance are transmitted by the above transmission unit (The maximum reception distance is measured in the dark without external disturbance noise.)

L max — Ta

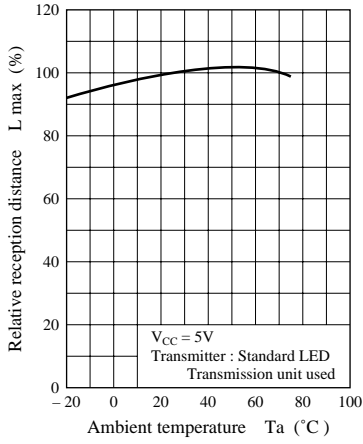

B.P.F frequency characteristics (PNA4602M)\*

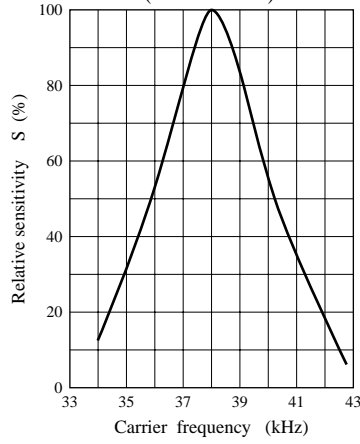

Spectral sensitivity characteristics

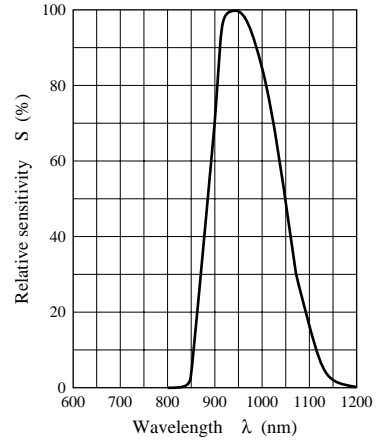

\* The peaks for PNA4601M, PNA4608M, and PNA4610M are all  $f_0$ .

Directivity characteristics

