



# PHOTO TRANSISTOR

## PS1192HA

查询PS1192HA供应商

通多邦, 专业PCB打样工厂, 24小时加急出货

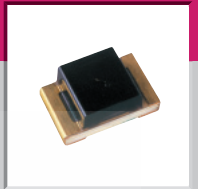

### Absolute Maximum Rating

Ta = 25°C

Part No.	Power Dissipation Pc	Collector-Emitter Voltage VCEo	Emitter-Collector Voltage VECo	Collector Current Ic	Operating Temperature Topr	Storage Temperature Tstg
PS1192HA	75	30	5	20	-30~+85	-30~+90
Units	mW	V	V	mA	°C	°C

### Electro-Optical Characteristics

Ta = 25°C

Part No.	Peak Wavelength $\lambda_p$ TYP	Photo Current Ic				Response Time tr/ta				Dark Current ICEo	
		MIN	TYP	VCE	Ee	TYP	VCE	Ic	RL	MAX	VCEo
PS1192HA	900	0.4	2.0	5	5	8 / 9	10	2	100	0.1	10
Units	nm	mA	mA	V	mW/cm <sup>2</sup>	$\mu$ s	V	mA	$\Omega$	$\mu$ A	V

### Package Dimensions

Unit : mm

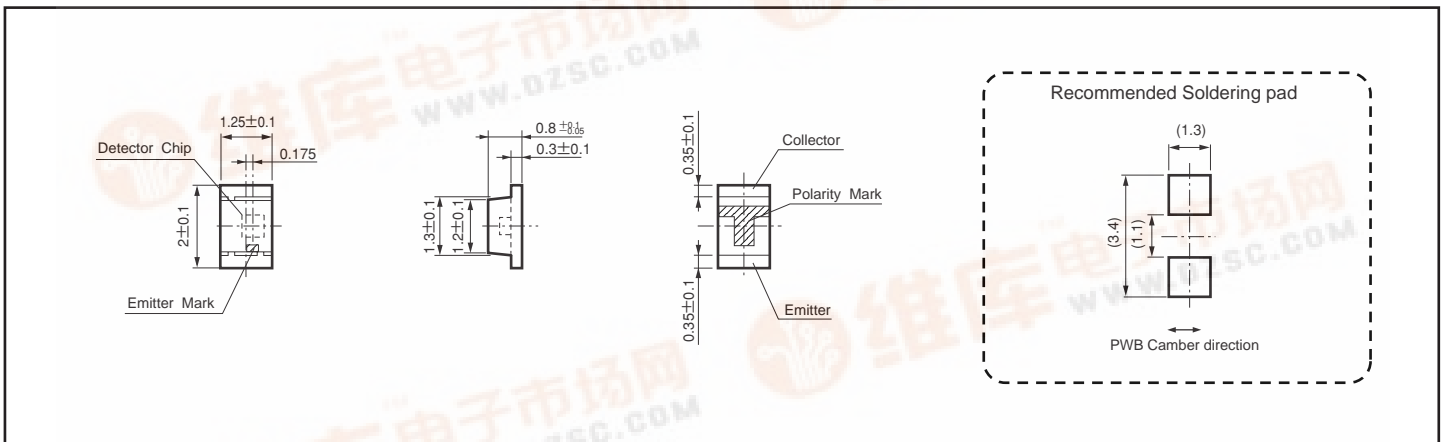

### Spatial Distribution

Ta = 25°C

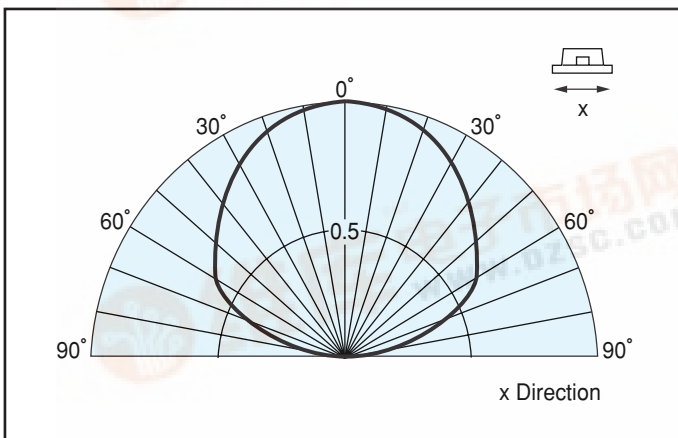

### Taping Specification

Unit : mm

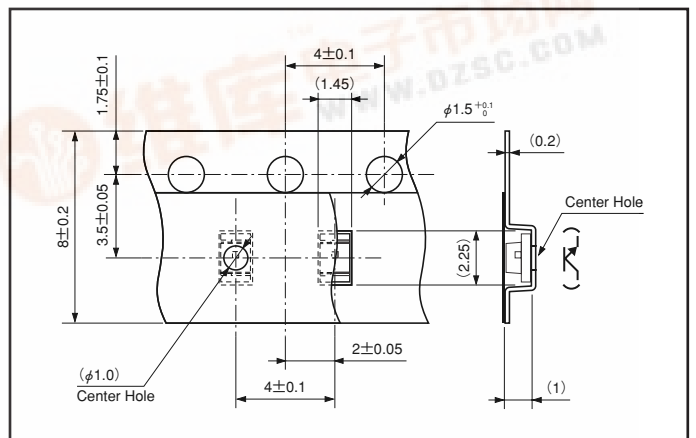

\* Quantity 4,000 pcs/Reel





# INFRARED LED

## PS1192HA

■ Radiant Illumination vs. Relative Photo Current

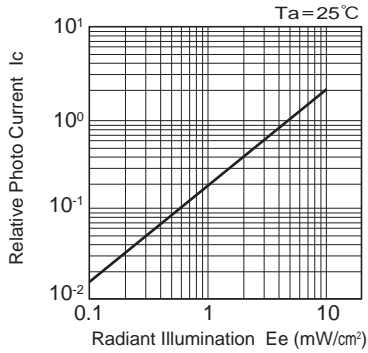

■ Collector Emitter Voltage vs. Photo Current

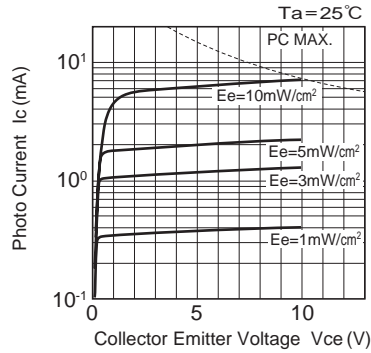

■ Ambient Temperature vs. Relative Photo Current

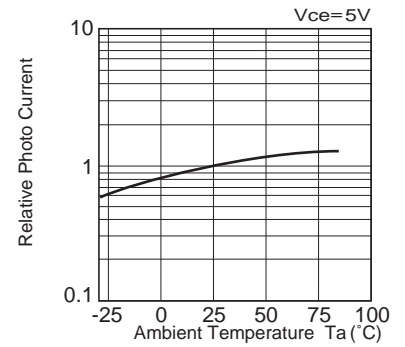

■ Ambient Temperature vs. Collector Dissipation

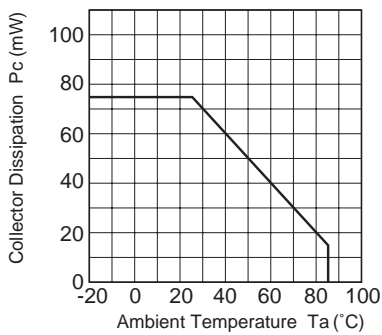

■ Ambient Temperature vs. Dark Current

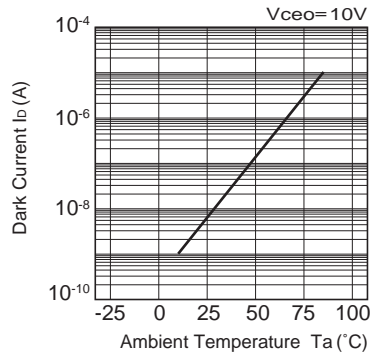

■ Spectral Sensitivity Characteristics

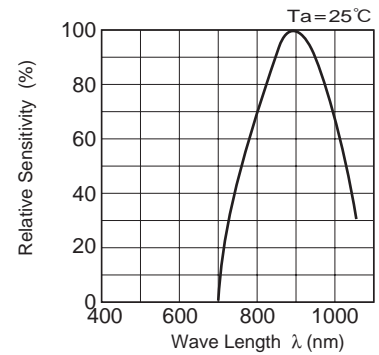

■ Response Time Measuring Circuit

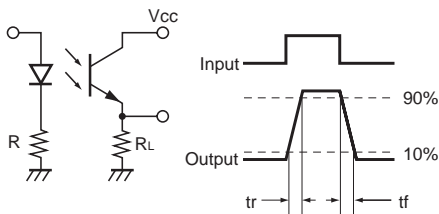

■ Response Time

