

**LOW INPUT CURRENT, HIGH SPEED SWITCHING**  
**MULTI PHOTOCOUPLER SERIES**

**DESCRIPTION**

PS2503-1, -2, -4 and PS2503L-1, -2, -4 series are optically coupled isolator containing a GaAs light emitting diode and an NPN silicon phototransistor.

PS2503-1, -2, -4 are in a plastic DIP (Dual In-line Package) and PS2503L-1, -2, -4 are lead bending type (Gull-wing) for surface mount.

**FEATURES**

- High isolation voltage (BV: 5 000 V<sub>r.m.s.</sub> MIN.)
- High speed switching ( $t_r = 20 \mu s$ ,  $t_f = 30 \mu s$  TYP., @ $R_L = 10 k\Omega$ )
- High current transfer ratio (CTR: 100 % MIN. @ $I_F = 1 mA$ ,  $V_{CE} = 5 V$ )
- Taping Product number (PS2503L-1-E3, E4, F3, F4)  
 (PS2503L-2-E3, E4)
- UL recognized [File No. E72422(S)]

**APPLICATIONS**

Interface circuit for various instrumentations, control equipments.

- AC Line/Digital Logic ..... Isolate high voltage transients
- Digital Logic/Digital Logic ..... Eliminate spurious ground loops
- Twisted pair line receiver ..... Eliminate ground look pick-up
- Telephone/Telegraph line receiver ..... Isolate high voltage transients
- High Frequency Power Supply Feedback Control ..... Maintain floating ground
- Relay Contact Monitor ..... Isolate floating grounds and transients
- Power Supply Monitor ..... Isolate transients and ground systems

**ABSOLUTE MAXIMUM RATINGS (T<sub>A</sub> = 25 °C)**

		(PS2503-1)	(PS2503-2, 4)	
		(PS2503L-1)	(PS2503L-2, 4)	
<b>Diode</b>				
Reverse Voltage	V <sub>R</sub>	6	6	V
Forward Current (DC)	I <sub>F</sub>	80	80	mA
Power Dissipation Derating	ΔP <sub>D</sub> /°C	1.5	1.2	mW/°C
Power Dissipation	P <sub>D</sub>	150	120	mW/Channel
Peak Forward Current (PW = 100 μs, Duty Cycle 1 %)	I <sub>F(Peak)</sub>	1	1	A
<b>Transistor</b>				
Collector to Emitter Voltage	V <sub>CEO</sub>	40	40	V
Emitter to Collector Voltage	V <sub>ECO</sub>	0.6	0.6	V
Collector Current	I <sub>C</sub>	30	30	mA
Power Dissipation Derating	ΔP <sub>C</sub> /°C	1.5	1.2	mW/°C
Power Dissipation	P <sub>C</sub>	150	120	mW/Channel
<b>Coupled</b>				
Isolation Voltage*1	BV	5 000	5 000	V <sub>r.m.s.</sub>
Storage Temperature	T <sub>stg</sub>	-55 to +150	-55 to +150	°C
Operating Temperature	T <sub>opt</sub>	-55 to +100	-55 to +100	°C
Lead Temperature (Soldering 10 s)	T <sub>sol</sub>	260	260	°C

\*1 AC voltage for 1 minute at T<sub>A</sub> = 25 °C, RH = 60 % between input and output.

**ELECTRICAL CHARACTERISTICS (T<sub>A</sub> = 25 °C)**

PARAMETER		SYMBOL	MIN.	TYP.	MAX.	UNIT	TEST CONDITIONS
Diode	Forward Voltage	V <sub>F</sub>		1.1	1.3	V	I <sub>F</sub> = 1 mA
	Reverse Current	I <sub>R</sub>			5	μA	V <sub>R</sub> = 5 V
	Junction Capacitance	C <sub>t</sub>		50		pF	V = 0, f = 1 MHz
Transistor	Collector to Emitter Dark Current	I <sub>CEO</sub>			100	nA	V <sub>CE</sub> = 40 V, I <sub>F</sub> = 0
Coupled	Current Transfer Ratio*2	CTR	100	200	400	%	I <sub>F</sub> = 1 mA, V <sub>CE</sub> = 5 V
	Collector Saturation Voltage	V <sub>CE(sat)</sub>			0.25	V	I <sub>F</sub> = 1 mA, I <sub>C</sub> = 0.2 mA
	Isolation Resistance	R <sub>1-2</sub>	10 <sup>11</sup>			Ω	V <sub>in-out</sub> = 1 kV
	Isolation Capacitance	C <sub>1-2</sub>		0.5		pF	V = 0, f = 1 MHz
	Rise Time*3	t <sub>r</sub>		20		μs	V <sub>CC</sub> = 5 V, I <sub>F</sub> = 1 mA, R <sub>L</sub> = 10 kΩ
Fall Time*3	t <sub>f</sub>		30		μs	V <sub>CC</sub> = 5 V, I <sub>F</sub> = 1 mA, R <sub>L</sub> = 10 kΩ	

\*2 CTR rank (only PS2503-1, PS2503L-1)

- K : 200 to 400
- L : 150 to 300
- M : 100 to 200

\*3 Test Circuit for Switching Time

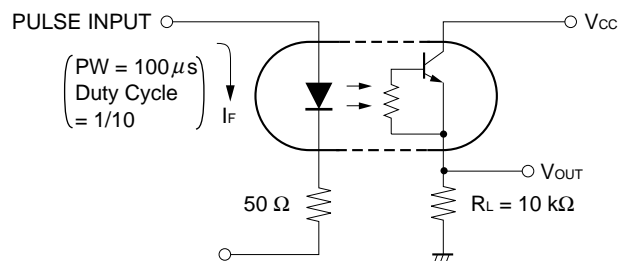

TYPICAL CHARACTERISTICS (T<sub>A</sub> = 25 °C)

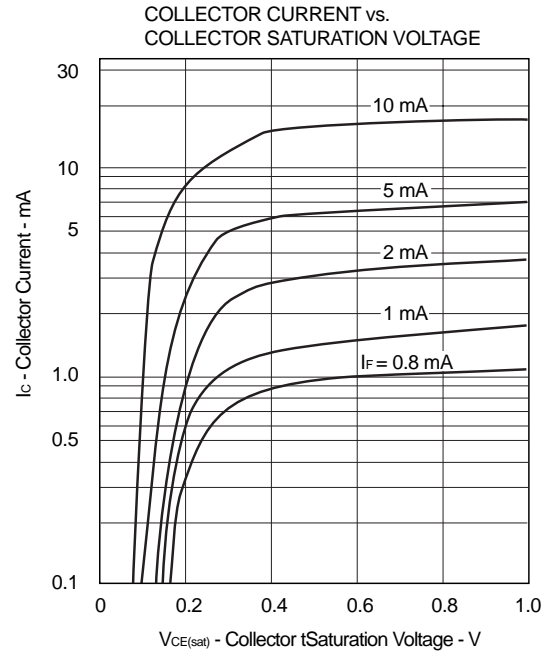
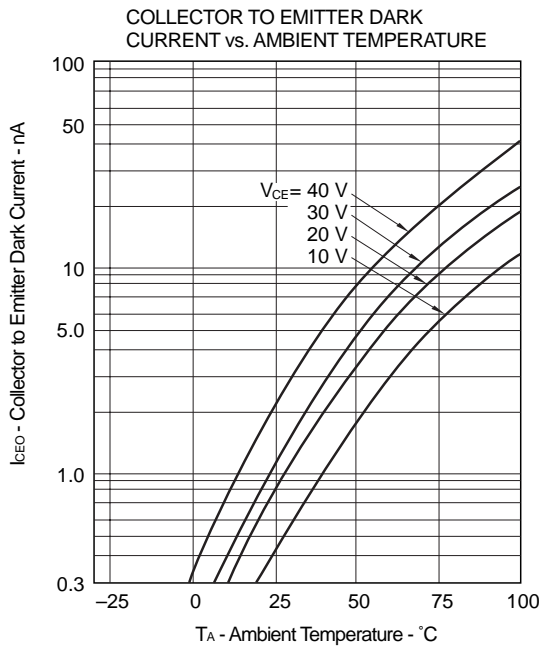
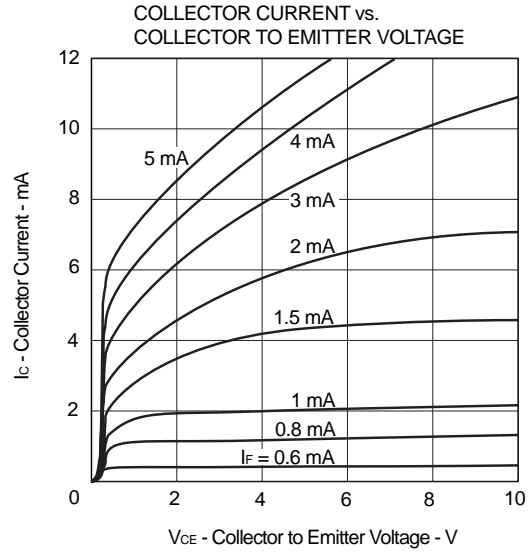
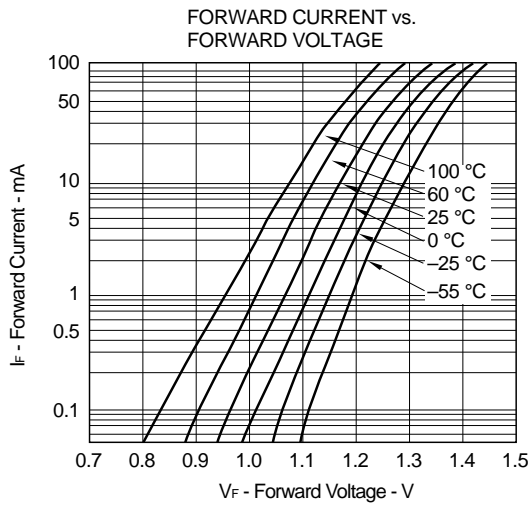
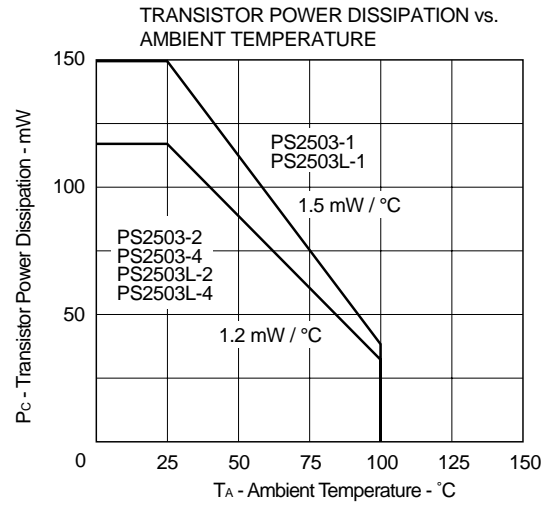
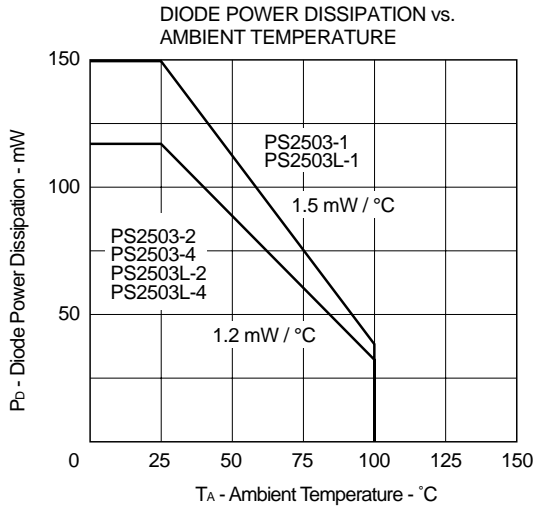

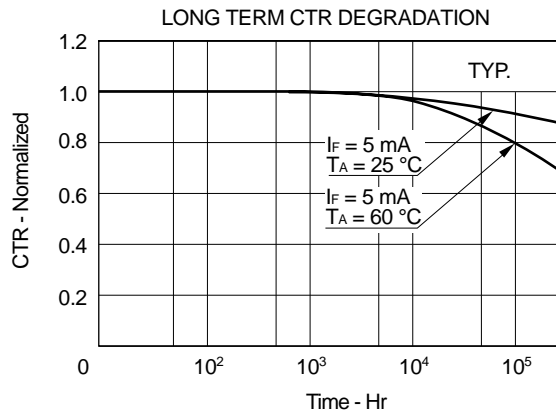
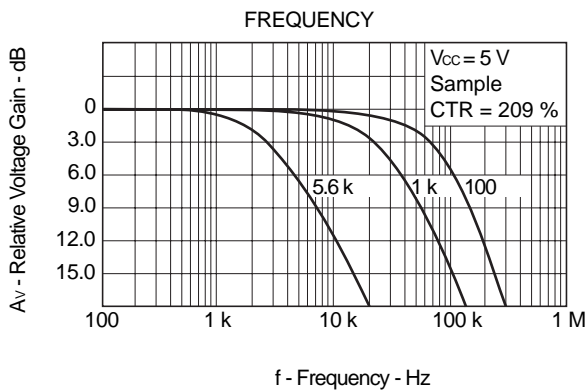
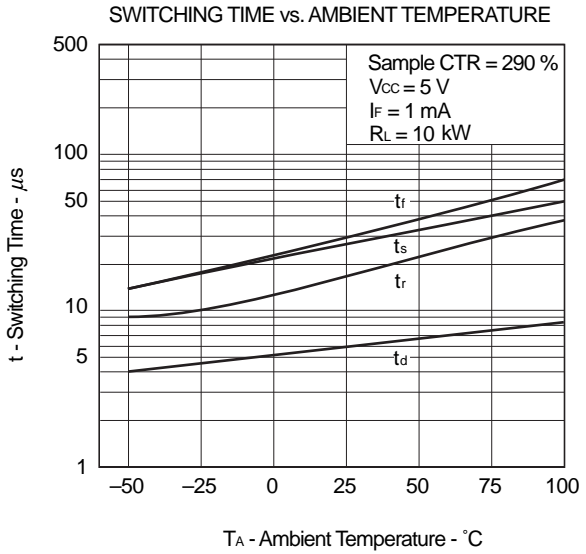
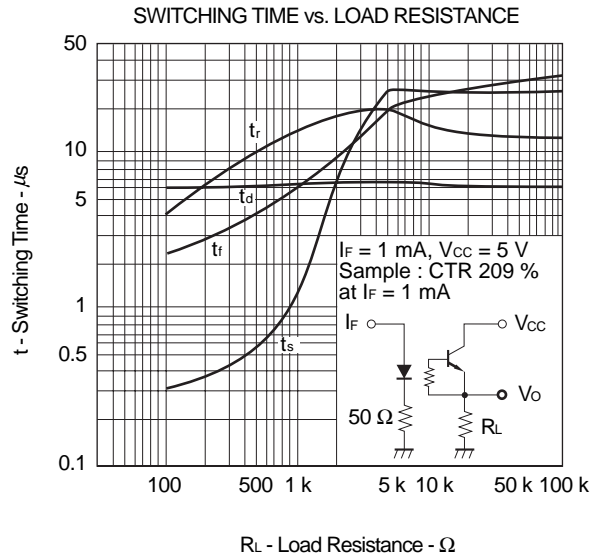
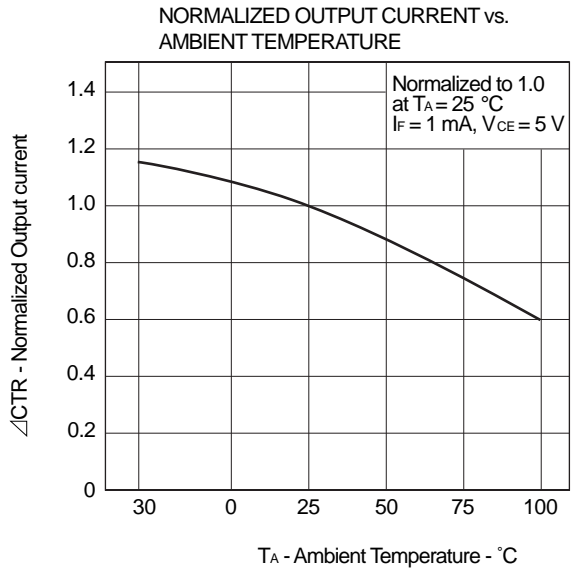
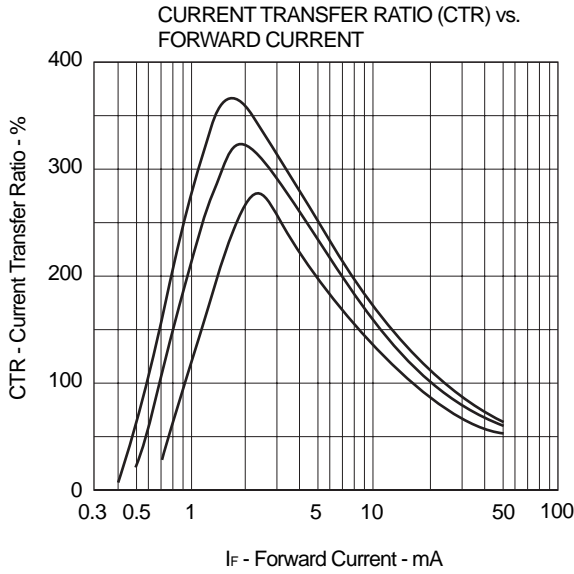

**SOLDERING PRECAUTION**

(1) Infrared reflow soldering

- Peak reflow temperature : 235 °C or below (Plastic surface temperature)
- Reflow time : 30 seconds or less (Time period during which the plastic surface temperature is 210 °C)
- Number of reflow processes : Three
- Flux : Rosin flux containing small amount of chlorine  
(The flux with a maximum chlorine content of 0.2 Wt % is recommended.)

**REFLOW TEMPERATURE PROFILE**

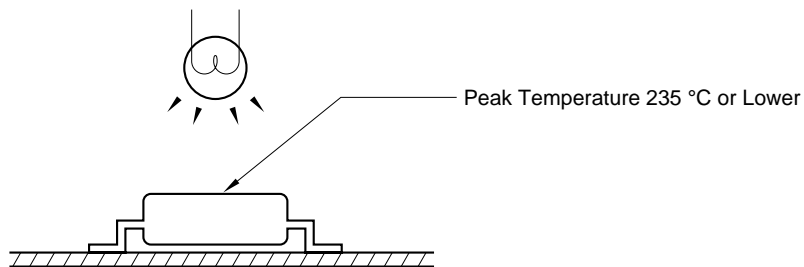
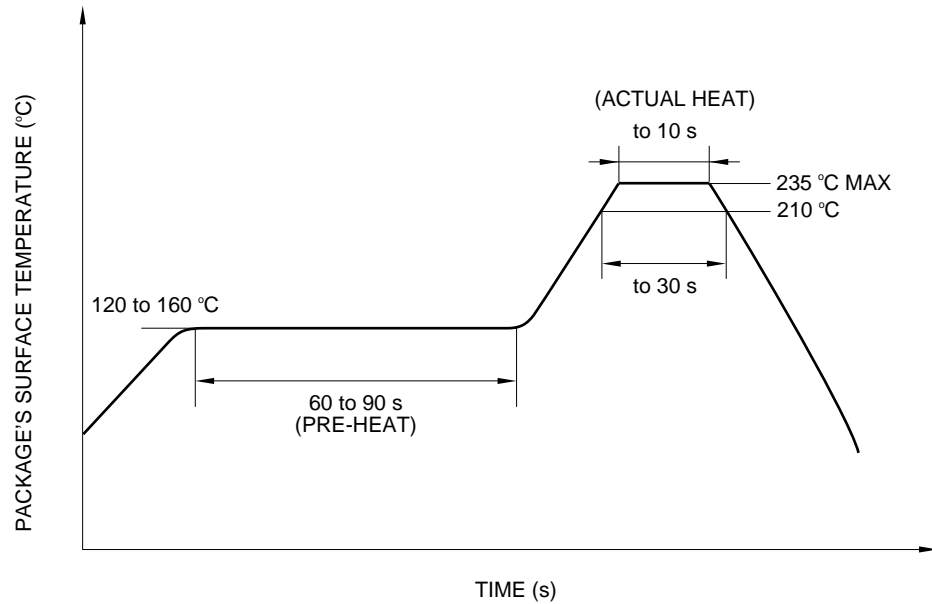

(2) Dip soldering

- Peak temperature : 260 °C or lower
- Time : 10 s or less
- Flux : Rosin-base flux

- 4 Pin DIP Type (Lead bending; -1 channel) Taping

1. TAPING DIRECTION

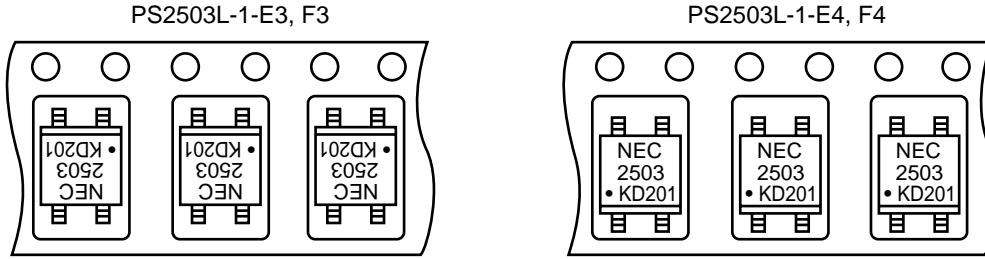

2. OUTLINE AND DIMENSIONS (;TAPE)

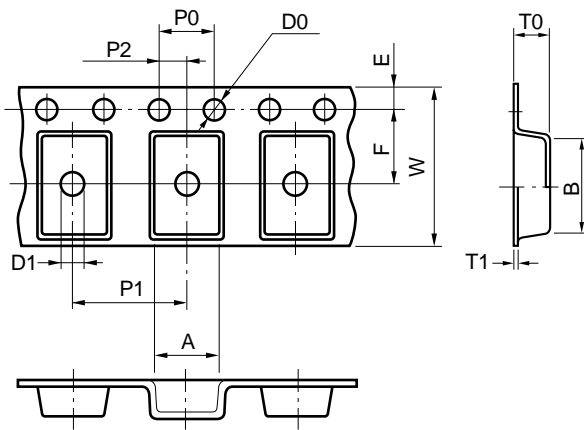

Unit: mm

SYMBOL	RATINGS
A	5.6 ± 0.1
B	10.3 ± 0.1
D0	1.55 ± 0.1
D1	1.55 ± 0.1
E	1.75 ± 0.1
F	7.5 ± 0.1
P1	8 ± 0.1
P0	4 ± 0.1
P2	2 ± 0.1
T0	4.3 ± 0.2
T1	0.3
W	16 ± 0.3

3. OUTLINE AND DIMENSIONS (;REEL)

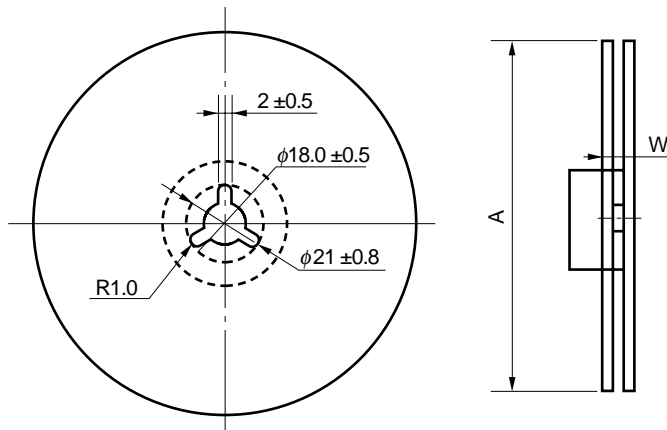

Unit: mm

SYMBOL	RATINGS	
A	E3, E4 250	F3, F4 330
N	80 ± 5.0	
W	16.4 <sup>+2.0</sup> <sub>-0</sub>	

4. PACKING

- E3, E4; 1000 pieces/reel
- F3, F4; 2000 pieces/reel

- 8 Pin DIP Type (Lead bending; -2 channel) Taping

1. TAPING DIRECTION

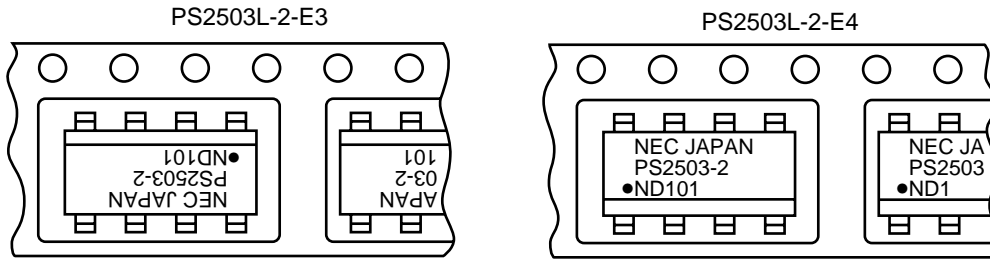

2. OUTLINE AND DIMENSIONS (;TAPE)

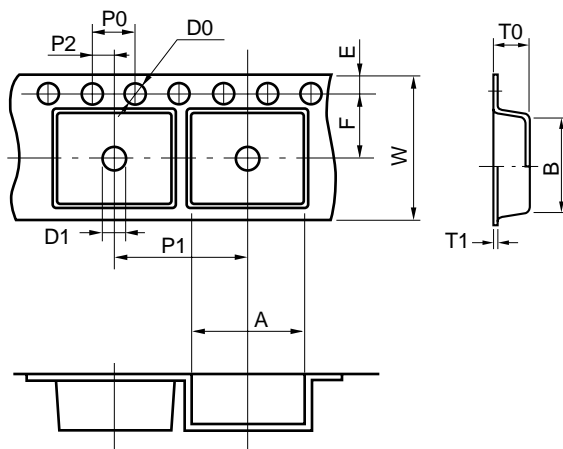

Unit: mm

SYMBOL	RATINGS
A	10.7 ± 0.1
B	10.3 ± 0.1
D0	1.55 ± 0.1
D1	1.55 ± 0.1
E	1.75 ± 0.1
F	7.5 ± 0.1
P0	4.0 ± 0.1
P1	12.0 ± 0.1
P2	2.0 ± 0.1
T0	4.3 ± 0.2
T1	0.3
W	16 ± 0.3

3. OUTLINE AND DIMENSIONS (;REEL)

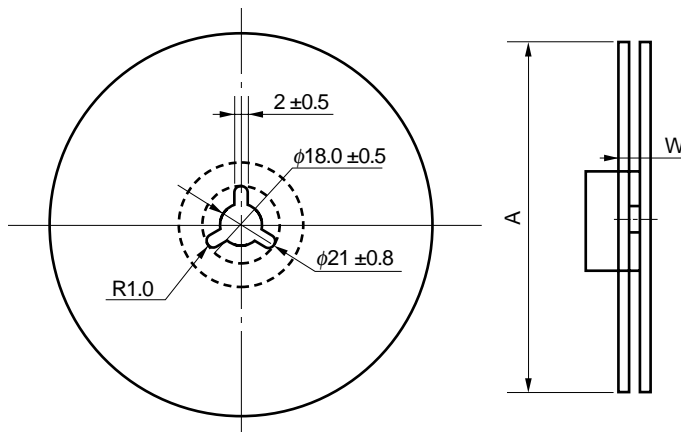

Unit: mm

SYMBOL	RATINGS
A	330
N	80 ± 5.0
W	16.4 <sup>+2.0</sup> <sub>-0</sub>

4. PACKING; 1000 pieces/reel

PACKAGE DIMENSIONS (Unit: mm) DIP (Dual In-line Package)

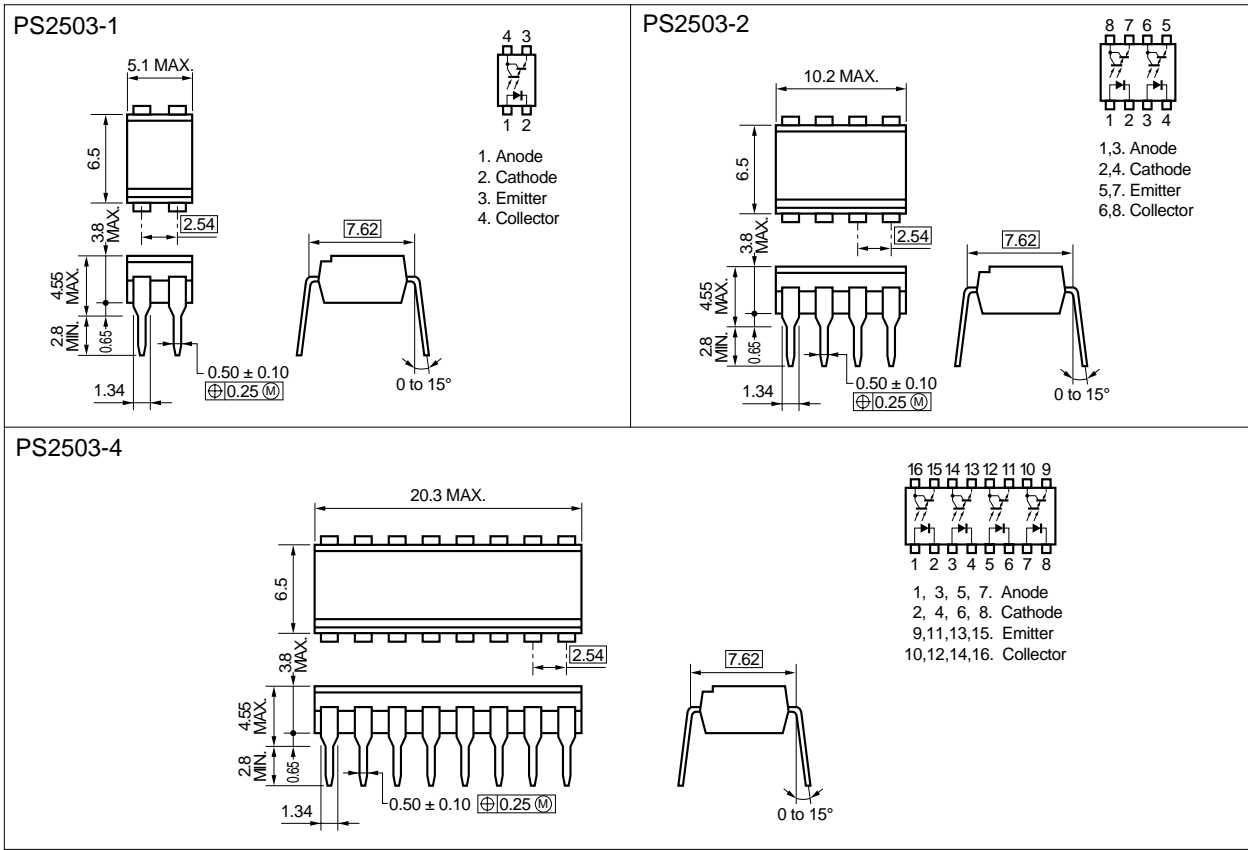

PACKAGE DIMENSIONS (Unit: mm) Lead Bending type (Gull-wing)

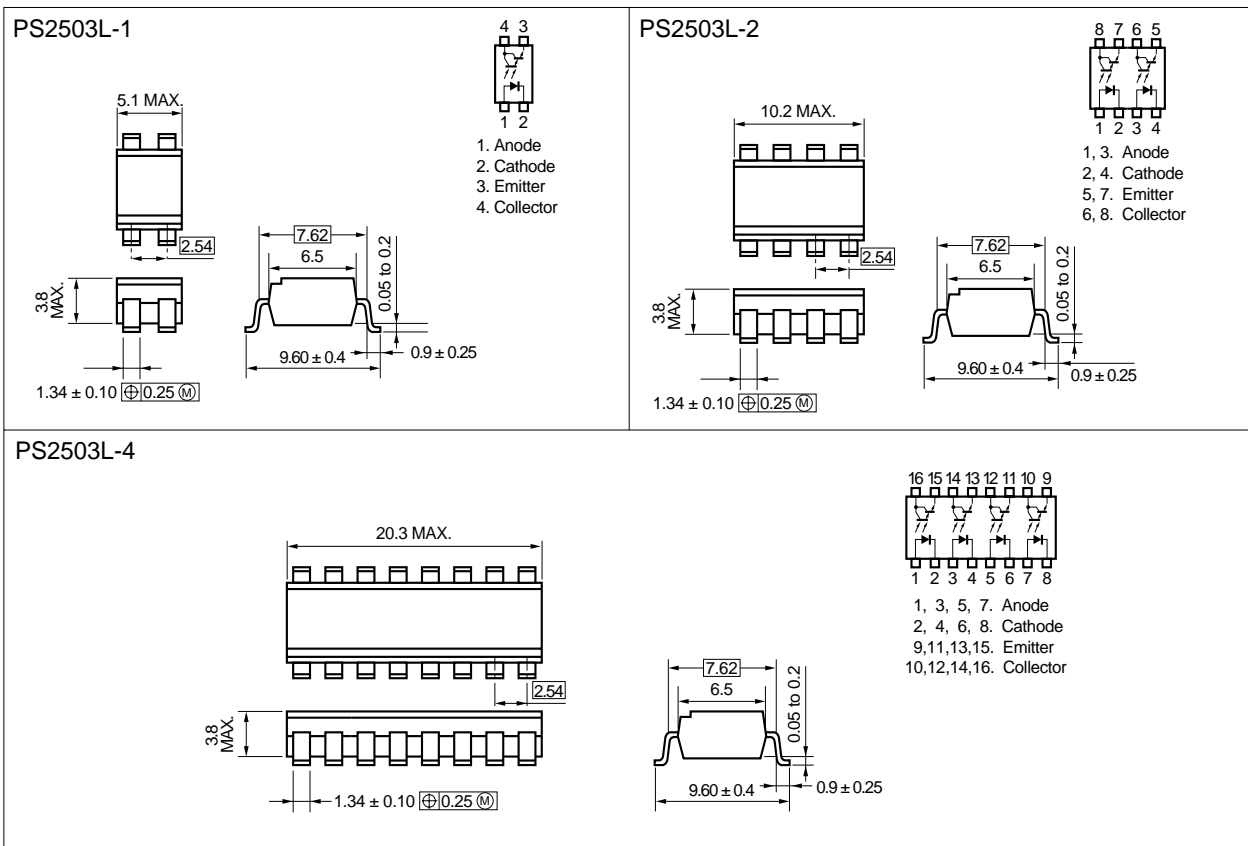



[MEMO]

## Caution

**The Great Care must be taken in dealing with the devices in this guide.  
The reason is that the material of the devices is GaAs (Galium Arsenide), which is  
designated as harmful substance according to the law concerned.  
Keep the law concerned and so on, especially in case of removal.**

No part of this document may be copied or reproduced in any form or by any means without the prior written consent of NEC Corporation. NEC Corporation assumes no responsibility for any errors which may appear in this document.

NEC Corporation does not assume any liability for infringement of patents, copyrights or other intellectual property rights of third parties by or arising from use of a device described herein or any other liability arising from use of such device. No license, either express, implied or otherwise, is granted under any patents, copyrights or other intellectual property rights of NEC Corporation or others.

While NEC Corporation has been making continuous effort to enhance the reliability of its semiconductor devices, the possibility of defects cannot be eliminated entirely. To minimize risks of damage or injury to persons or property arising from a defect in an NEC semiconductor device, customer must incorporate sufficient safety measures in its design, such as redundancy, fire-containment, and anti-failure features.

NEC devices are classified into the following three quality grades:

“Standard”, “Special”, and “Specific”. The Specific quality grade applies only to devices developed based on a customer designated “quality assurance program” for a specific application. The recommended applications of a device depend on its quality grade, as indicated below. Customers must check the quality grade of each device before using it in a particular application.

Standard: Computers, office equipment, communications equipment, test and measurement equipment, audio and visual equipment, home electronic appliances, machine tools, personal electronic equipment and industrial robots

Special: Transportation equipment (automobiles, trains, ships, etc.), traffic control systems, anti-disaster systems, anti-crime systems, safety equipment and medical equipment (not specifically designed for life support)

Specific: Aircrafts, aerospace equipment, submersible repeaters, nuclear reactor control systems, life support systems or medical equipment for life support, etc.

The quality grade of NEC devices in “Standard” unless otherwise specified in NEC's Data Sheets or Data Books. If customers intend to use NEC devices for applications other than those specified for Standard quality grade, they should contact NEC Sales Representative in advance.

Anti-radioactive design is not implemented in this product.