



# HIGH ISOLATION VOLTAGE DARLINGTON TRANSISTOR TYPE 6 PIN OPTOCOUPLER

PS2603  
PS2603L  
PS2604  
PS2604L

## FEATURES

- **HIGH ISOLATION VOLTAGE**  
BV: 5 k Vr.m.s. MIN
- **HIGH SPEED SWITCHING**  
 $t_r, t_f = 100 \mu\text{s}$  TYP
- **ULTRA HIGH CURRENT TRANSFER RATIO**  
CTR: 300% TYP

## DESCRIPTION

PS2603, PS2604, PS2603L and PS2604L are optically coupled isolators containing a GaAs light emitting diode and an NPN silicon Darlington-connected phototransistor. PS2603 and PS2604 are in a plastic DIP (Dual In-line Package). PS2603L and PS2604L are lead bending type (Gull-wing) for surface mount. PS2603 and PS2603L have a base pin, PS2604 and PS2604L have no base pin.

## APPLICATIONS

Interface circuit for various instrumentations and control equipment.

- **AC LINE / DIGITAL LOGIC**
- **DIGITAL LOGIC / DIGITAL LOGIC**
- **TWISTED PAIR LINE RECEIVER**
- **TELEPHONE / TELEGRAPH LINE RECEIVER**
- **HIGH FREQUENCY POWER SUPPLY FEEDBACK CONTROL**

## ELECTRICAL CHARACTERISTICS (TA = 25°C)

PART NUMBER			PS2603, PS2603L, PS2604, PS2604L		
SYMBOLS	PARAMETERS	UNITS	MIN	TYP	MAX
Diode	V <sub>F</sub>	Forward Voltage, I <sub>F</sub> = 10 mA		1.1	1.4
	I <sub>R</sub>	Reverse Current, V <sub>R</sub> = 5 V			5
	C	Junction Capacitance, V = 0, f = 1.0 MHz		30	
Transistor	I <sub>CEO</sub>	Collector to Emitter Dark Current, V <sub>CE</sub> = 40 V, I <sub>F</sub> = 0			400
	BV <sub>CEO</sub>	Collector to Emitter Breakdown Voltage, I <sub>C</sub> = 1 mA, I <sub>B</sub> = 0	40		
	BV <sub>ECO</sub>	Emitter to Collector Breakdown Voltage, I <sub>E</sub> = 100 μA, I <sub>B</sub> = 0	6		
Coupled	CTR	Current Transfer Ratio <sup>1</sup> , I <sub>F</sub> = 1 mA, V <sub>CE</sub> = 2 V	200	2000	
	V <sub>CE(sat)</sub>	Collector Saturation Voltage, I <sub>F</sub> = 1 mA, I <sub>C</sub> = 2 mA			1.0
	R <sub>1-2</sub>	Isolation Resistance, V <sub>IN-OUT</sub> = 1.0 k V	10 <sup>11</sup>		
	C <sub>1-2</sub>	Isolation Capacitance, V = 0, f = 1.0 MHz		0.6	
	t <sub>r</sub>	Rise Time <sup>2</sup> , V <sub>CC</sub> = 10 V, I <sub>C</sub> = 10 mA		100	
t <sub>f</sub>	Fall Time <sup>2</sup> , V <sub>CC</sub> = 10 V, I <sub>C</sub> = 10 mA		100		

Notes:

- CTR Rank  
KD : 2000 to %  
LD : 700 to 3400 %  
MD : 200 to 1000 %

2. Test Circuit for Switching Time

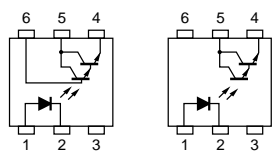

PS2603

PS2604

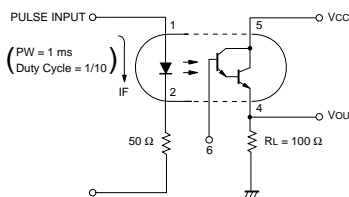

PS2603

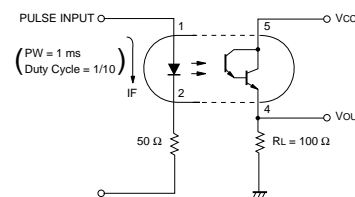

PS2604

**ABSOLUTE MAXIMUM RATINGS<sup>1</sup>** (T<sub>A</sub> = 25°C)

SYMBOLS	PARAMETERS	UNITS	RATINGS
<b>Diode</b>			
V <sub>R</sub>	Reverse Voltage	V	6
I <sub>F</sub>	Forward Current (DC)	mA	80
P <sub>D</sub>	Power Dissipation	mW	150
I <sub>F</sub> (PEAK)	Peak Forward Current (PW = 100 μs, Duty Cycle 1%)	A	1
<b>Transistor</b>			
V <sub>CEO</sub>	Collector to Emitter Voltage	V	40
V <sub>ECO</sub>	Emitter to Collector Voltage	V	6
I <sub>C</sub>	Collector Current	mA	200
P <sub>C</sub>	Power Dissipation	mW	200
<b>Coupled</b>			
BV	Isolation Voltage <sup>2</sup>	V <sub>r.m.s.</sub>	5000
T <sub>STG</sub>	Storage Temperature	°C	-55 to +150
T <sub>OP</sub>	Operating Temperature	°C	-55 to +100

Notes

1. Operation in excess of any one of these parameters may result in permanent damage.
2. AC voltage for 1 minute at T<sub>A</sub> = 25° C, RH = 60% between input (Pin No. 1, 2, 3 Common) and output (Pin No. 4, 5, 6 Common).

**TYPICAL PERFORMANCE CURVES** (T<sub>A</sub> = 25°)

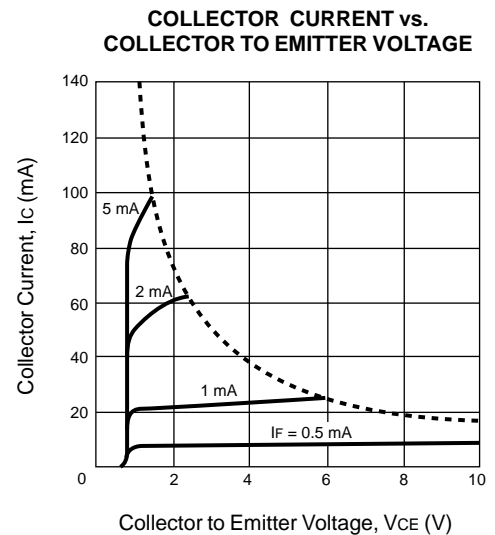
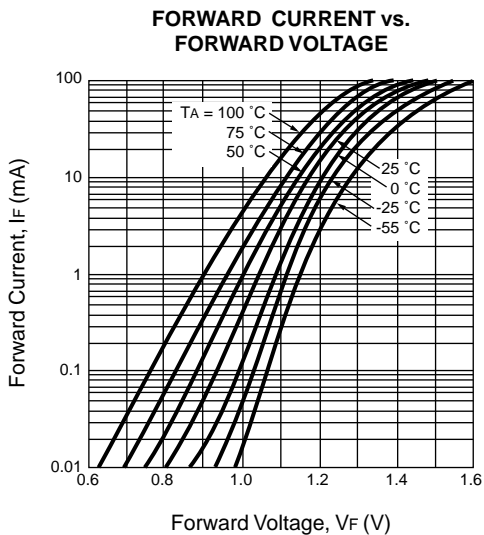
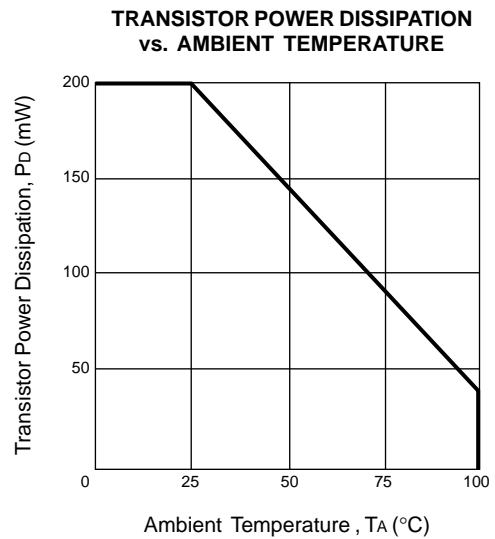
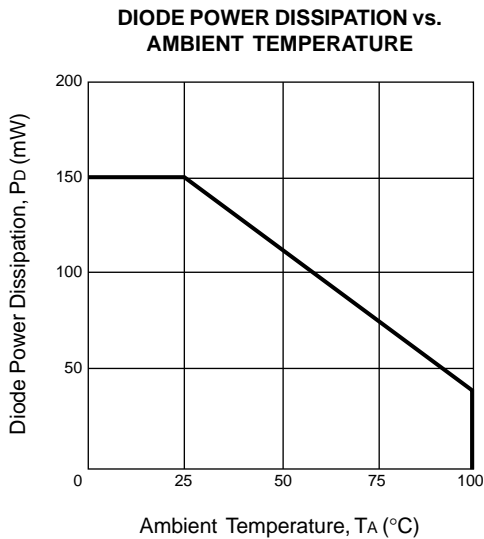

**TYPICAL PERFORMANCE CURVES** ( $T_A = 25^\circ$ )

**COLLECTOR TO EMITTER DARK CURRENT vs. AMBIENT TEMPERATURE**

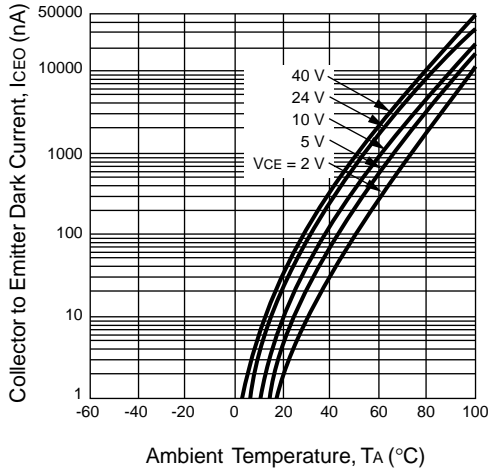

**COLLECTOR CURRENT vs. COLLECTOR SATURATION VOLTAGE**

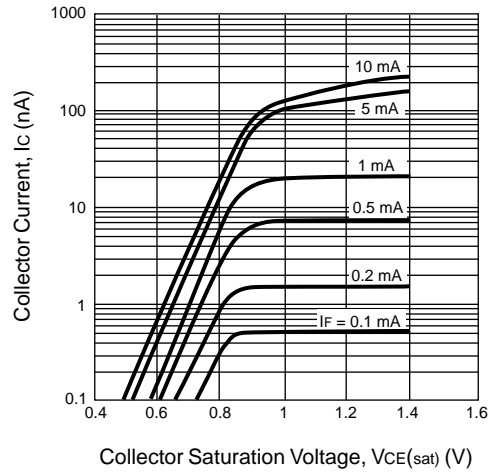

**NORMALIZED OUTPUT CURRENT vs. AMBIENT TEMPERATURE**

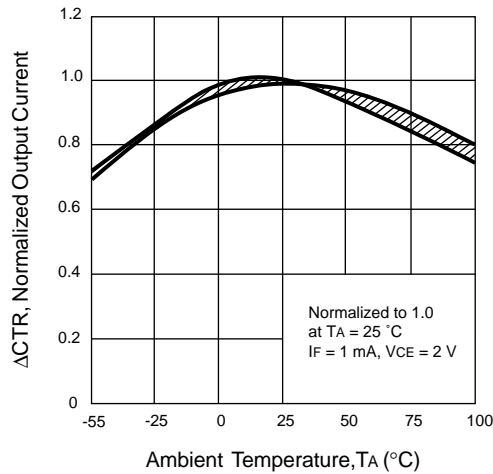

**CURRENT TRANSFER RATIO (CTR) vs. FORWARD CURRENT**

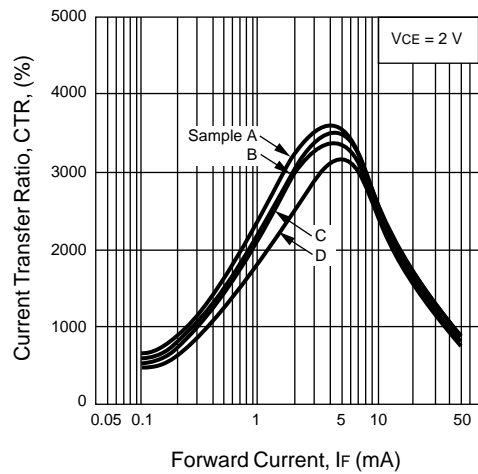

**SWITCHING TIME vs. LOAD RESISTANCE**

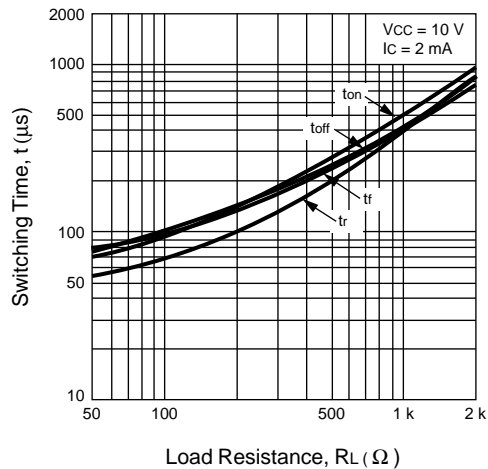

**FREQUENCY RESPONSE**

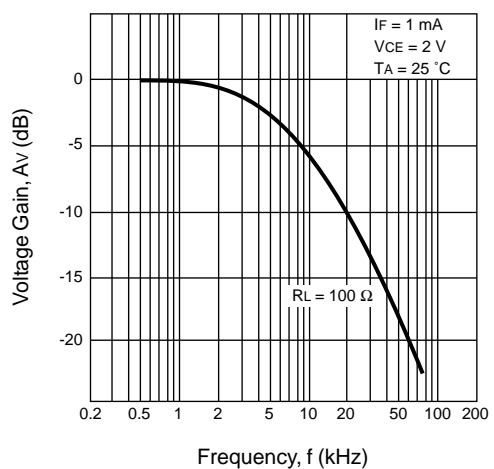

**TYPICAL PERFORMANCE CURVES** ( $T_A = 25^\circ$ )

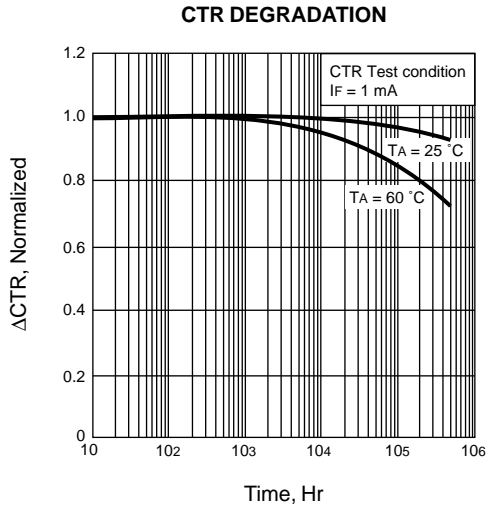

**OUTLINE DIMENSIONS** (Units in mm)

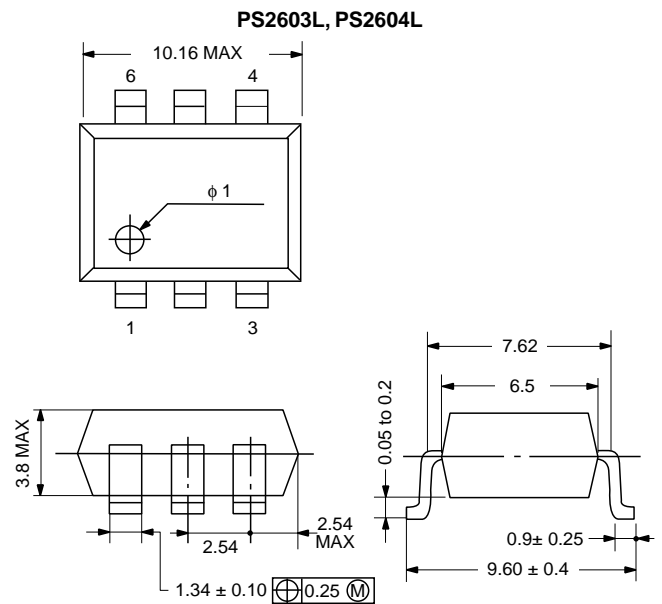
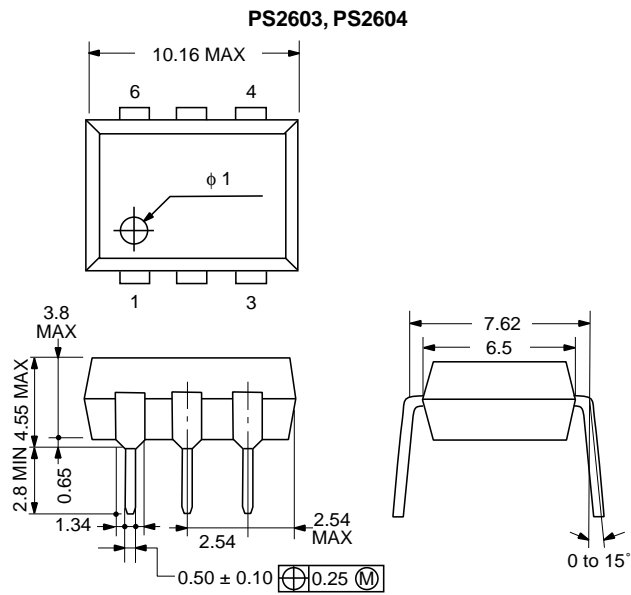

**PIN CONNECTIONS** (Top View)

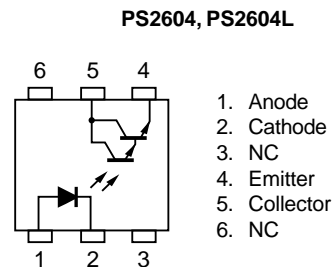
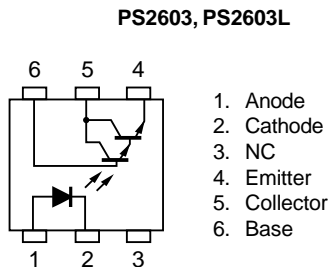

EXCLUSIVE NORTH AMERICAN AGENT FOR **NEC** RF, MICROWAVE & OPTOELECTRONIC SEMICONDUCTORS

**CEL CALIFORNIA EASTERN LABORATORIES** • Headquarters • 4590 Patrick Henry Drive • Santa Clara, CA 95054-1817 • (408) 988-3500 • Telex 34-6393 • FAX (408) 988-0279  
 24-Hour Fax-On-Demand: 800-390-3232 (U.S. and Canada only) • Internet: <http://WWW.CEL.COM>

DATA SUBJECT TO CHANGE WITHOUT NOTICE

PRINTED IN USA ON RECYCLED PAPER -3/98

Copyright © Each Manufacturing Company.

All Datasheets cannot be modified without permission.

This datasheet has been download from :

[www.AllDataSheet.com](http://www.AllDataSheet.com)

100% Free DataSheet Search Site.

Free Download.

No Register.

Fast Search System.

[www.AllDataSheet.com](http://www.AllDataSheet.com)