

4 PIN SOP LOW OUTPUT CAPACITANCE SOLID STATE RELAY

PS7200J-1A

FEATURES

- **1 CHANNEL TYPE**
1A output
- **LOW C X R**
 $C \times R = 15 \text{ pF} \cdot \Omega$
- **LOW OUTPUT CAPACITANCE**
 $C_{OUT} = 1.7 \text{ pF TYP}$
- **LOW OFF-STATE LEAKAGE CURRENT**
 $I_{LOFF} = 0.02 \text{ nA TYP}$
- **HIGH SPEED TURN-ON TIME**
 $t_{ON} = 8 \mu\text{s TYP}$
- **DESIGNED FOR AC/DC SWITCHING LINE CHANGER**
- **SMALL PACKAGE**
4 pin SOP
- **HIGH ISOLATION VOLTAGE**
 $BV = 1500 \text{ Vr.m.s.}$
- **LOW OFFSET VOLTAGE**
- **AVAILABLE IN TAPE AND REEL**
PS7200J-1A-E3, E4, F3, F4

DESCRIPTION

The PS7200J-1A is a low output capacitance solid state relay containing a GaAs LED on the light emitting side (input side) and MOSFETs on the output side.

It is suitable for high-frequency signal control, due to its low C x R and low output capacitance. This device is not recommended for new designs. It has been replaced by the PS7200R.

APPLICATIONS

- MEASUREMENT EQUIPMENT
- HIGH SPEED COMMUNICATIONS EQUIPMENT

ELECTRICAL CHARACTERISTICS¹ ($T_A = 25 \text{ }^\circ\text{C}$)

| | | PART NUMBER | | PS7200J-1A | | |
|-----------|--|--|---------------|------------|--------|-----|
| SYMBOLS | | PARAMETERS | UNITS | MIN | TYP | MAX |
| Diode | V_F | Forward Voltage, $I_F = 10 \text{ mA}$ | V | | 1.2 | 1.4 |
| | I_R | Reverse Current, $V_R = 5 \text{ V}$ | μA | | | 5.0 |
| MOS FET | I_{LOFF} | Off-State Leakage Current, $V_D = 40 \text{ V}$ | μA | | | 3.0 |
| | C_{OUT} | Output Capacitance, $V = 0 \text{ V}$, $f = 1 \text{ MHz}$ | pF | | 1.7 | |
| Coupled | I_{FON} | LED On-State Current, $I_L = 100 \text{ mA}$ | mA | | | 2 |
| | R_{ON} | On-State Resistance, $I_F = 10 \text{ mA}$, $I_L = 10 \text{ mA}$ | Ω | | 8.5 | 15 |
| | | $I_F = 10 \text{ mA}$, $I_L = 100 \text{ mA}$ | Ω | | 8.5 | 15 |
| | t_{ON} | Turn-on Time, $I_F = 10 \text{ mA}$, $V_O = 5 \text{ V}$, $PW \geq 10 \text{ ms}$ | ms | | 0.008 | 1.0 |
| | t_{OFF} | Turn-off Time, $I_F = 10 \text{ mA}$, $V_O = 5 \text{ V}$, $PW \geq 10 \text{ ms}$ | ms | | 0.3 | 100 |
| | R_{i-o} | Isolation Resistance, $V_{i-o} = 1.0 \text{ kVDC}$ | Ω | | 10^9 | |
| C_{i-o} | Isolation Capacitance, $V = 0 \text{ V}$, $f = 1 \text{ MHz}$ | pF | | 0.5 | | |

Note:

1. Turn-On, Turn-Off Time

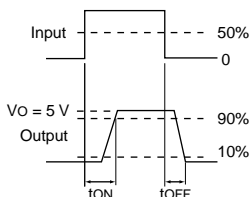

PS7200J-1A

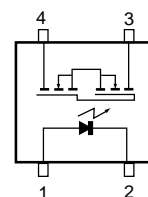

ABSOLUTE MAXIMUM RATINGS¹ (T_A = 25°C)

| SYMBOLS | PARAMETERS | UNITS | RATINGS |
|------------------|-----------------------------------|---------|-------------|
| Diode | | | |
| I _F | Forward Current (DC) | mA | 50 |
| V _R | Reverse Voltage | V | 5.0 |
| P _D | Power Dissipation | mW | 50 |
| I _{FP} | Peak Forward Current ² | A | 1 |
| MOSFET | | | |
| V _L | Break Down Voltage | V | 40 |
| I _L | Continuous Load Current | mA | 100 |
| P _D | Power Dissipation | mW | 100 |
| Coupled | | | |
| BV | Isolation Voltage ³ | Vr.m.s. | 1500 |
| P _T | Total Power Dissipation | mW | 150 |
| T _A | Operating Ambient Temp. | °C | -40 to +80 |
| T _{STG} | Storage Temperature | °C | -40 to +100 |

Notes:

1. Operation in excess of any one of these parameters may result in permanent damage.
2. PW = 100 μs, Duty Cycle = 1 %
3. AC voltage for 1 minute at T_A = 25 °C, RH = 60 % between input and output.

RECOMMENDED OPERATING CONDITIONS (T_A = 25°C)

| PART NUMBER | | PS7200J-1A | | | |
|----------------|-----------------------|------------|-----|-----|-----|
| SYMBOLS | PARAMETERS | UNITS | MIN | TYP | MAX |
| I _F | LED Operating Current | mA | 2 | 10 | 20 |
| V _F | LED Off Voltage | V | 0 | | 0.5 |

TYPICAL PERFORMANCES CURVES (T_A = 25°C)

MAXIMUM FORWARD CURRENT vs. AMBIENT TEMPERATURE

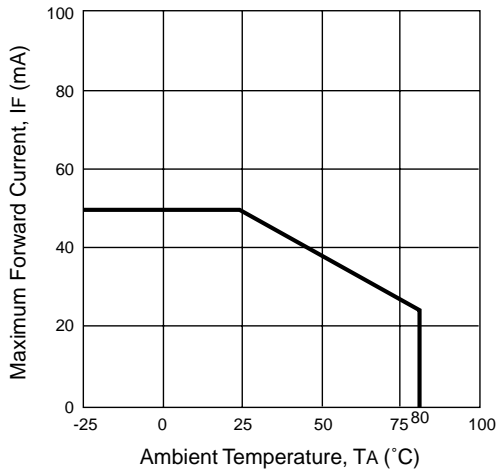

MAXIMUM LOAD CURRENT vs. AMBIENT TEMPERATURE

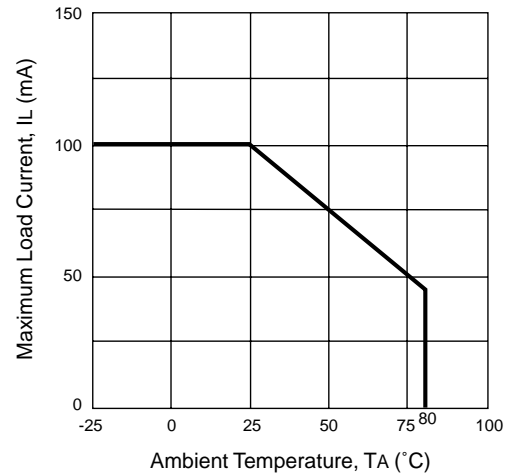

FORWARD VOLTAGE vs. AMBIENT TEMPERATURE

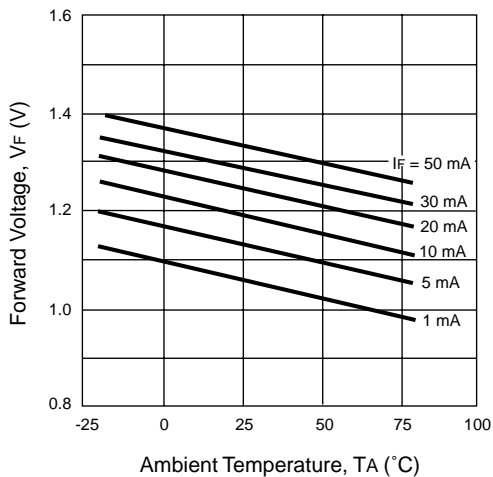

OUTPUT CAPACITANCE vs. SUPPLY VOLTAGE

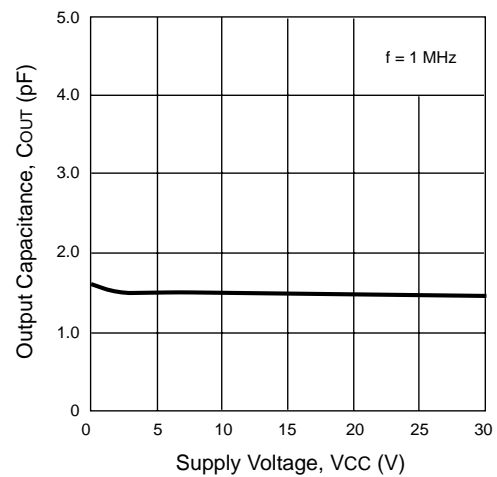

TYPICAL PERFORMANCE CURVES (TA = 25°C)

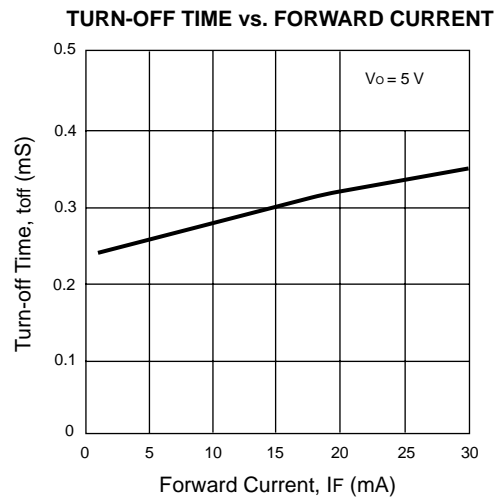
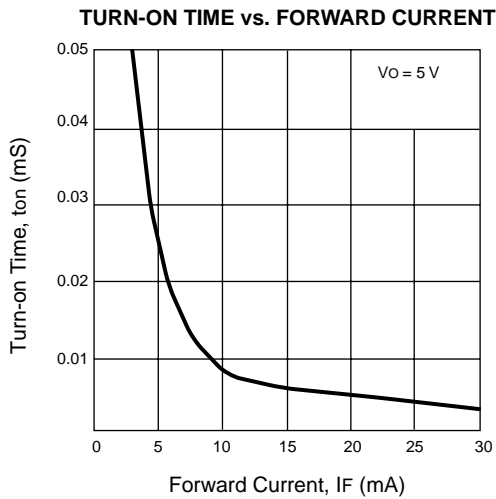
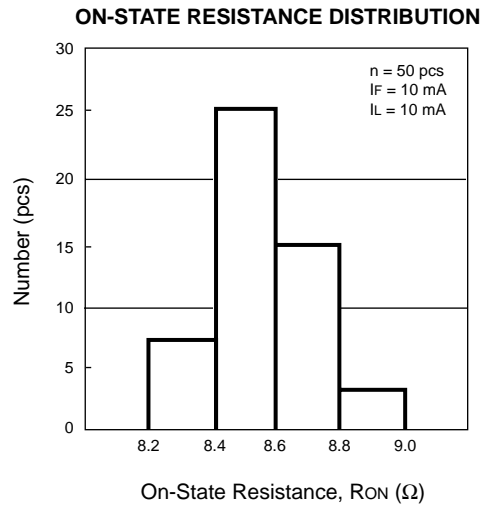
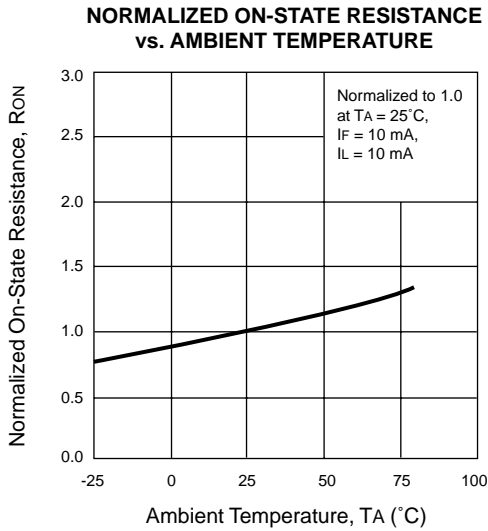
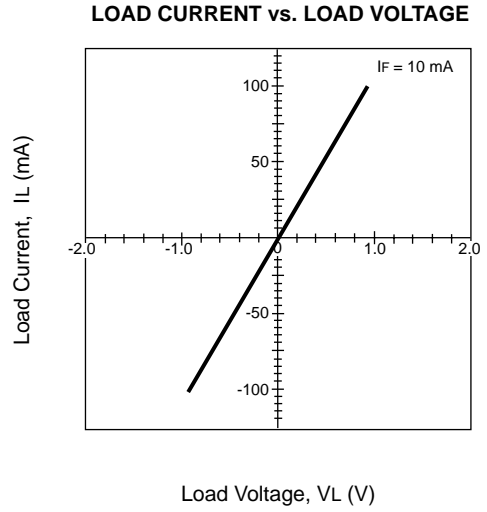
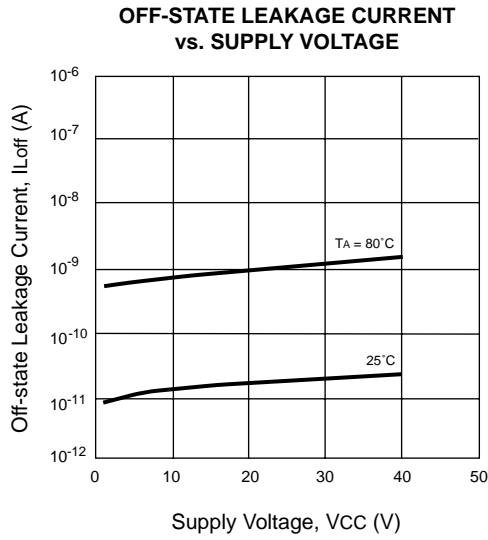

TYPICAL PERFORMANCE CURVES (TA = 25°C)

TURN-ON TIME DISTRIBUTION

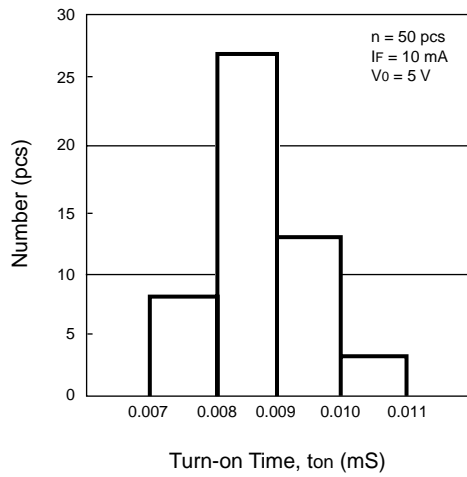

TURN-OFF TIME DISTRIBUTION

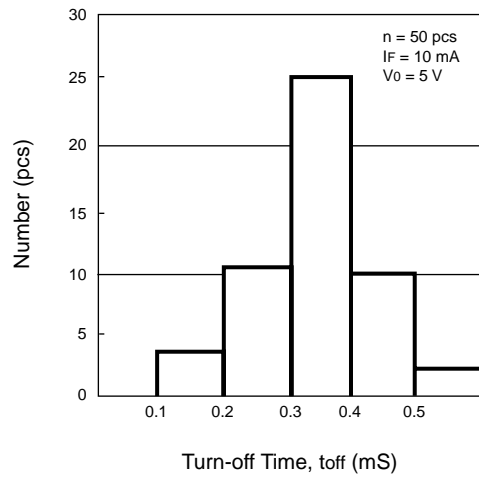

NORMALIZED TURN-ON TIME vs. AMBIENT TEMPERATURE

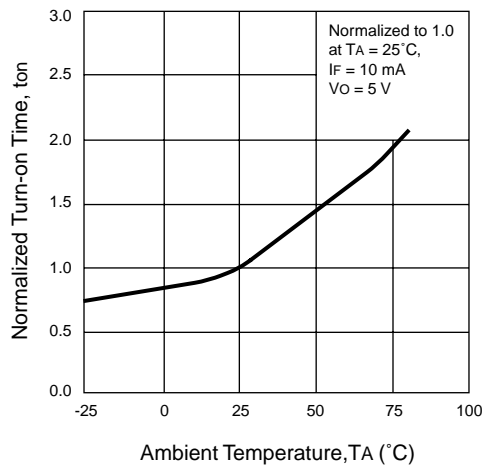

NORMALIZED TURN-OFF TIME vs. AMBIENT TEMPERATURE

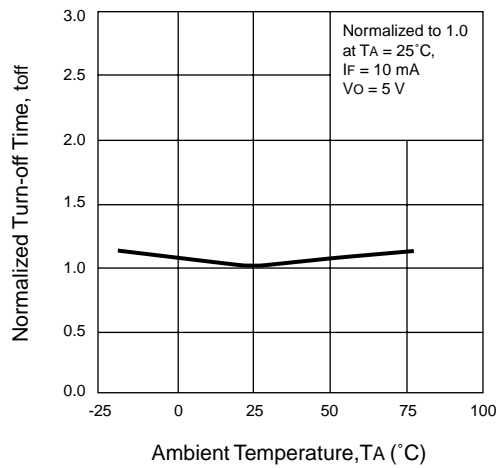

INSERTION LOSS vs. FREQUENCY

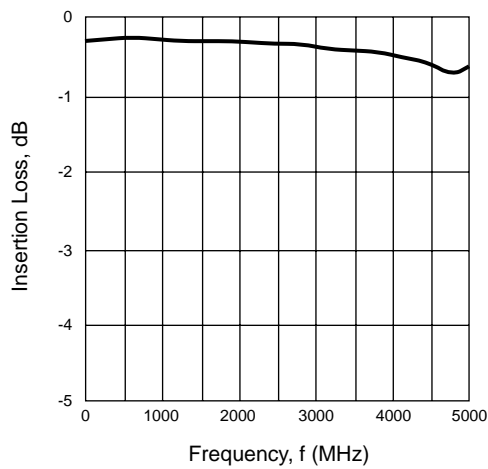

ISOLATION vs. FREQUENCY

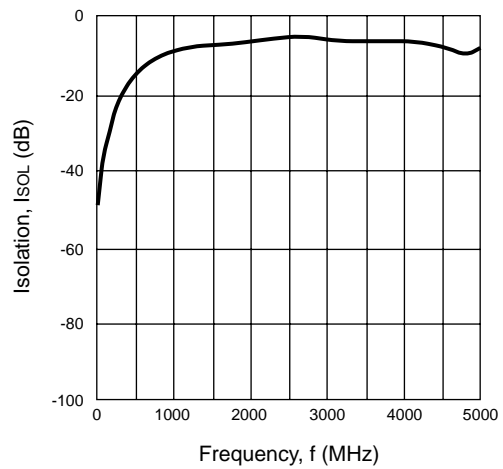

PS7200J-1A

OUTLINE DIMENSIONS (Units in mm)

PS7200J-1A

(Top View)

1. LED Anode
2. LED Cathode
3. MOSFET
4. MOSFET

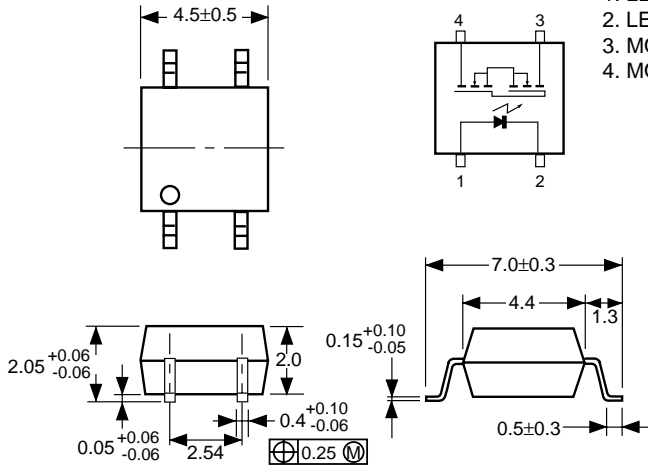

TAPING SPECIFICATIONS (Units in mm)

OUTLINE AND DIMENSIONS (TAPE)

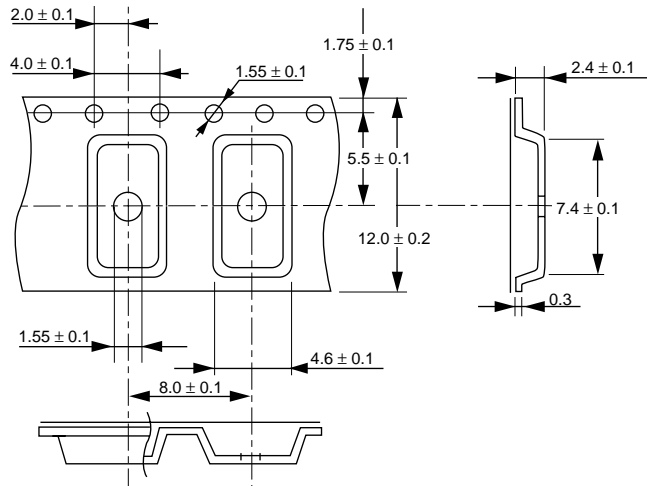

OUTLINE AND DIMENSIONS (REEL)

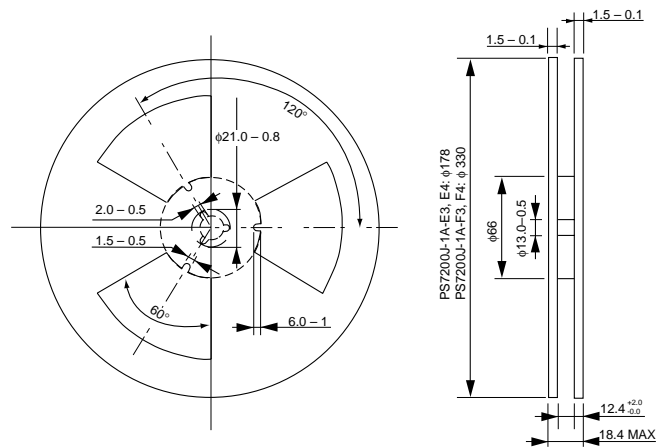

Notes:

1. Packing : PS7200J-1A-E3, E4 900 pcs.
PS7200J-1A-F3, F4 3500 pcs.

TAPE DIRECTION

PS7200J-1A-E3
PS7200J-1A-F3

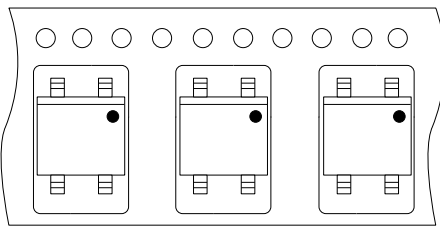

PS7200J-1A-E4
PS7200J-1A-F4

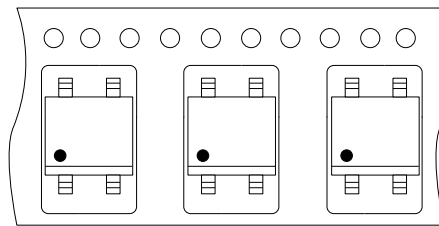

EXCLUSIVE NORTH AMERICAN AGENT FOR **NEC** RF, MICROWAVE & OPTOELECTRONIC SEMICONDUCTORS

CEL CALIFORNIA EASTERN LABORATORIES • Headquarters • 4590 Patrick Henry Drive • Santa Clara, CA 95054-1817 • (408) 988-3500 • Telex 34-6393 • FAX (408) 988-0279
24-Hour Fax-On-Demand: 800-390-3232 (U.S. and Canada only) • Internet: <http://WWW.CEL.COM>

DATA SUBJECT TO CHANGE WITHOUT NOTICE

11/30/01

Copyright © Each Manufacturing Company.

All Datasheets cannot be modified without permission.

This datasheet has been download from :

www.AllDataSheet.com

100% Free DataSheet Search Site.

Free Download.

No Register.

Fast Search System.

www.AllDataSheet.com