



NEC's 1 Mbps HIGH CMR ANALOG OUTPUT TYPE 8-PIN SOP HIGH-SPEED PHOTOCOUPLER

**PS8802-1
PS8802-2**

FEATURES

- **HIGH ISOLATION VOLTAGE**
BV: 2500 V_{r.m.s.}
- **HIGH COMMON MODE TRANSIENT IMMUNITY**
CMH, CML = ±10 kV/ μs MIN
- **HIGH SUPPLY VOLTAGE**
V_{cc} = 35 V
- **HIGH-SPEED RESPONSE**
t_{PHL} = 0.8 μs MAX, t_{PLH} = 1.2 μs MAX

DESCRIPTION

NEC's PS8802-1 and PS8802-2 is an optically coupled isolator containing a GaAlAs LED on the light emitting side (input side) and a PIN photodiode and a high-speed amplifier transistor on the output side on one chip.

This is a plastic S08 type for high density applications.

APPLICATIONS

- COMPUTERS AND PERIPHERALS
- GENERAL PURPOSE INVERTER
- SUBSTITUTIONS FOR RELAYS AND PULSE TRANSFORMERS
- POWER SUPPLY
- FACTORY AUTOMATION
- SERIAL BUS ISOLATION

ELECTRICAL CHARACTERISTICS (T_A = 25°C)

		PART NUMBER	PS8802-1, PS8802-2			
	SYMBOLS	PARAMETERS	UNITS	MIN	TYP	MAX
Diode	V _F	Forward Voltage, I _F = 16 mA	V		1.7	2.2
	I _R	Reverse Current, V _R = 3 V	μA			10
	ΔV _F /ΔT	Forward Voltage Temperature Coefficient, I _F = 16 mA	mV/°C		-2.1	
	C _t	Terminal Capacitance, V = 0, f = 1 MHz	pF		30	
Detector	I _{OH} (1)	High Level Output Current, I _F = 0 mA, V _{cc} = V _O = 5.5 V	nA		3	500
	I _{OH} (2)	High Level Output Current, I _F = 0 mA, V _{cc} = V _O = 30 V	μA			100
	V _{OL}	Low Level Output Voltage, I _F = 16 mA, V _{cc} = 4.5 V, I _O = 1.2 mA	V		0.1	0.4
	I _{CCL}	Low Level Supply Current, I _F = 16 mA, V _O = open, V _{cc} = 30 V	μA		50	
	I _{CCH}	High Level Supply Current, I _F = 0 mA, V _O = open, V _{cc} = 30 V			0.01	2
Coupled	CTR	Current Transfer Ratio (I _C /I _F), I _F = 16 mA, V _{cc} = 30 V, V _O = 0.4 V	%	15	20	35
	R _{I-O}	Isolation Resistance, V _{I-O} = 1 kV _{dc} , R _H = 40 to 60 %	Ω	10 ¹¹		
	C _{I-O}	Isolation Capacitance, C _{I-O} = V = 0, f = 1 MHz	pF		0.4	
	t _{PHL}	Propagation Delay Time (H→L) ¹ , I _F = 16 mA, V _{cc} = 30 V, R _L = 2.2 kΩ, C _L = 15 pF	μs		0.5	0.8
	t _{PLH}	Propagation Delay Time (L→H) ¹ , I _F = 16 mA, V _{cc} = 30 V, R _L = 2.2 kΩ, C _L = 15 pF			0.6	1.2
	CMH	Common Mode Transient Immunity at High Level Output, I _F = 0 mA, V _{cc} = 5 V, R _L = 2.2 kΩ, V _{CM} = 1.5 kV	kV/μs		10	
	Common Mode Transient Immunity at Low Level Output, I _F = 16 mA, V _{cc} = 5 V, R _L = 4.1 kΩ, V _{CM} = 1.5 kV			-10		

(See notes on next page)



Notes:

1. Test circuit for propagation delay time

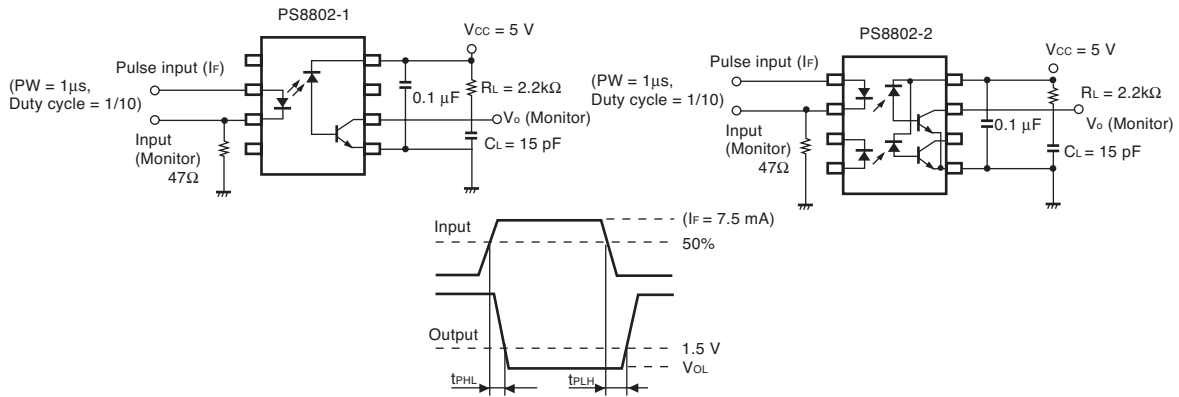

2. Test circuit for common mode transient immunity.

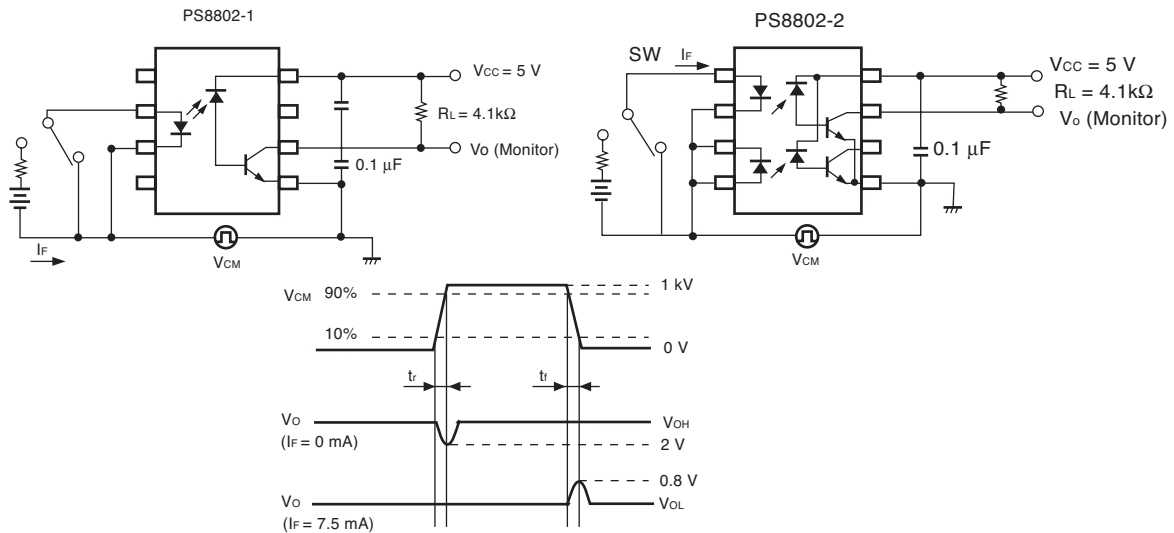

ABSOLUTE MAXIMUM RATINGS¹ (TA = 25°C)

SYMBOLS	PARAMETERS	UNITS	RATINGS PS8802-1,-2
Diode			
IF	Forward Current (DC)	mA	25
VR	Reverse Voltage	V	5.0
PD	Power Dissipation	mW	45
Detector			
VCC	Supply Voltage	V	35
Vo	Output Voltage	V	35
Io	Output Current	mA	8.0
Pc	Power Dissipation	mW	100
Coupled			
BV	Isolation Voltage ²	V _{r.m.s.}	2500
TSTG	Storage Temperature	°C	-55 to +150
TA	Operating Ambient Temperature	°C	-55 to +100

Notes:

1. Operation in excess of any one of these parameters may result in permanent damage.
2. Reduced to 1.00 mw/°C at TA = 25°C or more.
3. AC voltage for 1 minute at TA = 25 °C, RH = 60 % between input and output.

PS8802-1, PS8802-2

OUTLINE DIMENSIONS (Units in mm)

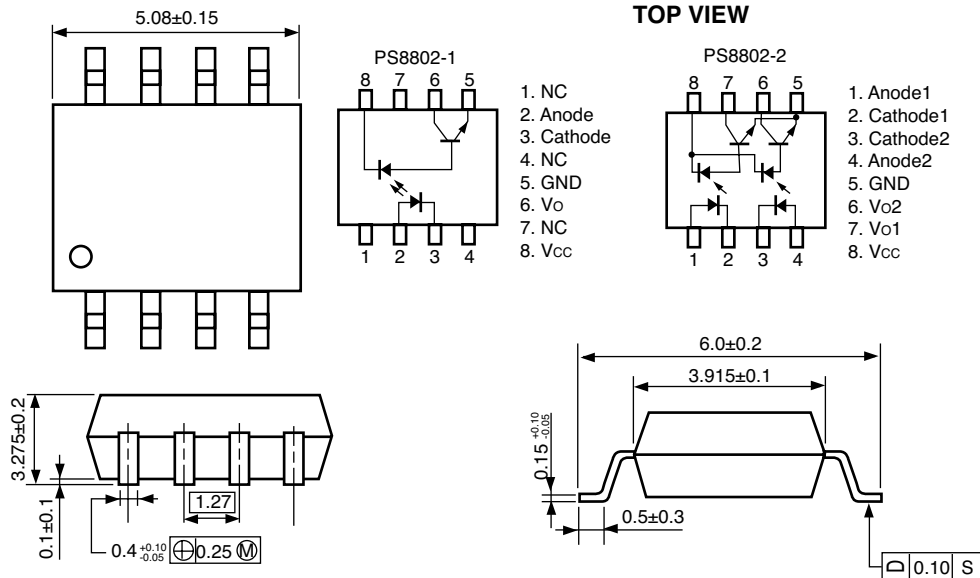

Life Support Applications

These NEC products are not intended for use in life support devices, appliances, or systems where the malfunction of these products can reasonably be expected to result in personal injury. The customers of CEL using or selling these products for use in such applications do so at their own risk and agree to fully indemnify CEL for all damages resulting from such improper use or sale.