



# PSMS05 thru PSMS24C

## STANDARD CAPACITANCE TVS ARRAY

### APPLICATIONS

- ✓ Ethernet - 10 Base T
- ✓ Cellular Phones
- ✓ Handheld Electronics
- ✓ FireWire & USB Interfaces

### IEC COMPATIBILITY (EN61000-4)

- ✓ 61000-4-2 (ESD): Air - 15kV, Contact - 8kV
- ✓ 61000-4-4 (EFT): 40A - 5/50ns
- ✓ 61000-4-5 (Surge): 12A, 8/20 $\mu$ s - Level 1(Line-Gnd) & Level 2(Line-Line)

### FEATURES

- ✓ 350 Watts Peak Pulse Power per Line (tp=8/20 $\mu$ s)
- ✓ Monolithic Design
- ✓ Available in Multiple Voltage Types Ranging From 5V to 24V
- ✓ Protect 4 Lines
- ✓ ESD Protection > 25 kilovolts
- ✓ Low Clamping Voltage
- ✓ Unidirectional & Bidirectional Configurations
- ✓ Low Leakage Current

### MECHANICAL CHARACTERISTICS

- ✓ Molded JEDEC SOT-23-6 Package
- ✓ Weight 0.6 grams (Approximate)
- ✓ Flammability rating UL 94V-0
- ✓ 8mm Tape and Reel Per EIA Standard 481
- ✓ Marking: Marking Code & Pin One Defined By DOT on Package



### PIN CONFIGURATIONS

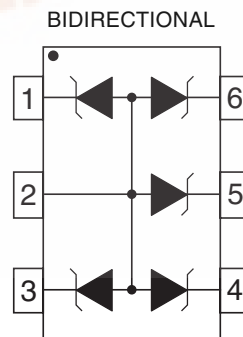
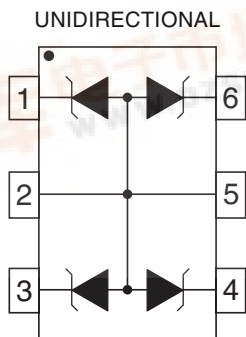

**DEVICE CHARACTERISTICS**

MAXIMUM RATINGS @ 25°C Unless Otherwise Specified			
PARAMETER	SYMBOL	VALUE	UNITS
Peak Pulse Power ( $t_p = 8/20\mu s$ ) - See Figure 1	$P_{PP}$	350	Watts
Operating Temperature	$T_J$	-55°C to 150°C	°C
Storage Temperature	$T_{STG}$	-55°C to 150°C	°C

ELECTRICAL CHARACTERISTICS PER LINE @ 25°C Unless Otherwise Specified							
PART NUMBER (See Notes 1-3)	DEVICE MARKING	RATED STAND-OFF VOLTAGE	MINIMUM BREAKDOWN VOLTAGE	MAXIMUM CLAMPING VOLTAGE (See Fig. 2)	MAXIMUM CLAMPING VOLTAGE (See Fig. 2)	MAXIMUM LEAKAGE CURRENT	TYPICAL CAPACITANCE (See Note 4)
		$V_{WM}$ VOLTS	@ 1mA $V_{(BR)}$ VOLTS	@ $I_p = 1A$ $V_C$ VOLTS	@ 8/20 $\mu s$ $V_C @ I_{PP}$	@ $V_{WM}$ $I_D$ $\mu A$	@ 0V, 1 MHz $C_j$ pF
PSMS05	PRH	5.0	6.0	9.8	21.0V @ 17.0A	20	150
PSMS05C	PRL	5.0	6.0	9.8	21.0V @ 17.0A	20	150
PSMS12	PRI	12.0	13.3	19	29.2V @ 12.0A	1	80
PSMS12C	PRM	12.0	13.3	19	29.2V @ 12.0A	1	80
PSMS15	PRJ	15.0	16.7	24	34.6V @ 10.0A	1	50
PSMS15C	PRN	15.0	16.7	24	34.6V @ 10.0A	1	50
PSMS24	PRK	24.0	26.7	40	58.3V @ 6.0A	1	40
PSMS24C	PRO	24.0	26.7	40	58.3V @ 6.0A	1	40

- Note 1:** Part numbers with an additional "C" suffix are bidirectional devices, i.e., PSMS05C.  
**Note 2:** *Unidirectional Only:* Test between pin 1 to 2 or 5, 4 to 2 or 5, 6 to 2 or 5, 3 to 2 or 5.  
**Note 3:** *Bidirectional Only:* Test between pin 5 to 1 or 3 or 4 or 6. Electrical characteristics apply in both directions.  
**Note 4:** *Unidirectional Only:* Capacitance measured between pins 1, 3, 4, 6, to 2.

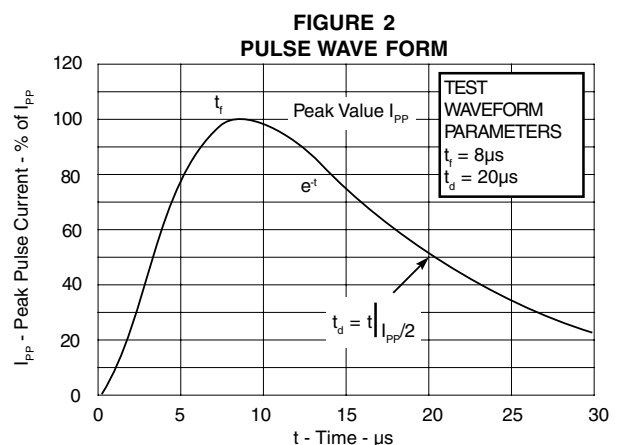
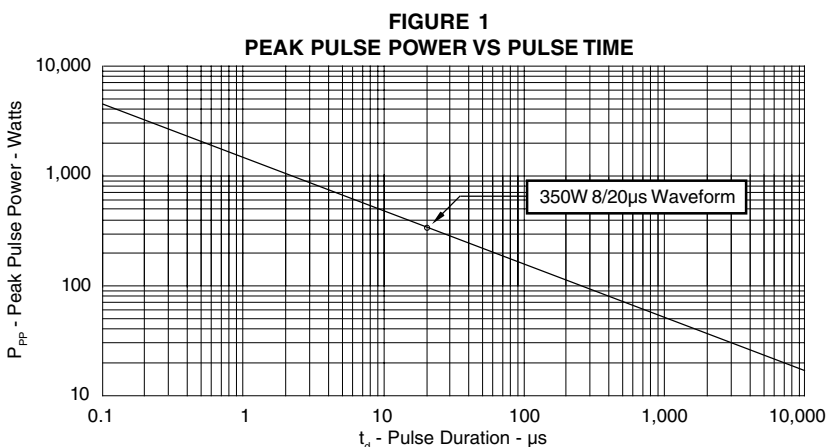

GRAPHS

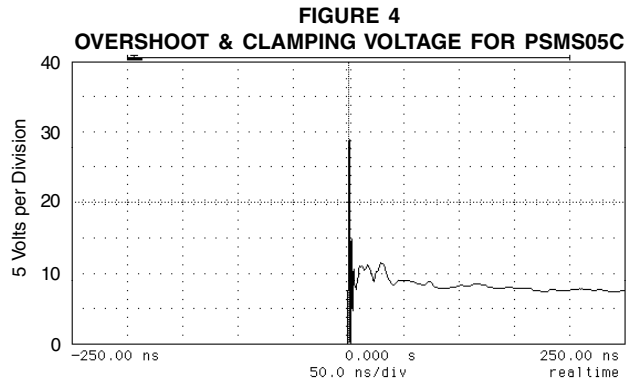
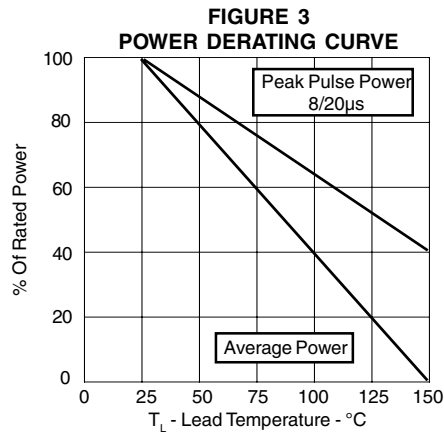

ESD Test Pulse: 25 kilovolt, 1/30ns (waveform)

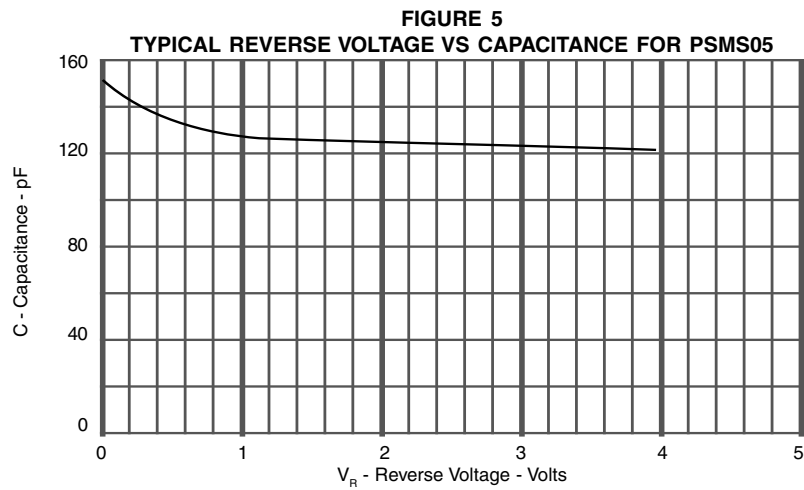

## APPLICATION NOTE

The PSMS Series are TVS arrays designed to protect I/O or data lines from the damaging effects of ESD or EFT. This product series provides both unidirectional and bidirectional protection, with a surge capability of 350 Watts  $P_{PP}$  per line for an 8/20 $\mu$ s waveform and ESD protection > 25 kilovolts.

### UNIDIRECTIONAL COMMON-MODE CONFIGURATION (Figure 1)

The PSMS Series provides up to four (4) lines of protection in a common-mode configuration as depicted in Figure 1.

Circuit connectivity is as follows:

- ✓ Line 1 is connected to Pin 1.
- ✓ Line 2 is connected to Pin 3.
- ✓ Line 3 is connected to Pin 4.
- ✓ Line 4 is connected to Pin 6.
- ✓ Pin 5 is connected to ground.
- ✓ Pin 2 is not connected.

### BIDIRECTIONAL COMMON-MODE CONFIGURATION (Figure 2)

The PSMSxxC Series provides up to four (4) lines of protection in a common-mode configuration as depicted in Figure 2.

Circuit connectivity is as follows:

- ✓ Line 1 is connected to Pin 1.
- ✓ Line 2 is connected to Pin 3.
- ✓ Line 3 is connected to Pin 4.
- ✓ Line 4 is connected to Pin 5.
- ✓ Pin 6 is connected to ground.
- ✓ Pin 2 is not connected.

### CIRCUIT BOARD LAYOUT RECOMMENDATIONS

Circuit board layout is critical for Electromagnetic Compatibility (EMC) protection. The following guidelines are recommended:

- ✓ The protection device should be placed near the input terminals or connectors, the device will divert the transient current immediately before it can be coupled into the nearby traces.
- ✓ The path length between the TVS device and the protected line should be minimized.
- ✓ All conductive loops including power and ground loops should be minimized.
- ✓ The transient current return path to ground should be kept as short as possible to reduce parasitic inductance.
- ✓ Ground planes should be used whenever possible. For multilayer PCBs, use ground vias.

Figure 1 - Unidirectional Configuration  
Common-Mode I/O Port Protection

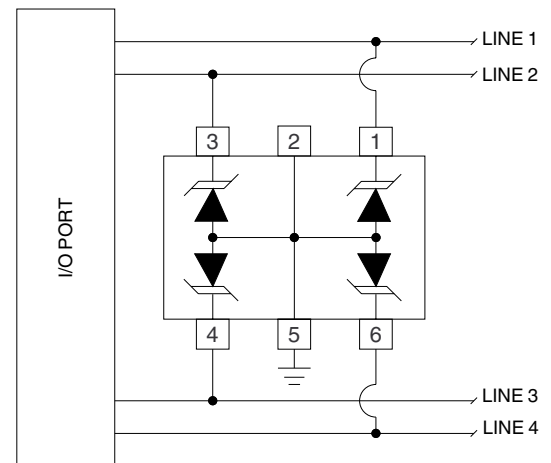
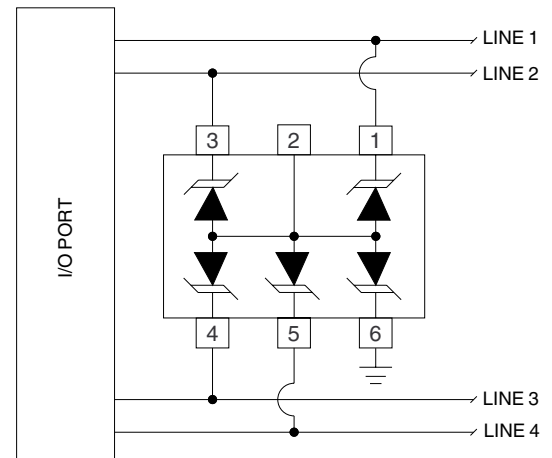

Figure 2 - Bidirectional Configuration  
Common-Mode I/O Port Protection



# PSMS05 thru PSMS24C

## PACKAGE OUTLINE & DIMENSIONS

### PACKAGE OUTLINE

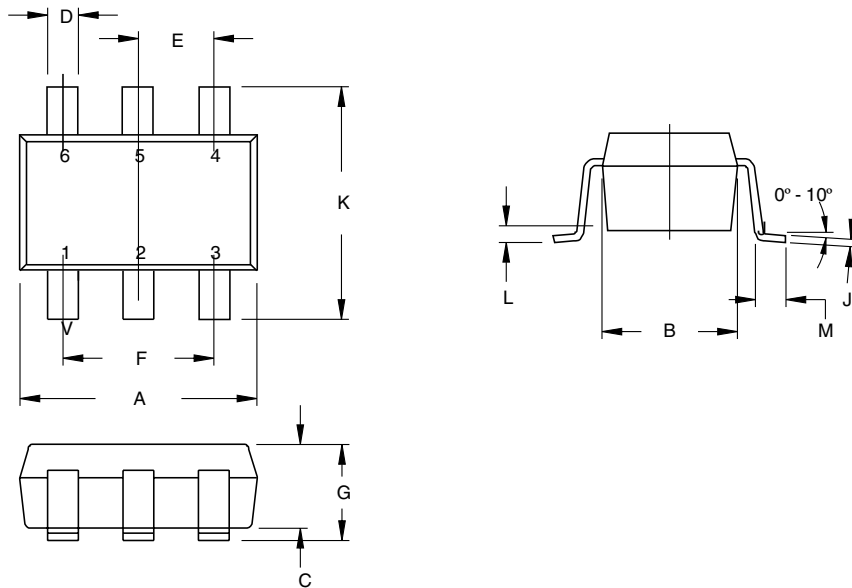

### SOT-23-6



### PACKAGE DIMENSIONS

DIM	MILLIMETERS		INCHES	
	MIN	MAX	MIN	MAX
A	2.80	3.05	0.110	0.120
B	1.50	1.75	0.059	0.070
C	0.90	1.30	0.036	0.051
D	0.35	0.50	0.014	0.020
E	0.85	1.05	0.033	0.040
F	1.70	2.10	0.067	0.083
G	0.90	1.45	0.036	0.057
J	0.090	0.20	0.0035	0.008
K	2.60	3.00	0.102	0.118
L	0.20 TYP	0.20 TYP	0.007 TYP	0.007 TYP
M	0.35	0.55	0.014	0.022

### MOUNTING PAD

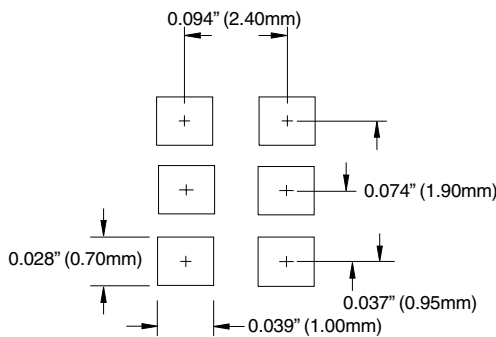

### NOTES

1. Dimensioning and tolerances per ANSI Y14.5M, 1985.
2. Controlling Dimension: Inches
3. Dimensions are exclusive of mold flash and metal burrs.

### TAPE & REEL ORDERING NOMENCLATURE

1. Surface mount product is taped and reeled in accordance with EIA-481.
2. Suffix-T7 = 7 Inch Reel - 3,000 pieces per 8mm tape, i.e., *PSMS05-T7*.
3. Suffix-T13 = 13 Inch Reel - 10,000 pieces per 8mm tape, i.e., *PSMS05-T13*.

Outline & Dimensions: Rev 1 - 11/01, 06013

COPYRIGHT © ProTek Devices 2003

SPECIFICATIONS: ProTek reserves the right to change the electrical and or mechanical characteristics described herein without notice (except JEDEC).

DESIGN CHANGES: ProTek reserves the right to discontinue product lines without notice, and that the final judgement concerning selection and specifications is the buyer's and that in furnishing engineering and technical assistance, ProTek assumes no responsibility with respect to the selection or specifications of such products.

**ProTek Devices**

2929 South Fair Lane, Tempe, AZ 85282

Tel: 602-431-8101 Fax: 602-431-2288

E-Mail: [sales@protekdevices.com](mailto:sales@protekdevices.com)

Web Site: [www.protekdevices.com](http://www.protekdevices.com)