

PTF 10133

85 Watts, 860–960 MHz

GOLDMOS™ Field Effect Transistor

Description

The PTF 10133 is an internally matched 85 watt LDMOS FET intended for cellular, GSM and D-AMPS applications. This device operates at 50% efficiency with 13.5 dB of gain. Full gold metallization ensures excellent device lifetime and reliability.

- **INTERNALLY MATCHED**
- **Performance at 894 MHz, 28 Volts**
 - Output Power = 85 Watts
 - Power Gain = 13.5 dB Typ
 - Efficiency = 50% Typ
- Full Gold Metallization
- Silicon Nitride Passivated
- Excellent Thermal Stability
- 100% Lot Traceability

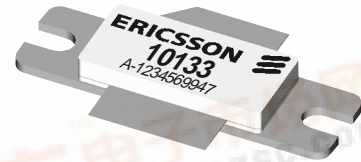
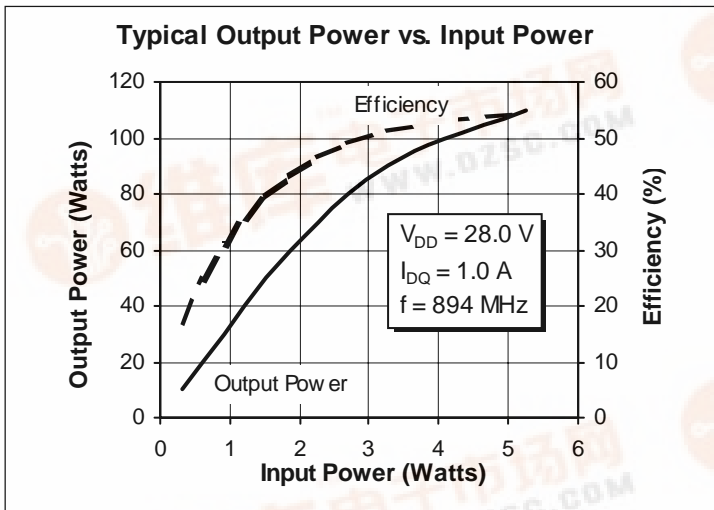

Package 20248

RF Specifications (100% Tested)

Characteristic	Symbol	Min	Typ	Max	Units
Gain ($V_{DD} = 28\text{ V}$, $P_{OUT} = 85\text{ W}$, $I_{DQ} = 1.0\text{ A}$, $f = 894\text{ MHz}$)	G_{ps}	12.5	13.5	—	dB
Power Output at 1 dB Compression ($V_{DD} = 28\text{ V}$, $I_{DQ} = 1.0\text{ A}$, $f = 894\text{ MHz}$)	P-1dB	85	90	—	Watts
Drain Efficiency ($V_{DD} = 28\text{ V}$, $P_{OUT} = 85\text{ W}$, $I_{DQ} = 1.0\text{ A}$, $f = 894\text{ MHz}$)	η	45	50	—	%
Load Mismatch Tolerance ($V_{DD} = 28\text{ V}$, $P_{OUT} = 85\text{ W}$, $I_{DQ} = 1.0\text{ A}$, $f = 894\text{ MHz}$ —all phase angles at frequency of test)	Ψ	—	—	10:1	—

All published data at $T_{CASE} = 25^\circ\text{C}$ unless otherwise indicated.

Electrical Characteristics (100% Tested)

Characteristic	Conditions	Symbol	Min	Typ	Max	Units
Drain-Source Breakdown Voltage	$V_{GS} = 0\text{ V}, I_D = 25\text{ mA}$	$V_{(BR)DSS}$	65	—	—	Volts
Drain-Source Leakage Current	$V_{DS} = 28\text{ V}, V_{GS} = 0\text{ V}$	I_{DSS}	—	—	1.0	mA
Gate Threshold Voltage	$V_{DS} = 10\text{ V}, I_D = 75\text{ mA}$	$V_{GS(th)}$	3.0	—	5.0	Volts
Forward Transconductance	$V_{DS} = 10\text{ V}, I_D = 3\text{ A}$	g_{fs}	—	3.0	—	Siemens

Maximum Ratings

Parameter	Symbol	Value	Unit
Drain-Source Voltage	V_{DSS}	65	Vdc
Gate-Source Voltage	V_{GS}	± 20	Vdc
Operating Junction Temperature	T_J	200	$^{\circ}\text{C}$
Total Device Dissipation Above 25°C derate by	P_D	205 1.18	Watts $\text{W}/^{\circ}\text{C}$
Storage Temperature Range	T_{STG}	-40 to $+150$	$^{\circ}\text{C}$
Thermal Resistance ($T_{CASE} = 70^{\circ}\text{C}$)	$R_{\theta JC}$	0.85	$^{\circ}\text{C}/\text{W}$

Typical Performance

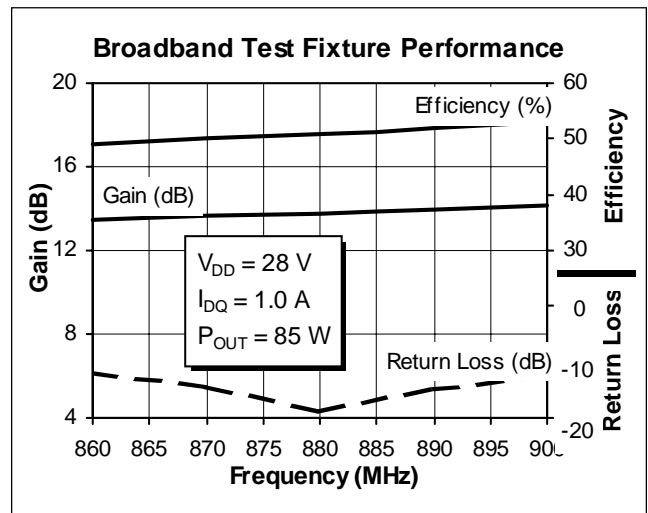
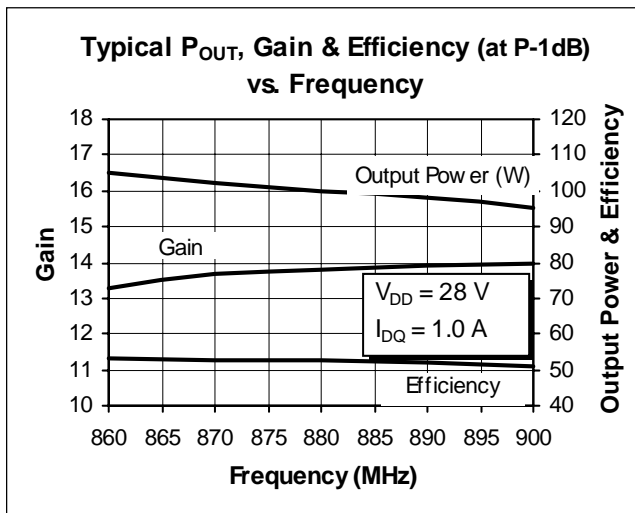

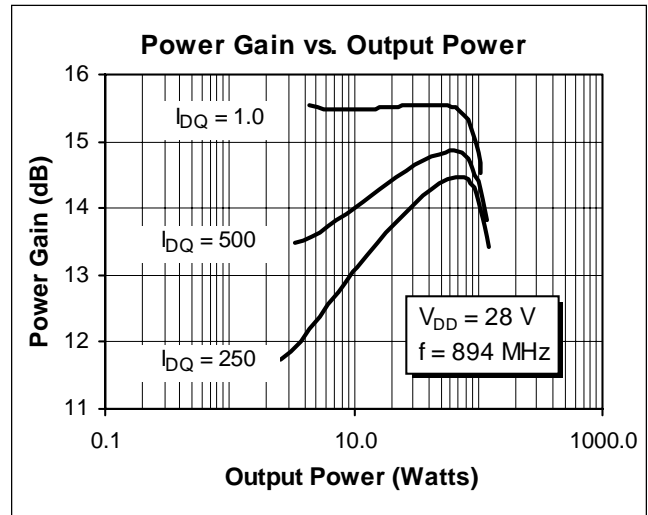
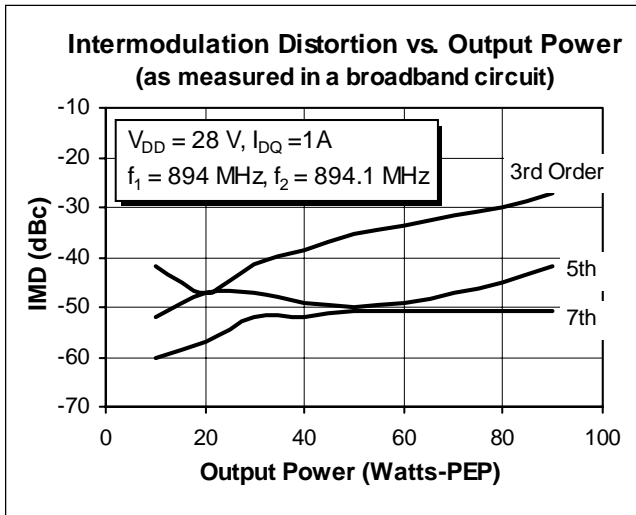
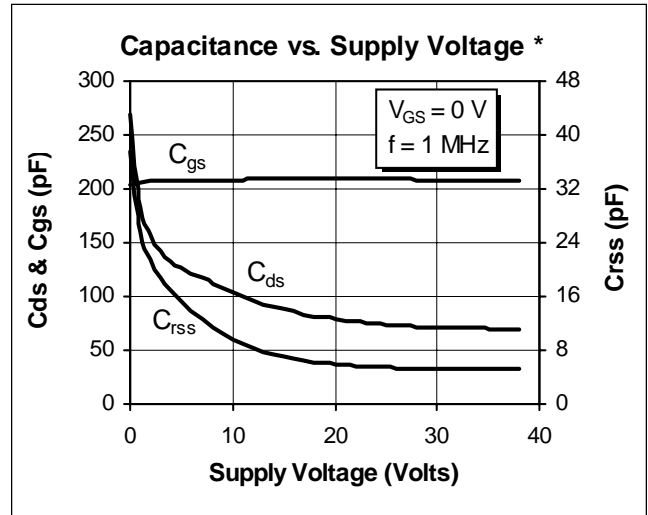
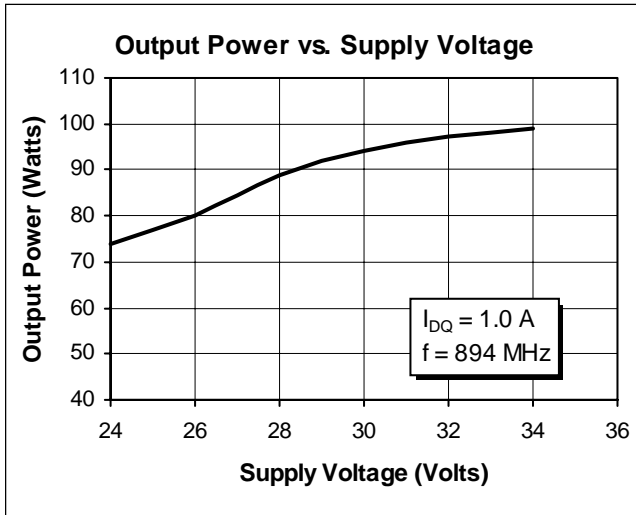

* This part is internally matched. Measurements of the finished product will not yield these figures.

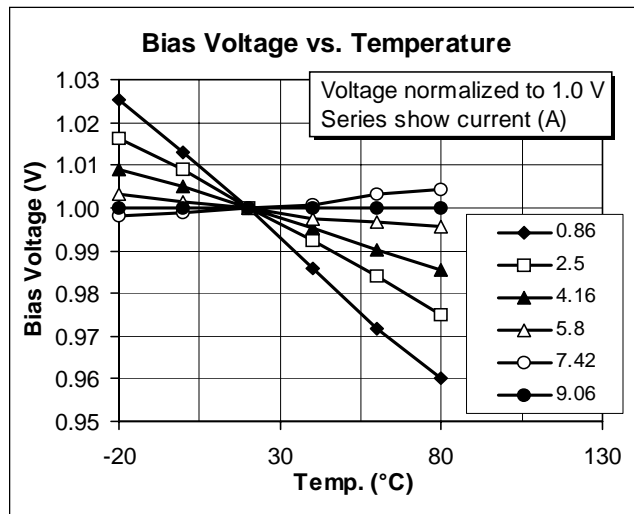

PTF 10133



Impedance Data

($V_{DD} = 28\text{ V}$, $P_{OUT} = 85\text{ W}$, $I_{DQ} = 1.0\text{ A}$)

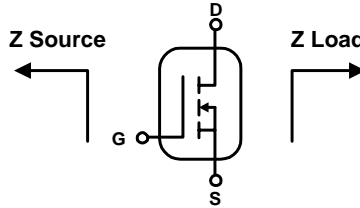

Frequency MHz	Z Source Ω		Z Load Ω	
	R	jX	R	jX
860	3.2	-3.2	1.3	1.2
870	3.6	-3.2	1.3	1.1
880	4.1	-3.2	1.3	0.9
890	4.7	-3.1	1.3	0.8
900	5.3	-2.9	1.2	0.8
925	7.0	-2.0	1.2	0.7
942	8.1	-0.6	1.2	0.7
960	7.7	1.1	1.2	0.6

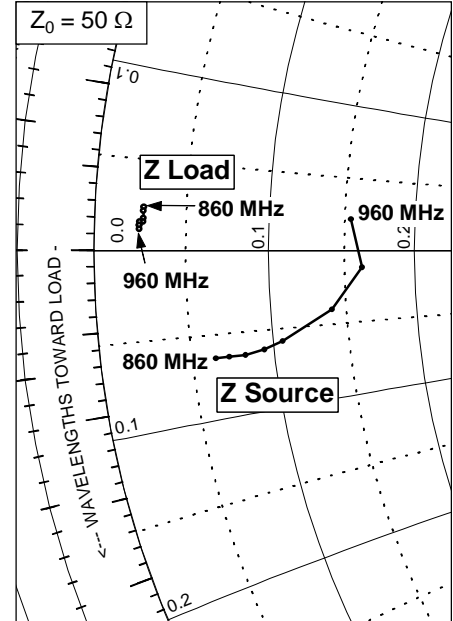

Typical Scattering Parameters

($V_{DS} = 28\text{ V}$, $I_D = 2\text{ A}$ per side)

f (MHz)	S11		S21		S12		S22	
	Mag	Ang	Mag	Ang	Mag	Ang	Mag	Ang
300	0.980	-178	0.996	15.6	0.010	-85.2	0.994	-177
350	0.982	-179	0.773	12.8	0.008	-85.3	0.993	-177
400	0.983	-180	0.641	9.48	0.006	-85.7	0.992	-178
450	0.989	179	0.545	7.19	0.005	-85.3	0.996	-179
500	0.989	179	0.489	5.48	0.003	-93.7	0.999	-179
550	0.987	179	0.449	2.11	0.002	-74.5	0.995	-179
600	0.983	178	0.425	-0.90	0.002	-64.9	0.996	-179
650	0.982	177	0.414	-4.52	0.001	-68.5	0.998	-180
700	0.980	176	0.405	-10.2	0.001	-55.1	0.997	-180
750	0.972	175	0.419	-14.3	0.001	-88.5	0.997	180
800	0.958	174	0.442	-19.9	0.001	-87.2	0.993	180
850	0.929	171	0.509	-27.5	0.005	-105	0.991	179
900	0.858	168	0.662	-42.4	0.013	-133	0.989	179
950	0.693	173	0.882	-75.9	0.030	174	0.987	179
1000	0.783	-170	0.714	-125	0.028	120	0.993	179
1050	0.918	-172	0.423	-153	0.022	101	0.989	179
1100	0.951	-175	0.261	-167	0.020	89.2	0.982	179
1150	0.974	-177	0.184	-179	0.019	81.8	0.982	178
1200	0.988	-178	0.124	165	0.018	77.9	0.990	178
1250	0.984	-179	0.060	158	0.017	76.7	0.990	178
1300	0.979	-180	0.048	-154	0.018	77.4	0.986	178
1350	0.980	180	0.070	179	0.018	73.9	0.983	178
1400	0.992	180	0.058	166	0.018	74.5	0.990	177
1450	0.991	179	0.049	156	0.019	78.7	0.992	178
1500	0.986	178	0.042	149	0.021	79.7	0.984	178

Test Circuit

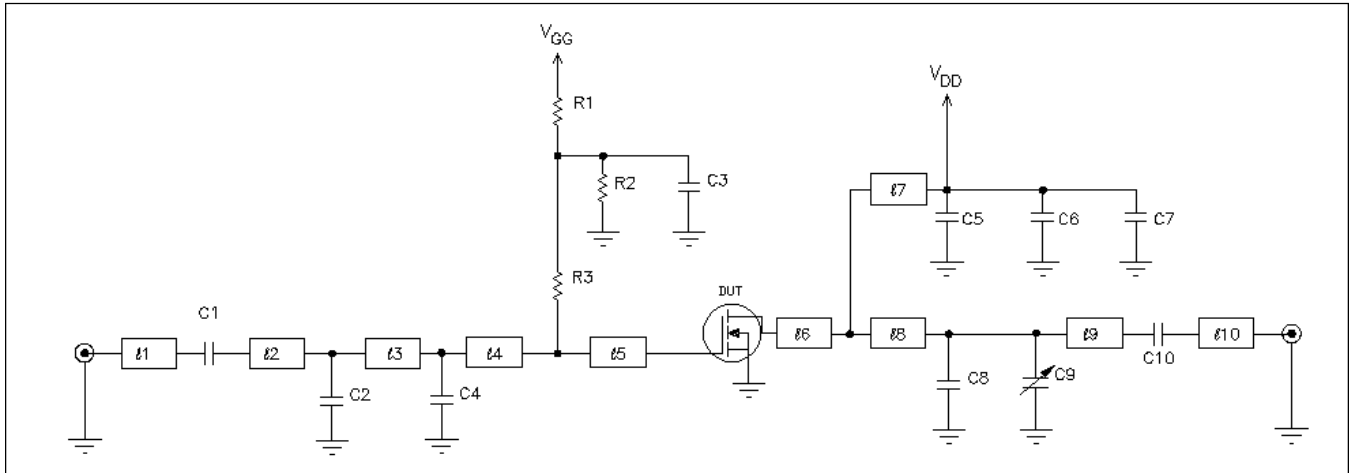

Test Circuit Schematic for $f = 894$ MHz

DUT	PTF 10133	LDMOS Field Effect Transistor	C1, C3, C5, C10	Capacitor, 36 pF	ATC 100 B
l1	0.040 λ 894 GHz	Microstrip 50 Ω	C2	Capacitor, 4.3 pF	ATC 100 B
l2	0.096 λ 894 GHz	Microstrip 50 Ω	C4	Capacitor, 6.2 pF	ATC 100 B
l3	0.098 λ 894 GHz	Microstrip 50 Ω	C6	Capacitor, 0.1 μ F, 50 V	Digi-Key P4525-ND
l4	0.073 λ 894 GHz	Microstrip 9.29 Ω	C7	Capacitor, 100 μ F, 50 V	Digi-Key P5182-ND
l5	0.107 λ 894 GHz	Microstrip 9.29 Ω	C8	Capacitor, 2.0 pF	ATC 100 B
l6	0.110 λ 894 GHz	Microstrip 6.98 Ω	C9	Capacitor, 0.6-6 pF	ATC 100 B
l7	0.250 λ 894 GHz	Microstrip 77.9 Ω	R1, R2, R3	Resistor, 220 Ω	Digi-Key 1KQBK
l8	0.081 λ 894 GHz	Microstrip 6.98 Ω	Circuit Board	$\epsilon_r = 4.0$, .028 Dielectric Thickness, 1 Oz.	
l9	0.178 λ 894 GHz	Microstrip 50 Ω	Circuit Board	.028" Dielectric Thickness, $\epsilon_r = 4.0$, AlliedSignal, G200, 2 oz. copper	
l10	0.040 λ 894 GHz	Microstrip 50 Ω			

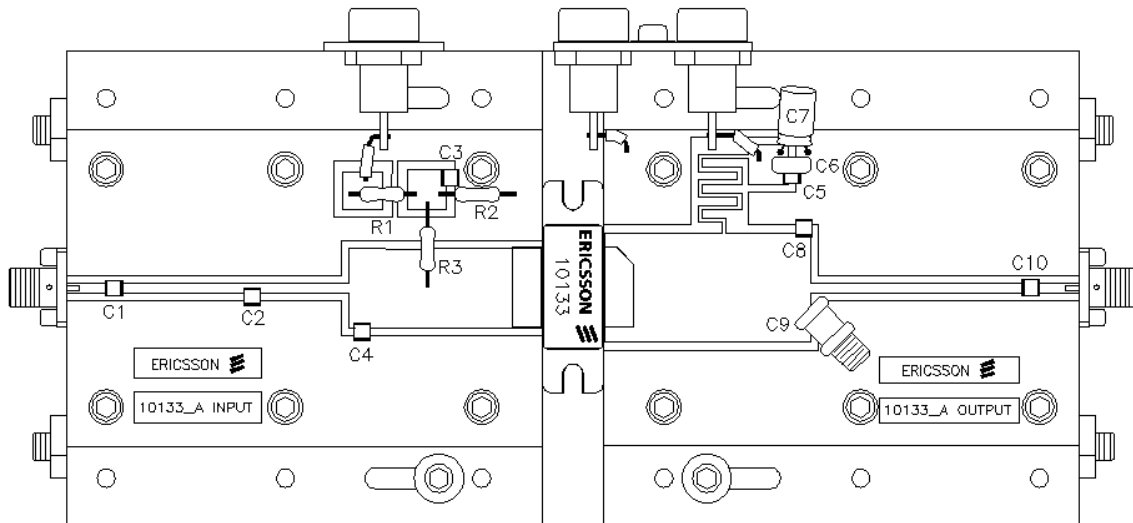

Components Layout (not to scale)

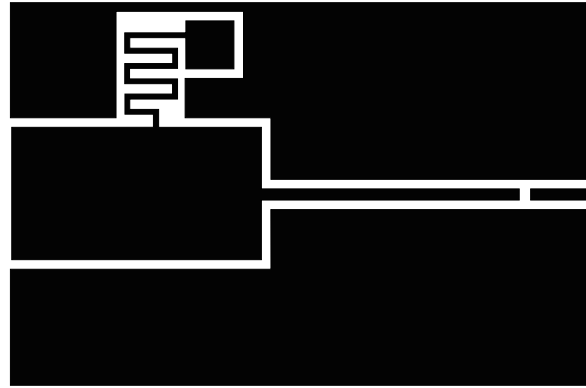
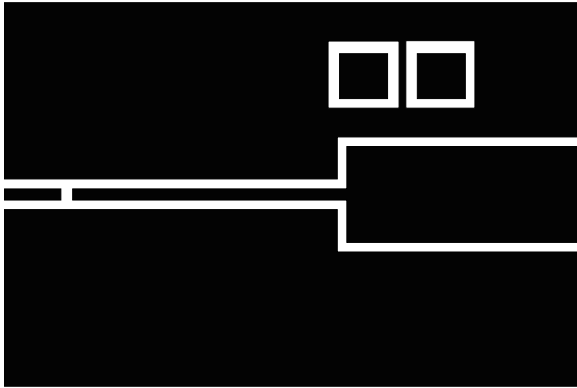

Artwork (1 inch )

Package Mechanical Specifications

