

PTF 10135

5 Watts, 2.0 GHz

GOLDMOS™ Field Effect Transistor

Description

The PTF 10135 is a common source N-channel enhancement-mode lateral MOSFET intended for large signal applications from 1.0 to 2.0 GHz. It is rated at 5 watts minimum output power. Nitride surface passivation and gold metallization ensure excellent device lifetime and reliability. 100% lot traceability is standard.

- **Guaranteed Performance at 1.99 GHz, 26 V**
- Output Power = 5 Watts Min
- Power Gain = 11 dB Min
- **Gold Metallization**
- **Silicon Nitride Passivated**
- **Back Side Common Source**
- **Excellent Thermal Stability**

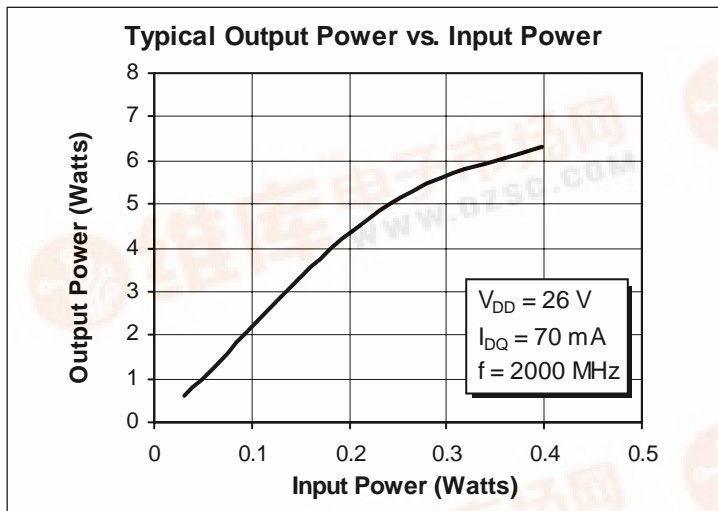

Maximum Ratings

Parameter	Symbol	Value	Unit
Drain-Source Voltage	V_{DSS}	65	Vdc
Gate-Source Voltage	V_{GS}	± 20	Vdc
Operating Junction Temperature	T_J	200	$^{\circ}\text{C}$
Total Device Dissipation at $T_{flange} = 25^{\circ}\text{C}$ Above 25°C derate by	P_D	39 0.22	Watts $\text{W}/^{\circ}\text{C}$
Storage Temperature Range	T_{STG}	-40 to +150	$^{\circ}\text{C}$
Thermal Resistance ($T_{flange} = 70^{\circ}\text{C}$)	$R_{\theta JC}$	4.5	$^{\circ}\text{C}/\text{W}$

Electrical Characteristics (100% Tested)

Characteristic	Conditions	Symbol	Min	Typ	Max	Units
Drain-Source Breakdown Voltage	$V_{GS} = 0\text{ V}, I_D = 5\text{ mA}$	$V_{(BR)DSS}$	65	—	—	Volts
Zero Gate Voltage Drain Current	$V_{DS} = 26\text{ V}, V_{GS} = 0\text{ V}$	I_{DSS}	—	—	1.0	mA
Gate Threshold Voltage	$V_{DS} = 10\text{ V}, I_D = 75\text{ mA}$	$V_{GS(th)}$	3.0	—	5.0	Volts
Forward Transconductance	$V_{DS} = 10\text{ V}, I_D = 2\text{ A}$	g_{fs}	—	0.8	—	Siemens

RF Specifications (100% Tested)

Characteristic	Symbol	Min	Typ	Max	Units
Gain ($V_{DD} = 26\text{ V}, P_{OUT} = 1\text{ W}, I_{DQ} = 70\text{ mA}, f = 1.93, 1.99\text{ GHz}$)	G_{ps}	11	—	—	dB
Power Output at 1 dB Compression ($V_{DD} = 26\text{ V}, I_{DQ} = 70\text{ mA}, f = 1.99\text{ GHz}$)	P-1dB	5	—	—	Watts
Drain Efficiency ($V_{DD} = 26\text{ V}, P_{OUT} = 5\text{ W}, I_{DQ} = 70\text{ mA}, f = 1.99\text{ GHz}$)	η_D	40	—	—	%
Load Mismatch Tolerance ($V_{DD} = 26\text{ V}, P_{OUT} = 5\text{ W}, I_{DQ} = 70\text{ mA}, f = 1.99\text{ GHz}$ —all phase angles at frequency of test)	Ψ	—	—	10:1	—

Typical Performance

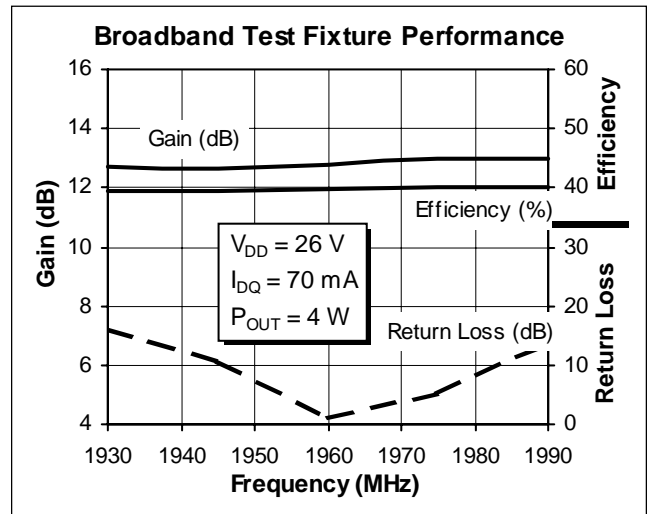
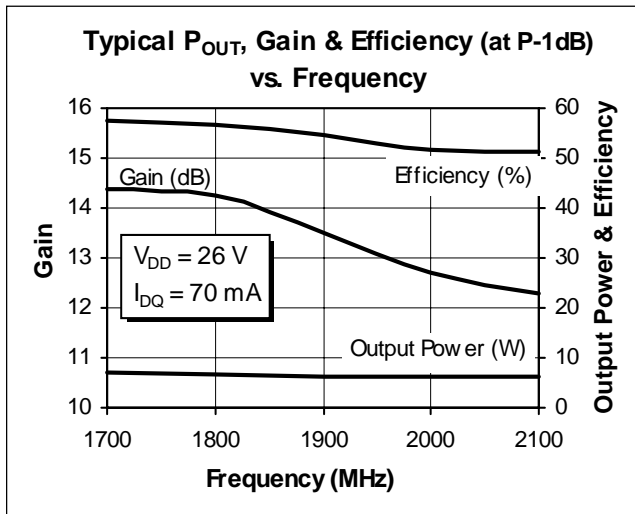

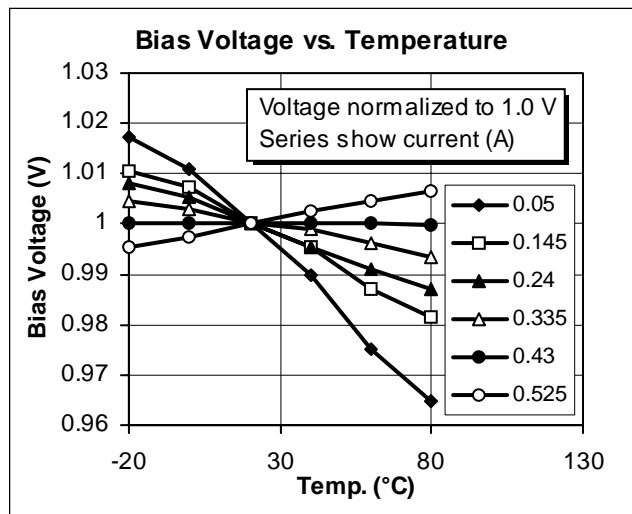
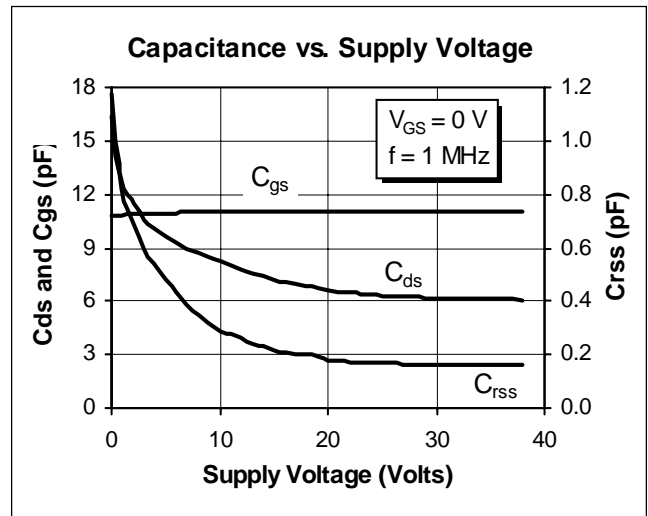
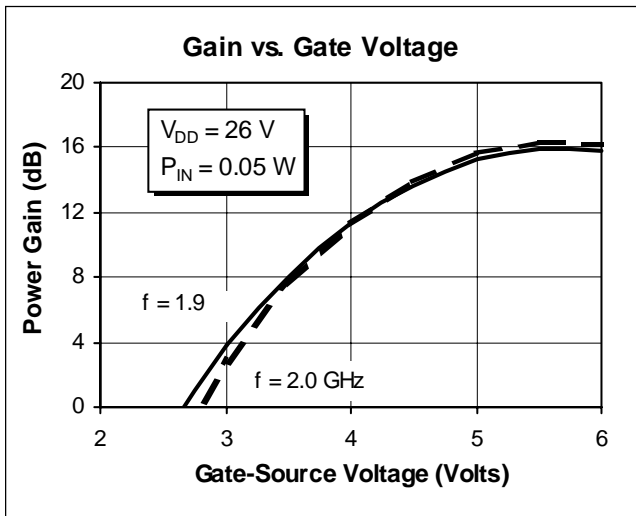
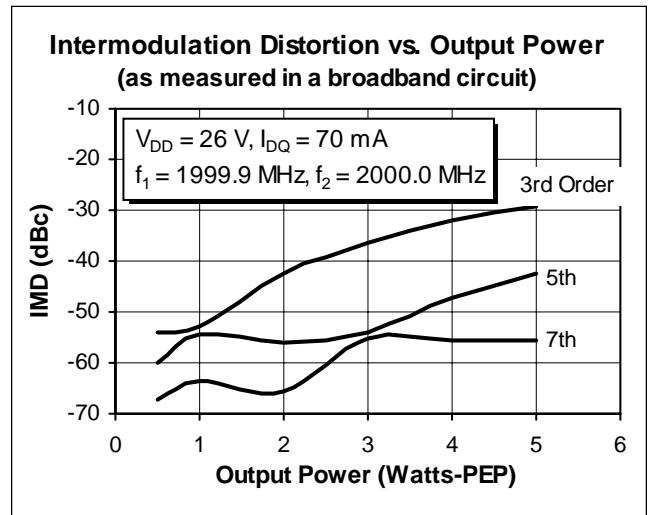
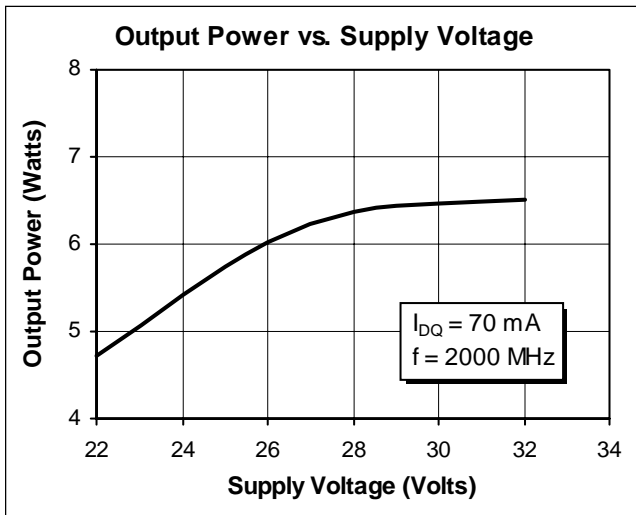

PTF 10135



Impedance Data

$V_{DD} = 26\text{ V}$, $P_{OUT} = 5\text{ W}$, $I_{DQ} = 70\text{ mA}$

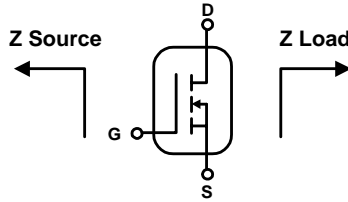

Frequency GHz	Z Source Ω		Z Load Ω	
	R	jX	R	jX
1.7	5.3	-2.9	8.0	3.0
1.8	3.3	-4.6	7.0	2.5
1.9	2.8	-5.0	6.0	1.2
2.0	2.6	-5.3	5.8	0.6
2.1	2.1	-6.0	5.7	-0.6

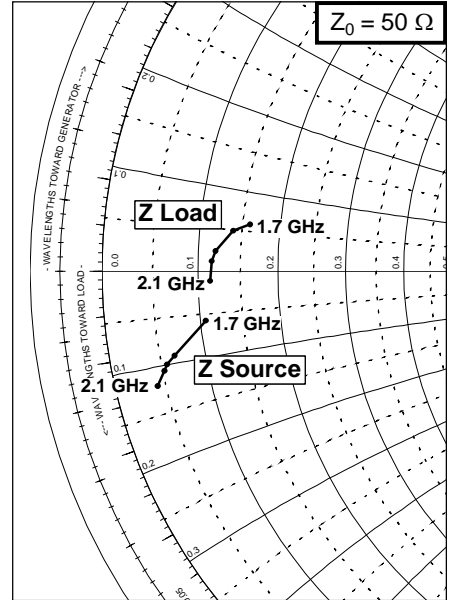

Typical Scattering Parameters

($V_{DS} = 26\text{ V}$, $I_{DQ} = 300\text{ mA}$)

f (MHz)	S11		S21		S12		S22	
	Mag	Ang	Mag	Ang	Mag	Ang	Mag	Ang
100	0.874	-58	24.1	137	0.009	46	0.770	-35
400	0.889	-115.5	12.707	89.0	0.016	9.1	0.759	-73.3
500	0.892	-128.2	10.388	76.6	0.015	1.1	0.768	-83.2
600	0.897	-138.1	8.626	66.5	0.013	-5.3	0.798	-92.6
700	0.903	-148.6	7.283	54.4	0.011	-11.1	0.833	-103.7
800	0.860	-154.5	5.853	46.3	0.008	-14.7	0.825	-112.5
900	0.873	-159.3	4.977	39.6	0.006	2.4	0.837	-119.4
1000	0.873	-162.8	4.262	33.4	0.005	10.7	0.853	-126.7
1100	0.891	-166.9	3.736	27.5	0.004	42.5	0.861	-132.7
1200	0.890	-169.6	3.264	22.7	0.005	70.3	0.863	-137.9
1300	0.904	-173.1	2.911	17.1	0.007	82.9	0.875	-143.1
1400	0.896	-174.7	2.583	13.5	0.010	87.4	0.866	-146.7
1500	0.932	-177.4	2.395	8.3	0.013	87.3	0.896	-150.4
1600	0.932	179.2	2.155	3.6	0.015	88.4	0.905	-155.0
1700	0.950	175.8	1.988	-1.6	0.018	87.5	0.930	-158.7
1800	0.955	171.8	1.808	-6.4	0.021	84.4	0.944	-162.9
1900	0.959	167.4	1.656	-12.0	0.023	81.5	0.972	-167.9
2000	0.945	164.0	1.487	-16.2	0.026	78.8	0.955	-172.4
2100	0.946	160.4	1.354	-21.3	0.027	76.6	0.963	-176.8
2200	0.949	159.3	1.250	-24.5	0.030	72.6	0.948	-180.0
2300	0.953	156.3	1.152	-29.2	0.032	69.4	0.961	175.9
2400	0.946	155.4	1.050	-31.0	0.034	68.6	0.931	173.8

Test Circuit

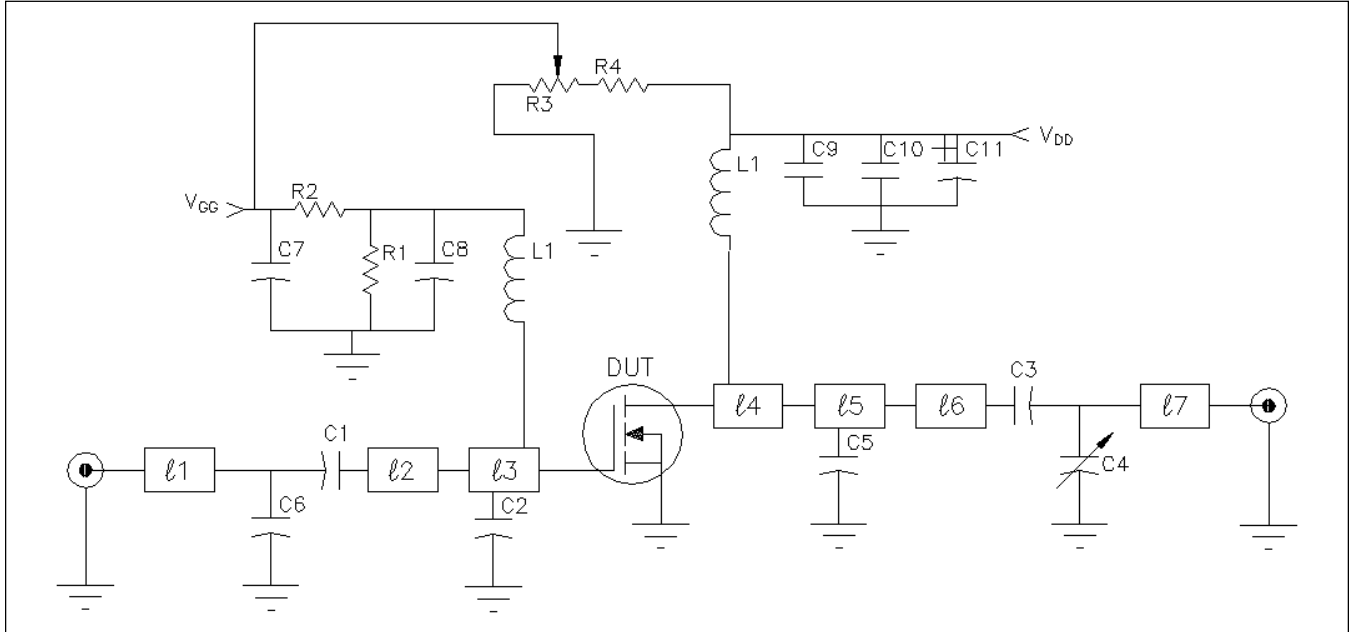

Block Diagram for $f = 1.96$ GHz

Q1	PTF 10135	LDMOS RF FET	C4	0.3–3.5 pF	Variable Capacitor
l1, l2, l7		Microstrip 50 Ω	C6	0.3 pF	Chip Cap
l3	0.149 λ 1.96 GHz	Microstrip 10.4 Ω	C7, C10	0.1 μ F	Chip Cap
l4	0.081 λ 1.96 GHz	Microstrip 15.9 Ω	C11	10 μ F	SMT Tantalum
l5	0.073 λ 1.96 GHz	Microstrip 12.1 Ω	L1, L2	4 Turn	#20 AWG, .120" I.D.
l6	0.06 λ 1.96 GHz	Microstrip 15.9 Ω	R1, R2	220 Ω	Chip Resistor K1206
C1, C3, C8, C9	33 pF	Chip Cap	R3	2K	SMT Potentiometer
C2, C5	0.7 pF	Chip Cap	R4	10 Ω	Chip Resistor K1206
			Circuit Board	.028" Dielectric Thickness, $\epsilon_r = 4.0$, AlliedSignal, G200, 2 oz. copper	

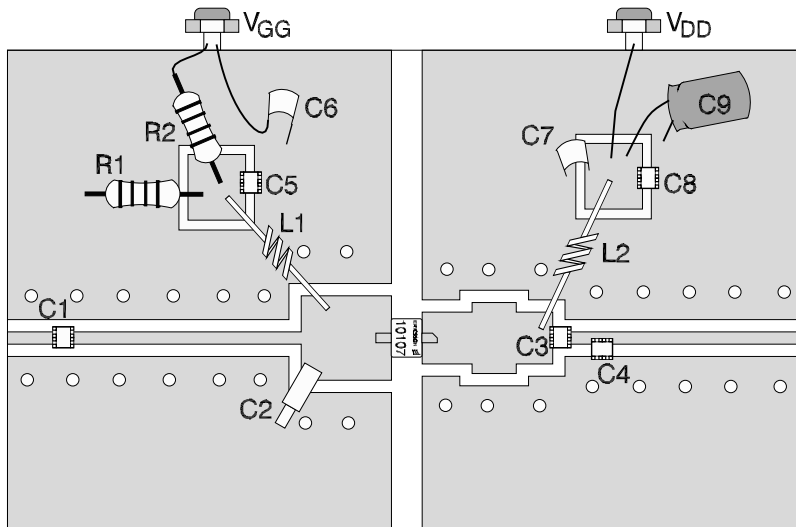

Parts Layout (not to scale)

PTF 10135

ERICSSON 

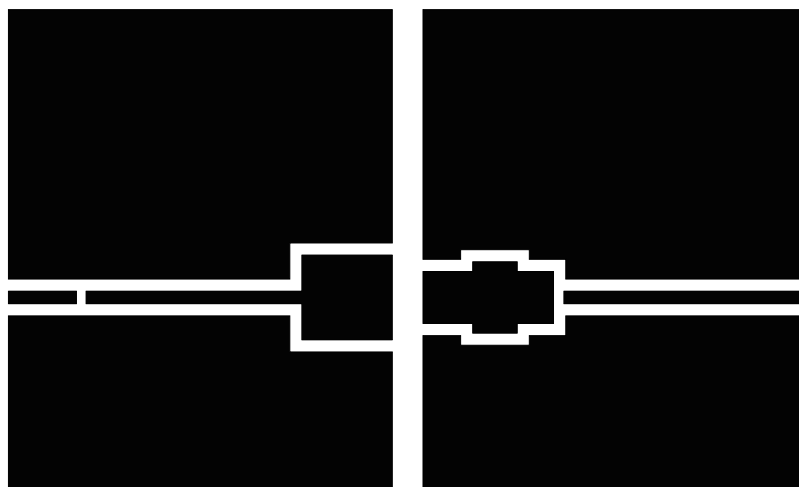

Artwork (1 inch  *)*