

DATA SHEET

PTN3501

Maintenance and control device

Product specification
Supersedes data of 2000 Nov 22

2001 Jan 17

Maintenance and control device

PTN3501

FEATURES

- I²C to parallel port expander
- Internal 256x8 E²PROM
- Self timed write cycle (5 ms typ.)
- 16 byte page write operation
- Controlled pull-up on address lines
- Low voltage V_{CC} range of +2.5 V to +3.6 V
- 5 V – tolerant I/Os
- Low standby current (< 60 μA)
- Power on Reset
- Supports Live Insertion
- Compatible with SMBus specification version 1.1
- High E²PROM endurance and data retention
- Available in TSSOP20 package

DESCRIPTION

The PTN3501 is a general purpose maintenance and control device. It features an on-board E²PROM that can be used to store error codes or board manufacturing data for read-back by application software for diagnostic purposes.

The eight quasi bidirectional data pins can be independently assigned as inputs or outputs to monitor board level status or activate indicator devices such as LEDs.

The PTN3501 has six address pins allowing up to 64 devices to share the common two wire I²C software protocol serial data bus.

The PTN3501 supports live insertion to facilitate usage in removable cards on backplane systems.

The PTN3501 is an alternative to the functionally similar PTN3500 for systems where a high number of devices are required to share the same I²C-bus without need for an additional I²C-bus I/O expander.

PIN CONFIGURATION

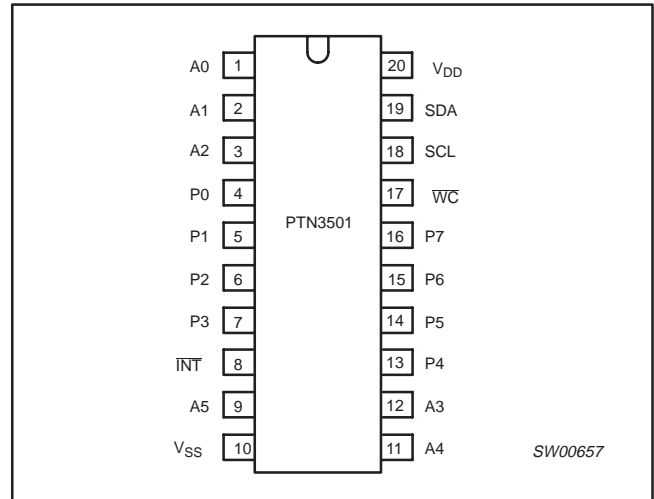

Figure 1.

PIN DESCRIPTION

PIN NUMBER	SYMBOL	NAME AND FUNCTION
1,2,3,9,11,12	A0:5	Address Lines
4,5,6,7	P0:3	Quasi-bidirectional I/O pins
10	V _{SS}	Ground
13,14,15,16	P4:7	Quasi-bidirectional I/O pins
17	WC	Write Control Pin. Should be tied LOW.
8	INT	Interrupt Pin
18	SCL	I ² C Serial Clock
19	SDA	I ² C Serial Data
20	V _{DD}	Supply Voltage

ORDERING INFORMATION

Type number	Package		
	Name	Description	Version
PTN3501DH	TSSOP20	Plastic thin shrink small-outline package; 20 leads; body width 4.4 mm	SOT360-1

FUNCTIONAL DIAGRAM

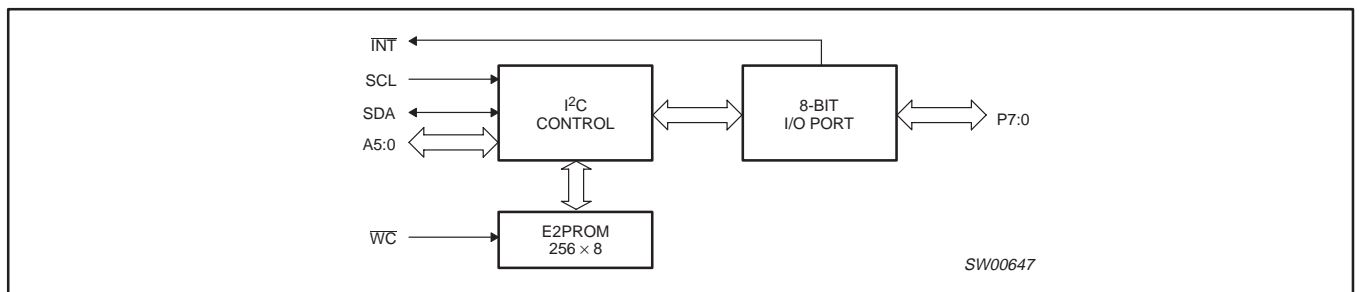

Figure 2.

Maintenance and control device

PTN3501

CHARACTERISTICS OF THE I²C-BUS

The I²C-bus is for 2-way, 2-line communication between different ICs or modules. The two lines are a serial data line (SDA) and a serial clock line (SCL). Both lines must be connected to a positive supply via a pull-up resistor when connected to the output stages of a device. Data transfer may be initiated only when the bus is not busy.

Bit transfer

One data bit is transferred during each clock phase. The data on the SDA line must remain stable during the HIGH period of the clock pulse as changes in the data line at this time will be interpreted as control signals (See Figure 3).

Start and stop conditions

Both data and clock lines remain HIGH when the bus is not busy. A HIGH-to-LOW transition of the data line, while the clock is HIGH is defined as the start condition (S). A LOW-to-HIGH transition of the data line while the clock is HIGH is defined as the stop condition (P) (see Figure 4).

System configuration

A device generating a message is a "transmitter", a device receiving is the "receiver". The device that controls the message is the "master" and the devices which are controlled by the master are the "slaves" (see Figure 5).

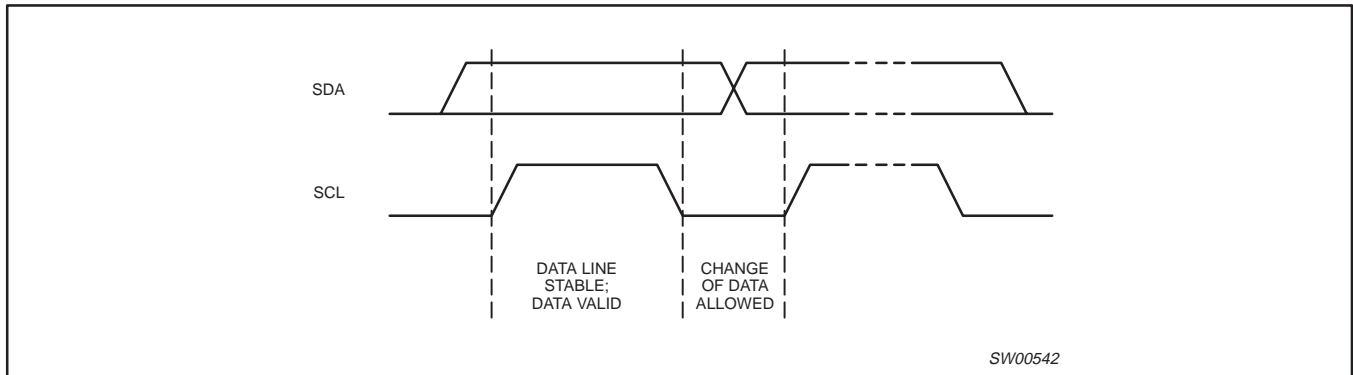

Figure 3. Bit transfer

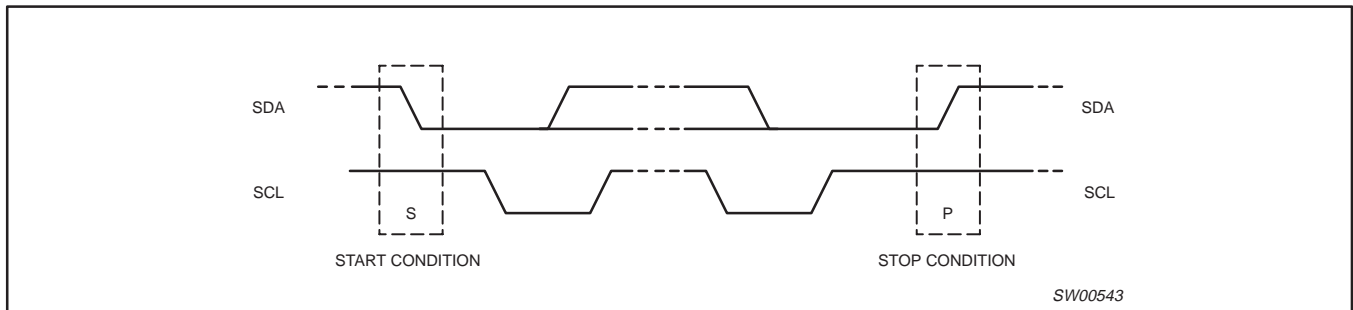

Figure 4. Definition of start and stop conditions

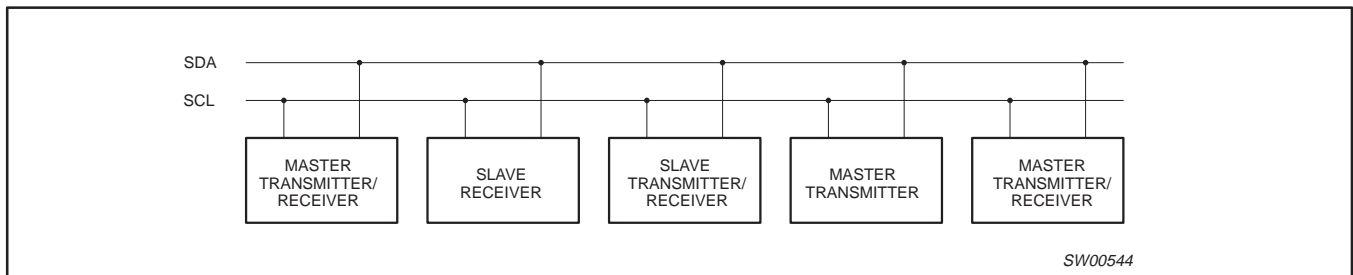

Figure 5. System configuration

Maintenance and control device

PTN3501

Acknowledge (see Figure 6)

The number of data bytes transferred between the start and the stop conditions from transmitter to receiver is not limited. Each byte of eight bits is followed by one acknowledge bit. The acknowledge bit is a HIGH level put on the bus by the transmitter whereas the master generates an extra acknowledge related clock pulse.

A slave receiver which is addressed must generate an acknowledge after the reception of each byte. Also a master must generate an acknowledge after the reception of each byte that has been clocked

out of the slave transmitter. The device that acknowledges has to pull down the SDA line during the acknowledge clock pulse, so that the SDA line is stable LOW during the HIGH period of the acknowledge related clock pulse, set-up and hold times must be taken into account.

A master receiver must signal an end of data to the transmitter by not generating an acknowledge on the last byte that has been clocked out of the slave. In this event the transmitter must leave the data line HIGH to enable the master to generate a stop condition.

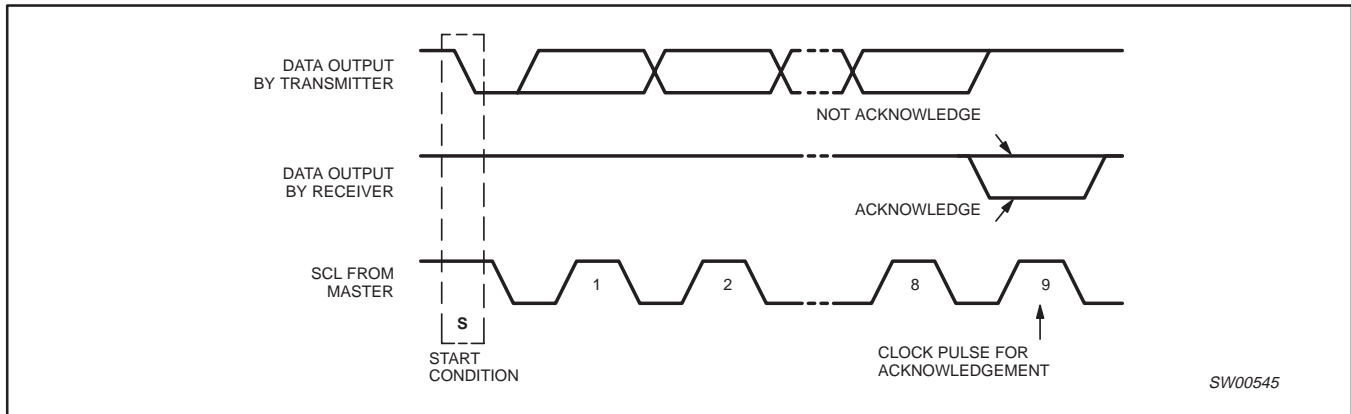

Figure 6. Acknowledgment on the I²C-bus

FUNCTIONAL DESCRIPTION

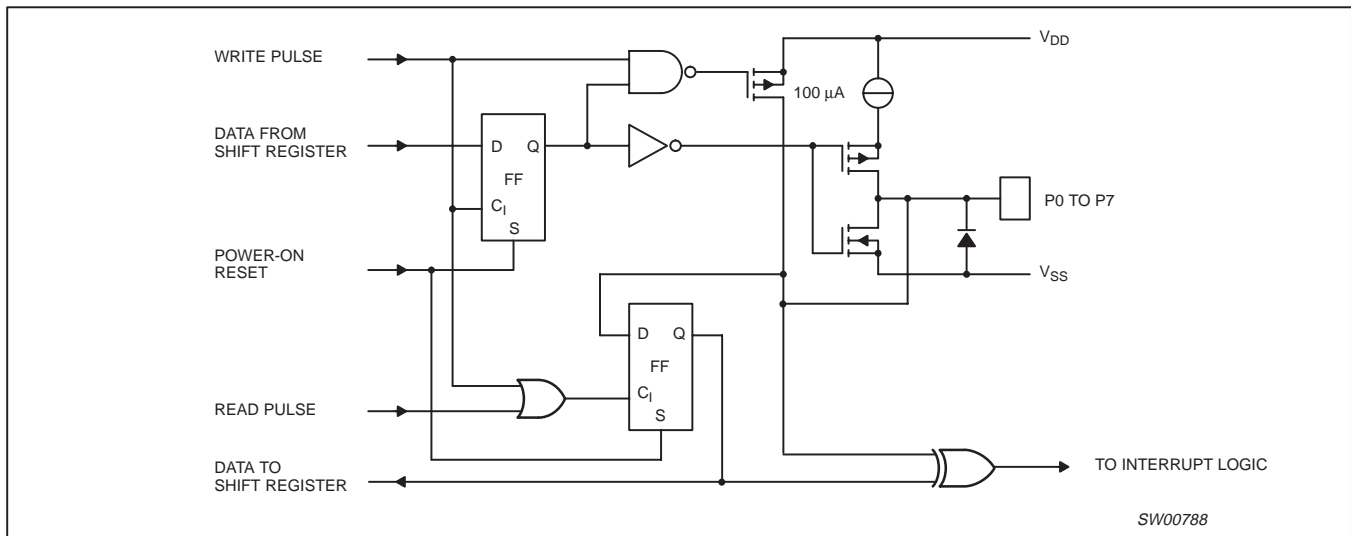

Figure 7. Simplified schematic diagram of each I/O

Maintenance and control device

PTN3501

Addressing

For addressing, see Figure 8.

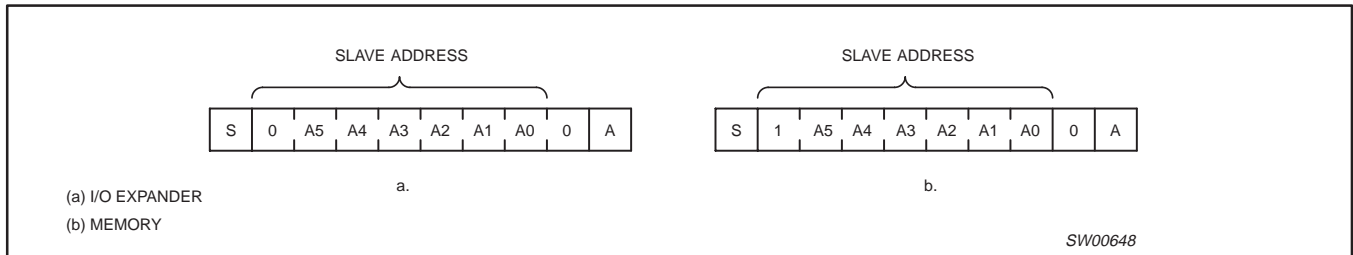

Figure 8. PTN3501 slave addresses

Asynchronous Start

Following any Start condition on the bus, a minimum of 9 SCL clock cycles must be completed before a Stop condition can be issued. The device does not support a Stop or a repeated Start condition during this time period.

I/O OPERATIONS (see also Figure 7)

Each of the PTN3501's eight I/Os can be independently used as an input or output. Input I/O data is transferred from the port to the microcontroller by the READ mode (See Figure 10). Output data is transmitted to the port by the I/O WRITE mode (see Figure 9).

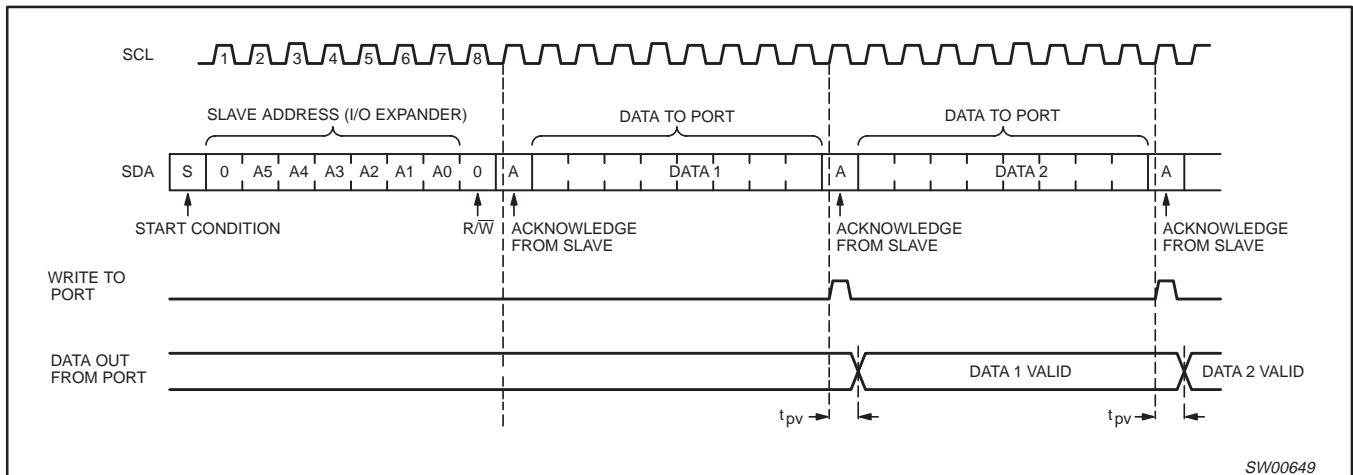

Figure 9. I/O WRITE mode (output)

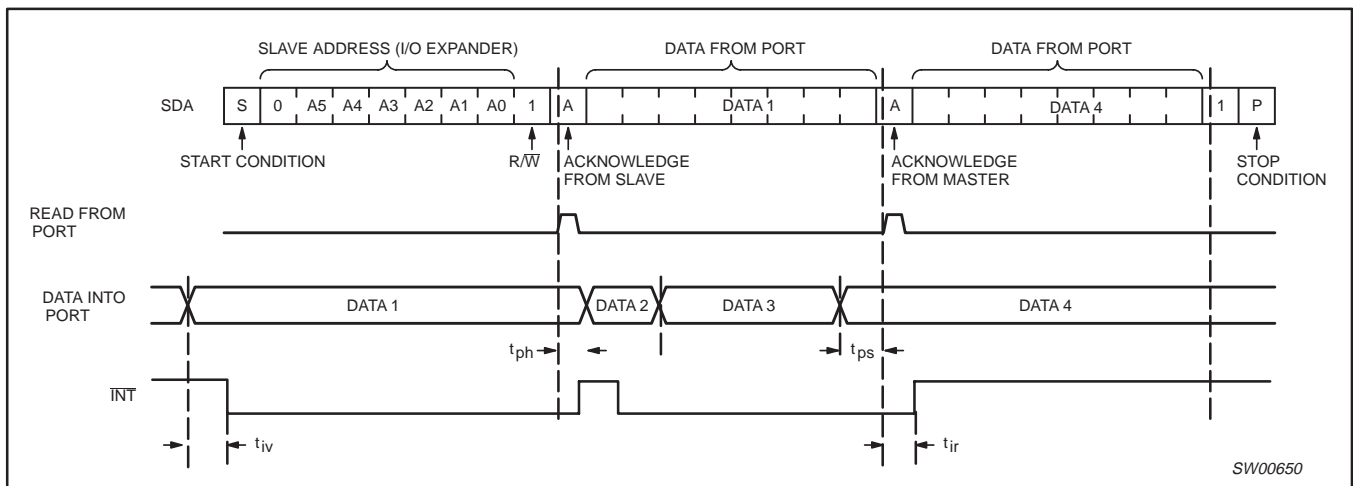

Figure 10. I/O READ mode (input)

Maintenance and control device

PTN3501

Interrupt (see Figs 11 and 12)

The PTN3501 provides an open drain output ($\overline{\text{INT}}$) which can be fed to a corresponding input of the microcontroller. This gives these chips a type of master function which can initiate an action elsewhere in the system.

An interrupt is generated by any rising or falling edge of the port inputs in the input mode. After time t_{iv} the signal $\overline{\text{INT}}$ is valid.

Resetting and reactivating the interrupt circuit is achieved when data on the port is changed to the original setting or data is read from or written to the port which has generated the interrupt.

Resetting occurs as follows:

- In the READ mode at the acknowledge bit after the rising edge of the SCL signal

- In the WRITE mode at the acknowledge bit after the HIGH-to-LOW transition of the SCL signal
- Returning of the port data to its original setting. A second port state change will require an SCL rising clock edge to be captured as an $\overline{\text{INT}}$ event.
- Interrupts which occur during the acknowledge clock pulse may be lost (or very short) due to the resetting of the interrupt during this pulse.

Each change of the I/Os after resetting will be detected and, after the next rising clock edge, will be transmitted as $\overline{\text{INT}}$. Reading from or writing to another device does not affect the interrupt circuit.

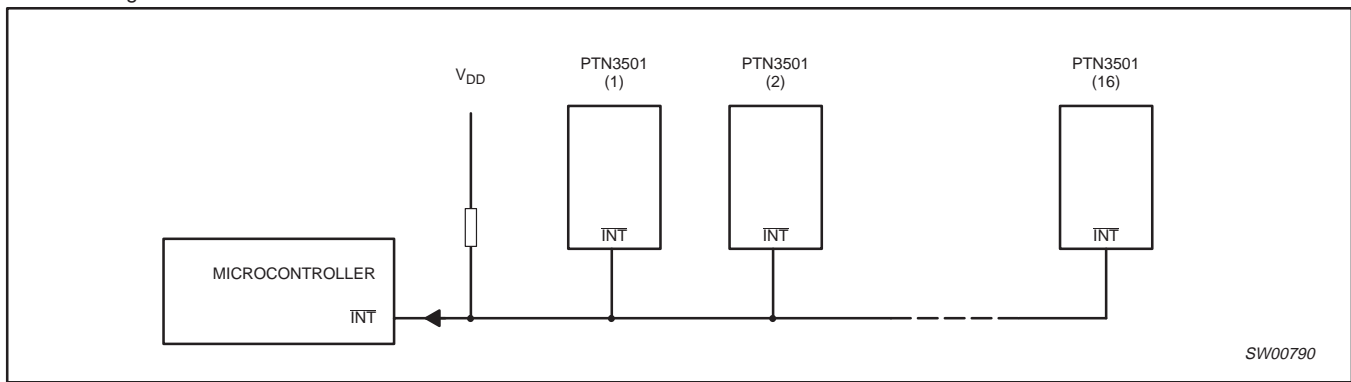

Figure 11. Application of multiple PTN3501s with interrupt

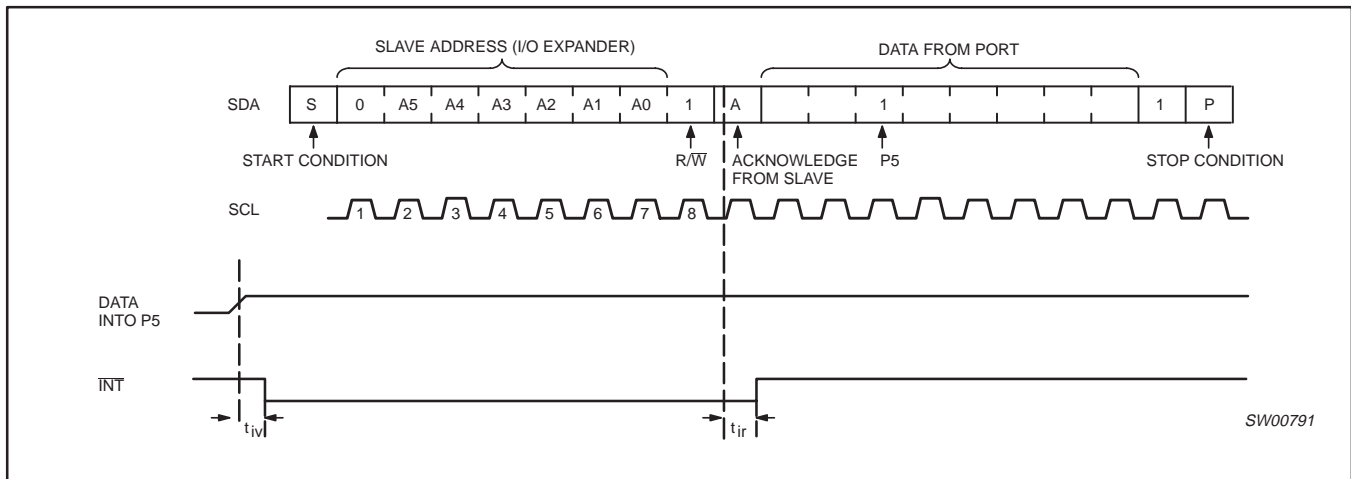

Figure 12. Interrupt generated by a change of input to I/O P5

Maintenance and control device

PTN3501

Quasi-bidirectional I/Os (see Figure 13)

A quasi-bidirectional I/O can be used as an input or output without the use of a control signal for data direction. At power-on the I/Os are HIGH. In this mode, only a current source to V_{DD} is active. An additional strong pull-up to V_{DD} allows fast rising edges into heavily loaded outputs. These devices turn on when an output is written HIGH, and are switched off by the negative edge of SCL. The I/Os should be HIGH before being used as inputs.

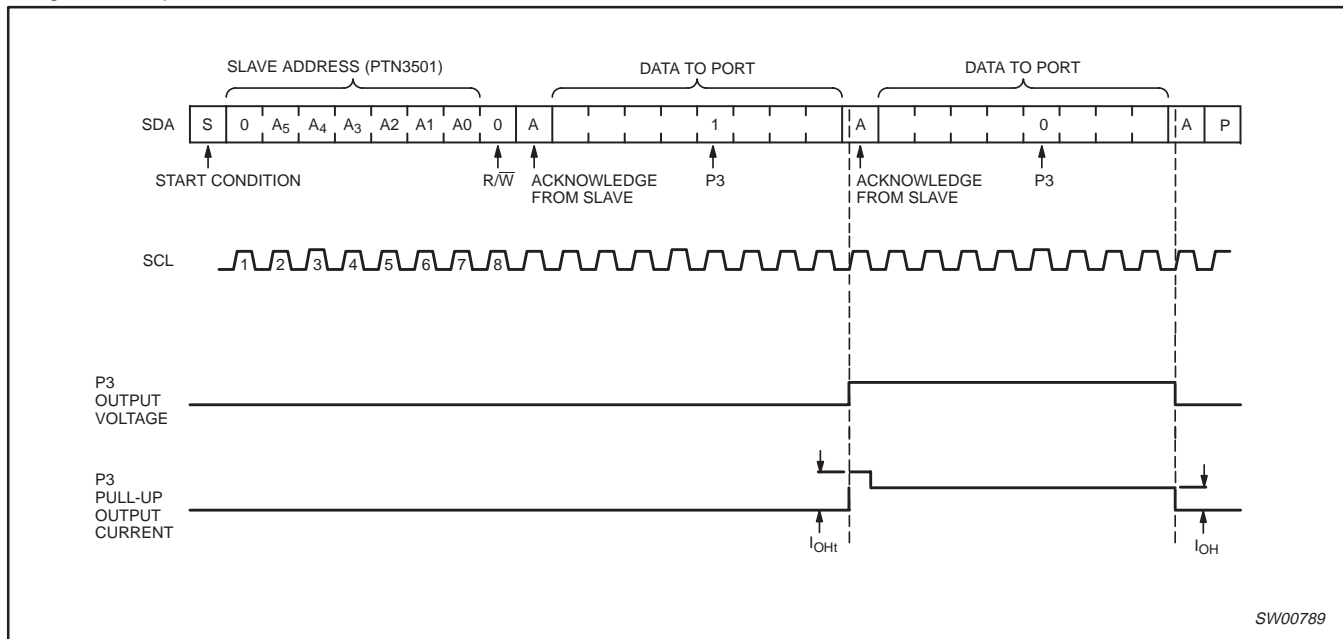

Figure 13. Transient pull-up current I_{OHt} while P3 changes from LOW-to-HIGH and back to LOW

SYMBOL	PARAMETER	MIN	TYP	MAX	UNIT
t_{pv}	Output data valid; $C_L \leq 100$ pF	–	–	4	μ S
t_{ps}	Input data setup time; $C_L \leq 100$ pF	0	–	–	μ S
t_{ph}	Input data hold time; $C_L \leq 100$ pF	4	–	–	μ S
t_{iv}	Interrupt input data valid time; $C_L \leq 100$ pF	–	–	4	μ S
t_{ir}	Interrupt reset time; $C_L \leq 100$ pF	–	–	4	μ S

Maintenance and control device

PTN3501

MEMORY OPERATIONS

Write operations

Write operations require an additional address field to indicate the memory address location to be written. The address field is eight bits long providing access to any one of the 256 words of memory. There are two types of write operations, byte write and page write.

Byte Write (see Figure 14)

To perform a byte write the start condition is followed by the memory slave address and the R/\bar{W} bit set to 0. The PTN3501 will respond with an acknowledge and then consider the next eight bits sent as the word address and the eight bits after the word address as the data. The PTN3501 will issue an acknowledge after the receipt of both the word address and the data. To terminate the data transfer

the master issues the stop condition, initiating the internal write cycle to the non-volatile memory. Only write and read operations to the quasi-bidirectional I/Os are allowed during the internal write cycle.

Page Write (see Figure 15)

A page write is initiated in the same way as the byte write, if after sending the first word of data, the stop condition is not received the PTN3501 considers subsequent words as data. After each data word the PTN3501 responds with an acknowledge and the four least significant bits of the memory address field are incremented. Should the master not send a stop condition after 16 data words the address counter will return to its initial value and overwrite the data previously written. After the receipt of the stop condition the inputs will behave as with the byte write during the internal write cycle.

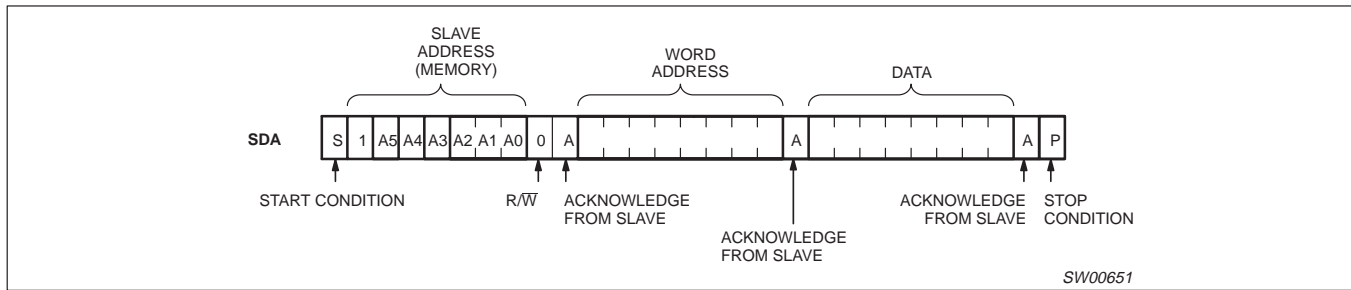

Figure 14. Byte write

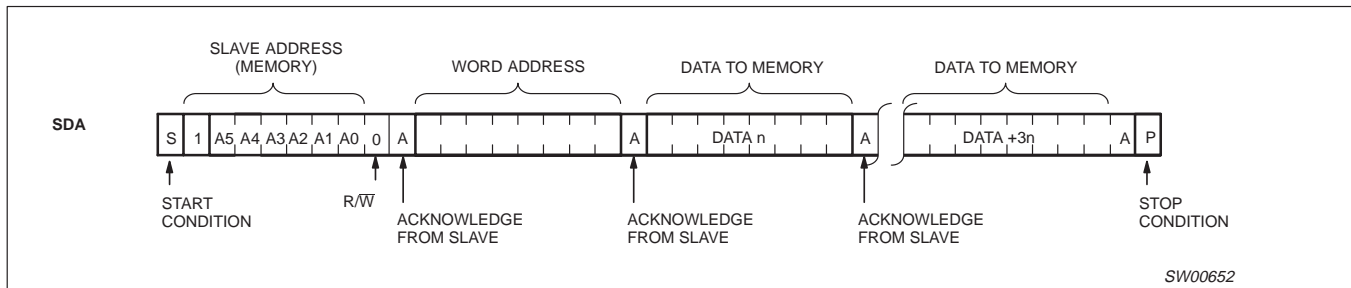

Figure 15. Page Write

Maintenance and control device

PTN3501

Read operations

PTN3501 read operations are initiated in an identical manner to write operations with the exception that the memory slave address' R/W bit is set to a one. There are three types of read operations; current address, random and sequential.

Current Address Read (see Figure 16)

The PTN3501 contains an internal address counter that increments after each read or write access, as a result if the last word accessed was at address n then the address counter contains the address n+1.

When the PTN3501 receives its memory slave address with the R/W bit set to one it issues an acknowledge and uses the next eight clocks to transmit the data contained at the address stored in the address counter. The master ceases the transmission by issuing the stop condition after the eighth bit. There is no ninth clock cycle for the acknowledge.

Random Read (see Figure 17)

The PTN3501's random read mode allows the address to be read from to be specified by the master. This is done by performing a dummy write to set the address counter to the location to be read.

The master must perform a byte write to the address location to be read, but instead of transmitting the data after receiving the acknowledge from the PTN3501 the master reissues the start condition and memory slave address with the R/W bit set to one. The PTN3501 will then transmit an acknowledge and use the next eight clock cycles to transmit the data contained in the addressed location. The master ceases the transmission by issuing the stop condition after the eighth bit, omitting the ninth clock cycle acknowledge.

Sequential Read (see Figure 18)

The PTN3501 sequential read is an extension of either the current address read or random read. If the master doesn't issue a stop condition after it has received the eighth data bit, but instead issues an acknowledge, the PTN3501 will increment the address counter and use the next eight cycles to transmit the data from that location. The master can continue this process to read the contents of the entire memory. Upon reaching address 255 the counter will return to address 0 and continue transmitting data until a stop condition is received. The master ceases the transmission by issuing the stop condition after the eighth bit, omitting the ninth clock cycle acknowledge.

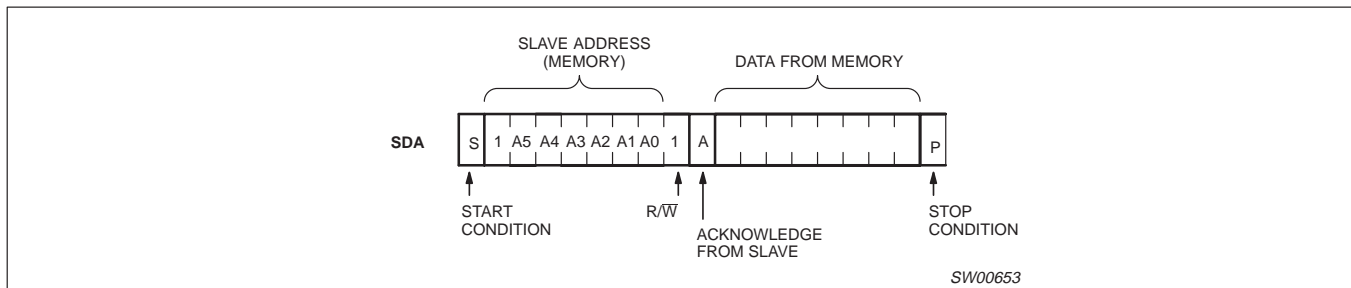

Figure 16. Current Address Read

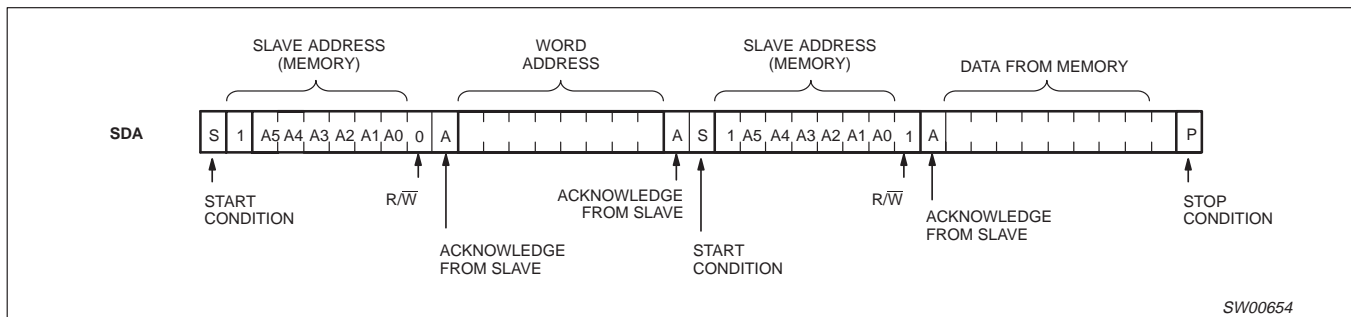

Figure 17. Random Read

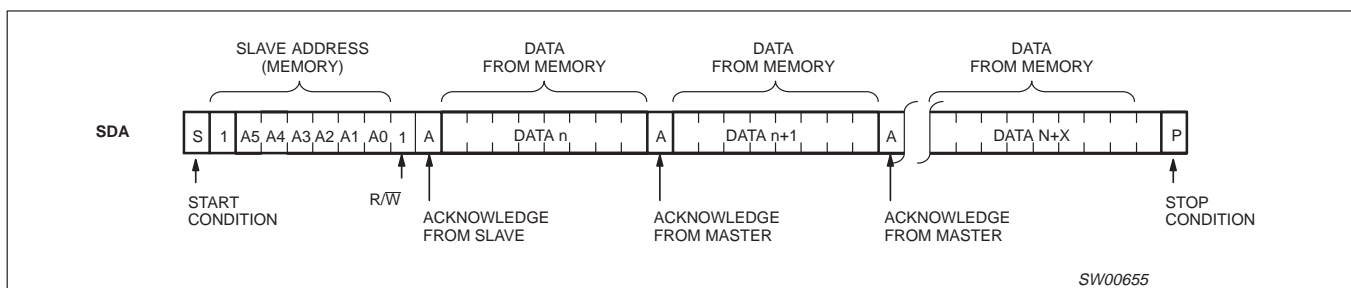

Figure 18. Sequential Read

Maintenance and control device

PTN3501

ABSOLUTE MAXIMUM RATINGS

Absolute Maximum Ratings are those values beyond which damage to the device may occur. Functional operation under these conditions is not implied.

SYMBOL	PARAMETER	MIN	MAX	UNIT
V _{CC}	Supply Voltage	-0.5	4.0	V
V _I	Input Voltage	V _{SS} - 0.5	5.5	V
I _I	DC Input Current	-20	20	mA
I _O	DC Output Current	-25	25	mA
I _{DD}	Supply Current	-100	100	mA
I _{SS}	Supply Current	-100	100	mA
P _{tot}	Total Power Dissipation	-	400	mW
P _O	Total Power Dissipation per Output	-	100	mW
T _{STG}	Storage Temperature	-65	+150	°C
T _{AMB}	Operating Temperature	-40	+85	°C
V _{ESD}	Electrostatic Discharge:			
	Human Body Model, 1.5 kΩ, 100 pF	-	>2000	V
	Machine Model, 0 Ω, 200 pF	-	>200	V

DC ELECTRICAL CHARACTERISTICST_{amb} = -40°C to +85°C unless otherwise specified; V_{CC} = 3.3 V

SYMBOL	PARAMETER	MIN	TYP	MAX	UNIT
Supply					
V _{DD}	Supply Voltage	2.5	3.3	3.6	V
I _{DDQ}	Standby Current; A ₀ thru A ₅ , \overline{WC} = HIGH	-		60	μA
I _{DD1}	Supply Current Read	-	-	1	mA
I _{DD2}	Supply Current Write	-	-	2	mA
V _{POR}	Power on Reset Voltage	-	-	2.4	V
Input SCL; input, output SDA					
V _{IL}	Input LOW voltage	-0.5	-	0.3 V _{DD}	V
V _{IH}	Input HIGH voltage	0.7 V _{DD}	-	5.5	V
I _{OL}	Output LOW current @ V _{OL} = 0.4 V	3	-	-	mA
I _L	Input leakage current @ V _I = V _{DD} or V _{SS}	-1	-	1	μA
C _I	Input capacitance @ V _I = V _{SS}	-	-	7	pF
I/O Expander Port					
V _{IL}	Input LOW voltage	-0.5	-	0.3 V _{DD}	V
V _{IH}	Input HIGH voltage	0.7 V _{DD}	-	5.5	V
I _{IHL(max)}	Input current through protection diodes	-400	-	400	μA
I _{OL}	Output LOW current @ V _{OL} = 1 V	10	25	-	mA
I _{OH}	Output HIGH current @ V _{OH} = V _{SS}	30	100	300	μA
I _{OHt}	Transient pull-up current	-	2	-	mA
C _I	Input Capacitance	-	-	10	pF
C _O	Output Capacitance	-	-	10	pF
Address Inputs A₀ thru A₅, \overline{WC} input					
V _{IL}	Input LOW voltage	-0.5	-	0.3 V _{DD}	V
V _{IH}	Input HIGH voltage	0.7 V _{DD}	-	5.5	V
I _L	Input leakage current @ V _I = V _{DD}	-1	-	1	μA
	Input leakage (pull-up) current @ V _I = V _{SS}	10	25	100	μA
Interrupt output INT					
I _{OL}	Low level output current; V _{OL} = 0.4 V	1.6	-	-	mA
I _L	Leakage current @ V _I = V _{DD} or V _{SS}	-1	-	+1	μA

Maintenance and control device

PTN3501

I²C-BUS TIMING CHARACTERISTICS

SYMBOL	PARAMETER	MIN.	TYP.	MAX.	UNIT
I²C-bus timing (see Figure 19; Note 1)					
f _{SCL}	SCL clock frequency	–	–	400	kHz
t _{SW}	tolerable spike width on bus	–	–	50	ns
t _{BUF}	bus free time	1.3	–	–	μs
t _{SU;STA}	START condition set-up time	0.6	–	–	μs
t _{HD;STA}	START condition hold time	0.6	–	–	μs
t _r	SCL and SDA rise time	–	–	0.3	μs
t _f	SCL and SDA fall time	–	–	0.3	μs
t _{SU;DAT}	data set-up time	250	–	–	ns
t _{HD;DAT}	data hold time	0	–	–	ns
t _{VD;DAT}	SCL LOW to data out valid	–	–	1.0	μs
t _{SU;STO}	STOP condition set-up time	0.6	–	–	μs

NOTE:

- All the timing values are valid within the operating supply voltage and ambient temperature range and refer to V_{IL} and V_{IH} with an input voltage swing of V_{SS} to V_{DD}.

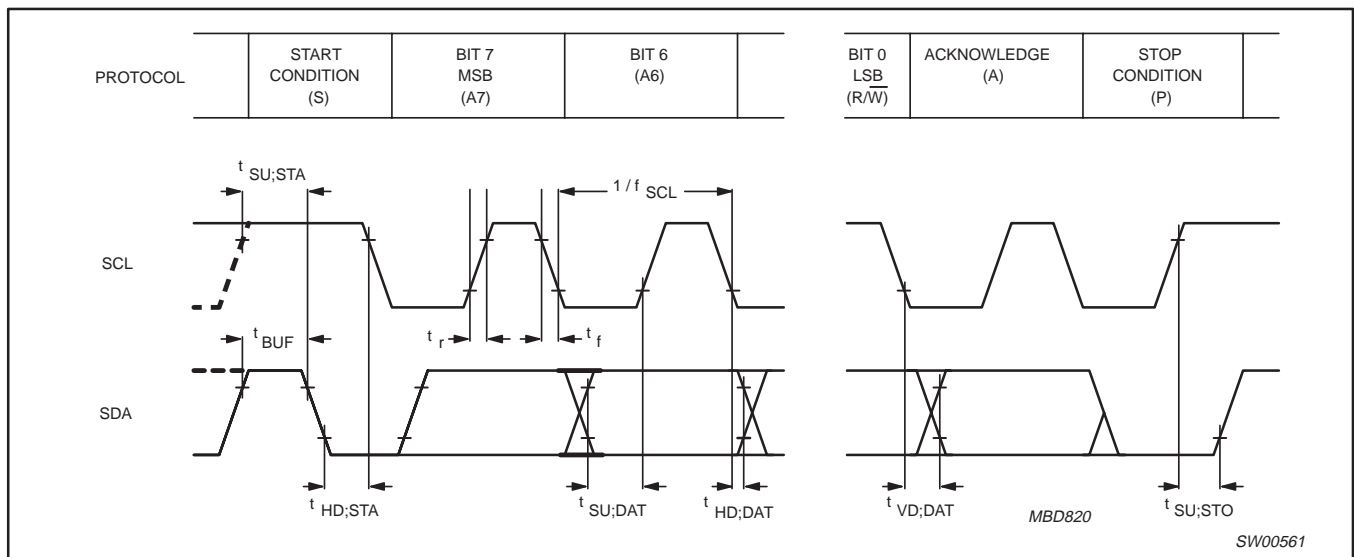

Figure 19.

Maintenance and control device

PTN3501

POWER-UP TIMING

SYMBOL	PARAMETER	MAX.	UNIT
t_{PUR}^1	Power-up to Read Operation	1	ms
t_{PUW}^1	Power-up to Write Operation	5	ms

NOTE:

- t_{PUR} and t_{PUW} are the delays required from the time V_{CC} is stable until the specified operation can be initiated. These parameters are guaranteed by design.

WRITE CYCLE LIMITS

SYMBOL	PARAMETER	MIN.	TYP. (5)	MAX.	UNIT
t_{WR}^1	Write Cycle Time	–	5	10	ms

NOTE:

- t_{WR} is the maximum time that the device requires to perform the internal write operation.

Write Cycle Timing

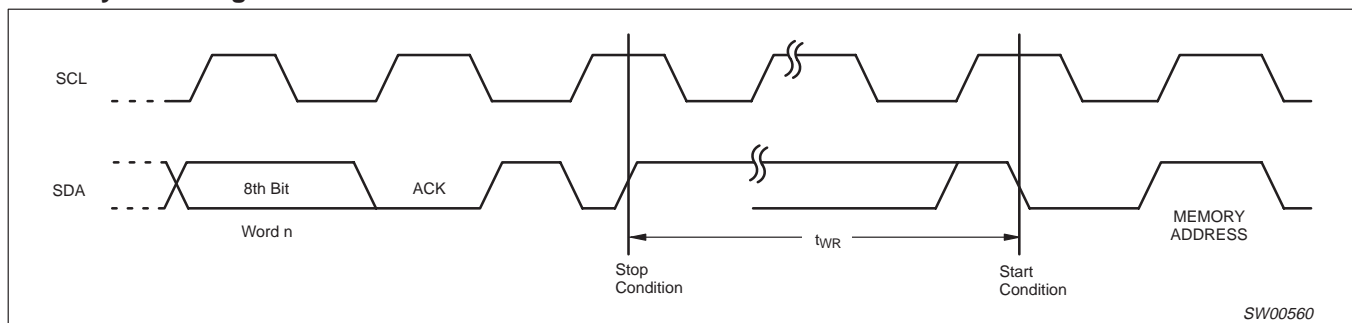

Figure 20.

SW00560

Maintenance and control device

PTN3501

SOLDERING

Introduction

There is no soldering method that is ideal for all IC packages. Wave soldering is often preferred when through-hole and surface mounted components are mixed on one printed-circuit board. However, wave soldering is not always suitable for surface mounted ICs, or for printed-circuits with high population densities. In these situations reflow soldering is often used.

This text gives a very brief insight to a complex technology. A more in-depth account of soldering ICs can be found in our *IC Package Databook* (order code 9398 652 90011).

DIP

Soldering by dipping or by wave

The maximum permissible temperature of the solder is 260°C; solder at this temperature must not be in contact with the joint for more than 5 seconds. The total contact time of successive solder waves must not exceed 5 seconds.

The device may be mounted up to the seating plane, but the temperature of the plastic body must not exceed the specified maximum storage temperature ($T_{stg\ max}$). If the printed-circuit board has been pre-heated, forced cooling may be necessary immediately after soldering to keep the temperature within the permissible limit.

Repairing soldered joints

Apply a low voltage soldering iron (less than 24 V) to the lead(s) of the package, below the seating plane or not more than 2 mm above it. If the temperature of the soldering iron bit is less than 300°C it may remain in contact for up to 10 seconds. If the bit temperature is between 300 and 400°C, contact may be up to 5 seconds.

SO and SSOP

Reflow soldering

Reflow soldering techniques are suitable for all SO and SSOP packages.

Reflow soldering requires solder paste (a suspension of fine solder particles, flux and binding agent) to be applied to the printed-circuit board by screen printing, stencilling or pressure-syringe dispensing before package placement.

Several techniques exist for reflowing; for example, thermal conduction by heated belt. Dwell times vary between 50 and 300

seconds depending on heating method. Typical reflow temperatures range from 215 to 250°C.

Preheating is necessary to dry the paste and evaporate the binding agent. Preheating duration: 45 minutes at 45°C.

Wave soldering

Wave soldering is not recommended for SSOP packages. This is because of the likelihood of solder bridging due to closely-spaced leads and the possibility of incomplete solder penetration in multi-lead devices.

If wave soldering cannot be avoided, the following conditions must be observed:

- **A double-wave (a turbulent wave with high upward pressure followed by a smooth laminar wave) soldering technique should be used.**
- **The longitudinal axis of the package footprint must be parallel to the solder flow and must incorporate solder thieves at the downstream end.**

Even with these conditions, only consider wave soldering SSOP packages that have a body width of 4.4 mm, that is SSOP16 (SOT369-1) or SSOP20 (SOT266-1).

During placement and before soldering, the package must be fixed with a droplet of adhesive. The adhesive can be applied by screen printing, pin transfer or syringe dispensing. The package can be soldered after the adhesive is cured.

Maximum permissible solder temperature is 260°C, and maximum duration of package immersion in solder is 10 seconds, if cooled to less than 150°C within 6 seconds. Typical dwell time is 4 seconds at 250°C.

A mildly-activated flux will eliminate the need for removal of corrosive residues in most applications.

Repairing soldered joints

Fix the component by first soldering two diagonally opposite end leads. Use only a low voltage soldering iron (less than 24 V) applied to the flat part of the lead. Contact time must be limited to 10 seconds at up to 300 °C. When using a dedicated tool, all other leads can be soldered in one operation within 2 to 5 seconds between 270 and 320°C.

PURCHASE OF PHILIPS I²C COMPONENTS



Purchase of Philips I²C components conveys a license under the Philips' I²C patent to use the components in the I²C system provided the system conforms to the I²C specifications defined by Philips. This specification can be ordered using the code 9398 393 40011.

Maintenance and control device

PTN3501

TSSOP20: plastic thin shrink small outline package; 20 leads; body width 4.4 mm

SOT360-1

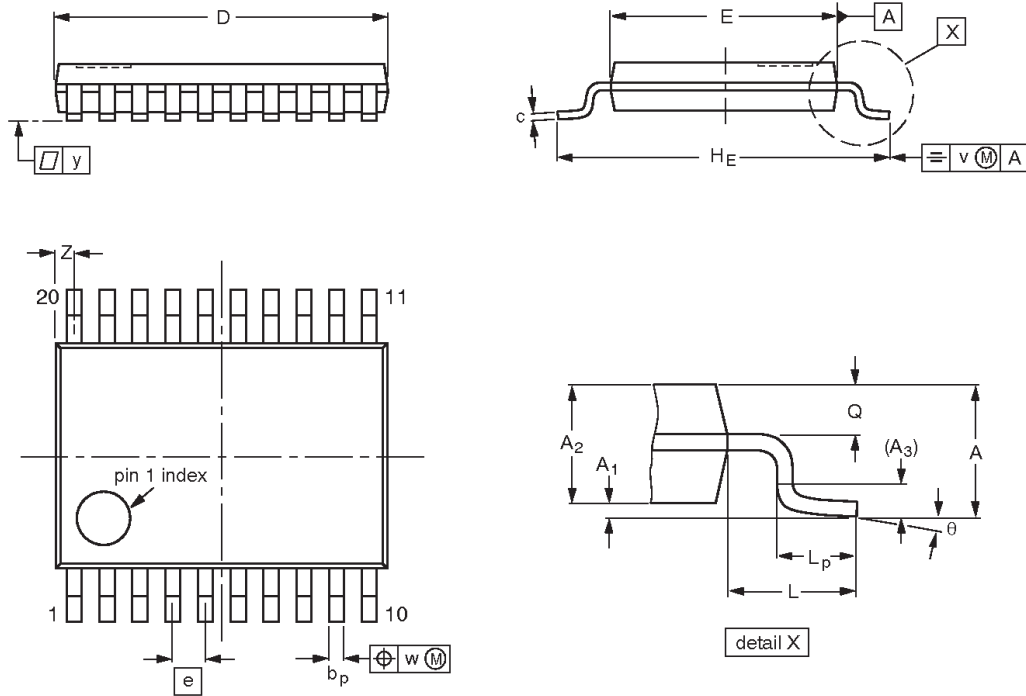

DIMENSIONS (mm are the original dimensions)

UNIT	A max.	A ₁	A ₂	A ₃	b _p	c	D ⁽¹⁾	E ⁽²⁾	e	HE	L	L _p	Q	v	w	y	Z ⁽¹⁾	θ
mm	1.10	0.15 0.05	0.95 0.80	0.25	0.30 0.19	0.2 0.1	6.6 6.4	4.5 4.3	0.65	6.6 6.2	1.0	0.75 0.50	0.4 0.3	0.2	0.13	0.1	0.5 0.2	8° 0°

Notes

1. Plastic or metal protrusions of 0.15 mm maximum per side are not included.
2. Plastic interlead protrusions of 0.25 mm maximum per side are not included.

OUTLINE VERSION	REFERENCES				EUROPEAN PROJECTION	ISSUE DATE
	IEC	JEDEC	EIAJ			
SOT360-1		MO-153				95-02-04 99-12-27

Maintenance and control device

PTN3501

Data sheet status

Data sheet status	Product status	Definition [1]
Objective specification	Development	This data sheet contains the design target or goal specifications for product development. Specification may change in any manner without notice.
Preliminary specification	Qualification	This data sheet contains preliminary data, and supplementary data will be published at a later date. Philips Semiconductors reserves the right to make changes at any time without notice in order to improve design and supply the best possible product.
Product specification	Production	This data sheet contains final specifications. Philips Semiconductors reserves the right to make changes at any time without notice in order to improve design and supply the best possible product.

[1] Please consult the most recently issued datasheet before initiating or completing a design.

Definitions

Short-form specification — The data in a short-form specification is extracted from a full data sheet with the same type number and title. For detailed information see the relevant data sheet or data handbook.

Limiting values definition — Limiting values given are in accordance with the Absolute Maximum Rating System (IEC 134). Stress above one or more of the limiting values may cause permanent damage to the device. These are stress ratings only and operation of the device at these or at any other conditions above those given in the Characteristics sections of the specification is not implied. Exposure to limiting values for extended periods may affect device reliability.

Application information — Applications that are described herein for any of these products are for illustrative purposes only. Philips Semiconductors make no representation or warranty that such applications will be suitable for the specified use without further testing or modification.

Disclaimers

Life support — These products are not designed for use in life support appliances, devices or systems where malfunction of these products can reasonably be expected to result in personal injury. Philips Semiconductors customers using or selling these products for use in such applications do so at their own risk and agree to fully indemnify Philips Semiconductors for any damages resulting from such application.

Right to make changes — Philips Semiconductors reserves the right to make changes, without notice, in the products, including circuits, standard cells, and/or software, described or contained herein in order to improve design and/or performance. Philips Semiconductors assumes no responsibility or liability for the use of any of these products, conveys no license or title under any patent, copyright, or mask work right to these products, and makes no representations or warranties that these products are free from patent, copyright, or mask work right infringement, unless otherwise specified.

Philips Semiconductors
811 East Arques Avenue
P.O. Box 3409
Sunnyvale, California 94088-3409
Telephone 800-234-7381

© Copyright Philips Electronics North America Corporation 2001
All rights reserved. Printed in U.S.A.

Date of release: 01-01

Document order number:

9397 750 07933

Let's make things better.