



PWS745

Multi-Channel Isolated DC/DC CONVERTER COMPONENTS

FEATURES

- COMPACT SIZE
- LOW COST PER CHANNEL
- DRIVES UP TO 8 CHANNELS
- 750/1500VAC ISOLATION
- FLEXIBLE USE WITH PWS740/PWS750 COMPONENTS
- 0.4 IN. MAXIMUM MOUNTING HEIGHT

APPLICATIONS

- INDUSTRIAL CONTROL
- GROUND-LOOP ELIMINATION
- PC-BASED DATA ACQUISITION
- POINT-OF-USE POWER CONVERSION
- 5V TO $\pm 15V$ FROM DIGITAL SUPPLIES

DESCRIPTION

The PWS745 is a set of components useful in the construction of single or multi-channel isolated DC/DC converters. By themselves, or in combination with the PWS740 and PWS750 families of components, they allow compact, optimal, and low-cost solutions to many power supply problems.

The PWS745-1 DIP oscillator/driver can be used to drive up to eight channels of independently isolated power. The switching MOSFETs are built into the driver to allow simple low-cost assembly of the multi-channel converter. The PWS745-1 also is capable of operating at 5VDC and can be easily synchronized with TTL level signals. While offering the user an alternative to the TO-3 package of the PWS740, the

PWS745-1 also allows the user to select varying levels of power, isolation voltage, mounting technology and system configuration by choosing among the several component families. For example, the PWS745-1 can directly drive the PWS740, PWS745, or PWS750 transformers. It also can drive the FETs of a PWS750 distributed power system. The operating frequency is compatible with the ISO120 family of isolation amplifiers and is capable of multi-channel synchronized operation to eliminate troublesome beat frequencies.

The PWS745-2 is a 15V to $\pm 15V$ output version, while the PWS745-4 is the 5V to $\pm 15V$ output version. The PWS740-3 high-speed bridge provides a convenient rectifier for the selected transformer output.

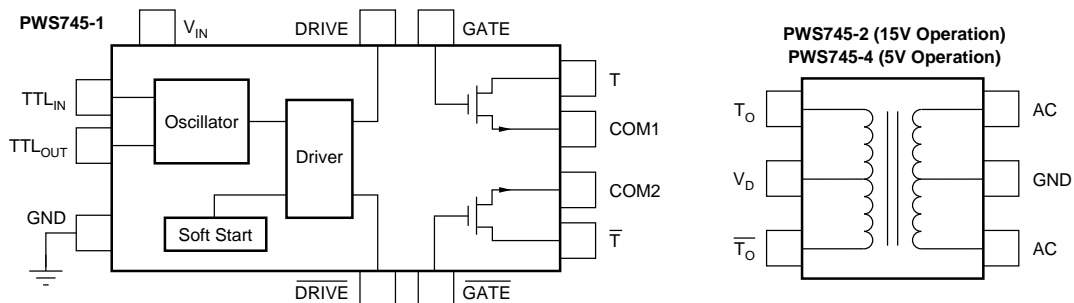

International Airport Industrial Park • Mailing Address: PO Box 11400 • Tucson, AZ 85734 • Street Address: 6730 S. Tucson Blvd. • Tucson, AZ 85706
Tel: (520) 746-1111 • Twx: 910-952-1111 • Cable: BBRCORP • Telex: 066-6491 • FAX: (520) 889-1510 • Immediate Product Info: (800) 548-6132

SPECIFICATIONS

ELECTRICAL

At $V_{IN} = 15VDC$, Output Load = $\pm 15mA$ (PWS745-2) and $T_A = 25^\circ C$ unless otherwise noted.
 Or $V_{IN} = 5VDC$, Output Load = $\pm 12mA$ (PWS745-4) and $T_A = 25^\circ C$ unless otherwise noted.

PARAMETER	CONDITIONS	MIN	TYP	MAX	UNITS
PWS745-1 OSCILLATOR/DRIVER					
Frequency: Internal OSC External OSC	$TTL_{IN} = 0V$	550 500	600 600	650 1000	kHz kHz
Supply: 15V Operation 5V Operation		10 4.5	15 5	18 5.5	V V
Current	No Load Max Load		10 650		mA mA
Current Ripple	$C_{BYPASS} = 1\mu F$		2.5		mAp-p
TTL_{IN} : I_{IH} I_{IL} V_{IH} V_{IL}			-1	10	nA μA V V
Frequency		1		0.8 2	V MHz
TTL_{OUT} : I_{OL} Frequency			600	15	mA kHz
T, \bar{T} Drive Current				50	mA
T, \bar{T} Drive Voltage: High Low		3		7 0.7	V V
PWS745-2					
Voltage, Rated Continuous AC 60Hz 100% Test ⁽¹⁾	60Hz, 1s	750 1200			Vrms Vrms
Barrier Impedance Leakage Current at 60Hz	$V_{ISO} = 240Vrms, 60Hz$		$10^{12} \parallel 8$	150	$\Omega \parallel pF$ $\mu Arms$
PWS745-4					
Voltage, Rated Continuous AC 60Hz 100% Test ⁽¹⁾	60Hz, 1s	750 1200			Vrms Vrms
Barrier Impedance Leakage Current at 60Hz	$V_{ISO} = 240Vrms, 60Hz$		$10^{12} \parallel 8$	150	$\Omega \parallel pF$ $\mu Arms$
TEMPERATURE RANGE					
Specification		-40		85	$^\circ C$
Operation		-40		85	$^\circ C$
Storage		-40		85	$^\circ C$

NOTES: (1) Tested at 1.6 rated, fail on 5pc partial discharge leakage current on five successive pulses.

The information provided herein is believed to be reliable; however, BURR-BROWN assumes no responsibility for inaccuracies or omissions. BURR-BROWN assumes no responsibility for the use of this information, and all use of such information shall be entirely at the user's own risk. Prices and specifications are subject to change without notice. No patent rights or licenses to any of the circuits described herein are implied or granted to any third party. BURR-BROWN does not authorize or warrant any BURR-BROWN product for use in life support devices and/or systems.

ABSOLUTE MAXIMUM RATINGS

Supply Voltage	18V
Continuous Isolation Voltage	750Vrms
Junction Temperature	150°C
Storage Temperature	85°C
Lead Temperature (soldering, 10s)	300°C
Transformer Output Short to Common	Continuous
Max Load, Sum of All Transformer Outputs	500mA

Stresses above these ratings may permanently damage the device.

PACKAGE INFORMATION⁽¹⁾

MODEL	PACKAGE	PACKAGE DRAWING NUMBER
PWS745-1	16-Pin Plastic DIP	129
PWS745-2	8-Pin Plastic	250
PWS745-4	8-Pin Plastic	250

NOTE: (1) For detailed drawing and dimension table, please see end of data sheet, or Appendix D of Burr-Brown IC Data Book.



ELECTROSTATIC DISCHARGE SENSITIVITY

Electrostatic discharge can cause damage ranging from performance degradation to complete device failure. Burr-Brown Corporation recommends that all integrated circuits be handled and stored using appropriate ESD protection methods.

PIN CONFIGURATIONS

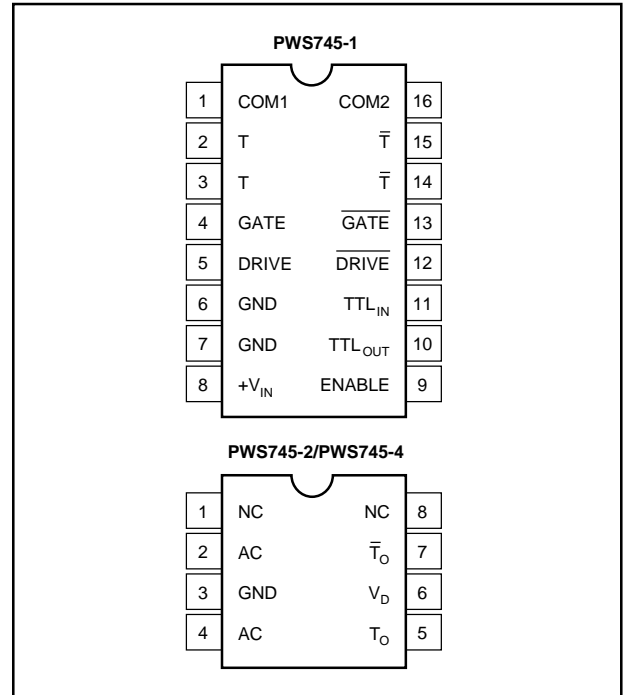

TYPICAL PERFORMANCE CURVES

$T_A = 25^\circ\text{C}$, +15VDC or +5VDC unless otherwise specified.

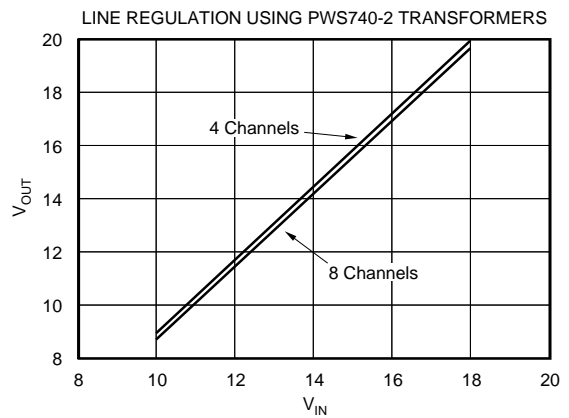
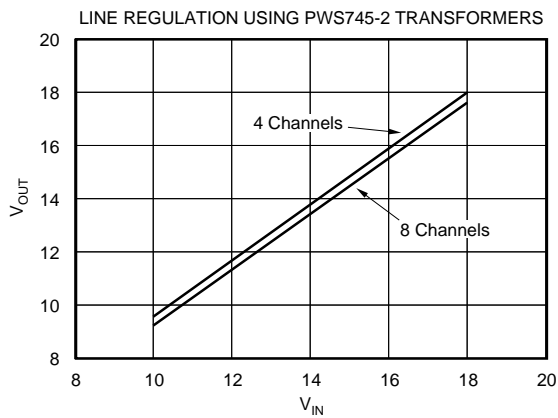
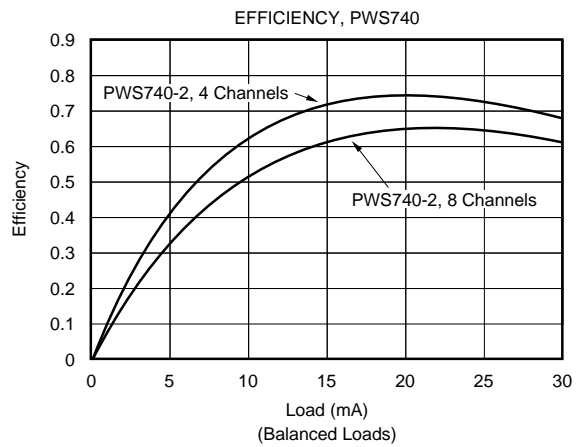
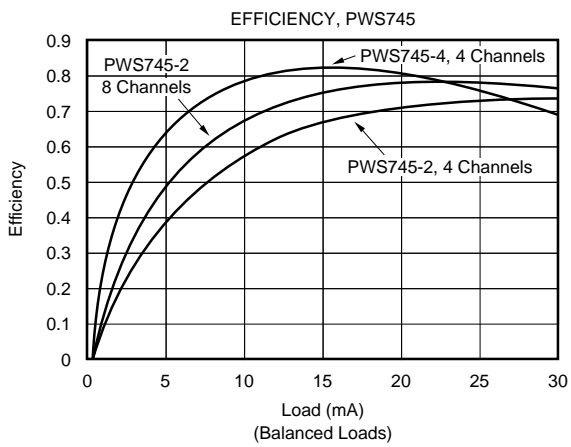
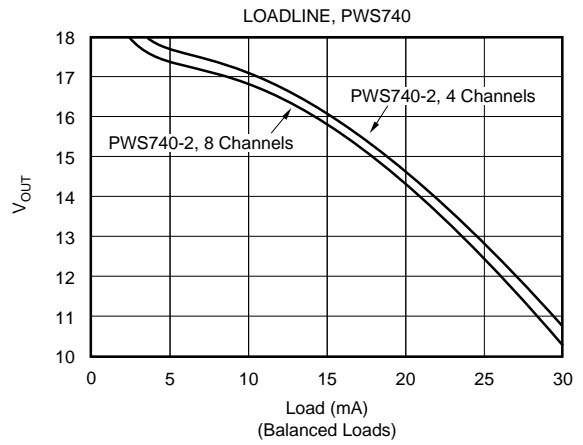
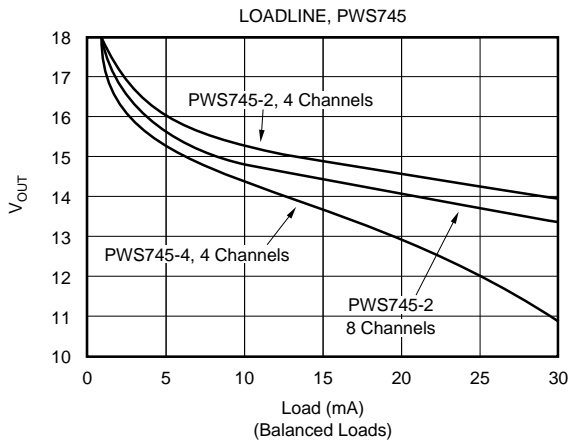

TYPICAL PERFORMANCE CURVES (CONT)

$T_A = 25^\circ\text{C}$, +15VDC or +5VDC unless otherwise specified.

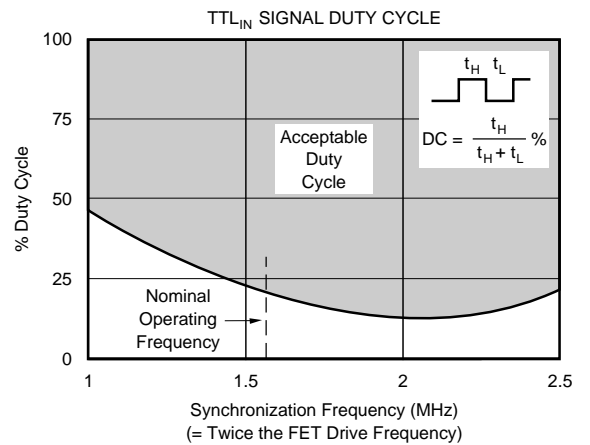
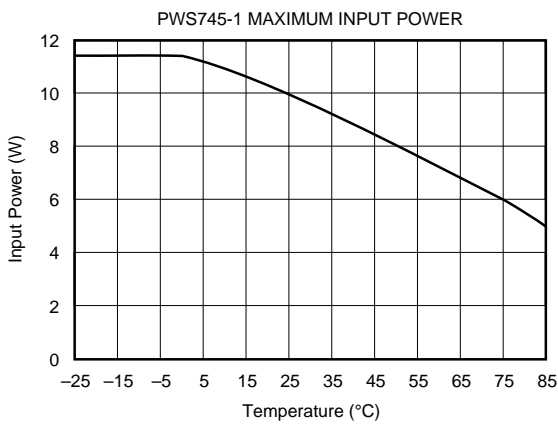
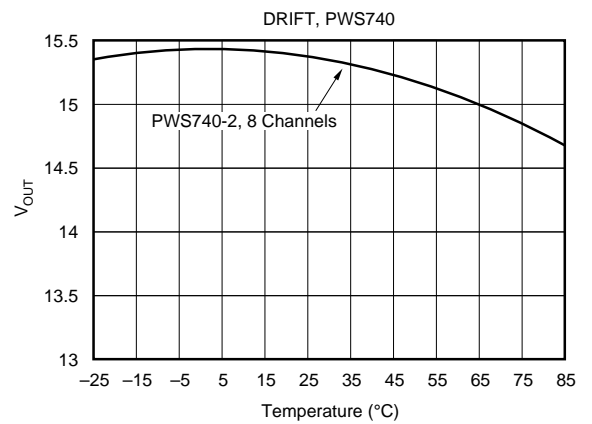
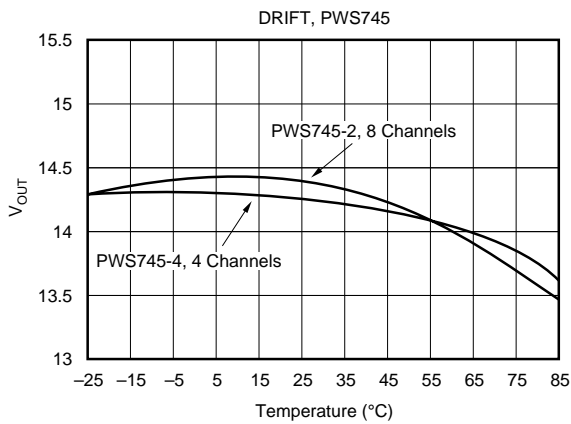
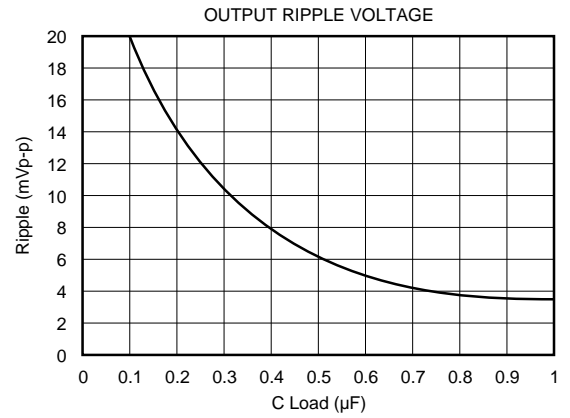
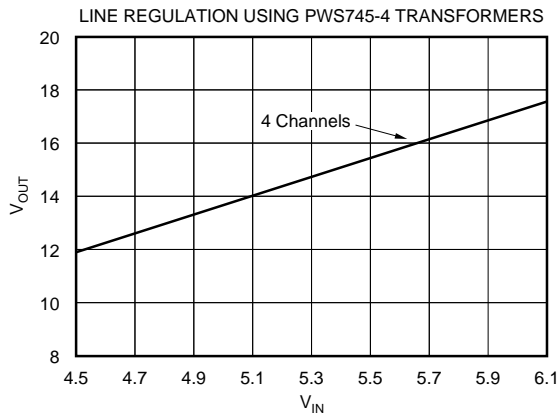

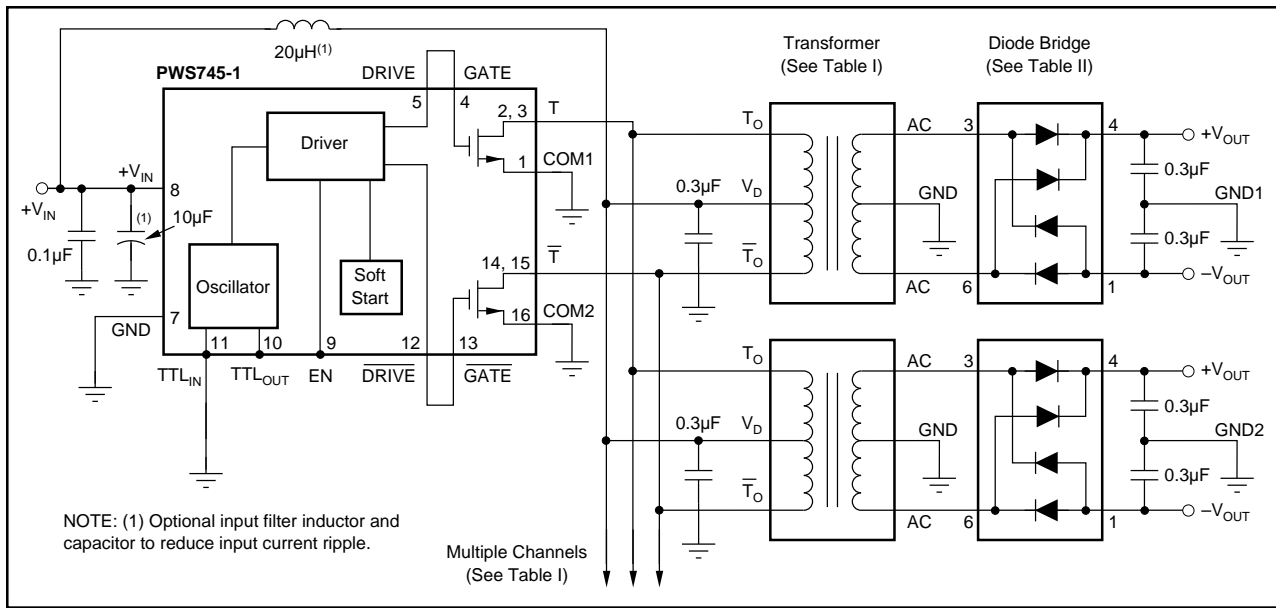

FIGURE 1. Typical Connections.

BASIC OPERATION

The PWS745 components are used to build a multichannel DC/DC converter. The oscillator runs at 600kHz nominal, making it possible to reduce the size of the transformer and lower the output ripple voltage. The PWS745-1 is a power oscillator/switch able to directly drive the primary side of an isolation transformer. The small size of the driver is achieved by using a multiple chip transfer molding process. The power components are mounted directly on the copper leadframe, utilizing two pins directly connected to each die pad to maximize heat sink area. The output of the transformer is rectified with a high speed diode bridge. The PWS740-2 is used when 1500Vrms isolation is required. The PWS745-2 or PWS750-2 is used when 750Vrms isolation is required. With these transformers, the output voltages directly track the input voltage. The PWS745-4 or PWS750-4 is used to step up the input voltage from 5V to $\pm 15V$. Operation at 5V makes it possible to build an isolated system for powering the analog components when only a logic supply is available. Using the PWS745-2 or -4 allows the user 0.5in. PCB spacing. The possible component combinations are summarized in Figure 1 and Tables I and II. The 600kHz operating frequency enables direct synchronization with products such as the ISO120 and ISO121. See Figure 3. The use of synchronization makes it possible to eliminate any power-supply induced ripple in the output of the isolation amplifiers and to minimize beats falling in the signal path bandwidth.

PIN DESCRIPTIONS

+V_{IN} AND GND

The +V_{IN} pin supplies power to the oscillator. The GND pins are used for the return currents of the driver chip.

TRANSFORMER	ISOLATION	CHANNELS	I/O	TECHNOLOGY
PWS745-2	750VAC	8	1:1	Thru-hole
PWS745-4	750VAC	4	1:3	Thru-hole
PWS740-2	1500VAC	8	1:1	Thru-hole
PWS750-2U	750VAC	8	1:1	Surface-mount
PWS750-4U	750VAC	4	1:3	Surface-mount

TABLE I.

DIODE BRIDGE	TECHNOLOGY
PWS740-3	Thru-hole
PWS750-3U	Surface-mount

TABLE II.

COM1, COM2

The COM pins are connected to the sources of the internal MOSFETs and each pin must be tied to ground. The current from the primary windings of the transformers flows in through the T and \bar{T} pins and then out through the COM pins.

TTL_{IN}

This pin must be tied to ground, except when it is desired to control the driver frequency with an external TTL level frequency source. The duty cycle can vary from 12% to 95% (see Typical Performance Curves). The input frequency must be twice the desired operating frequency, because an internal flip-flop is used to produce a precise 50% duty cycle signal to the drivers.

TTL_{OUT}

When multiple PWS745-1 drivers must be synchronized to minimize beat frequencies in the output, a single driver is used to synchronize with the remaining drivers. The TTL_{OUT} pin is used as the synchronizing signal from the master controller and is connected to the TTL_{IN} of the slave drivers. A standard open collector output is provided, therefore a

330Ω to 3.3kΩ pull-up resistor will be necessary, depending on the stray capacitance on the synchronizing line. A maximum of 8 PWS745-1s can be connected without the use of an external TTL buffer.

ENABLE

An ENABLE pin is provided so that the DRIVE and $\overline{\text{DRIVE}}$ pins can be shut down to the low state within one cycle to minimize power use if desired. A TTL low applied to the pin will shut down the driver and a TTL high will enable the driver. The TTL_{OUT} will still have the 1.2MHz signal so that a master driver can be disabled without shutting down the remaining synchronized drivers. The pin can be left open for normal operation.

DRIVE, $\overline{\text{DRIVE}}$

These pins are normally connected directly to the adjacent GATE pin and are used to drive the gates of the internally packaged MOSFETs. If desired, these pins may be used instead to drive the gates of external FETs, such as those used in the PWS750 series of power components. It is important to minimize the capacitance on these nodes to insure the rapid charging of the MOSFET gates.

GATE, $\overline{\text{GATE}}$

These pins are normally connected directly to the adjacent DRIVE pins, which are internally connected to the gates of the MOSFETs.

T, $\overline{\text{T}}$

The T and $\overline{\text{T}}$ pins are the complementary transformer drive connections. The signals on these pins are 600kHz complementary square waves with twice the amplitude of the input voltage. These lines connect MOSFET switches to the isolation transformers through the T_O and $\overline{\text{T}}_O$ pins. Without proper printed circuit board layout techniques, these lines could generate interference to analog circuits. Refer to the section on layout techniques.

T_O, $\overline{\text{T}}_O$

These pins are the primary terminals of the transformer and are connected to the T and $\overline{\text{T}}$ pins of the PWS745-1.

V_D

The center tap of the primary of the transformer is tied directly to the supply. A 0.3μF bypass capacitor must be located as close to this pin as possible.

AC

The output of the isolation transformer which is connected to the AC inputs on the PWS740-3 or PWS750-3 diode bridge.

PC BOARD LAYOUT CONSIDERATIONS

Multilayer printed circuit boards are recommended for PWS745 systems. Two-layer boards are certainly possible

with satisfactory operation; however, three layers provide greater density and better control of interference from the power switching lines. Should a four-layer board be required for other circuitry, the use of separate layers for ground and power planes, a layer for switching signals and a layer for analog signals would allow the most straightforward layout of the PWS745 system. Critical consideration should go to minimizing electromagnetic radiation from the power switching lines T-T_O and $\overline{\text{T}}_O$. The dynamic component of the current is supplied by the bypass capacitor on the V_D pin of the transformer. The high frequency AC current flows through the transformer, T_O, returning in the T pin, passing through the MOSFET and exiting through the COM pin back to the bypass capacitor. This current path defines a magnetic loop which transmits a magnetic field. The magnetic field lines reinforce at the center of the loop, while the field lines from opposite points of the loop oppose each other outside the loop. Cancellation of the magnetic radiation occurs when the loop is collapsed to two tightly spaced parallel line segments, each carrying the same current in the opposite direction. All of the current in the ground or power plane will flow directly under the T-T_O traces because this is the path of least inductance or impedance. Another potential problem with the T-T_O lines is electric field radiation. Here, the power plane is effective in terminating most of the field lines because of its proximity. Additional shielding can be obtained by running ground trace(s) along the T-T_O lines, facilitating a minimum loop area for the transformer's center-tap bypass capacitor.

The connection between the outputs of the transformer and the diode bridge should be kept as short as possible. Unnecessary stray capacitance on these lines could cause resonant peaking to occur, resulting in a slight increase in output voltage.

EXTERNAL FILTER COMPONENTS

Filter components are necessary to reduce the input ripple current and output voltage noise. Without any input filtering, the sawtooth currents of the switching power lines T-T_O and $\overline{\text{T}}_O$ would flow in the supply line. Since this AC current can be as great as 1A peak, voltage interference with other components using this supply line would likely occur. Use of a pi-filter can reduce the input ripple current to about 1mA peak. Recommended values are a 20μH inductor prior to the connection of the supply to the power plane. A 10μF tantalum capacitor with a 0.33μF ceramic capacitor is adequate for the input bypassing. The inductor must be rated for at least 2A or a DC resistance of 0.1Ω. An example of a low-cost inductor is part number 51591 from Pulse Engineering. Output voltage filtering is achieved with a 0.33μF capacitor connecting each V_{OUT} pin of the diode bridge to ground. Short leads and close placement of the capacitors to the bridge provide optimum high frequency bypassing. Using correct bypassing techniques, 600kHz ripple of less than 5mVp-p is achievable. High frequency noise bursts coinciding with the switch times are approximately 20mVp-p. Inductance of 20μH in series with the output loads will significantly reduce the noise seen by the loads.

5V OPERATION

With 5V operation, the transformer winding ratio is 3-to-1, generating much greater currents in the primary. Therefore, four channels are the maximum that can be powered directly by the PWS745-1.

OUTPUT CURRENT RATING

The PWS745-1 driver contains “soft start” driver circuitry to protect the driver MOSFETs and eliminate high in-rush currents during turn-on. Impedance limiting by the isolation transformers provides short circuit protection on the secondary side and limits the primary side current to a safe value.

The total current which can be drawn from each isolation channel at rated voltage is a function of total power being drawn from both V+ and V- outputs. For example, if one output is not used, then maximum current can be drawn from the other output. In all cases, the maximum total current that can be drawn from any individual channel is:

$$|I_{L+}| + |I_{L-}| < 60\text{mA}$$

It should be noted that many analog circuit functions do not simultaneously draw full rated current from both the positive and negative supplies. Thus the PWS745 system can power more circuits per channel than is first apparent. For example, if a circuit draws 10mA from the positive supply and 3mA from the negative supply, the PWS745 could power (60/13), or about four devices per channel.

HIGH VOLTAGE TESTING

Burr Brown Corporation has adopted a partial discharge test criterion that conforms to the German VDE0884 optocoupler standard. This method requires that less than 5pc partial discharge crosses the isolation barrier with 1200Vrms 60Hz applied. This criterion confirms transient overvoltage (1.6 x 750Vrms) protection without damage to the PWS745-2 or PWS745-4. Life test results verify the absence of high voltage breakdown under continuous rated voltage and maximum temperature. The minimum AC voltage that initiates partial discharge above 5pc is defined as the “inception voltage.” Decreasing the barrier voltage to a lower level is required before partial discharge ceases and is known as “extinction voltage.” We have developed a package insulation system to yield an inception voltage greater than 1200Vrms so that transient voltages below this level will not damage the isolation barrier. The extinction voltage is above 750Vrms so that even overvoltage induced partial discharge will cease once the barrier is reduced to the rated value. Previous high voltage test methods relied on applying a large enough overvoltage (above rated) to break down marginal units, but not so high as to permanently damage good ones. Our partial discharge testing gives us more confidence in barrier reliability than breakdown criteria.

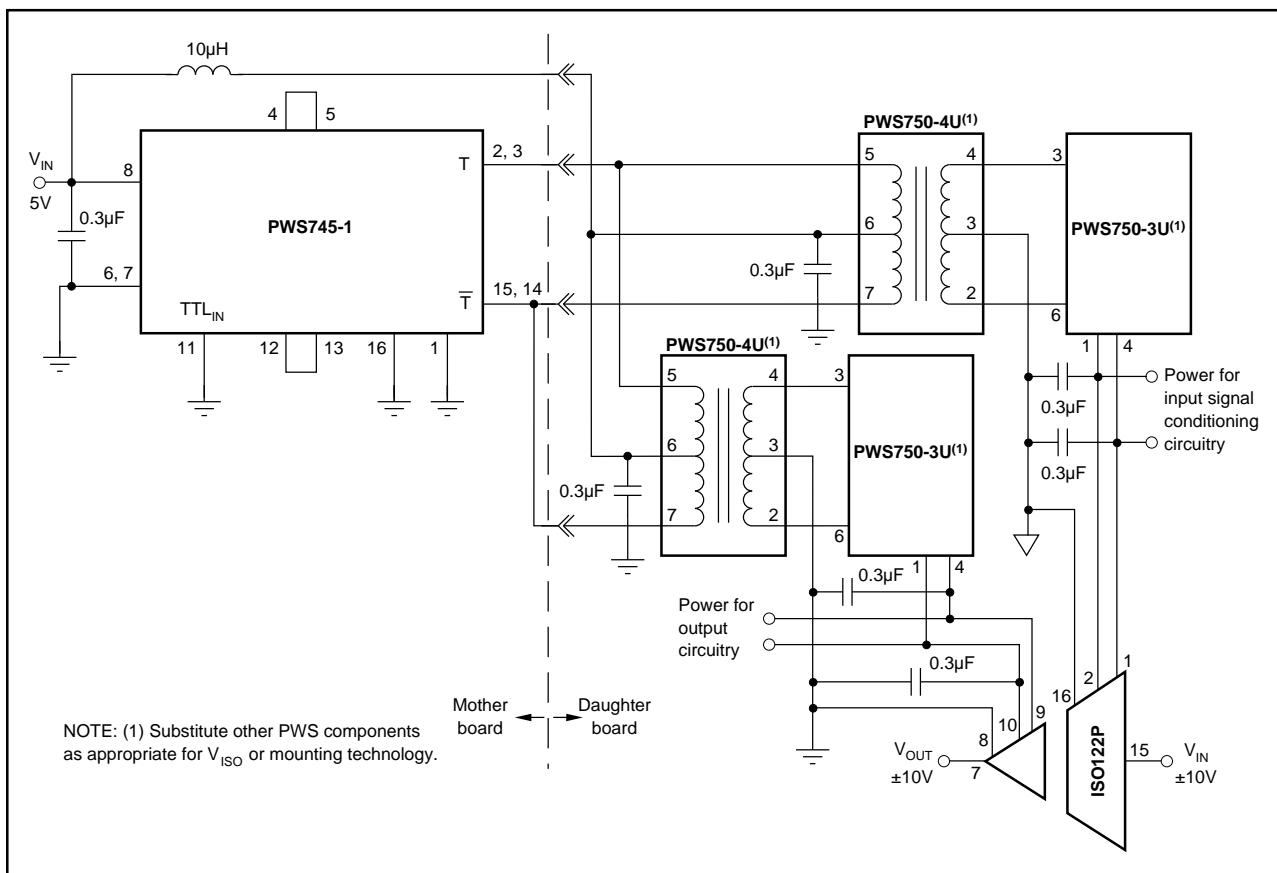

FIGURE 2. Complete ±10V Signal Acquisition System Operating from a Single 5V Supply.

APPLICATIONS

The PWS745 components form part of a versatile collection of isolation power supply components from Burr-Brown. Figures 2, 3, and 4 illustrate only a few of the many possible combinations.

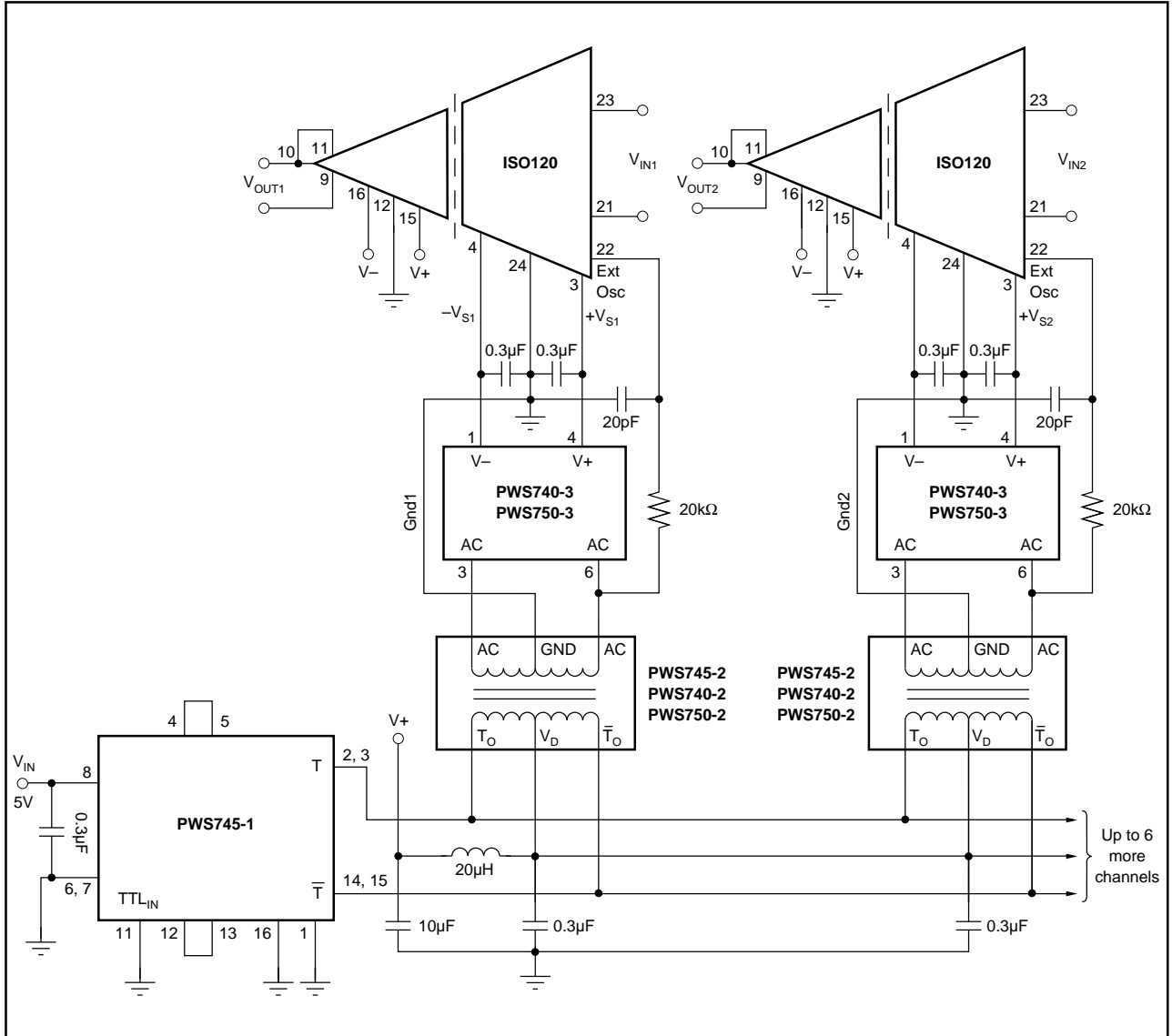

FIGURE 3. Synchronized-Multichannel Isolation System.

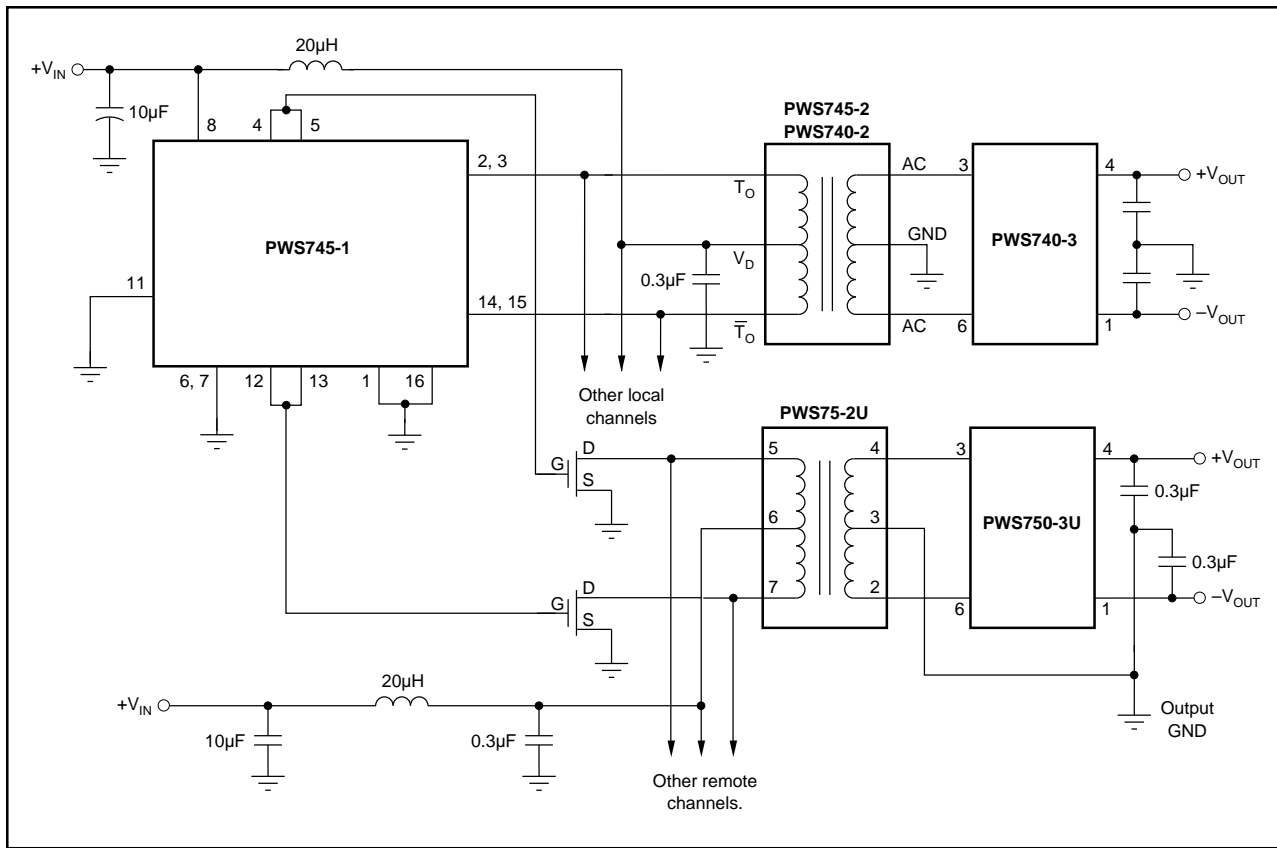

FIGURE 4. Remote and Local Operation of Isolated Power Channels.

Copyright © Each Manufacturing Company.

All Datasheets cannot be modified without permission.

This datasheet has been download from :

www.AllDataSheet.com

100% Free DataSheet Search Site.

Free Download.

No Register.

Fast Search System.

www.AllDataSheet.com